

# HA17524 Series

## Switching Regulator Controller

### FEATURES

- Pulse Width Modulation (PWM)
- Wide Oscillation Frequency Range . . . . . 450kHz (typ)
- Low Quiescent Current . . . . . 5mA typ
- Good Line Regulation (0.2% typ) and Load Regulation (0.4% typ)
- Provides independent output stage of 2 channels. Wide external circuit application including single end method and push-pull method.
- Reference Power Source Output Stage and Switching Output Stage include current limiting protection circuit.
- Compatible with SG3524

### BLOCK DIAGRAM

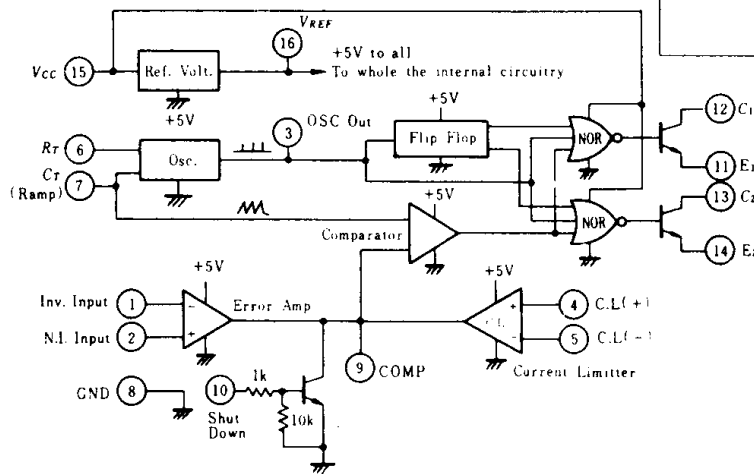

### ABSOLUTE MAXIMUM RATINGS:

(Unless otherwise specified,  $T_a = +25^\circ\text{C}$ )

Item	Symbol	Rating	Unit	Note No
Supply Voltage	$V_{CC}$	40	V	1,2
Collector Output Current	$I_c$	100	mA	
Reference Output Current	$I_{REF}$	50	mA	
Current through $C_r$ Terminal	$I_{Cr}$	5	mA	
Continuous Total Power Dissipation	$P_T$	600	mW	3
Operating Free-Air Temperature Range	$T_{op}$	-20 to +75	$^\circ\text{C}$	
Storage Temperature Range	Cerdip	-65 to +150	$^\circ\text{C}$	
	Plastic	-55 to +125		

The absolute maximum ratings are limiting values, to be applied individually, beyond which the device may be permanently damaged. Functional operation under any of these conditions is not guaranteed. Exposing a circuit to its absolute maximum rating for extended periods of time may affect the device's reliability.

- Note
1. With respect to network ground terminal.
  2. The reference voltage can be given by connecting the  $V_{CC}$  and 5V reference output pins both to the Supply Voltage. In this configuration,  $V_{CC} = 6V_{max}$ .
  3. HA17524P: Value at  $T_a \leq 52.7^\circ\text{C}$ . In case of more than it, 8.3mW/ $^\circ\text{C}$  derating shall be performed.  
HA17524G: Value at  $T_a \leq 71^\circ\text{C}$ . In case of more than it, 7.6mW/ $^\circ\text{C}$  derating shall be performed.

HA17524G

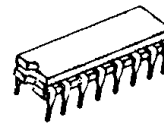

(DG-16)

HA17524P

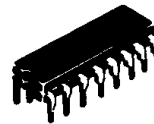

(DP-16)

### PIN ARRANGEMENT

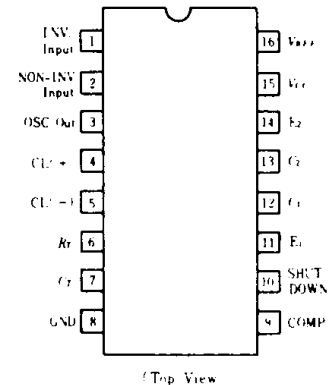

### Dissipation Derating Table

Package	Power Rating	Derating Factor	Above $T_a$
P	600mW	8.3mW/ $^\circ\text{C}$	52.7 $^\circ\text{C}$
G	600mW	7.6mW/ $^\circ\text{C}$	71 $^\circ\text{C}$



## ■ ELECTRICAL CHARACTERISTICS ( $V_{CC} = 20V$ , $f = 20kHz$ , $T_a = 25^\circ C$ )

Item		Symbol	Test Conditions	min	typ	max	Unit
Regulator	Output Voltage	$V_{REF}$		4.6	5.0	5.4	V
	Input Regulation	$\delta V_{O.LIN}$	$V_{CC} = 8$ to $40V$	—	10	30	mV
	Ripple Rejection	$R_{RRJ}$	$f = 120Hz$	—	66	—	dB
	Output Regulation	$\delta V_{O.LOAD}$	$I_{OUT} = 0$ to $20mA$	—	20	50	mV
	Output Voltage Change With Output Temperature	$\delta V_{O}/\delta T_a$	$T_a = 0$ to $+70^\circ C$	—	0.3	1.0	%
			$T_a = -20$ to $+75^\circ C$	—	0.4	1.36	%
Short-Circuit* Output Current	$I_{OS}$	$V_{REF} = 0$	—	100	—	mA	
Error Amplifier	Input Offset Voltage	$V_{IO}$	$V_{IC} = 2.5V$	—	2	10	mV
	Input Bias Current	$I_I$	$V_{IC} = 2.5V$	—	2	10	$\mu A$
	Open-Loop Voltage Gain	$A_{VD}$		—	60	—	dB
	Common-Mode Input Voltage Range	$V_{CM}$	$T_a = 25^\circ C$	1.8 to 3.4	—	—	V
	Common-Mode Rejection Ratio	$CMR$		—	70	—	dB
	Unity-Gain Bandwidth	$BW$		—	3	—	MHz
	Output Swing	$V_{OPP}$		0.5	—	3.8	V
Oscillator	OSC. Frequency	$f$	$C_T = 0.001\mu F$ , $R_T = 2k\Omega$	—	450	—	kHz
	Standard Deviation of Frequency	$\Delta f$	$V_{CC} = 8$ to $40V$ , $R_T = 1.8$ to $100k\Omega$ $C = Const$	—	5	—	%
	Frequency Change with Temperature	$\delta f/\delta T_a$	$V_{CC} = 8$ to $40V$	—	—	1.0	%
			$T_a = 0$ to $+70^\circ C$	—	5.0	10	%
			$T_a = -20$ to $+75^\circ C$	—	5.0	13.6	%
	Output Amplitude	$V_{I.P.P.}$	$3I_{Pin}$	—	3.5	—	V
Output Pulse Width	$T_P$	$C_T = 0.01\mu F$ , $3I_{Pin}$	—	0.5	—	$\mu s$	
Comparator	Maximum Duty Cycle	$D_{MAX}$		45	—	—	%
	Input Threshold Voltage	$V_{IS0}$	duty = 0	—	1.0	—	V
		$V_{ISMAX}$	duty = max	—	3.5	—	V
	Input Bias Current	$I_I$		—	-1	—	$\mu A$
Current Limiter	Input Voltage Range	$V_{IS}$		-0.7 to +1.0	—	—	V
	Sense Voltage	$V_S$	$V(Pin9) = 2V$ , $T_a = 25^\circ C$ $V(Pin2) - V(Pin1) \approx 50mV$	180	200	220	mV
	Sense Voltage Change with Temperature	$\delta V_S/\delta T_a$	$T_a = -20$ to $+75^\circ C$	—	0.2	—	mV/ $^\circ C$
Output	Collector-Emitter Breakdown Voltage	$V_{CE}$		40	—	—	V
	Collector Off-State Current	$I_{LMAX}$	$V_{CE} = 40V$	—	0.01	50	$\mu A$
	Collector-Emitter Saturation Voltage	$V_{CE(SAT)}$	$I_C = 20mA$	—	1	2	V
	Emitter Output Voltage	$V_E$	$V_{CC} = 20V$ , $I_E = -250\mu A$	17	18	—	V
	Turn-off Voltage Rise Time	$t_r$	$R_C = 2k\Omega$	—	0.2	—	$\mu s$
	Turn-on Voltage Fall Time	$t_f$		—	0.1	—	$\mu s$
Total Device	Standby Current	$I_{ST}$	$V_{CC} = 40V$ , $V_2 = 2V$ , Pins 1,4,7,8,9,11,14, grounded All other pins open.	—	5.0	10	mA

Note) \*Duration of the short-circuit should not exceed one second.

APPLICATION NOTE

- Principal in HA17524 Operation

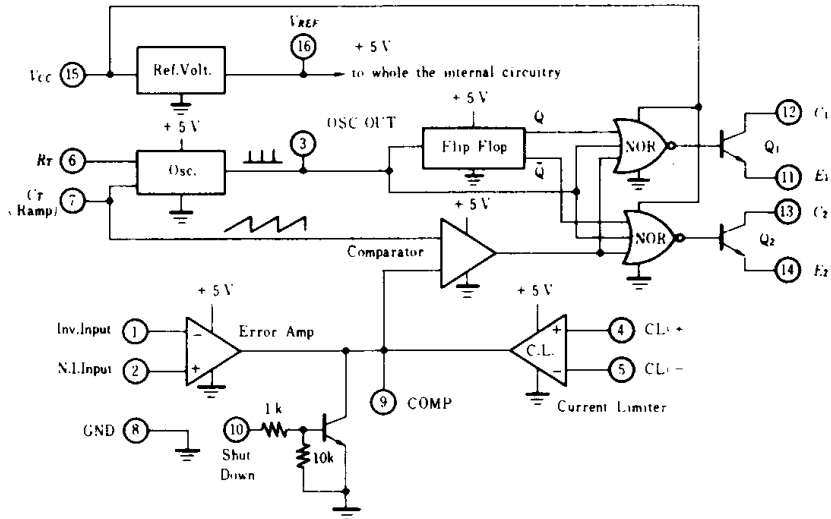

Fig. 1 HA17524 Block Diagram

HA17524 is a switching regulator circuit using Pulsewidth Modulating Method (P.W.M) constructed by the block shown in Fig. 1.

Timing resistance, R<sub>T</sub> and timing capacitance, C<sub>T</sub> control the oscillating frequency and the C<sub>T</sub> is charged by a constant current generated by the R<sub>T</sub>. Lump signals (saw-teeth wave) at C<sub>T</sub> terminal generated in this oscillator is available for reference input signal to comparators which control the pulse-width.

Commonly connected outputs from the error-amplifier, the current limiter and the shut-down circuit is provided to the comparator, which enable to break output stage by input signal in any one of those circuits.

Blocks Description

Oscillator; The oscillating frequency *f* is calculated from the following equations. Fig. 3 shows one example.

$$f \approx 1.15 / (R_T \cdot C_T)$$

$$R_T = 1.8k\Omega \text{ to } 100k\Omega$$

$$C_T = 0.001 \text{ to } 0.1\mu F$$

$$f = 140\text{Hz to } 500\text{kHz}$$

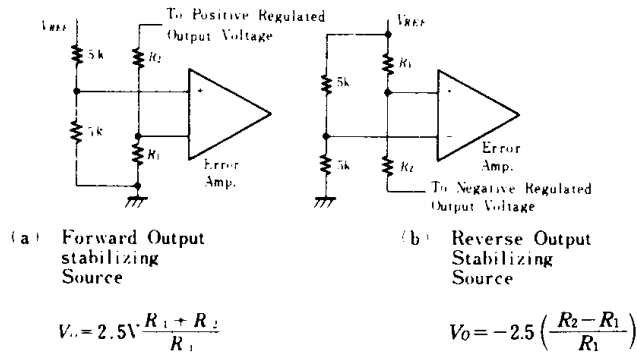

Fig. 2 Biasing in Error-Amplifier

As shown in Fig. 2 the reference voltage connects to non-inverted on inverted input terminal of error-amplifier via resistance divider.

The output voltage from the error-amplifier is compared with the lump signal of the Timing Capacitance C<sub>T</sub>, as shown in Fig. 1 and comparator can provide a signal with modulated pulse width.

This signal, then, control output transistors Q<sub>1</sub> and Q<sub>2</sub>, making an open loop to stabilize output voltage.

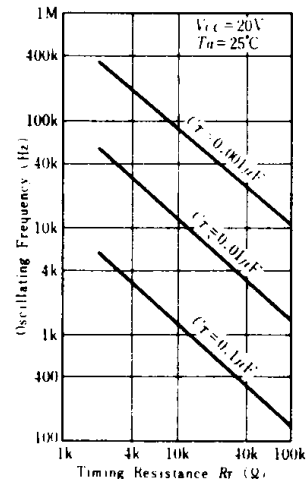

Fig. 3 Oscillating Frequency vs Timing Resistance



Then the lump wave shown in Fig. 4 is available at pin 7, C<sub>T</sub> Terminal since the C<sub>T</sub> is charged by the constant current I generated by the R<sub>T</sub>.

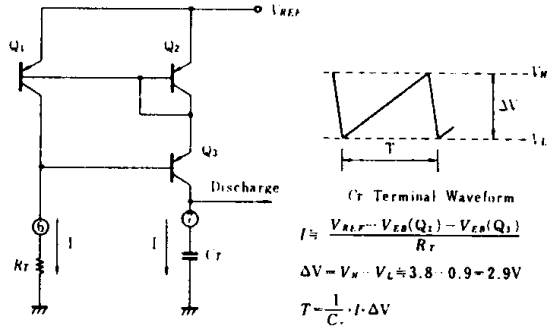

Fig. 4 Oscillating Circuit and C<sub>T</sub> Terminal Waveform

The output pulse signal at oscillator is used as elements in Flip-flop circuit and (a synchronous signal of clock-pulse) switching. The pulse-width which can be controlled by the timing capacitor C<sub>T</sub> as shown in Fig. 5 provides function to gain a dead time of output.

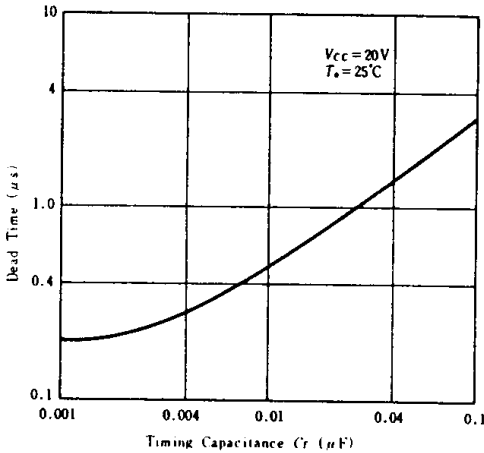

Fig. 5 Dead Time vs Timing Capacitance

**Reference Voltage:** The regulator (reference voltage: V<sub>REF</sub> = 5 ± 0.4V) is built in Integrated Circuit. It can be used as reference power supply of error amplifier which determines Output Voltage Output (V<sub>OUT</sub>). And also, it is connected as bias source of another circuit in IC.

**Error Amplifier:** Biasing in error amplifier is shown in the Fig. 2. Input Applied Voltage is required to be set within the range of common-mode Input Voltage (1.8V to 3.4V). If resistor and capacitor are inserted between phase compensation terminal (Pin 9) and GND in series, phase compensation is available.

**Current Limiter:** Threshold Voltage (V<sub>S</sub>) of sense amplifier for current limiter is calculated as follows;

$$V_S = V_{BE}(Q_1) + I_1 R_2 - V_{BE}(Q_2)$$

$$= I_1 R_2$$

$$= 200mV \text{ typ.}$$

At Current limiter Sense Amp shown in the Fig. 6, when V<sub>+</sub> - V<sub>-</sub> ≥ 200mV, Q<sub>1</sub> turns "ON", Phase compensation terminal becomes low level and Output Switching element is cut off.

Fig. 7 shows an example of detecting current limit. As the range of Input Voltage is -0.7V to +1.0V; detection output of current limit is provided from GND Line.

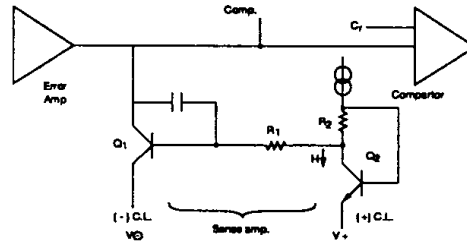
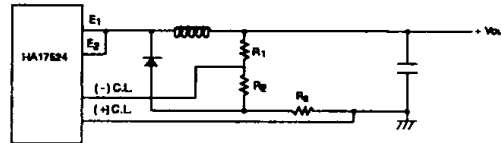

Fig. 7 An Example of detecting current limit



$$I_{O,max} = \frac{1}{R_S} \left( V_{sense} + \frac{V_n R_2}{R_1 + R_2} \right)$$

$$I_{O,S} = \frac{V_{sense}}{R_S}$$

$$V_{sense} = 200mV$$

● Operating waveform at every part

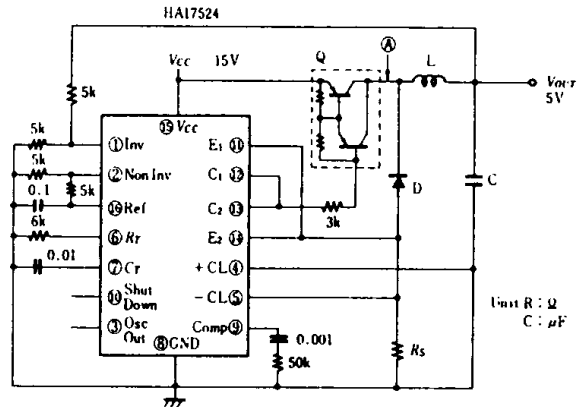

Fig. 8 Breakdown Voltage types Chopper Switching Regulator

Fig. 9 shows operating waveform at every part, when the circuit configuration of breakdown voltage type chopper switching regulator (shown in the Fig. 8) is used. Operating Conditions are as follows,  $f = 20\text{kHz}$ ,  $V_{OUT} = 5\text{V}$ . At output section, two channels are connected in parallel. Operating waveform inside IC is shown at the same time.

**CAUTIONS**

Compared with the conventional series regulator, switching regulator generates high frequency noise by switching current quickly. To reduce noise, the following shall be followed.

- 1) As a general rule, insert line filter in order to reduce noise at the side of Input.
- 2) To reduce noise at the side of output,
  - (a) Output wiring should be twisted.
  - (b) Power Source and output wiring should not be bundled.
  - (c) Capacitor should be inserted at the side of load.
  - (d) Power frame should be grounded.
- 3) When grounding frame, output (0V) and Shielding wire, Only one of them should be grounded. Impedance must be as low as possible. And also, Power frame should be grounded. In case of choosing external parts-external switching transistor, diode, coil and etc. -, it is necessary to consider their capacitance and characteristics.

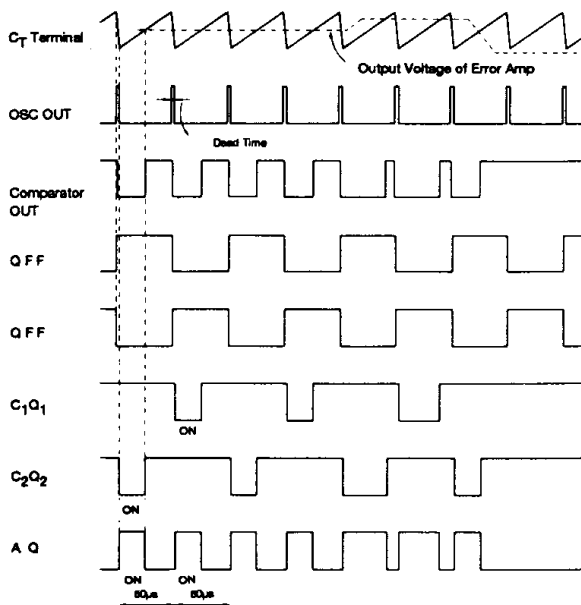

Fig. 9 Operating Timing Chart of each part

**Circuit Applications**

Simple polarity switching regulator: Fig. 10 shows the circuit configuration of HA17524 polarity switching regulator which has small current capacitance ( $V_{OUT} = -5\text{V}$ ).

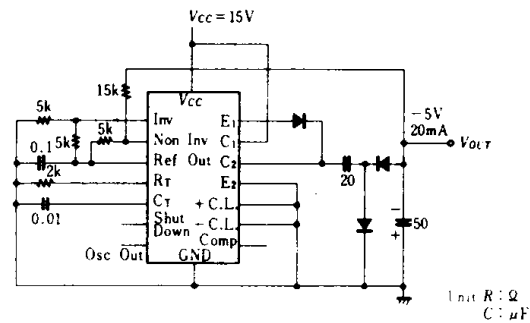

Fig. 10 Simple Type Polarity Conversion

Tracking switching regulator: The circuit configuration of tracking regulator which uses transformer is shown in the Fig. 11 ( $V_{OUT} = \pm 5\text{V}$ ).

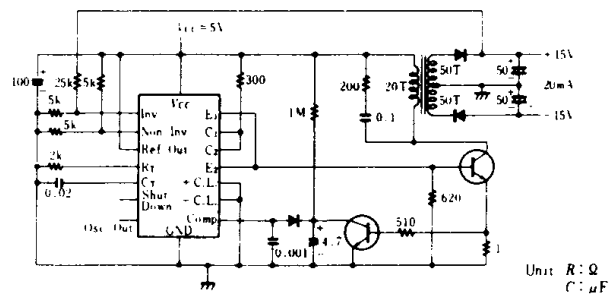

Fig. 11 Tracking Switching Regulator

Push-pull switching regulator: Fig. 12 shows the circuit configuration of Push-pull switching regulator which uses transformer. This system is suited for large power. Output transistors inside HA17524 can drive external switching transistors respectively.

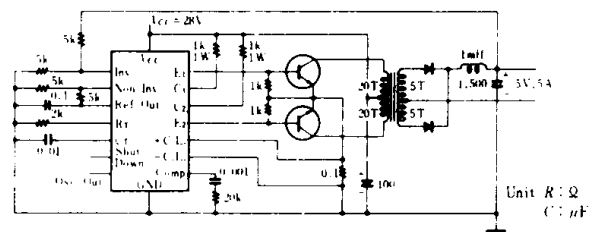
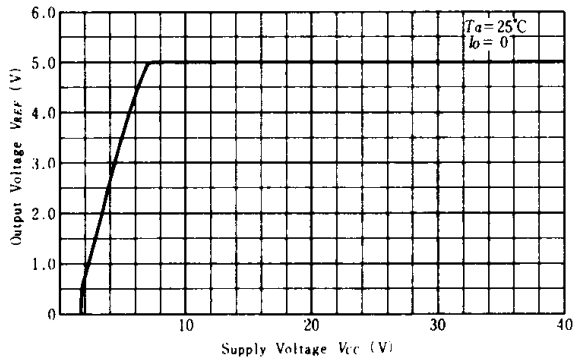

Fig. 12 Push-pull Switching Regulator



**OUTPUT VOLTAGE VS. SUPPLY VOLTAGE**



**OUTPUT SATURATION VOLTAGE VS. COLLECTOR CURRENT**

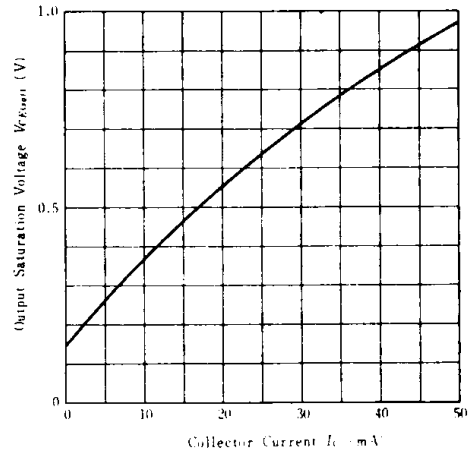

**OSCILLATING FREQUENCY VS. TIMING RESISTANCE**

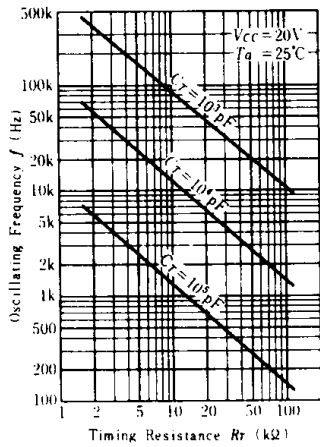

**OUTPUT VOLTAGE VS. FREE AIR TEMPERATURE**

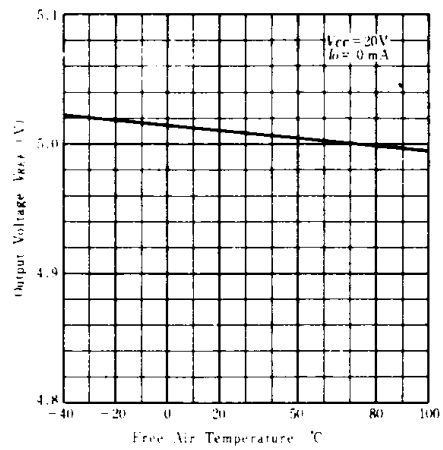

**DEAD TIME VS. TIMING CAPACITANCE**

