

SYNC separator IC with AFC

BA7062F

The BA7062F separates the synchronization signals from a video signal and outputs the horizontal and vertical synchronization signals (H_D and V_D), and the composite synchronization signal (Sync-out). The H_D and V_D pulse widths are different.

●Applications
TVs and VCRs

●Features

- 1) Built-in AFC circuit.
- 2) Low power dissipation (approx. 21mW).
- 3) Low external parts count.
- 4) SOP 8-pin package.
- 5) Horizontal free-run frequency does not require adjustment.

●Absolute maximum ratings (Ta = 25°C)

Parameter	Symbol	Limits	Unit
Power supply voltage	V _{CC Max.}	8.0	V
Power dissipation	P _d	350*	mW
Operating temperature	T _{opr}	- 20 ~ + 75	°C
Storage temperature	T _{stg}	- 55 ~ + 125	°C

* When mounted on a 50mm × 50mm PCB, reduced by 3.5mW for each increase in Ta of 1°C over 25°C.

●Recommended operating conditions (Ta = 25°C)

Parameter	Symbol	Min.	Typ.	Max.	Unit
Operating power supply voltage	V _{CC}	4.5	—	5.5	V

●Block diagram

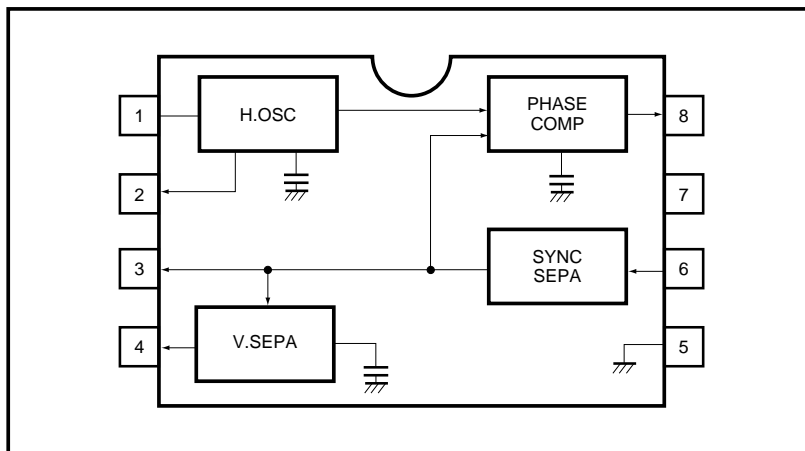

● Pin descriptions

Pin No.	Function
1	Horizontal oscillator resistor
2	Hb output
3	SYNC output (open collector)
4	Vb output
5	GND
6	Video input
7	Power supply
8	Phase comparator output

● Input / output circuits

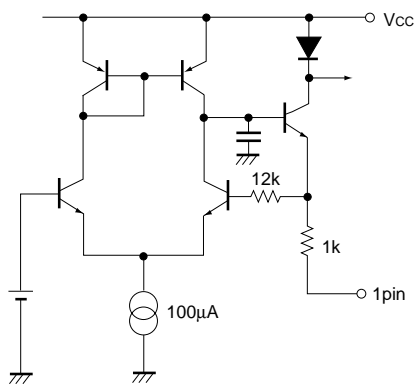

Fig. 1

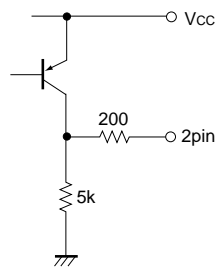

Fig. 2

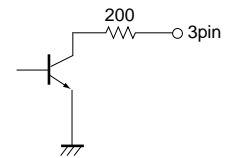

Fig. 3

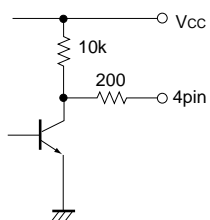

Fig. 4

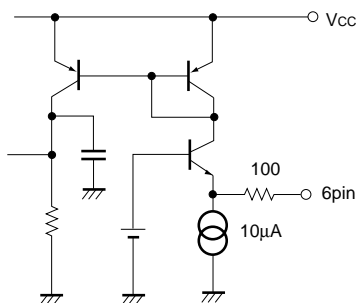

Fig. 5

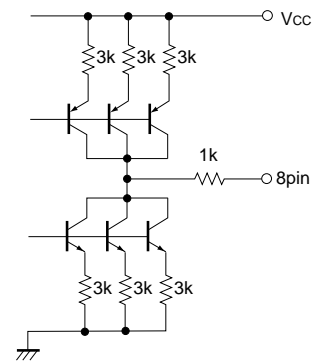

Fig. 6

●Electrical characteristics (unless otherwise noted, Ta = 25°C and Vcc = 5V)

Parameter	Symbol	Min.	Typ.	Max.	Unit	Conditions
Quiescent current	I _Q	2.0	4.1	6.2	mA	Pin 3 open
Minimum SYNC separation level	V _{syn-Min.}	—	0.08	0.15	V _{P-P}	Pin 6 terminated with 75Ω resistor
Pulse voltage, Low	V _{P-L}	—	0.1	0.3	V	2, 4 pin
Pulse voltage, High	V _{P-H}	4.7	4.9	—	V	2, 4 pin
(Horizontal) free-running frequency	f _{H-O}	13.9	15.7	17.5	kHz	No input signal, I ₁ = open
Capture range	Δf _{CAP}	± 2.1	± 2.9	—	kHz	—
Lock-in phase	T _{HPH}	- 1.0	0	+ 1.0	μs	2pin ↓ - 6pin ↓
H _D pulse width	T _{HD}	10.5	11.5	12.5	μs	2pin ↓ ↑
V _D pulse width	T _{VD}	200	260	320	μs	4pin ↓ ↑

○ Not designed for radiation resistance.

●Measurement circuit

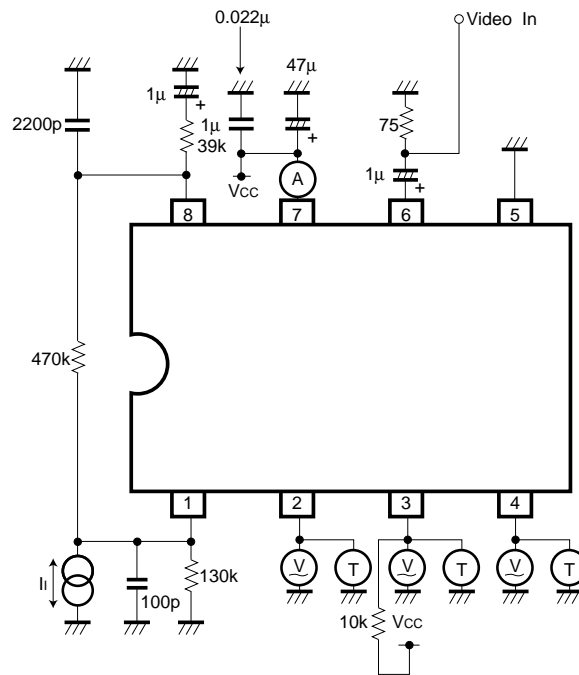

Fig. 7

●Circuit operation

(1) Synchronization separation circuit

Detects the charging current to a externally-connected capacitor, and performs synchronization separation.

(2) Horizontal oscillation circuit

When a video signal is input, it is synchronized with Hsync by the PLL. The horizontal free-running frequency is determined by external resistor R₁.

$$f_{H-O} = \frac{2.05E6}{R_1} \text{ [kHz]}$$

(3) Vertical synchronization separation circuit

When a video signal is input, synchronization signal separation is done over the vertical synchronization pulse interval.

● V_{IN} , H_D , and V_D timing charts

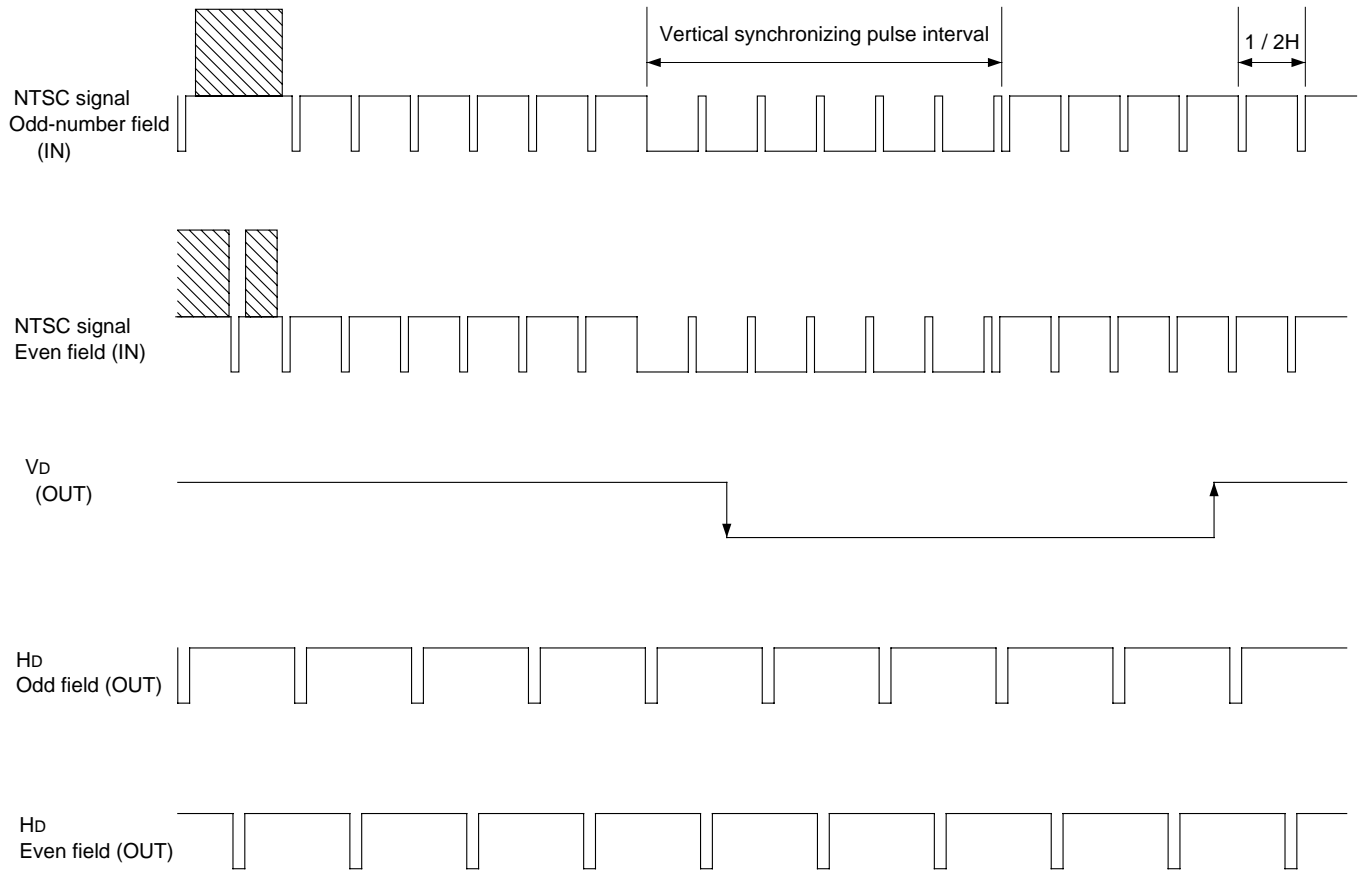
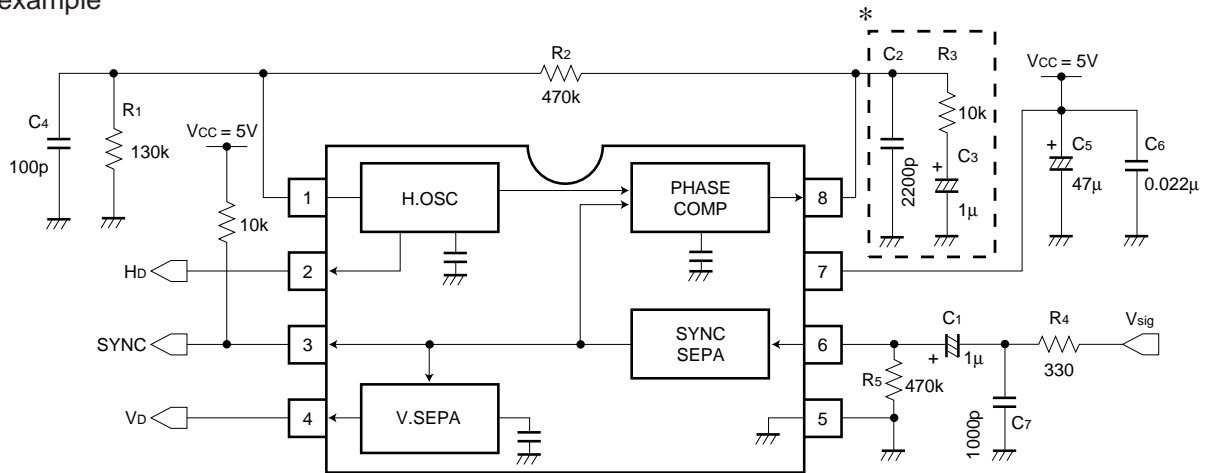

Fig. 8

- (1) The rise and fall positions for V_D are basically the same for both odd and even fields.
- (2) H_D shifts by $1/2H$ during the odd and even field interval.

●Application example



* By configuring the circuit enclosed in the dotted line to that in the diagram on the right, you can decrease the lock-in time and increase the capture range.

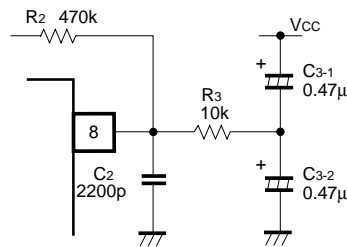

Fig. 9

- When SYNC SEPA output only is used. H_D and V_D unused.

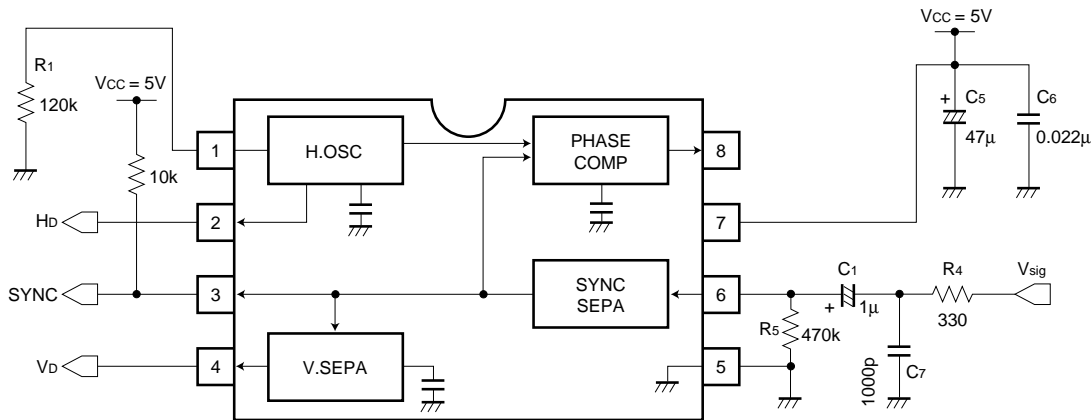

Fig. 10

- (1) Connect pin 1 to GND via a 120kΩ (approx.) resistor. Leave pins 2, 4 and 8 open.
- (2) SYNC output polarity (pin 3) is positive.
- (3) The delay time for rising edge of the SYNC output (pin 3) with respect to the falling edge of Sync for the V_{sig} input signal (pin 6) is 850ns (reference value).
- (4) The delay time for falling edge of the SYNC output (pin 3) with respect to the rising edge of Sync for the V_{sig} input signal (pin 6) is 450ns (reference value).

●Attached components

Resistor R₁ should have a tolerance of ± 2%, and a temperature coefficient of 100ppm or lower.

●Electrical characteristic curves

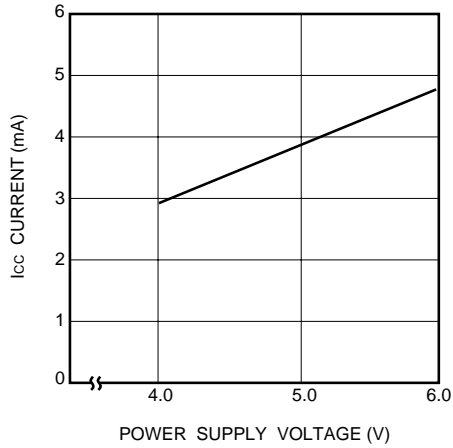

Fig. 11 Quiescent current vs. power supply voltage

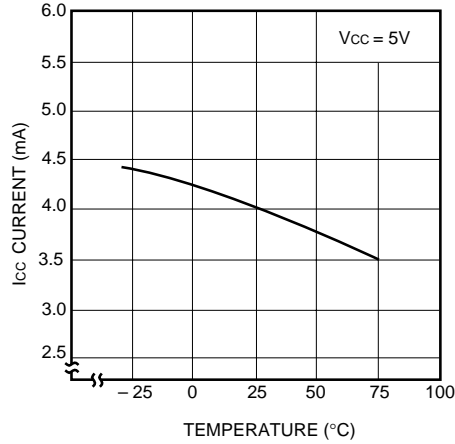

Fig. 12 Quiescent current vs. temperature

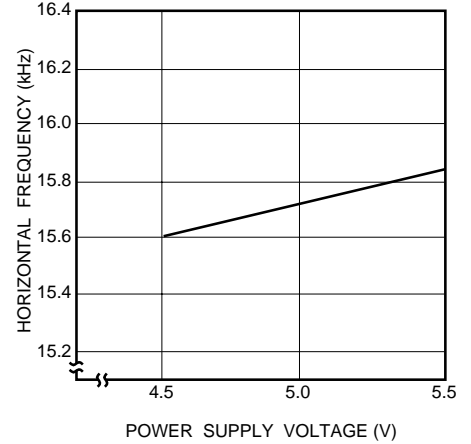

Fig. 13 Horizontal free-running frequency vs. power supply voltage

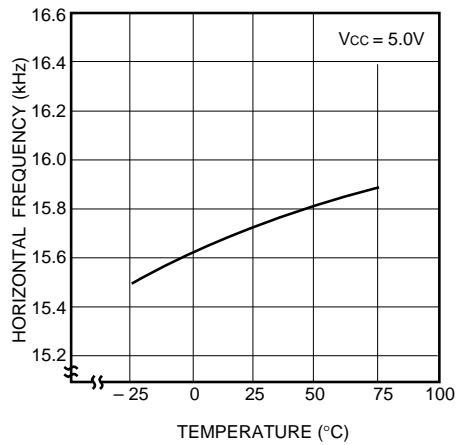

Fig. 14 Horizontal free-running frequency vs. temperature

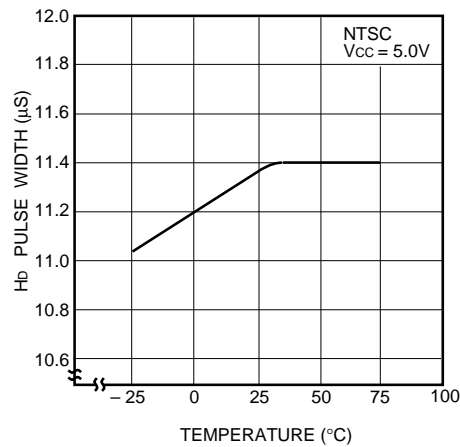

Fig. 15 Hd pulse width vs. temperature

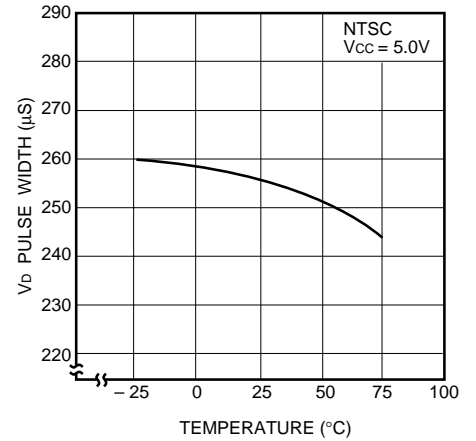

Fig. 16 Vd pulse width vs. temperature

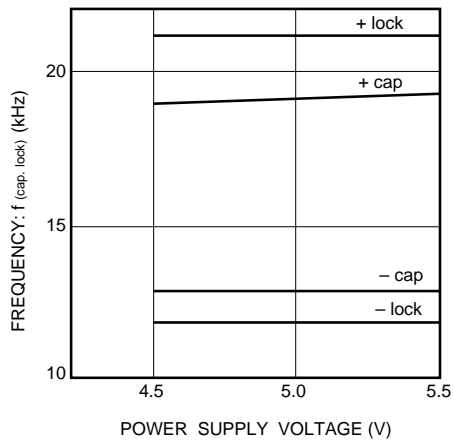

Fig. 17 Capture range / lock range vs. power supply voltage

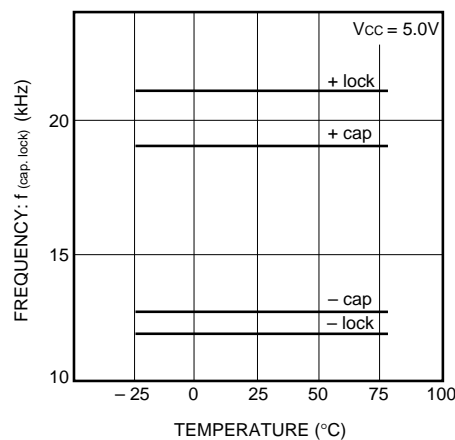

Fig. 18 Capture range / lock range vs. temperature

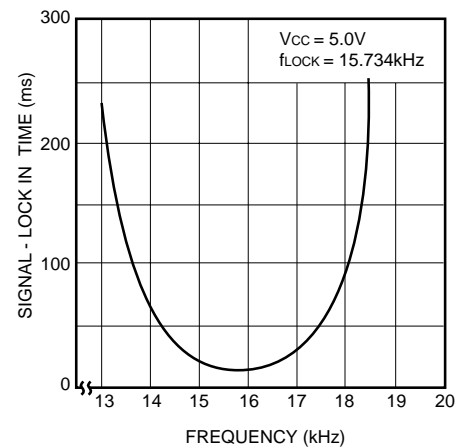

Fig. 19 Time from no signal to pull in

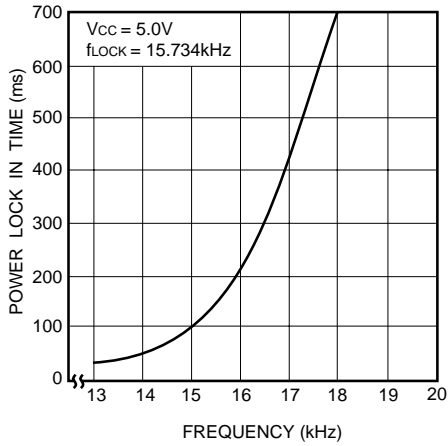

Fig. 20 Time from power on to pull in

● Operation notes

- Make the ground line as thick as possible.
- Keep power supply noise to a minimum.

● External dimensions (Units: mm)

