

## Features

- Self-Powered Hub with Bus Power Controller
- Full Compliance with USB Spec Rev 1.0
- Full Speed USB Host Interface
- Four Downstream Ports
- Downstream Support for Full Speed and Low Speed Transfer Rates
- Continual Monitoring of Port by System Host
- Individual Port Power Control
- USB Connection Status Indicators
- 6 MHz Oscillator with On-Chip PLL

## Description

The AT43311 is a fully compliant USB hub chip with 5 ports, one upstream port and four full/low-speed downstream ports. The AT43311 can be used as a stand alone or can provide a simple and quick method of adding USB ports to an existing device.

As a repeater, the AT43311 provides upstream connectivity between the selected function and the host. Connectivity involves setting up and tearing down connections, handling bus faults, recovering from bus faults and detecting downstream device connections and disconnections.

The AT43311 may also act as a hub controller managing the hub operations and recording the status of the hub, bus transactions, and downstream ports. In this mode, the AT43311 tracks and generates the bus enumeration, provides configuration information to the host, provides individual port status to the host, and controls the port operation based on host commands.

## Pin Configurations

SOIC/DIP/Cerdip

PWR2	1	32	PWR1
PWR3	2	31	DP4
PWR4	3	30	DM4
VCC5	4	29	DP3
VSS	5	28	DM3
OSC1	6	27	GND
OSC2	7	26	DP2
LFT	8	25	DM2
VCCA	9	24	VCC3
OVL4	10	23	DP1
OVL3	11	22	XDM1
OVL2	12	21	DP0
OVL1	13	20	DM0
VREF	14	19	STAT1
GND	15	18	STAT2
STAT4	16	17	STAT3



## USB Hub

## AT43311 Preliminary



## Block Diagram

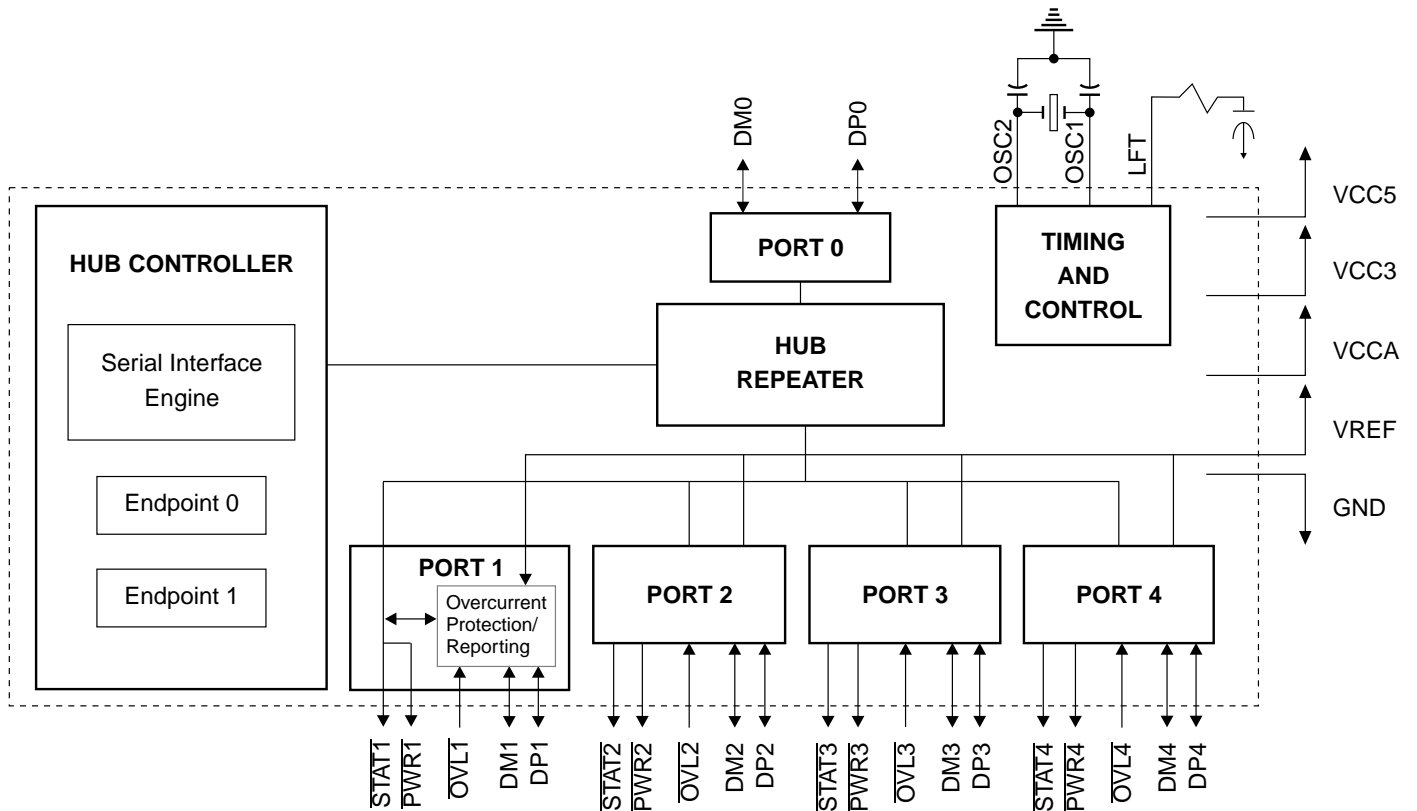

- Note: 1. This document assumes that the reader is familiar with the Universal Serial Bus and therefore only describes the unique features of the AT43311 chip. For detailed information about the USB and its operation, the reader should refer to the Universal Serial Bus Specification Version 1.0, January 19, 1996.

## Pin Description

Pin Description	Pin Type	Description
OSC1	I	Oscillator Input. Input to the inverting 6 MHz oscillator amplifier.
OSC2	O	Oscillator Output. Output of the inverting oscillator amplifier.
LFT	I	PLL Filter. For proper operation of the PLL, this pin should be connected through a 100 $\Omega$ resistor and 10 nF capacitor to ground ( $V_{SS}$ ) in parallel with a 2.2 nF capacitor (see Figure 1–Power Supply Connection).
VREF	I	Reference Voltage. This is an input pin that should be connected to an external voltage source. VREF is used internally as the reference voltage by the overload protection circuit to decide whether there is a problem with a port's power supply.
DP0	B	Upstream Plus USB I/O. This pin should be connected to VCC3 through an external 1.5K $\Omega$ pullup resistor. DP0 and DM0 form the full speed differential signal pin pairs connected to the Host Controller or an upstream Hub.
DM0	B	Upstream Minus USB I/O
DP[1:4]	B	Port Plus USB I/O. These pins should be connected to VSS through external 1.5K $\Omega$ resistors. DP[1:4] and DM[1:4] are the differential signal pin pairs to connect downstream USB devices.
DM[1:4]	B	Port Minus USB I/O. These pins should be connected to VSS through external 15K $\Omega$ resistors. DP[1:4] and DM[1:4] are the differential signal pin pairs to connect downstream USB devices.
$\overline{OVL}$ [1:4]	I	Port Overload. These are the input signals used to indicate to the AT43311 that there is a power supply problem with the port. If $\overline{OVL}$ is asserted, the AT43311 will assert the corresponding $\overline{PWR}$ [1:4] pin and report the status to the USB Host.
$\overline{PWR}$ [1:4]	OD	Power Switch. These are the output signals used to enable or disable the external voltage regulator supplying power to the port. $\overline{PWR}$ [1:4] is de-asserted when a power supply problem is detected at $\overline{OVL}$ [1:4]. For proper operation of $\overline{PWR}$ [1:4], an external pull-up resistor of 10K $\Omega$ to VCC5 is required.
STAT[1:4]	O	Connect Status. These are output pins indicating that a port is properly connected. $\overline{STAT}$ [1:4] is asserted when the port is enabled.
VCC3	V	3.3V Power Supply, used for the USB interface
VCC5	V	5V Power Supply, main power supply for the AT43311
VCCA	V	5V Analog Power Supply
GND	V	Ground

## USB Hub Description

### Hub Repeater

The hub repeater is responsible for port connectivity setup and tear-down. The repeater also supports exception handling such as bus fault detection and recovery, and connect/disconnect detection.

When a SOP token is detected on the upstream port, Port0, the AT43311 determines the speed of the transfer. A USB hub must not propagate a full speed transfer to a low speed port due to the possible misinterpretation of the data. The AT43311 will propagate the packet to all enabled downstream ports.

**Note:** See USB Specification for further detail on bus states

The AT43311 supports downstream data signaling at both 1.5 Mbps and 12 Mbps. Devices attached to the downstream ports are either full speed or low speed depending on which data line (DP or DM) is pulled high. If a port is enumerated as low speed, the output buffers operate at a slew rate between 75 ns and 300 ns. The AT43311 will not propagate any traffic to that port unless it is prefaced with a preamble PID. Low speed data following the preamble PID is propagated to both low and full speed devices. The AT43311 will enable low speed drivers within four full-speed bit times of the last bit of a preamble PID, and will disable the drivers at the end of an EOP. The upstream traffic from any port to the host is propagated by Port0 using the full speed 4-20 ns slew rate drivers.

All ports are independently driven and monitored on the DP and DM pins. The AT43311 detects or generates the 'J', 'K', and SE0 bus signaling states. Each hub port has single-ended and differential receivers on its DP and DM lines. The ports' I/O buffers comply to the voltage levels and drive requirements as specified in the USB Specifications Revision 1.0.

The Hub Repeater implements a frame timer that is timed by the 12 MHz USB clock and is reset every time an SOF token is received from the Host.

### Hub Controller

The hub controller manages and records the operations of the AT43311. During enumeration, the controller sends the host the configuration information. The controller also allows the host to retrieve the status of the downstream ports, and power the downstream ports. The controller applies power to the downstream ports on a per port basis. After configuration, the controller will enable the power to a downstream port upon a SetPortPower command by the host. The controller supports two endpoints and a Control Status register.

### Serial Interface Engine

The Serial Interface Engine (SIE) converts data between the serialized USB format and usable data for the controller and repeater. To carry out these tasks, the SIE is able to detect or generate USB signaling. Once a valid operation is detected, the SIE translates the data depending on the operation.

During a reception, the SIE will use the high speed clock supplied by the PLL to help synchronize and separate the synchronization information from the data. The data must be decoded before the SIE may supply the packet ID to the controller and repeater.

The USB protocol uses Cyclical Redundancy Check (CRC), Non Return to Zero Invert (NRZI) data encoding and bit stuffing to improve the reliability of data transfers. The SIE must decode the NRZI and strip off the stuffed bit to determine the actual data. The CRC information will be used by the SIE to determine if a transmission error has occurred. If an error has occurred, the SIE will correct the data using CRC algorithms.

## Control Status Register

Bit	Function	Value	Description
0	Hub configuration status	0 1	Set to 0 or 1 by a Set_Configuration Request Hub is not currently configured Hub is currently configured
1	Hub remote wakeup status	0 1	Set to 0 or 1 by ClearFeature or SetFeature request Default value is 0 Hub is currently not enabled to request remote wakeup Hub is currently enables to request remote wakeup
2	Endpoint0 STALL status	0 1	Endpoint0 is stalled Endpoint0 is stalled
3	Endpoint1 STALL status	0 1	Endpoint1 is not stalled Endpoint1 is stalled

## Endpoint0

Endpoint0 is the AT43311's default endpoint used for enumeration of the Hub and exchange of configuration information and requests between the Host and the AT43311. Endpoint0 supports control transfers.

Standard USB Device Requests and class-specific Hub Requests are supported through Endpoint0.

The Hub Controller supports the following descriptors through Endpoint0 (Descriptors are described in detail in the Descriptors Section of this document):

- Device Descriptor
- Configuration Descriptor
- Interface Descriptor
- Endpoint Descriptor
- Hub Descriptor

## Endpoint1

Endpoint1 is used by the Hub Controller to send status change information to the Host. Endpoint1 supports interrupt transfers.

The Hub Controller samples the changes at the end of every frame at time marker EOF2 in preparation for a potential data transfer in the subsequent frame. The sampled information is stored as a byte in Status Change Register using a bitmap scheme.

Each bit in the Status Change Register corresponds to one port as shown below.

An IN Token packet from the Host to Endpoint1 indicates a request for port change status. If the Hub has not detected any change on the ports or any changes in the hub itself, then all bits in this register will be 0 and the Hub Controller will return a NAK to requests on Endpoint1. If a change in the port status exists, the Hub Controller will transfer the

whole byte. The Hub Controller will continue to report a status change when polled until that particular change has been removed by a ClearPortFeature request from the Host. No status change will be reported by Endpoint1 until the AT43311 has been enumerated and configured by the Host through Endpoint0.

## Power Management

The AT43311 is designed to be powered from the USB bus. As such, the power consumption for the AT43311 itself is less than 100 mA. However, downstream devices require separate power supplies. The AT43311 monitors and controls each power supply to the individual downstream devices.

Careful design and selection of the power switch is required to meet the USB specification. The USB specifications requires that the voltage drop at the power switch be no more than 100 mV. USB requirements specify that a downstream device may use a maximum of 500 mA. These conditions are best met by using a MOSFET switch with an on resistance of 200 mΩ or less.

As a sample power circuit, consider a P-channel enhancement mode MOSFET. The condition of the port's power is monitored at the output side of the PMOS switch which is connected to the port's  $\overline{OVL}[1:4]$  pin. During an overcurrent condition, the MOSFET switch's internal resistance causes the MOSFET's output voltage to drop at the  $\overline{OVL}[1:4]$  pin. If the MOSFET's output voltage drops to less than the voltage at the VREF voltage reference pin, the AT43311 interprets this drop as an overcurrent condition. The AT43311 does internal filtering to make sure that spurious or switching transients are ignored. If an overcurrent condition exists, the AT43311 removes the power from that port by de-activating the port's  $PWR[1:4]$  pin and reports the condition to the Host.

## Status Change Register

Bit	Function	Value	Meaning
0	Hub status change	0 1	No change in status Change in status detected
1	Port1 status change	0 1	No change in status Change in status detected
2	Port2 status change	0 1	No change in status Change in status detected
3	Port3 status change	0 1	No change in status Change in status detected
4	Port4 status change	0 1	No change in status Change in status detected
5-7	Reserved	0	Default values

**Figure 1. Power Supply Connection**

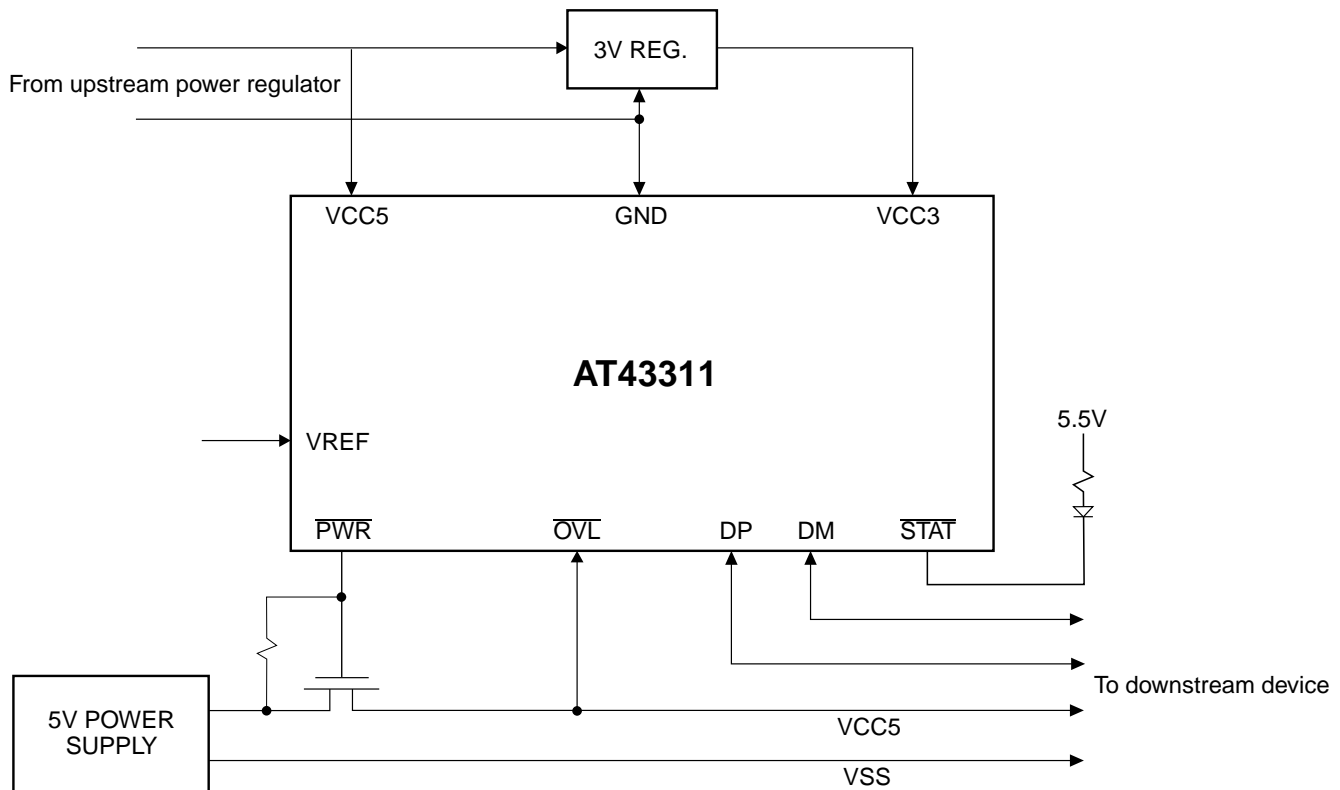

Figure 1 illustrates an example of the power supply connection for a AT43311 port.

Careful consideration must be taken to avoid large ground current surges. There is the possibility that the upstream device and the self powered device will be sourced from different electrical power outlets which share no common ground.

When designing the local power supply for the AT43311 or a self powered device, local 5V power must be isolated. This isolation can be achieved through a transformer or by proper design of the switching power supply. The GND of the Hub or device can then be safely connected to the upstream ports ground line for proper operation of the USB signals.

Even though the devices in a USB network share a common ground (VSS), the two 5V supply voltages of the AT43311 based hub (the upstream's bus power and the local power) must not be connected under any condition.

#### Port [1:4] Power Control

Each port has signals for port power management and for port status feedback ( $\overline{\text{PWR}}[1:4]$ ,  $\overline{\text{OVL}}[1:4]$ , and  $\overline{\text{STAT}}[1:4]$ ). The AT43311 monitors and switches the power to each port individually.

$\overline{\text{PWR}}[1:4]$  are open drain outputs that control the power to the downstream ports. The AT43311 asserts a low value to ports  $\overline{\text{PWR}}[1:4]$  to turn on the power to the port. During

power up, reset, and initialization of the Hub,  $\overline{\text{PWR}}[1:4]$  is in-active.  $\overline{\text{PWR}}[1:4]$  is asserted when the Host instructs the Hub to power the port through the SetPortPower = ON command. Additionally  $\overline{\text{PWR}}[1:4]$  is de-asserted by the Hub when an overcurrent condition is detected at the port.

For proper operation of  $\overline{\text{PWR}}[1:4]$ , an external pull-up resistor to VCC5 is required for  $\overline{\text{PWR}}[1:4]$  pins. To control the power to the port, any switch with a low voltage drop with full power applied is acceptable. The AT43311 is designed for a simple, low cost P-channel MOSFET to use as the switch.

To detect a port overload, the AT43311 compares  $\overline{\text{OVL}}[1:4]$  to a common VREF defined by the designer.

$\overline{\text{OVL}}[1:4]$  should be attached to the power supply of the respective downstream port. If  $\overline{\text{OVL}}[1:4]$  drops below the reference voltage VREF for more than 1 ms, the AT43311 treats the drop in voltage as a fault condition on the port's power supply. Upon this fault condition, the AT43311 sets the port's PORT\_OVER\_CURRENT status bit and the port's C\_PORT\_OVER\_CURRENT bit. The AT43311 will additionally shut off the power to the port by de-activating the port's  $\overline{\text{PWR}}[1:4]$  signal.

The  $\overline{\text{STAT}}[1:4]$  pins are not required by the USB specification.  $\overline{\text{STAT}}[1:4]$  provide feedback to the user whenever a device is properly connected to the port. An LED and series resistor connected to  $\overline{\text{STAT}}[1:4]$  can be used to provide

visual feedback. The default state of  $\overline{\text{STAT}}[1:4]$  is inactive. After a port is enabled AT43311 will assert the port's  $\overline{\text{STAT}}[1:4]$ .

## Oscillator and Phase-Locked-Loop

To reduce EMI and power dissipation in the system, the AT43311 on-chip oscillator is designed to operate with a 6 MHz external crystal. An on-chip PLL generates the high frequency for the clock/data separator of the Serial Interface Engine. In the suspended state, the oscillator circuitry is turned off.

A 6 MHz parallel resonance quartz crystal with a load capacitance of approximately 10 pF is recommended. If the crystal load capacitor is larger, external capacitors added to pins OSC1 and OSC2 are recommended. The values for these capacitors depends on the crystal and the layout of the board, but typically are 33 pF at OSC1 and 47 pF at OSC2. If the crystal used cannot tolerate the drive levels of the oscillator, a series resistor between OSC2 and the crystal pin may be used.

**Figure 2.** Oscillator and PLL Connection

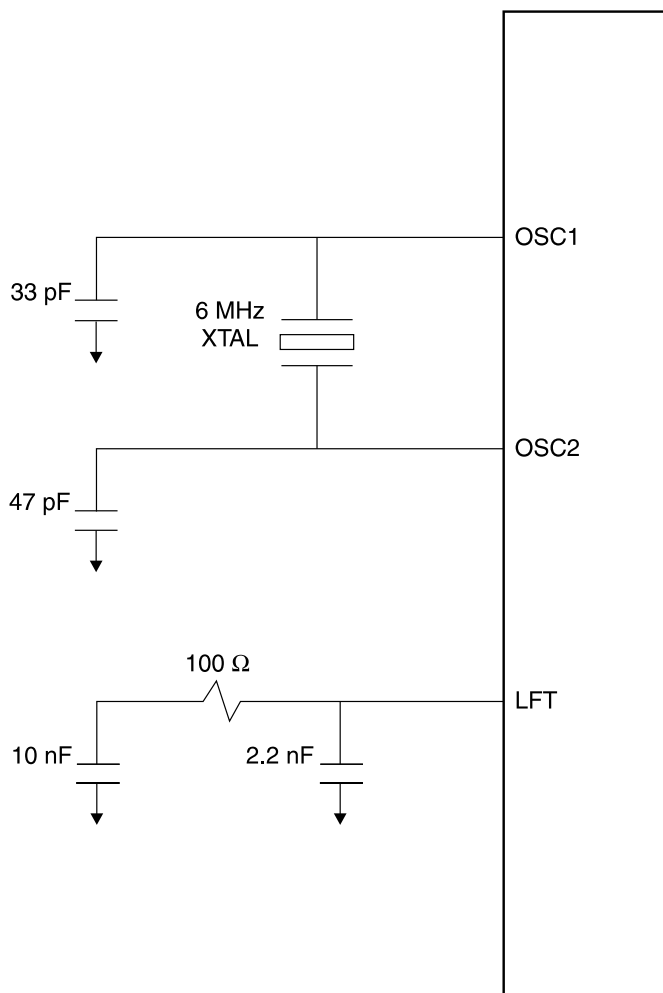

Figure 2 shows how to properly connect the oscillator for the AT43311. Ceramic resonators are not recommended due to the frequency stability required by the USB specification (0.25%).

If desired, the clock can be externally sourced. To clock externally, connect the clock source to the OSC1 pin, while leaving the OSC2 pin floating. The switching level at the OSC1 pin can be as low as 0.47V (see electrical specifications). A CMOS device is required to drive this pin to maintain good noise margins at the low switching level.

For proper operation of the PLL, see Figure 1—Power Supply Connection.

To provide the best operating condition for the AT43311, careful consideration of the power supply connections are recommended. Use short, low impedance connections to all power supply lines: VCC5, VCC3, VCCA, and VSS with 0.1 μF decoupling capacitors of high quality adjacent to the device pins.

## Descriptors

The Hub Controller supports the following standard USB descriptors: Device, Configuration, Interface, and Endpoint Descriptors, as well as the class specific Hub Descriptor. All the required Standard Requests and Hub Class-Specific Requests are supported by the AT43311's Hub Controller.

## Device Descriptor

The Device Descriptor provides general information about the AT43311 Hub.

Offset	Field	Description	Size (bytes)	Value
0	bLength	Define size of descriptor = 18 bytes	1	12H
1	bDescriptorType	Device descriptor type	1	01H
2	bcdUSB	USB Spec. Release Number = Rev 1.0	2	00H 01H
4	bDeviceClass	Class code = HUB_CLASSCODE = 09	1	09H
5	bDeviceSubClass	Subclass code	1	00H
6	bDeviceProtocol	Protocol code	1	00H
7	wMaxPacketSize0	Max. packet size for Endpoint0 = 8-bytes	1	08H
9	idVendor	Vendor ID = Atmel Corporation	2	EBH 03H
10	idProduct	Product ID = AT43311	2	11H 33H
12	bcdDevice	Device release number Example: Rev A0    YY = 01    ZZ = 00 Rev B1    YY = 02    ZZ = 01	2	ZZH YYH
14	iManufacturer	Index of string descriptor describing manufacturer = not supported	1	00H
15	iProduct	Index of string descriptor describing product = not supported	1	00H
16	iSerialNumber	Index of string descriptor describing device's serial no. = not supported	1	00H
17	bNumConfigurations	Number of possible configurations = 1	1	01H



## Configuration Descriptor

This Configuration Descriptor provides information about the AT43311's configuration.

Offset	Field	Description	Size (bytes)	Value
0	bLength	Define size of this descriptor = 9 bytes	1	09H
1	bDescriptorType	Descriptor type = Configuration	1	02H
2	wTotalLength	Total length of data returned for this configuration. Consists of the combined length of configuration, interface, endpoint and hub descriptors = 52 bytes	2	22H 00H
4	bNumInterface	Number of interfaces supported by this configuration.	1	01H
5	bConfigurationValue	Argument value for this configuration to be used by Set Configuration command	1	01H
6	iConfiguration	Index of string descriptor describing this configuration (not supported).	1	00H
7	bmAttributes	Configuration characteristics = Bus and Self Powered with Remote Wakeup	1	E0H
8	MaxPower	Maximum power consumption of USB device from bus = 100 mA	1	32H

## Interface Descriptor

The Interface Descriptor provides information about the single interface which the AT43311 supports.

Offset	Field	Description	Size (bytes)	Value
0	bLength	Define size of this descriptor = 9 bytes.	1	09H
1	bDescriptorType	Descriptor type = Interface	1	04H
2	bInterfaceNumber	Number of interface = 1, index = 0	1	00H
3	bAlternateSetting	Alternate setting value for the interface identified in the prior field = 0	1	00H
4	bNumEndpoints	Number of endpoints used by this interface = 1	1	01H
5	bInterfaceClass	Class code = HUB_CLASSCODE = 09	1	09H
6	bInterfaceSubClass	Subclass code = 0	1	00H
7	bInterfaceProtocol	Protocol code = 0	1	00H
8	iInterface	Index of string descriptor describing this interface = not supported	1	00H

## Endpoint Descriptor <sup>(1)</sup>

The Endpoint Descriptor describes the Endpoint1 Descriptor which the Hub uses for status change report.

Offset	Field	Description	Size (bytes)	Value
0	bLength	Define size of this descriptor = 7 bytes	1	07H
1	bDescriptorType	Descriptor type = endpoint	1	05H
2	bEndpointAddress	The address of the IN endpoint	1	81H
3	bmAttributes	Endpoint1 attribute =IN, Interrupt Transfer	1	03H
4	wMaxPacketSize	Max. packet size Endpoint1 is capable of sending = 1 byte	2	01H 00H
6	bInterval	Interval for polling endpoint for data transfers	1	FFH

Note: 1. There is no endpoint descriptor for Endpoint0.

## Hub Descriptor

The Hub Descriptor describes the AT43311's Hub and ports.

Offset	Field	Definition	Size (bytes)	Value
0	bDescLength	Define size of this descriptor = 9 bytes	1	09H
1	bDescriptorType	Descriptor Type = HUB_DESCRIPTOR = 29	1	29H
2	bNbrPorts	Number of downstream ports = 4	1	04H
3	wHubCharacteristics	Hub's characteristics: = Individual power switching = Hub is not part of a compound device = Individual Port Over-current Protection	2	09H 00H
5	bPwrOn2PwrGood	Time from the time power-on sequence begins on a port until power is good on that port = 100 ms.	1	32H
6	bHubContrCurrent	Maximum current requirements of the hub electronics = 100 mA.	1	64H
7	DeviceRemovable	Indicates if a port has removable device. All downstream ports have removable devices	1	00H
8	PortPwrCtrlMask	Indicates if a port is not affected by gang-mode power control request. All the AT43311's ports require manual SetPortFeature (PORT_POWER) request to control the port's power state.	1	1EH

## Standard Requests

All required Standard Requests are supported by the AT43311. Standard Requests, or commands, are sent to the AT43311 from the Host on the AT43311's default pipe, endpoint0. These requests are made using control transfers to endpoint0. The request and request parameters are sent in a Setup packet which consists of eight bytes. The following sections describe which requests are supported by the AT43311 and the corresponding responses as well as those requests not supported and responded with a STALL packet.

### Clear Device Feature

A Clear Device Feature will disable its remote wakeup feature when the setup packet is:

Field		Value
bmRequestType	Byte 0	x0000000B
bRequest	Byte 1	01H
wValue	Byte 2 Byte 3	01H 00H
wIndex	Byte 4 Byte 5	00H 00H
wLength	Byte 6 Byte 7	00H 00H

### Clear Interface Feature

AT43311 does not support this feature and will respond with a STALL if a setup packet from the Host is decoded as:

Field		Value
bmRequestType	Byte 0	x0000001B
bRequest	Byte 1	01H
wValue	Byte 2 Byte 3	xxH xxH
wIndex	Byte 4 Byte 5	xxH xxH
wLength	Byte 6 Byte 7	xxH xxH

## Clear Endpoint Feature

The Clear Endpoint Feature request causes the AT43311 to clear an endpoint's stall status bit if the condition causing the stall has been removed. A Clear Endpoint Feature occurs if a setup packet from the Host is decoded as:

Field		Value
bmRequestType	Byte 0	x0000002B
bRequest	Byte 1	01H
wValue	Byte 2 Byte 3	00H 00H
wIndex	Byte 4 Byte 5	00H for EP0 81H for EP1 00H
wLength	Byte 6 Byte 7	00H 00H

## Get Configuration

Get Configuration returns one byte of data. Bit 0 will be a copy of bit 0 of the Controller\_Status Register. All other bits will be set to 0. This action will be taken, if the Setup packet from host is decoded as:

Field		Value
bmRequestType	Byte 0	10000000B
bRequest	Byte 1	08H
wValue	Byte 2 Byte 3	00H 00H
wIndex	Byte 4 Byte 5	00H 00H
wLength	Byte 6 Byte 7	01H 00H

## Get\_Descriptor

Get\_Descriptor returns the requested descriptor. The last word of the Get\_Descriptor request specifies the number of bytes the AT43311 is to return. If the requested descriptor is longer than the requested number of bytes, AT43311 will return only the requested number of bytes from the top of the descriptor. If the requested descriptor is shorter than the requested number of bytes, then the AT43311 indicates the end of the control transfer by sending a short data packet.

The requested number of bytes from the top of AT43311's Device Descriptor will be returned, if the Setup packet from host is decoded as:

Field		Value
bmRequestType	Byte 0	10000000B
bRequest	Byte 1	06H
wValue	Byte 2 Byte 3	00H 01H
wIndex	Byte 4 Byte 5	00H 00H
wLength	Byte 6 Byte 7	# of bytes requested

The requested number of bytes from AT43311's Configuration Descriptor, Interface Descriptor, and Endpoint Descriptor will be returned, if the Setup packet from the Host is decoded as:

Field		Value
bmRequestType	Byte 0	10000000B
bRequest	Byte 1	06H
wValue	Byte 2 Byte 3	00H 02H
wIndex	Byte 4 Byte 5	00H 00H
wLength	Byte 6 Byte 7	# of bytes requested

## Get\_Interface

The AT43311 has a single interface with a value of 0. If it receives a Get\_Interface Request with the value of 0000H as wIndex (bytes 2 and 3), the AT43311 will return a single byte with a value of 00H. For any other value of wIndex the AT43311 will return a STALL.

Field		Value
bmRequestType	Byte 0	10000001B
bRequest	Byte 1	0AH
wValue	Byte 2 Byte 3	00H 00H
wIndex	Byte 4 Byte 5	00H 00H
wLength	Byte 6 Byte 7	01H 00H

## Get Device Status

If the Setup packet from host is decoded as:

Field		Value
bmRequestType	Byte 0	10000000B
bRequest	Byte 1	00H
wValue	Byte 2 Byte 3	00H 00H
wIndex	Byte 4 Byte 5	00H 00H
wLength	Byte 6 Byte 7	02H 00H

The Hub will return two bytes of data, byte 0 and byte 1, in little endian order:

Byte 0, Bit 0 = 1, identifying the AT43311 as a self-powered device.

Byte 0, Bit 1 = copy of bit 1 of the Controller\_Status Register. This bit reflects whether the AT43311's remote wakeup capability is enabled or disabled.

All other bits are set to 0.

## Get Interface Status

If the Setup packet from host is decoded as:

Field		Value
bmRequestType	Byte 0	10000001B
bRequest	Byte 1	0x00
wValue	Byte 2 Byte 3	0x00 0x00
wIndex	Byte 4 Byte 5	0xxx 0xxx
wLength	Byte 6 Byte 7	0x02 0x00

The Hub will respond with two bytes of data with all 0 value.

## Get Endpoint Status

Get Endpoint Status returns two-bytes of data indicating the stall status of the endpoint. The first bit of the first byte returned reflects the status of the endpoint stall status bits of the Controller\_Status Register described in section 3.6. These bits are set or cleared depending whether the endpoint is stalled or not:

Current Endpoint Status	First Byte	Second Byte
Stalled	01H	00H
Not stalled	00H	00H

Get Endpoint Status will execute if the following setup packet is decoded as:

Field		Value
bmRequestType	Byte 0	10000010B
bRequest	Byte 1	00H
wValue	Byte 2 Byte 3	00H 00H
wIndex	Byte 4 Byte 5	x0000001B for EP0 10000001B for EP1 00H
wLength	Byte 6 Byte 7	02H 00H

## Set\_Address

Set\_Address sets the Hub's address. The AT43311 will save the value of bytes 2 and 3 into a temporary buffer. After successful completion of the status stage, the AT43311 transfers the temporary value into the Hub\_Address Register. The Hub\_Address will be used as the Hub's address in all future transactions. Set\_Address will occur if the Setup packet from the Host is decoded as:

Field		Value
bmRequestType	Byte 0	x0000000B
bRequest	Byte 1	05H
wValue	Byte 2 Byte 3	Device Address
wIndex	Byte 4 Byte 5	00H 00H
wLength	Byte 6 Byte 7	00H 00H

## Set\_Configuration

Set\_Configuration sets bit 0 of the Controller\_Status Register according to the value of byte 2 of the Setup packet. The AT43311 has only one configuration. The AT43311 will only set the bit if byte 2 is either 00H or 01H, and bytes 3 to 7 are all zeroes. For all other values, the Hub will respond with a STALL handshake packet. Set\_Configuration occurs if the Setup packet from host is decoded as:

Field		Value
bmRequestType	Byte 0	x0000000B
bRequest	Byte 1	09H
wValue	Byte 2 Byte 3	00H or 01H 00H
wIndex	Byte 4 Byte 5	00H 00H
wLength	Byte 6 Byte 7	00H 00H

## Set\_Descriptor

The AT43311 does not support this request. In response to this request, the AT43311 will send a STALL handshake packet. The Set\_Descriptor occurs if the Setup packet from the Host is decoded as:

Field		Value
bmRequestType	Byte 0	00000000B
bRequest	Byte 1	07H
wValue	Byte 2 Byte 3	xxH xxH
wIndex	Byte 4 Byte 5	xxH xxH
wLength	Byte 6 Byte 7	xxH xxH

## Set Device Feature

Set Device Feature enables the remote wakeup feature if a setup packet from the Host is decoded as:

Field		Value
bmRequestType	Byte 0	x0000000B
bRequest	Byte 1	03H
wValue	Byte 2 Byte 3	01H 00H
wIndex	Byte 4 Byte 5	00H 00H
wLength	Byte 6 Byte 7	00H 00H

## Set Interface Feature

AT43311 does not support this feature and will respond with a STALL if a setup packet from the Host is decoded as:

Field		Value
bmRequestType	Byte 0	x0000001B
bRequest	Byte 1	03H
wValue	Byte 2 Byte 3	xxH xxH
wIndex	Byte 4 Byte 5	xxH xxH
wLength	Byte 6 Byte 7	xxH xxH

## Set Endpoint Feature

Set Endpoint Feature sets the stall status bit of the Controller\_Status Register. The stalled endpoint will exhibit the same behavior as in a stall condition. This feature is activated if a setup packet from the Host is decoded as:

Field		Value
bmRequestType	Byte 0	x0000010B
bRequest	Byte 1	03H
wValue	Byte 2 Byte 3	00H 00H
wIndex	Byte 4 Byte 5	00H for EP0 81H for EP1 00H
wLength	Byte 6 Byte 7	00H 00H

## Set Interface

The AT43311 has a single interface and responds with a STALL handshake packet if a Set\_Interface request is received with a value other than 0000H as a wValue (bytes 2 and 3).

Field		Value
bmRequestType	Byte 0	x0000001B
bRequest	Byte 1	0BH
wValue	Byte 2 Byte 3	00H 00H
wIndex	Byte 4 Byte 5	00H 00H
wLength	Byte 6 Byte 7	00H 00H

## Sync\_Frame

This request is for endpoints with isochronous transfers only which the AT43311 does not support. AT43311 will send a STALL packet if the setup packet from the Host is decoded as:

Field		Value
bmRequestType	Byte 0	10000001B
bRequest	Byte 1	0CH
wValue	Byte 2 Byte 3	xxH xxH
wIndex	Byte 4 Byte 5	xxH xxH
wLength	Byte 6 Byte 7	xxH xxH

## Hub-specific Requests

All required Hub-specific requests are supported by the AT43311's Hub Controller. Hub-specific requests or commands are sent from the Host to the AT43311 using the default pipe (Endpoint0). Hub-specific requests are made using control transfers. The request and request parameters are sent in a setup packet consisting of eight bytes.

### Clear\_Hub\_Feature

Clear\_Hub\_Feature resets a value reported in the Hub Controller status. The status relates to the local power and over current. AT43311 is a self-powered hub with a bus-powered SIE and does not report over-current on a global basis.

The Hub Controller will disable the reporting of Local Power Status (C\_HUB\_LOCAL\_POWER) if the setup packet from the Host is decoded as:

Field		Value
bmRequestType	Byte 0	x0100000B
bRequest	Byte 1	01BH
wValue	Byte 2 Byte 3	00H 00H
wIndex	Byte 4 Byte 5	00H 00H
wLength	Byte 6 Byte 7	00H 00H

AT43311 will respond with a STALL if the setup packet from the Host requests the Hub Controller to clear the Over Current Indicator (C\_HUB\_OVER\_CURRENT):

Field		Value
bmRequestType	Byte 0	x0100000B
bRequest	Byte 1	01H
wValue	Byte 2 Byte 3	01H 00H
wIndex	Byte 4 Byte 5	00H 00H
wLength	Byte 6 Byte 7	00H 00H

### Clear\_Port\_Feature

Clear\_Port\_Feature disables a port feature. Note that only the relevant Clear Port commands are supported (see CLEAR\_PORT Features Table).

For example, the PORT\_LOW\_SPEED value is determined by the operation of the port of the attached device. Upon an invalid request (e.g. a CLEAR\_PORT request for PORT\_LOW\_SPEED), the AT43311 will return a STALL status to the host.

#### CLEAR\_PORT Features Table

Port Feature	ClearPort Feature	SetPort Feature
PORT_CONNECTION	N	N
PORT_ENABLE	Y	Y
PORT_SUSPEND	Y	Y
PORT_OVER_CURRENT	Y	N
PORT_RESET	N	Y
PORT_POWER	Y	Y
PORT_LOW_SPEED	N	N

The Hub Controller will respond to a Clear Port Feature request if the setup packet from the Host is decoded as:

Field		Value
bmRequestType	Byte 0	x0100011B
bRequest	Byte 1	01H
wValue	Byte 2 Byte 3	See Port Feature Selector Table
wIndex	Byte 4 Byte 5	Port Number
wLength	Byte 6 Byte 7	00H 00H

### Port Feature Selector Table

Feature	Value
PORT_CONNECTION	00H
PORT_ENABLE	01H
PORT_SUSPEND	02H
PORT_OVER_CURRENT	03H
PORT_RESET	04H
PORT_POWER	08H
PORT_LOW_SPEED	09H
C_PORT_CONNECTION	10H
C_PORT_ENABLE	11H
C_PORT_SUSPEND	12H
C_PORT_OVER_CURRENT	13H
C_PORT_RESET	14H

The Hub Controller will respond with a STALL if Port0 or a port higher than Port4 is addressed in this request.

### Get\_Bus\_State

When a Get\_Bus\_State is detected, the Hub Controller will sample the bus status of Ports 1, 2, 3 and 4, at each EOF2 and will store the value in a register known as the Port\_Bus\_State registers. The value of the D- signal (pin DM[1:4]) will be in bit 0 and the value of the D+ signal (DP[1:4]) will be in bit 1 of each port's Port\_Bus\_State register. All other bits will be 0. The values of these two register bits will be transferred to the Host upon receipt of the Get\_Bus\_State request, if the setup packet from Host is decoded as:

Field		Value
bmRequestType	Byte 0	10100011B
bRequest	Byte 1	02H
wValue	Byte 2 Byte 3	00H 00H
wIndex	Byte 4 Byte 5	Port Number
wLength	Byte 6 Byte 7	01H 00H

The Hub Controller will respond with a STALL if Port0 or a port higher than Port4 is addressed in this request.

### Get\_Hub\_Descriptor

Get\_Hub\_Descriptor returns the Hub Descriptor. The last word of the Get\_Hub\_Descriptor request specifies the number of bytes AT43311 is to return. If the requested number of bytes is less than the 9-bytes length of the Hub Descriptor, AT43311 will return only the requested number of bytes from the top of the descriptor. If the requested number of bytes is more than 9, then the returned data will be padded with trailing bytes of zeroes.

This action will be taken if the Setup packet from the Host is decoded as:

Field		Value
bmRequestType	Byte 0	10100000B
bRequest	Byte 1	06H
wValue	Byte 2 Byte 3	29H 00H
wIndex	Byte 4 Byte 5	00H 00H
wLength	Byte 6 Byte 7	Number of Bytes Requested



## Get\_Hub\_Status

Get\_Hub\_Status returns the current Hub status that has changed since the previous acknowledgment of the setup packet of the Host.

The Hub will returned two words of data as described in the following two tables. Word0 is the Hub Status Field, wHubStatus, and Word1 is the Hub Change Field,wHubChange.

### Hub Status Field, wHubStatus

Bit	Description
0	Local Power Status, indicates the state of the local power supply 0 = Local power supply good 1 = Local power supply lost
1	Over-Current Indicator, indicates over-current condition on a global hub basis. AT43311 reports over current condition on a per port basis therefore this bit is always read as 0
2-15	Reserved. Always read as 0's

### Hub Change Field, wHubChange

Bit	Description
0	Local Power Status Change, C_HUB_LOCAL_POWER, corresponds to bit 0 of wHubStatus 0 = No change has occurred in local power status 1 = Local power status has changed
1	Over-Current Indicator Change, C_HUB_OVER_CURRENT, corresponds to bit 1 of wHubStatus. AT43311 reports over current condition on a per port basis and therefore this bit is always read as 0
2-15	Reserved. Always read as 0's.

A Get\_Hub\_Status will occur if the setup packet is decoded as:

Field		Value
bmRequestType	Byte 0	10100000B
bRequest	Byte 1	00H
wValue	Byte 2 Byte 3	01H 00H
wIndex	Byte 4 Byte 5	00H 00H
wLength	Byte 6 Byte 7	04H 00H

## Get\_Port\_Status

Get\_Port\_Status returns the current port status and the states that have changed since the previous acknowledgment. The AT43311 returns two words of data as described in the following two tables. Word0 is the Port Status Field, and Word1 is the Port Change Field. The AT43311 will respond with a STALL if Port0 or a port higher than Port4 is addressed in this request.

### Port Status Field, wPortStatus

Bit	Description
0	Current Connect Status: PORT_CONNECTION 0 = no device present on this port 1 = a device is present on this port
1	Port Enabled/Disabled: PORT_ENABLE 0 = Port is disabled 1 = Port is enabled
2	Suspend: PORT_SUSPEND 0 = Not suspended 1 = Suspended
3	Over-Current Indicator: PORT_OVER_CURRENT 0 = Power operation normal for this port 1 = Over-current condition exists for this port. Power to this port has been shut off.
4	Reset: PORT_RESET 0 = Reset signalling not asserted 1 = Reset signalling asserted
5-7	Reserved. Always read as 0's.
8	Port Power: PORT_POWER 0 = This port is powered OFF 1 = This port is powered ON
9	Low Speed Device Attached: PORT_LOW_SPEED 0 = Full Speed device attached to this port 1 = Low Speed device attached to this port
10-15	Reserved. Always read as 0's

## Port Change Field, wPortChange

Bit	Description
0	Connect Status Change: C_PORT_CONNECTION 0 = No change has occurred on Current Connect status 1 = Current Connect Status has changed
1	Port Enable/Disable Change: C_PORT_ENABLE 0 = No change has occurred on Port Enabled/Disabled status 1 = Port Enabled/Disabled status has changed
2	Suspend Change: C_PORT_SUSPEND 0 = No change 1 = Resume complete
3	Over-Current Indicator Change: C_PORT_OVER_CURRENT 0 = No change has occurred on Over-Current indicator 1 = Over-Current indicator has changed
4	Reset Change: C_PORT_RESET 0 = No change 1 = Reset complete
5-15	Reserved. Always read as 0's.

Get\_Port\_Status occurs if the setup packet from host is decoded as:

Field		Value
bmRequestType	Byte 0	10100011B
bRequest	Byte 1	00BH
wValue	Byte 2 Byte 3	00H 00H
wIndex	Byte 4 Byte 5	Port Number
wLength	Byte 6 Byte 7	04H 00H

## Set\_Hub\_Descriptor

The AT43311 has only one Hub Descriptor. Therefore the AT43311 does not support this request. It will respond with a STALL if the Setup packet from the Host is decoded as:

Field		Value
bmRequestType	Byte 0	00100000B
bRequest	Byte 1	07H
wValue	Byte 2 Byte 3	xxH xxH
wIndex	Byte 4 Byte 5	xxH xxH
wLength	Byte 6 Byte 7	xxH xxH

## Set\_Hub\_Feature

Set\_Hub\_Feature sets a value reported in the Hub status. The status relates to the local power and over current. The AT43311 is a self powered hub with its SIE powered from the bus. The AT43311 will respond with a STALL if the setup packet from the Host is decoded as:

Field		Value
bmRequestType	Byte 0	x0100000B
bRequest	Byte 1	03H
wValue	Byte 2 Byte 3	xxH xxH
wIndex	Byte 4 Byte 5	xxH xxH
wLength	Byte 6 Byte 7	xxH xxH

## Set\_Port\_Feature

Set\_Port\_Feature sets a value reported in the Hub Controller's port status. The AT43311 supports all USB required features. Note that only the relevant Set Port commands are supported (see SET\_PORT Features Table). For example, the PORT\_LOW\_SPEED value is determined by the operation of the port of the attached device. Upon an invalid request (e.g. a Set\_PORT request for PORT\_LOW\_SPEED), the AT43311 will return a STALL status to the host.

### SET\_PORT Features Table

Port Feature	ClearPort Feature	SetPort Feature
PORT_CONNECTION	N	N
PORT_ENABLE	Y	Y
PORT_SUSPEND	Y	Y
PORT_OVER_CURRENT	Y	N
PORT_RESET	N	Y
PORT_POWER	Y	Y
PORT_LOW_SPEED	N	N

The status relates to the port features as listed in the Port Feature Table. AT43311 will respond to Set Port Feature command if the setup packet from the Host is decoded as:

Field		Value
bmRequestType	Byte 0	x0100011B
bRequest	Byte 1	03H
wValue	Byte 2 Byte 3	See Port Feature Selector Table
wIndex	Byte 4 Byte 5	Port Number
wLength	Byte 6 Byte 7	00H 00H

### Port Feature Selector Table

Feature	Value
PORT_CONNECTION	00H
PORT_ENABLE	01H
PORT_SUSPEND	02H
PORT_OVER_CURRENT	03H
PORT_RESET	04H
PORT_POWER	08H
PORT_LOW_SPEED	09H
C_PORT_CONNECTION	10H
C_PORT_ENABLE	11H
C_PORT_SUSPEND	12H
C_PORT_OVER_CURRENT	13H
C_PORT_RESET	14H

## Absolute Maximum Ratings

Operating Temperature .....	-55°C to +125°C
Storage Temperature .....	-65°C to +150°C
Voltage on any pin with Respect to Ground .....	-0.5V to 7.0V
Maximum Operating Voltage .....	6.6V
DC Output Current .....	16 mA

\*NOTICE: Stresses beyond those listed below may cause permanent damage to the device. This is a stress rating only and functional operation of the device at these or any other conditions beyond those indicated in the operational sections of this specification is not implied. Exposure to absolute maximum rating conditions for extended periods may affect device reliability.

## DC Characteristics

The values shown in this table are valid for  $T_A = 0^\circ\text{C}$  to  $85^\circ\text{C}$ ,  $V_{CC5} = 4.4$  to  $5.25\text{V}$ ,  $V_{CC3} = 3\text{V} \pm 5\%$ , unless otherwise noted.

### Power Supply

Symbol	Parameter	Condition	Min	Max	Unit
$V_{CC5}, V_{CCA}$	5V Power Supply		4.40	5.25	V
$V_{CC3}$	3V Power Supply		3.15	3.45	V
$I_{CC5}$	5V Supply Current			100	mA
$I_{CC3}$	3V Supply Current			250	$\mu\text{A}$
$I_{CCS}$	Suspended Device Current			250	$\mu\text{A}$

### USB Signals: DPx, DMx

Symbol	Parameter	Condition	Min	Max	Unit
$I_{LO}$	Hi-Z Data Line Leakage	$0\text{V} < V_{IN} < 3.3\text{V}$	-10	+10	$\mu\text{A}$
$V_{DI}$	Differential Input Sensitivity	DPx and DMx	0.2		V
$V_{CM}$	Differential Common Mode Range		0.8	2.5	V
$V_{SE}$	Single Ended Receiver Threshold		0.8	2.0	V
$V_{OL1}$	Static Output Low Voltage	RL of 1.5K $\Omega$ to 3.6V		0.3	V
$V_{OH1}$	Static Output High Voltage	RL of 15K $\Omega$ to GND	2.8	3.6	V

### PWR[1:4], STAT[1:4]

Symbol	Parameter	Condition	Min	Max	Unit
$V_{OL1}$	Output Low Level, STAT[1:4]	$I_{OL} = 8\text{ mA}$		0.5	V
$V_{OH1}$	Output High Level, STAT[1:4]	$I_{OH} = 8\text{ mA}$	$V_{CC5} - 0.5\text{V}$		V
$V_{OL2}$	Output Low Level, PWR[1:4]	$I_{OL} = 4\text{ mA}$		0.5	V
$C_{OUT}$	Output capacitance	1 MHz		10	pF

## Oscillator Signals: OSC1, OSC2 <sup>(1)</sup>

Symbol	Parameter	Condition	Min	Max	Unit
$f_{OSC}$	Oscillator Frequency	6 MHz $\pm$ 0.25%	5.985	6.015	MHz
$V_{LH}$	OSC1 switching level		0.47	1.20	V
$V_{HL}$	OSC1 switching level		0.67	1.44	V
$C_{X1}$	Input capacitance, OSC1			9	pF
$C_{X2}$	Output capacitance, OSC2			9	pF
$C_{1/2}$	OSC1/2 capacitance			1	pF
$t_{SU}$	Start-up time	6 MHz, fundamental		10	ms
$D_L$	Drive level	$V_{CC5} = 5V$ , 6 MHz crystal, 120 $\Omega$ equiv series resistor		5	mW

Note: 1. OSC2 must not be used to drive other circuitry.

## Comparator Signals: VREF, $\overline{OVL[1:4]}$

Symbol	Parameter	Condition	Min	Max	Unit
$V_{OS}$	Input Offset voltage		-20	+20	mV
$A_O$	Open loop gain		80		dB
$CM_{IRL}$	Input CM range low			0	V
$CM_{IRH}$	Input CM range high		$V_{CC5}$		V
$CM_{RR}$	CM rejection ratio	1 KHz	92		dB
$C_{INR}$	Input capacitance, VREF#			10	pF
$C_{INL}$	Input capacitance, all other			6	pF

## AC Characteristics

### Dpx, Dmx Driver Characteristics, Full Speed Operation

Symbol	Parameter	Condition	Min	Max	Unit
$T_R$	Rise time	$C_L = 50$ pF	4	20	ns
$T_F$	Fall time	$C_L = 50$ pF	4	20	ns
TRFM	TR/TF matching		90	110	%
$V_{CRS}$	Output signal crossover		1.3	2.0	V
$Z_{DRV}$	Driver output resistance	Steady state drive	28	43	$\Omega$

## Dpx, Dmx Data Source Timings, Full Speed Operation

Symbol	Parameter	Condition	Min	Max	Unit
$T_{DRATE}$	Full Speed Data Rate	Average Bit Rate	11.97	12.03	Mbs
$T_{FRAME}$	Frame Interval		0.9995	1.0005	ms
$T_{DJ1}$ $T_{DJ2}$	Source Diff Driver Jitter To Next Transition For Paired Transitions		-3.5 -4.0	3.5 4.0	ns ns
$T_{EOPT}$	Source EOP Width		160	175	ns
$T_{DEOP}$	Differential to EOP Transition Skew		-2	5	ns
$T_{JR1}$ $T_{JR2}$	Recvr Data Jitter Tolerance To Next Transition For Paired Transitions		-18.5 -9	18.5 9	ns ns
$T_{EOPR1}$ $T_{EOPR2}$	EOP Width at Receiver Must Reject as EOP Must Receive as EOP		40 82		ns ns

## DPx, DMx Driver Characteristics, Low Speed Operation

Symbol	Parameter	Condition	Min	Max	Unit
$T_R$	Rise time	$C_L = 50 \text{ pF}$	75		ns
$T_R$	Rise time	$C_L = 350 \text{ pF}$		300	ns
$T_F$	Fall time	$C_L = 50 \text{ pF}$	75		ns
$T_F$	Fall time	$C_L = 350 \text{ pF}$		300	ns
TRFM	TR/TF matching		80	120	%
$V_{CRS}$	Output signal crossover		1.3	2.0	V

## Dpx, Dmx Hub Timings, High Speed Operation

Symbol	Parameter	Condition	Min	Max	Unit
$T_{HDD1}$ $T_{HDD2}$	Hub Differential Data Delay with cable without cable			70 40	ns ns
$T_{HDJ1}$ $T_{HDJ2}$	Hub Diff Driver Jitter To Next Transition For Paired Transitions		-3 -1	3 1	ns ns
$T_{SOP}$	Data Bit Width Distortion after SOP		-5	3	ns
$T_{EOPD}$	Hub EOP Delay Relative to THDD		0	15	ns
$T_{HESK}$	Hub EOP Output Width Skew		-15	15	ns

## Dpx, Dmx Hub Timings, Low Speed Operation

Symbol	Parameter	Condition	Min	Max	Unit
$T_{LHDD}$	Hub Differential Data Delay			300	ns
$T_{LHDJ1}$ $T_{LHDJ2}$	Downstr Hub Diff Driver Jitter To Next Transition For Paired Transitions		-45 -15	45 15	ns ns
$T_{SOP}$	Data Bit Width Distortion after SOP		-60	45	ns
$T_{LEOPD}$	Hub EOP Delay Relative to THDD		0	200	ns
$T_{LHESK}$	Hub EOP Output Width Skew		-300	300	ns