

### FEATURES

#### Computes

- True rms value
- Average rectified value
- Absolute value

#### Provides

- 200 mV full-scale input range (larger inputs with input attenuator)
- Direct interfacing with 3½ digit CMOS ADCs
- High input impedance:  $10^{12} \Omega$
- Low input bias current: 25 pA maximum
- High accuracy:  $\pm 0.2 \text{ mV} \pm 0.3\%$  of reading
- RMS conversion with signal crest factors up to 5
- Wide power supply range:  $\pm 2.5 \text{ V}$  to  $\pm 16.5 \text{ V}$
- Low power: 160  $\mu\text{A}$  maximum supply current
- No external trims needed for specified accuracy
- A general-purpose, buffered voltage output version also available (AD736)

### GENERAL DESCRIPTION

The AD737<sup>1</sup> is a low power, precision, monolithic true rms-to-dc converter. It is laser trimmed to provide a maximum error of  $\pm 0.2 \text{ mV} \pm 0.3\%$  of reading with sine wave inputs. Furthermore, it maintains high accuracy while measuring a wide range of input waveforms, including variable duty cycle pulses and triac (phase) controlled sine waves. The low cost and small physical size of this converter make it suitable for upgrading the performance of non-rms precision rectifiers in many applications. Compared to these circuits, the AD737 offers higher accuracy at equal or lower cost.

The AD737 can compute the rms value of both ac and dc input voltages. It can also be operated ac-coupled by adding one external capacitor. In this mode, the AD737 can resolve input signal levels of 100  $\mu\text{V}$  rms or less, despite variations in temperature or supply voltage. High accuracy is also maintained for input waveforms with crest factors of 1 to 3. In addition, crest factors as high as 5 can be measured (while introducing only 2.5% additional error) at the 200 mV full-scale input level.

The AD737 has no output buffer amplifier, thereby significantly reducing dc offset errors occurring at the output, which makes the device highly compatible with high input impedance ADCs.

Requiring only 160  $\mu\text{A}$  of power supply current, the AD737 is optimized for use in portable multimeters and other battery-powered applications. This converter also provides a power-down feature that reduces the power-supply standby current to less than 30  $\mu\text{A}$ .

<sup>1</sup> Protected under U.S. Patent Number 5,495,245.

#### Rev. G

Information furnished by Analog Devices is believed to be accurate and reliable. However, no responsibility is assumed by Analog Devices for its use, nor for any infringements of patents or other rights of third parties that may result from its use. Specifications subject to change without notice. No license is granted by implication or otherwise under any patent or patent rights of Analog Devices. Trademarks and registered trademarks are the property of their respective owners.

### FUNCTIONAL BLOCK DIAGRAM

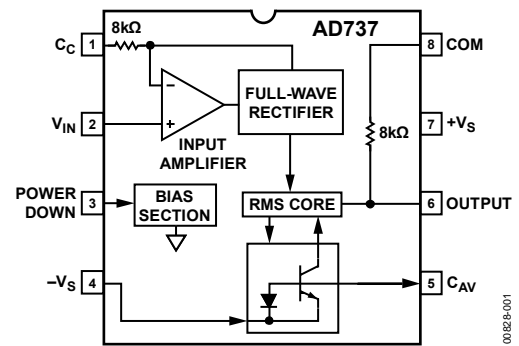

Figure 1.

Two signal input terminals are provided in the AD737. A high impedance ( $10^{12} \Omega$ ) FET input interfaces directly with high R input attenuators, and a low impedance (8 k $\Omega$ ) input accepts rms voltages to 0.9 V while operating from the minimum power supply voltage of  $\pm 2.5 \text{ V}$ . The two inputs can be used either single ended or differentially.

The AD737 achieves 1% of reading error bandwidth, exceeding 10 kHz for input amplitudes from 20 mV rms to 200 mV rms, while consuming only 0.72 mW.

The AD737 is available in four performance grades. The AD737J and AD737K grades are rated over the commercial temperature range of 0°C to 70°C. The AD737JR-5 is tested with supply voltages of  $\pm 2.5 \text{ V}$  dc. The AD737A and AD737B grades are rated over the industrial temperature range of  $-40^\circ\text{C}$  to  $+85^\circ\text{C}$ . The AD737 is available in three low cost, 8-lead packages: PDIP, SOIC\_N, and Cerdip.

### PRODUCT HIGHLIGHTS

1. Capable of computing the average rectified value, absolute value, or true rms value of various input signals.
2. Only one external component, an averaging capacitor, is required for the AD737 to perform true rms measurement.
3. The low power consumption of 0.72 mW makes the AD737 suitable for battery-powered applications.

## TABLE OF CONTENTS

Features .....	1	AC Measurement Accuracy and Crest Factor .....	13
Functional Block Diagram .....	1	Calculating Settling Time.....	13
General Description .....	1	Applications.....	14
Product Highlights .....	1	RMS Measurement—Choosing Optimum Value for $C_{AV}$ .....	14
Revision History .....	2	Rapid Settling Times via the Average Responding Connection.....	14
Specifications.....	3	Selecting Practical Values for Capacitors .....	14
Absolute Maximum Ratings.....	6	Scaling Input and Output Voltages .....	14
Thermal Resistance .....	6	AD737 Evaluation Board.....	18
ESD Caution.....	6	Outline Dimensions .....	20
Pin Configurations and Function Descriptions .....	7	Ordering Guide .....	21
Typical Performance Characteristics .....	8		
Theory of Operation .....	12		
Types of AC Measurement .....	12		
DC Error, Output Ripple, and Averaging Error .....	13		

## REVISION HISTORY

### 12/06—Rev. F to Rev. G

Changes to Specifications .....	3
Reorganized Typical Performance Characteristics .....	8
Changes to Figure 21 .....	11
Reorganized Theory of Operation Section .....	12
Reorganized Applications Section.....	14
Added Scaling Input and Output Voltages Section.....	14
Deleted Application Circuits Heading.....	16
Changes to Figure 28.....	16
Added AD737 Evaluation Board Section.....	18
Updated Outline Dimensions .....	20
Changes to Ordering Guide .....	21

### 1/05—Rev. E to Rev. F

Updated Format .....	Universal
Added Functional Block Diagram.....	1
Changes to General Description Section .....	1
Changes to Pin Configurations and Function Descriptions Section .....	6
Changes to Typical Performance Characteristics Section.....	7
Changes to Table 4.....	11
Change to Figure 24 .....	12
Change to Figure 27 .....	15
Changes to Ordering Guide .....	18

### 6/03—Rev. D to Rev. E

Added AD737JR-5.....	Universal
Changes to Features .....	1
Changes to General Description .....	1
Changes to Specifications.....	2
Changes to Absolute Maximum Ratings.....	4
Changes to Ordering Guide .....	4
Added TPCs 16 through 19 .....	6
Changes to Figures 1 and 2 .....	8
Changes to Figure 8.....	11
Updated Outline Dimensions .....	12

### 12/02—Rev. C to Rev. D

Changes to Functional Block Diagram.....	1
Changes to Pin Configuration .....	4
Figure 1 Replaced .....	8
Changes to Figure 2.....	8
Figure 5 Replaced .....	10
Changes to Application Circuits Figures 4, 6–8 .....	10
Outline Dimensions Updated.....	12

### 12/99—Rev. B to Rev. C

## SPECIFICATIONS

$T_A = 25^\circ\text{C}$ ,  $\pm V_S = \pm 5\text{ V}$  except as noted,  $C_{AV} = 33\ \mu\text{F}$ ,  $C_C = 10\ \mu\text{F}$ ,  $f = 1\ \text{kHz}$ , sine wave input applied to Pin 2, unless otherwise specified. Specifications shown in **boldface** are tested on all production units at final electrical test. Results from these tests are used to calculate outgoing quality levels.

**Table 1.**

Parameter	Conditions	AD737A, AD737J			AD737B, AD737K			AD737J-5			Unit
		Min	Typ	Max	Min	Typ	Max	Min	Typ	Max	
<b>ACCURACY</b>											
Total Error	$E_{IN} = 0$ to 200 mV rms $\pm V_S = \pm 2.5\text{ V}$ $\pm V_S = \pm 2.5\text{ V}$ , input to Pin 1 $E_{IN} = 200$ mV to 1 V rms		0.2/0.3	<b>0.4/0.5</b>		0.2/0.2	<b>0.2/0.3</b>		0.2/0.3	<b>0.4/0.5</b>	$\pm\text{mV}/\pm\text{POR}^1$ POR POR POR
Over Temperature			-1.2	<b><math>\pm 2.0</math></b>		-1.2	<b><math>\pm 2.0</math></b>				POR
AQ and BQ	$E_{IN} = 200$ mV rms			<b>0.5/0.7</b>			<b>0.3/0.5</b>				$\pm\text{POR}/^\circ\text{C}$
JN, JR, KN, KR	$E_{IN} = 200$ mV rms, $\pm V_S = \pm 2.5\text{ V}$		0.007			0.007			0.02		$\pm\text{POR}/^\circ\text{C}$
AN and AR	$E_{IN} = 200$ mV rms, $\pm V_S = \pm 2.5\text{ V}$		0.014			0.014					$\pm\text{POR}/^\circ\text{C}$
Vs. Supply Voltage											
	$E_{IN} = 200$ mV rms, $\pm V_S = \pm 2.5\text{ V}$ to $\pm 5\text{ V}$	<b>0</b>	-0.18	<b>-0.3</b>	<b>0</b>	-0.18	<b>-0.3</b>	<b>0</b>	-0.18	<b>-0.3</b>	%/V
	$E_{IN} = 200$ mV rms, $\pm V_S = \pm 5\text{ V}$ to $\pm 16.5\text{ V}$	<b>0</b>	0.06	<b>0.1</b>	<b>0</b>	0.06	<b>0.1</b>	<b>0</b>	0.06	<b>0.1</b>	%/V
DC Reversal Error	DC coupled, $V_{IN} = 600$ mV dc $V_{IN} = 200$ mV dc, $\pm V_S = \pm 2.5\text{ V}$		1.3	2.5		1.3	2.5				POR POR
Nonlinearity <sup>2</sup>	$E_{IN} = 0$ to 200 mV rms, @ 100 mV rms	<b>0</b>	0.25	<b>0.35</b>	<b>0</b>	0.25	<b>0.35</b>				POR
Input to Pin 1 <sup>3</sup>	AC coupled, $E_{IN} = 100$ mV rms, after correction, $\pm V_S = \pm 2.5\text{ V}$								0.02	0.1	POR
Total Error, External Trim	$E_{IN} = 0$ to 200 mV rms		0.1/0.2			0.1/0.2			0.1/0.2		$\pm\text{mV}/\pm\text{POR}$
<b>ADDITIONAL CREST FACTOR ERROR<sup>4</sup></b>											
For Crest Factors from 1 to 3	$C_{AV} = C_F = 100\ \mu\text{F}$		0.7			0.7					% %
	$C_{AV} = 22\ \mu\text{F}$ , $C_F = 100\ \mu\text{F}$ , $\pm V_S = \pm 2.5\text{ V}$ , input to Pin 1								1.7		%
For Crest Factors from 3 to 5	$C_{AV} = C_F = 100\ \mu\text{F}$		2.5			2.5					%
<b>INPUT CHARACTERISTICS</b>											
High-Z Input (Pin 2) Signal Range											
Continuous RMS Level	$\pm V_S = +2.5\text{ V}$									<b>200</b>	mV rms
	$\pm V_S = +2.8\text{ V}/-3.2\text{ V}$			<b>200</b>			<b>200</b>				mV rms
	$\pm V_S = \pm 5\text{ V}$ to $\pm 16.5\text{ V}$			<b>1</b>			<b>1</b>				V rms

# AD737

Parameter	Conditions	AD737A, AD737J			AD737B, AD737K			AD737J-5			Unit	
		Min	Typ	Max	Min	Typ	Max	Min	Typ	Max		
Peak Transient Input	$\pm V_S = +2.5\text{ V}$ input to Pin 1							$\pm 0.6$			V	
	$\pm V_S = +2.8\text{ V}/-3.2\text{ V}$	$\pm 0.9$				$\pm 0.9$					V	
	$\pm V_S = \pm 5\text{ V}$		$\pm 2.7$				$\pm 2.7$				V	
	$\pm V_S = \pm 16.5\text{ V}$	$\pm 4.0$				$\pm 4.0$					V	
Input Resistance			1012		1012			1012			$\Omega$	
Input Bias Current	$\pm V_S = \pm 5\text{ V}$		1	25		1	25		1	25	pA	
Low-Z Input (Pin 1) Signal Range	$\pm V_S = +2.5\text{ V}$									300	mV rms	
	$\pm V_S = +2.8\text{ V}/-3.2\text{ V}$			300			300				mV rms	
Peak Transient Input	$\pm V_S = \pm 5\text{ V to } \pm 16.5\text{ V}$			1			1				V rms	
	$\pm V_S = +2.5\text{ V}$							$\pm 1.7$			V	
Input Resistance	$\pm V_S = +2.8\text{ V}/-3.2\text{ V}$		$\pm 1.7$			$\pm 1.7$					V	
	$\pm V_S = \pm 5\text{ V}$		$\pm 3.8$			$\pm 3.8$					V	
	$\pm V_S = \pm 16.5\text{ V}$		$\pm 11$			$\pm 11$					V	
	All supply voltages	6.4	8	9.6	6.4	8	9.6	6.4	8	9.6	k $\Omega$	
Maximum Continuous Nondestructive Input			$\pm 12$			$\pm 12$			$\pm 12$		V p-p	
Input Offset Voltage <sup>5</sup>	AC coupled			$\pm 3$			$\pm 3$			$\pm 3$	mV	
Over the Rated Operating Temperature Range			8	30		8	30		8	30	$\mu\text{V}/^\circ\text{C}$	
Vs. Supply	$V_S = \pm 2.5\text{ V to } \pm 5\text{ V}$		80			80			80		$\mu\text{V}/\text{V}$	
	$V_S = \pm 5\text{ V to } \pm 16.5\text{ V}$		50	150		50	150				$\mu\text{V}/\text{V}$	
OUTPUT CHARACTERISTICS		No load										
Output Voltage Swing	$\pm V_S = +2.8\text{ V}/-3.2\text{ V}$	-1.6	-1.7		-1.6	-1.7						V
	$\pm V_S = \pm 5\text{ V}$	-3.3	-3.4		-3.3	-3.4						V
	$\pm V_S = \pm 16.5\text{ V}$	-4	-5		-4	-5						V
	$\pm V_S = \pm 2.5\text{ V}$ , input to Pin 1							-1.1	-0.9			V
Output Resistance	DC	6.4	8	9.6	6.4	8	9.6	6.4	8	9.6	k $\Omega$	
FREQUENCY RESPONSE												
High-Z Input (Pin 2) 1% Additional Error	$V_{IN} = 1\text{ mV rms}$		1			1			1			kHz
	$V_{IN} = 10\text{ mV rms}$		6			6			6			kHz
	$V_{IN} = 100\text{ mV rms}$		37			37			37			kHz
	$V_{IN} = 200\text{ mV rms}$		33			33			33			kHz

Parameter	Conditions	AD737A, AD737J			AD737B, AD737K			AD737J-5			Unit
		Min	Typ	Max	Min	Typ	Max	Min	Typ	Max	
3 dB Bandwidth	$V_{IN} = 1 \text{ mV rms}$		5		5		5		5		kHz
	$V_{IN} = 10 \text{ mV rms}$		55		55		55		55		kHz
	$V_{IN} = 100 \text{ mV rms}$		170		170		170		170		kHz
	$V_{IN} = 200 \text{ mV rms}$		190		190		190		190		kHz
Low-Z Input (Pin 1) 1% Additional Error	$V_{IN} = 1 \text{ mV rms}$		1		1		1		1		kHz
	$V_{IN} = 10 \text{ mV rms}$		6		6		6		6		kHz
	$V_{IN} = 40 \text{ mV rms}$						25		25		kHz
	$V_{IN} = 100 \text{ mV rms}$		90		90		90		90		kHz
	$V_{IN} = 200 \text{ mV rms}$		90		90		90		90		kHz
3 dB Bandwidth	$V_{IN} = 1 \text{ mV rms}$		5		5		5		5		kHz
	$V_{IN} = 10 \text{ mV rms}$		55		55		55		55		kHz
	$V_{IN} = 100 \text{ mV rms}$		350		350		350		350		kHz
	$V_{IN} = 200 \text{ mV rms}$		460		460		460		460		kHz
POWER-DOWN MODE											
Disable Voltage			0		0						V
Input Current, PD Enabled	$V_{PD} = V_S$		11		11						$\mu\text{A}$
POWER SUPPLY											
Operating Voltage Range		+2.8/-3.2	$\pm 5$	$\pm 16.5$	+2.8/-3.2	$\pm 5$	$\pm 16.5$	$\pm 2.5$	$\pm 5$	$\pm 16.5$	V
Current	No input		120	<b>160</b>	120	<b>160</b>		120	<b>160</b>		$\mu\text{A}$
	Rated input		170	210	170	210		170	210		$\mu\text{A}$
	Powered down		25	40	25	40		25	40		$\mu\text{A}$

<sup>1</sup> POR = % of reading.

<sup>2</sup> Nonlinearity is defined as the maximum deviation (in percent error) from a straight line connecting the readings at 0 V and at 200 mV rms.

<sup>3</sup> After fourth-order error correction using the equation

$$y = -0.31009x^4 - 0.21692x^3 - 0.06939x^2 + 0.99756x + 11.1 \times 10^{-6}$$

where y is the corrected result and x is the device output between 0.01 V and 0.3 V.

<sup>4</sup> Crest factor error is specified as the additional error resulting from the specific crest factor, using a 200 mV rms signal as a reference. The crest factor is defined as  $V_{PEAK}/V_{RMS}$ .

<sup>5</sup> DC offset does not limit ac resolution.

## ABSOLUTE MAXIMUM RATINGS

Table 2.

Parameter	Rating
Supply Voltage	$\pm 16.5$ V
Internal Power Dissipation	200 mW
Input Voltage	$\pm V_S$
Output Short-Circuit Duration	Indefinite
Differential Input Voltage	$+V_S$ and $-V_S$
Storage Temperature Range	
CERDIP (Q-8)	$-65^{\circ}\text{C}$ to $+150^{\circ}\text{C}$
PDIP (N-8) and SOIC_N (R-8)	$-65^{\circ}\text{C}$ to $+125^{\circ}\text{C}$
Lead Temperature Range, Soldering (60 sec)	$300^{\circ}\text{C}$
ESD Rating	500 V

Stresses above those listed under Absolute Maximum Ratings may cause permanent damage to the device. This is a stress rating only; functional operation of the device at these or any other conditions above those indicated in the operational section of this specification is not implied. Exposure to absolute maximum rating conditions for extended periods may affect device reliability.

## THERMAL RESISTANCE

$\theta_{JA}$  is specified for the worst-case conditions, that is, a device soldered in a circuit board for surface-mount packages.

Table 3. Thermal Resistance

Package Type	$\theta_{JA}$	Unit
8-Lead CERDIP (Q-8)	110	$^{\circ}\text{C}/\text{W}$
8-Lead PDIP (N-8)	165	$^{\circ}\text{C}/\text{W}$
8-Lead SOIC_N (R-8)	155	$^{\circ}\text{C}/\text{W}$

## ESD CAUTION



**ESD (electrostatic discharge) sensitive device.** Charged devices and circuit boards can discharge without detection. Although this product features patented or proprietary protection circuitry, damage may occur on devices subjected to high energy ESD. Therefore, proper ESD precautions should be taken to avoid performance degradation or loss of functionality.

## PIN CONFIGURATIONS AND FUNCTION DESCRIPTIONS

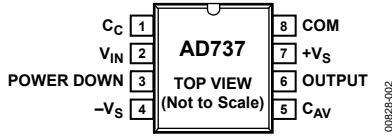

Figure 2. SOIC\_N Pin Configuration (R-8)

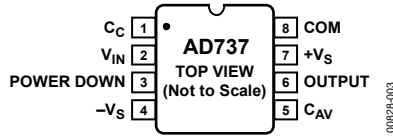

Figure 3. CERDIP Pin Configuration (Q-8)

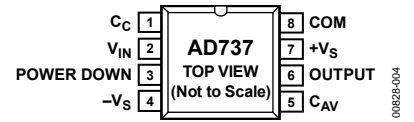

Figure 4. PDIP Pin Configuration (N-8)

**Table 4. Pin Function Descriptions**

Pin No.	Mnemonic	Description
1	C <sub>c</sub>	Coupling Capacitor for Indirect DC Coupling.
2	V <sub>IN</sub>	RMS Input.
3	POWER DOWN	Disables the AD737. Low is enabled; high is powered down.
4	-V <sub>S</sub>	Negative Power Supply.
5	C <sub>AV</sub>	Averaging Capacitor.
6	OUTPUT	Output.
7	+V <sub>S</sub>	Positive Power Supply.
8	COM	Common.

## TYPICAL PERFORMANCE CHARACTERISTICS

$T_A = 25^\circ\text{C}$ ,  $\pm V_S = \pm 5\text{ V}$  (except AD737J-5,  $\pm V_S = \pm 2.5\text{ V}$ ),  $C_{AV} = 33\ \mu\text{F}$ ,  $C_C = 10\ \mu\text{F}$ ,  $f = 1\text{ kHz}$ , sine wave input applied to Pin 2, unless otherwise specified.

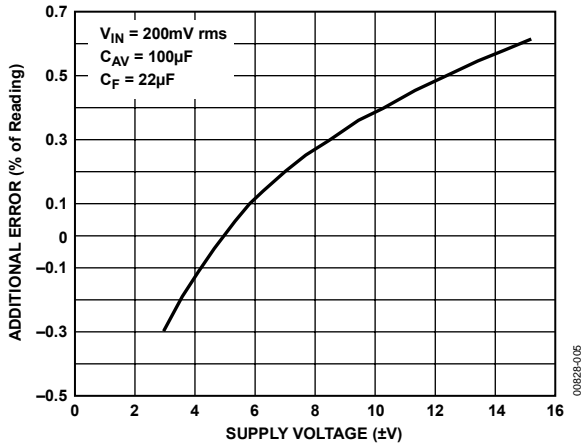

Figure 5. Additional Error vs. Supply Voltage

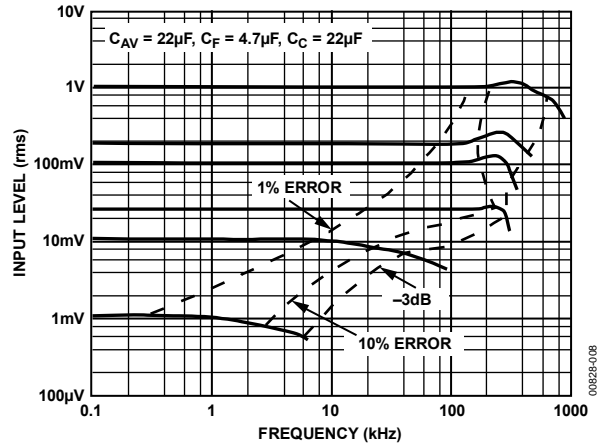

Figure 8. Frequency Response Driving Pin 1

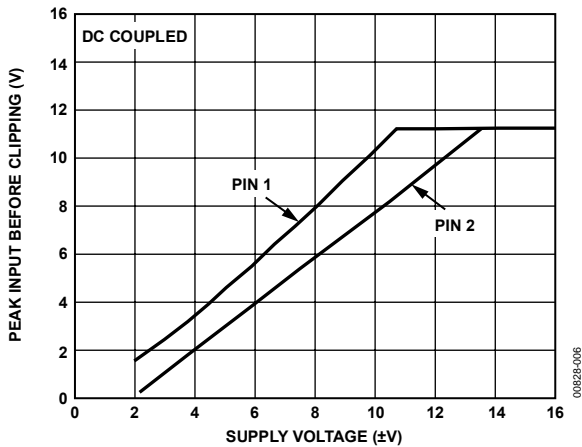

Figure 6. Maximum Input Level vs. Supply Voltage

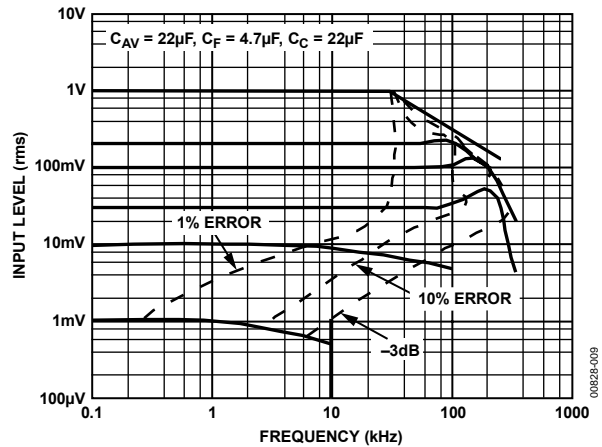

Figure 9. Frequency Response Driving Pin 2

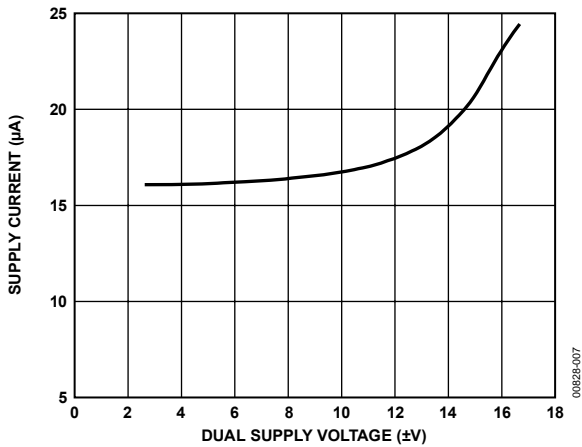

Figure 7. Supply Current (Power-Down Mode) vs. Supply Voltage (Dual)

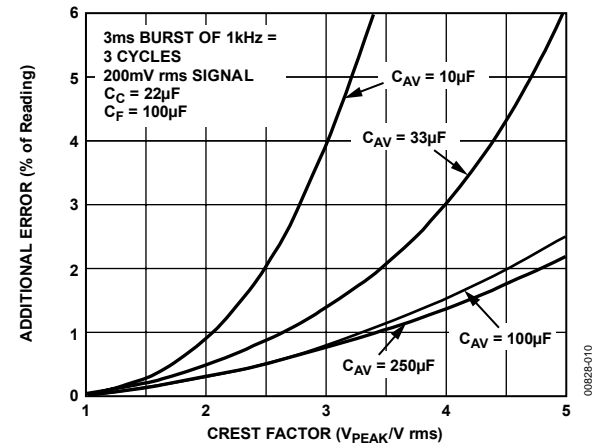

Figure 10. Additional Error vs. Crest Factor



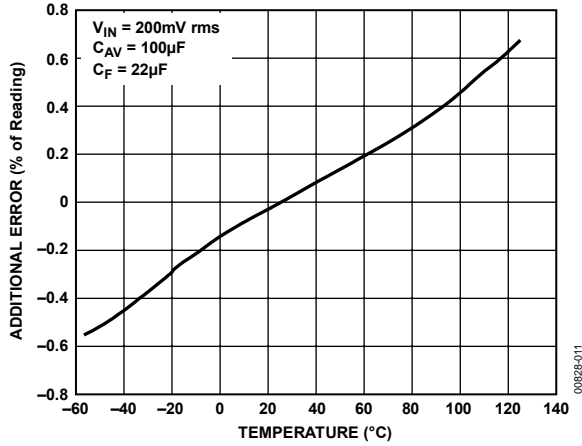

Figure 11. Additional Error vs. Temperature

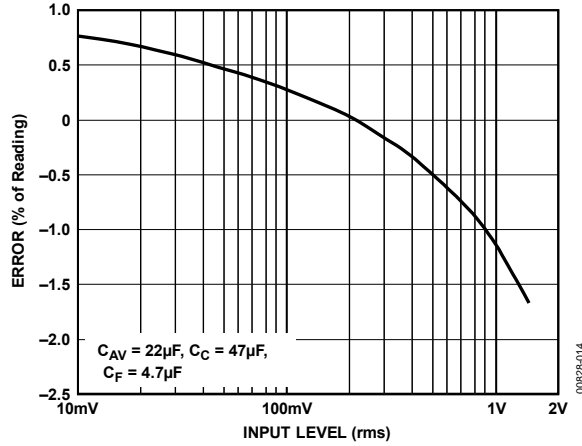

Figure 14. Error vs. RMS Input Level Using Circuit of Figure 29

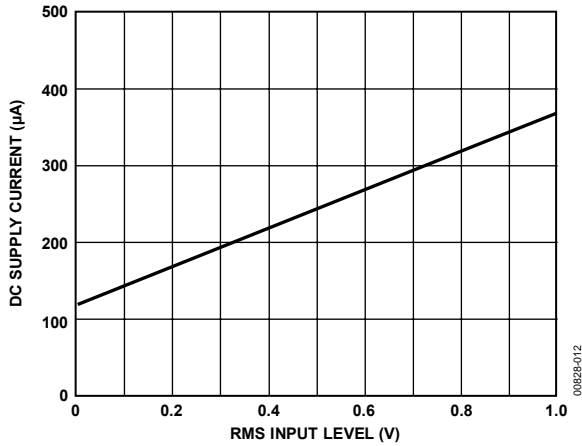

Figure 12. DC Supply Current vs. RMS Input Level

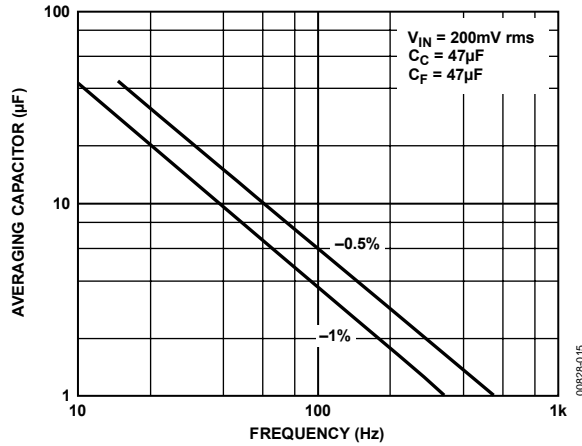

Figure 15. Value of Averaging Capacitor vs. Frequency for Specified Averaging Error

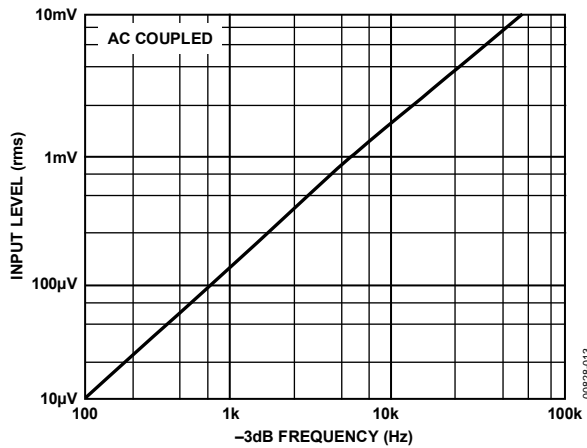

Figure 13. RMS Input Level vs. -3 dB Frequency

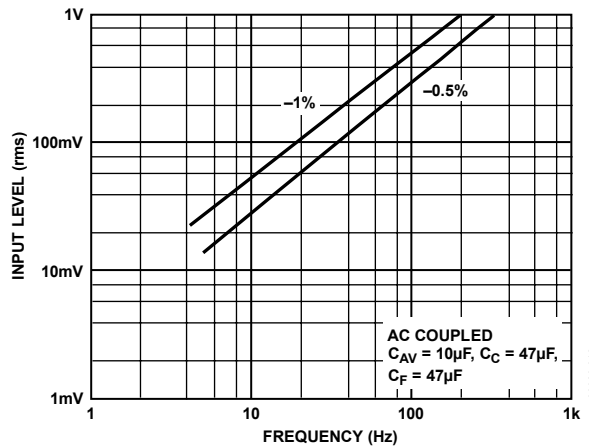

Figure 16. RMS Input Level vs. Frequency for Specified Averaging Error

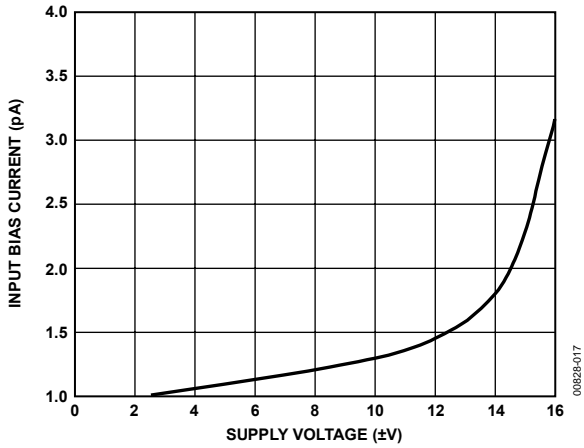

Figure 17. Input Bias Current vs. Supply Voltage

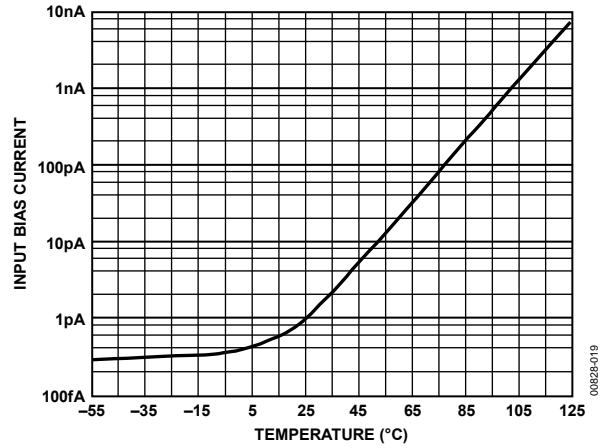

Figure 19. Input Bias Current vs. Temperature

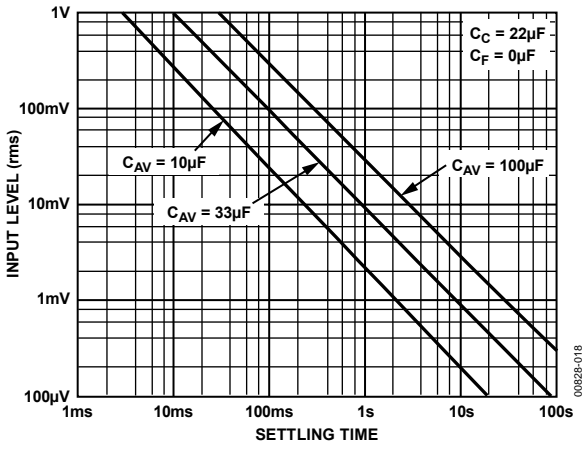

Figure 18. RMS Input Level vs. Settling Time for Three Values of  $C_{AV}$

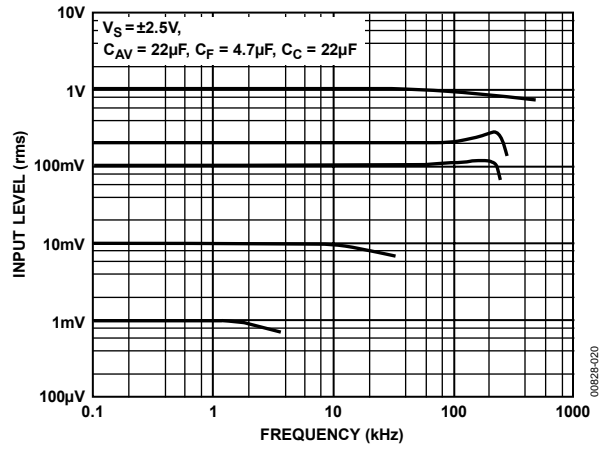

Figure 20. Frequency Response Driving Pin 1

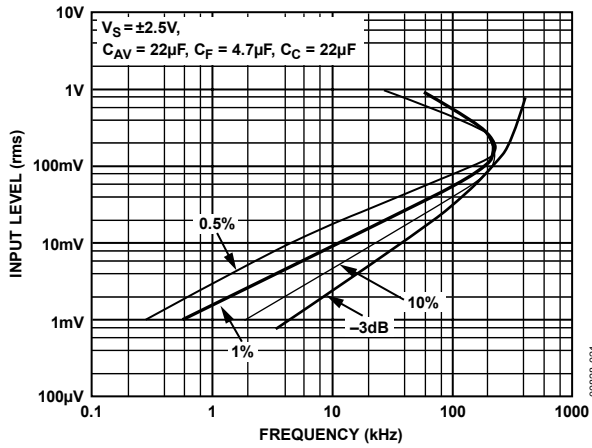

Figure 21. Error Contours Driving Pin 1

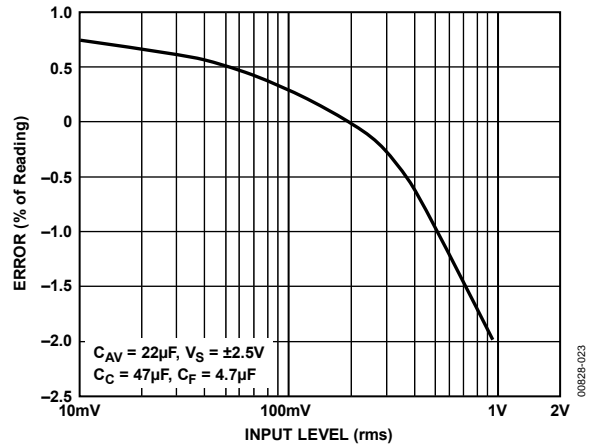

Figure 23. Error vs. RMS Input Level Driving Pin 1

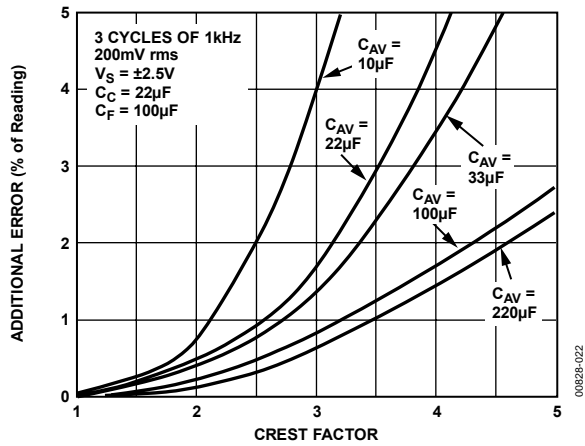

Figure 22. Additional Error vs. Crest Factor for Various Values of  $C_{AV}$

## THEORY OF OPERATION

As shown in Figure 24, the AD737 has four functional subsections: an input amplifier, a full-wave rectifier, an rms core, and a bias section. The FET input amplifier allows a high impedance, buffered input at Pin 2 or a low impedance, wide dynamic range input at Pin 1. The high impedance input, with its low input bias current, is ideal for use with high impedance input attenuators. The input signal can be either dc coupled or ac coupled to the input amplifier. Unlike other rms converters, the AD737 permits both direct and indirect ac coupling of the inputs. AC coupling is provided by placing a series capacitor between the input signal and Pin 2 (or Pin 1) for direct coupling and between Pin 1 and ground (while driving Pin 2) for indirect coupling.

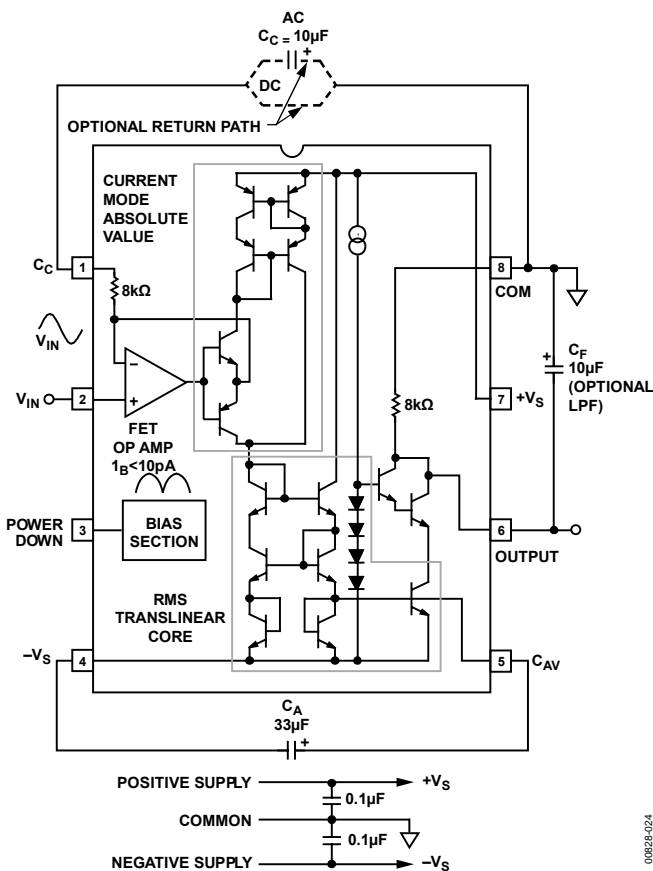

Figure 24. AD737 True RMS Circuit (Test Circuit)

The output of the input amplifier drives a full-wave precision rectifier, which, in turn, drives the rms core. It is the core that provides the essential rms operations of squaring, averaging, and square rooting, using an external averaging capacitor,  $C_{AV}$ .

Without  $C_{AV}$ , the rectified input signal passes through the core unprocessed, as is done with the average responding connection (see Figure 26). In the average responding mode, averaging is carried out by an RC post filter consisting of an 8 k $\Omega$  internal scale factor resistor connected between Pin 6 and Pin 8 and an

external averaging capacitor,  $C_F$ . In the rms circuit, this additional filtering stage reduces any output ripple that was not removed by the averaging capacitor.

Finally, the bias subsection permits a power-down function. This reduces the idle current of the AD737 from 160  $\mu$ A to a mere 30  $\mu$ A. This feature is selected by connecting Pin 3 to Pin 7 (+ $V_S$ ).

## TYPES OF AC MEASUREMENT

The AD737 is capable of measuring ac signals by operating as either an average responding converter or a true rms-to-dc converter. As its name implies, an average responding converter computes the average absolute value of an ac (or ac and dc) voltage or current by full-wave rectifying and low-pass filtering the input signal; this approximates the average. The resulting output, a dc average level, is then scaled by adding (or reducing) gain; this scale factor converts the dc average reading to an rms equivalent value for the waveform being measured. For example, the average absolute value of a sine wave voltage is 0.636 that of  $V_{PEAK}$ ; the corresponding rms value is 0.707 times  $V_{PEAK}$ . Therefore, for sine wave voltages, the required scale factor is 1.11 (0.707 divided by 0.636).

In contrast to measuring the average value, true rms measurement is a universal language among waveforms, allowing the magnitudes of all types of voltage (or current) waveforms to be compared to one another and to dc. RMS is a direct measure of the power or heating value of an ac voltage compared to that of a dc voltage; an ac signal of 1 V rms produces the same amount of heat in a resistor as a 1 V dc signal.

Mathematically, the rms value of a voltage is defined (using a simplified equation) as

$$V_{\text{rms}} = \sqrt{\text{Avg}(V^2)}$$

This involves squaring the signal, taking the average, and then obtaining the square root. True rms converters are smart rectifiers; they provide an accurate rms reading regardless of the type of waveform being measured. However, average responding converters can exhibit very high errors when their input signals deviate from their precalibrated waveform; the magnitude of the error depends on the type of waveform being measured. As an example, if an average responding converter is calibrated to measure the rms value of sine wave voltages and then is used to measure either symmetrical square waves or dc voltages, the converter has a computational error 11% (of reading) higher than the true rms value (see Table 5).

The transfer function for the AD737 is

$$V_{\text{OUT}} = \sqrt{\text{Avg}(V_{\text{IN}}^2)}$$

**DC ERROR, OUTPUT RIPPLE, AND AVERAGING ERROR**

Figure 25 shows the typical output waveform of the AD737 with a sine wave input voltage applied. As with all real-world devices, the ideal output of  $V_{OUT} = V_{IN}$  is never exactly achieved; instead, the output contains both a dc and an ac error component.

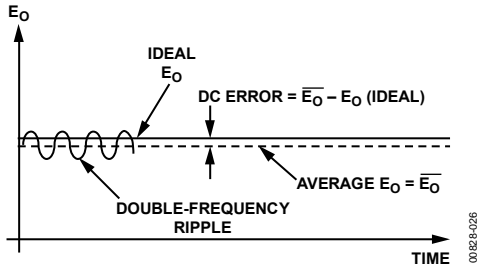

Figure 25. Output Waveform for Sine Wave Input Voltage

As shown, the dc error is the difference between the average of the output signal (when all the ripple in the output has been removed by external filtering) and the ideal dc output. The dc error component is, therefore, set solely by the value of the averaging capacitor used—no amount of post filtering (using a very large postfiltering capacitor,  $C_F$ ) allows the output voltage to equal its ideal value. The ac error component, an output ripple, can be easily removed using a large enough  $C_F$ .

In most cases, the combined magnitudes of the dc and ac error components must be considered when selecting appropriate values for  $C_{AV}$  and  $C_F$  capacitors. This combined error, representing the maximum uncertainty of the measurement, is termed the averaging error and is equal to the peak value of the output ripple plus the dc error. As the input frequency increases, both error components decrease rapidly. If the input frequency doubles, the dc error and ripple reduce to one-quarter and one-half of their original values, respectively, and rapidly become insignificant.

**AC MEASUREMENT ACCURACY AND CREST FACTOR**

The crest factor of the input waveform is often overlooked when determining the accuracy of an ac measurement. Crest factor is defined as the ratio of the peak signal amplitude to the rms amplitude (crest factor =  $V_{PEAK}/V_{rms}$ ). Many common waveforms, such as sine and triangle waves, have relatively low crest factors ( $\geq 2$ ). Other waveforms, such as low duty cycle pulse trains and SCR waveforms, have high crest factors. These types of waveforms require a long averaging time constant to average out the long time periods between pulses. Figure 10 shows the additional error vs. the crest factor of the AD737 for various values of  $C_{AV}$ .

**CALCULATING SETTLING TIME**

Figure 18 can be used to closely approximate the time required for the AD737 to settle when its input level is reduced in amplitude. The net time required for the rms converter to settle is the difference between two times extracted from the graph: the initial time minus the final settling time. As an example, consider the following conditions: a 33  $\mu F$  averaging capacitor, an initial rms input level of 100 mV, and a final (reduced) input level of 1 mV. From Figure 18, the initial settling time (where the 100 mV line intersects the 33  $\mu F$  line) is approximately 80 ms. The settling time corresponding to the new or final input level of 1 mV is approximately 8 seconds. Therefore, the net time for the circuit to settle to its new value is 8 seconds minus 80 ms, which is 7.92 seconds.

Note, because of the smooth decay characteristic inherent with a capacitor/diode combination, this is the total settling time to the final value (not the settling time to 1%, 0.1%, and so on, of the final value). Also, this graph provides the worst-case settling time, because the AD737 settles very quickly with increasing input levels.

**Table 5. Error Introduced by an Average Responding Circuit When Measuring Common Waveforms**

Type of Waveform 1 V Peak Amplitude	Crest Factor ( $V_{PEAK}/V_{rms}$ )	True RMS Value (V)	Reading of an Average Responding Circuit Calibrated to an RMS Sine Wave Value (V)	Error (%)
Undistorted Sine Wave	1.414	0.707	0.707	0
Symmetrical Square Wave	1.00	1.00	1.11	11.0
Undistorted Triangle Wave	1.73	0.577	0.555	-3.8
Gaussian Noise (98% of Peaks <1 V)	3	0.333	0.295	-11.4
Rectangular	2	0.5	0.278	-44
Pulse Train	10	0.1	0.011	-89
SCR Waveforms				
50% Duty Cycle	2	0.495	0.354	-28
25% Duty Cycle	4.7	0.212	0.150	-30

## APPLICATIONS

### RMS MEASUREMENT—CHOOSING OPTIMUM VALUE FOR $C_{AV}$

Because the external averaging capacitor,  $C_{AV}$ , holds the rectified input signal during rms computation, its value directly affects the accuracy of the rms measurement, especially at low frequencies. Furthermore, because the averaging capacitor appears across a diode in the rms core, the averaging time constant increases exponentially as the input signal is reduced. This means that as the input level decreases, errors due to nonideal averaging decrease, while the time it takes for the circuit to settle to the new rms level increases. Therefore, lower input levels allow the circuit to perform better (due to increased averaging) but increase the waiting time between measurements. When selecting  $C_{AV}$ , a trade-off between computational accuracy and settling time is required.

### RAPID SETTling TIMES VIA THE AVERAGE RESPONDING CONNECTION

Because the average responding connection shown in Figure 26 does not use an averaging capacitor, its settling time does not vary with input signal level; it is determined solely by the RC time constant of  $C_F$  and the internal 8 k $\Omega$  output scaling resistor.

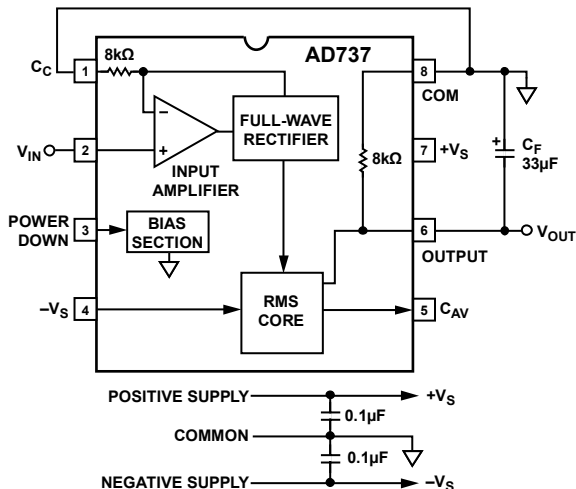

Figure 26. AD737 Average Responding Circuit

### SELECTING PRACTICAL VALUES FOR CAPACITORS

Table 6 provides practical values of  $C_{AV}$  and  $C_F$  for several common applications.

The input coupling capacitor,  $C_C$ , in conjunction with the 8 k $\Omega$  internal input scaling resistor, determines the  $-3$  dB low frequency roll-off. This frequency,  $F_L$ , is equal to

$$F_L = \frac{1}{2\pi \times 8000 \times C_C \text{ (in Farads)}} \quad (1)$$

Note that at  $F_L$ , the amplitude error is approximately  $-30\%$  ( $-3$  dB) of reading. To reduce this error to  $0.5\%$  of reading, choose a value of  $C_C$  that sets  $F_L$  at one-tenth of the lowest frequency to be measured.

In addition, if the input voltage has more than 100 mV of dc offset, the ac coupling network at Pin 2 is required in addition to Capacitor  $C_C$ .

### SCALING INPUT AND OUTPUT VOLTAGES

The AD737 is an extremely flexible device. With minimal external circuitry, it can be powered with single- or dual-polarity power supplies, and input and output voltages are independently scaleable to accommodate nonmatching I/O devices. This section describes a few such applications.

#### Extending or Scaling the Input Range

For low supply voltage applications, the maximum peak voltage to the device is extended by simply applying the input voltage to Pin 1 across the internal 8 k $\Omega$  input resistor. The AD737 input circuit functions quasi differentially, with a high impedance, FET input at Pin 2 (noninverting) and a low impedance input at Pin 1 (inverting, see Figure 26). The internal 8 k $\Omega$  resistor behaves as a voltage-to-current converter connected to the summing node of a feedback loop around the input amplifier. Because the feedback loop servos the summing node voltage to match the voltage at Pin 2, the maximum peak input voltage increases until the internal circuit runs out of headroom, approximately double for a symmetrical dual supply.

#### Battery Operation

All the level-shifting for battery operation is provided by the  $3\frac{1}{2}$  digit converter, shown in Figure 27. Alternatively, an external op amp adds flexibility by accommodating nonzero common-mode voltages and providing output scaling and offset to zero. When an external operational amplifier is used, the output polarity is positive going.

Figure 28 shows an op amp used in a single-supply application. Note the combined input resistor value ( $R_1 + R_2 + 8$  k $\Omega$ ) matches that of the Feedback Resistor  $R_5$ . In this instance, the magnitudes of the output dc voltage and the rms of the ac input are equal.  $R_3$  and  $R_4$  provide current to offset the output to 0 V.

#### Scaling the Output Voltage

The output voltage may be scaled to the input rms voltage. For example, assume the AD737 is retrofitted to an existing application using an averaging responding circuit (full-wave rectifier). The power supply is 12 V; the input voltage is 10 V ac, and the desired output is 6 V dc.

For convenience, use the same combined input resistance as shown in Figure 28. Calculate the rms input current as

$$I_{INMAG} = \frac{10\text{ V}}{69.8\text{ k}\Omega + 2.5\text{ k}\Omega + 8\text{ k}\Omega} = 125\text{ }\mu\text{A} = I_{OUTMAG} \quad (2)$$

Next, using the  $I_{OUTMAG}$  value from Equation 2, calculate the feedback resistor required for 6 V output using

$$R_{FB} = \frac{6\text{ V}}{125\text{ }\mu\text{A}} = 48.1\text{ k}\Omega \quad (3)$$

Select the closest-value standard 1% resistor, 47.5 kΩ.

Since the supply is 12 V, the common-mode voltage at the divider R7/R8 is 6 V, and the combined resistor value (R3 + R4) is equal to the feedback resistor, or 47.5 kΩ.

R2 is used to calibrate the transfer function (gain), and R4 sets the output voltage to zero with no input voltage.

Perform calibration as follows:

1. With no ac input applied, adjust R4 for 0 V.
2. Apply a known input to the input.
3. Adjust trimmer R2 until the input and output match.

The op amp selected for any single-supply application must be a rail-to-rail type, for example an AD8541, shown in Figure 28. For higher voltages, a higher voltage part, such as an OP196, can be used. When calibrating to 0 V, the specified voltage above ground for the operational amplifier must be taken into account. Adjust R4 slightly higher as appropriate.

**Table 6. AD737 Capacitor Selection**

Application	RMS Input Level	Low Frequency Cutoff (−3 dB)	Maximum Crest Factor	C <sub>AV</sub> (μF)	C <sub>F</sub> (μF)	Settling Time <sup>1</sup> to 1%	
General-Purpose RMS Computation	0 V to 1 V	20 Hz	5	150	10	360 ms	
		200 Hz	5	15	1	36 ms	
	0 mV to 200 mV	20 Hz	5	33	10	360 ms	
		200 Hz	5	3.3	1	36 ms	
General-Purpose Average Responding	0 V to 1 V	20 Hz		None	33	1.2 s	
		200 Hz		None	3.3	120 ms	
	0 mV to 200 mV	20 Hz		None	33	1.2 s	
		200 Hz		None	3.3	120 ms	
SCR Waveform Measurement	0 mV to 200 mV	50 Hz	5	100	33	1.2 s	
		60 Hz	5	82	27	1.0 s	
	0 mV to 100 mV	50 Hz	5	50	33	1.2 s	
		60 Hz	5	47	27	1.0 s	
Audio Applications	Speech	0 mV to 200 mV	300 Hz	3	1.5	0.5	18 ms
	Music	0 mV to 100 mV	20 Hz	10	100	68	2.4 s

<sup>1</sup> Settling time is specified over the stated rms input level with the input signal increasing from zero. Settling times are greater for decreasing amplitude input signals.

# AD737

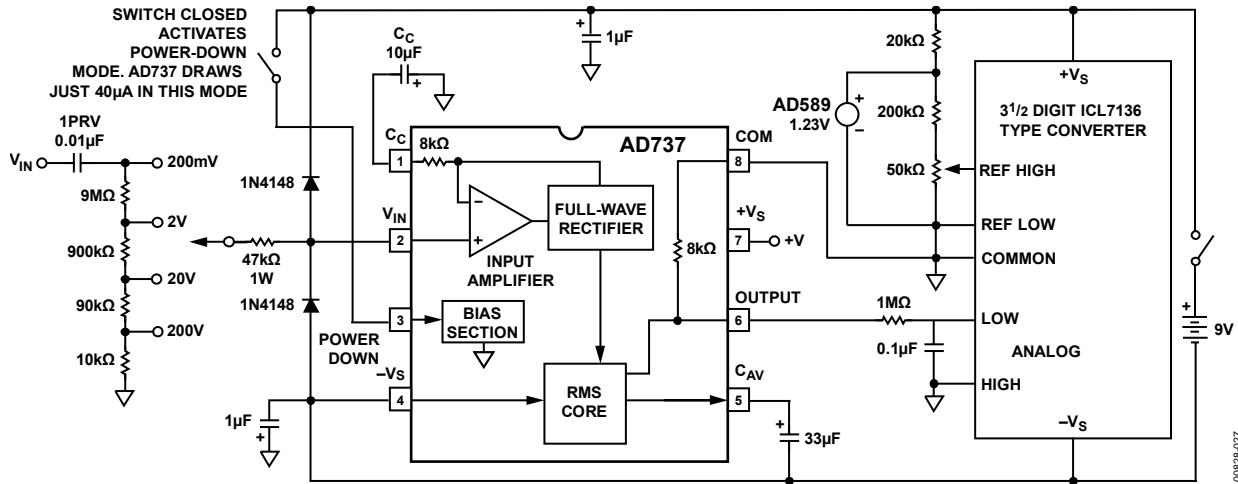

Figure 27. 3 1/2 Digit DVM Circuit

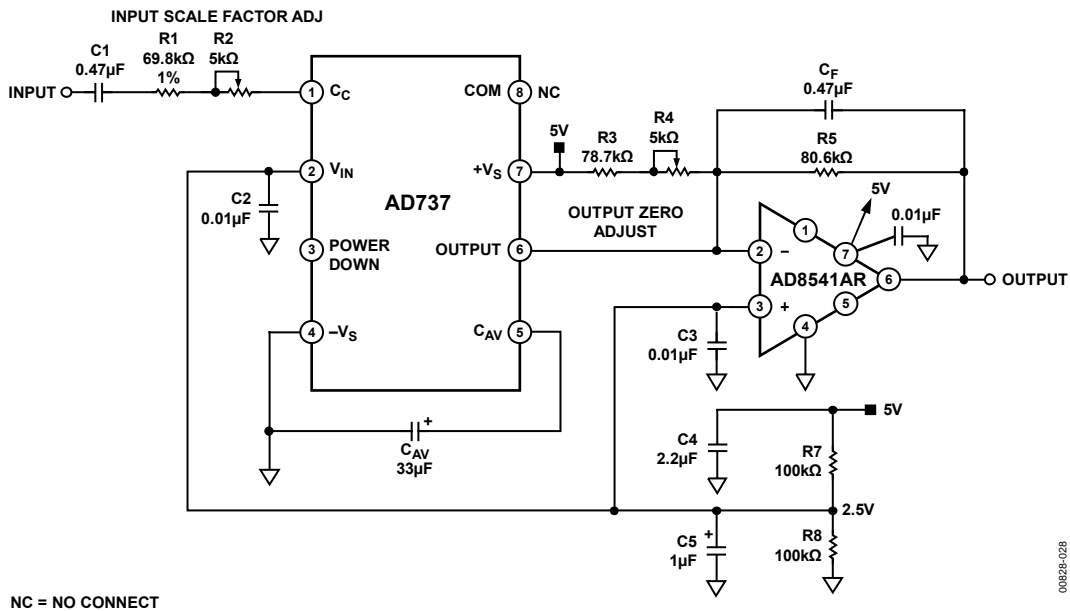

Figure 28. Battery-Powered Operation for 200 mV Maximum RMS Full-Scale Input

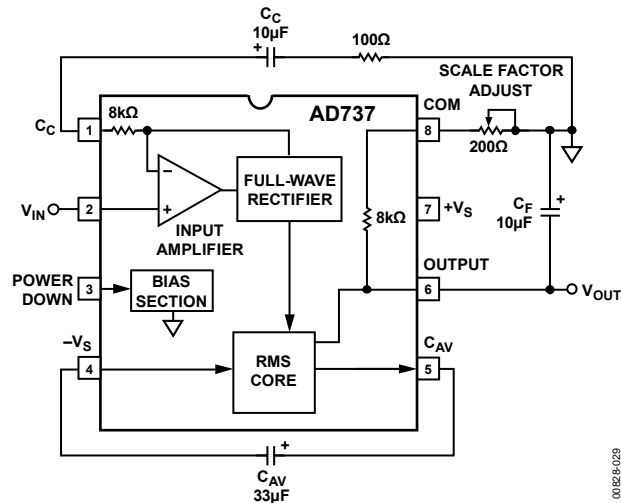
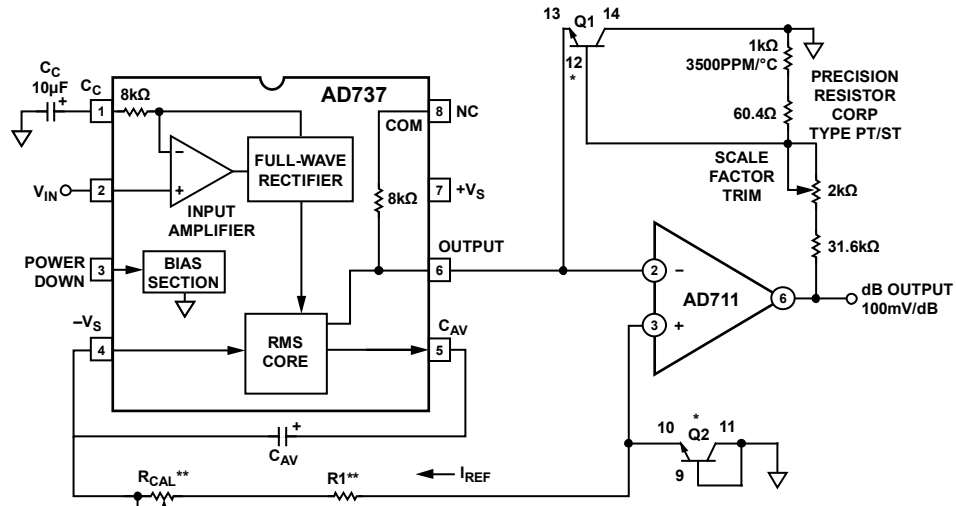

Figure 29. External Scale Factor Trim





NC = NO CONNECT  
 \*Q1, Q2 PART OF RCA CA3046 OR SIMILAR NPN TRANSISTOR ARRAY.  

$$**R1 + R_{CAL} IN \Omega = 10,000 \times \frac{4.3V}{0dB INPUT LEVEL IN V}$$

Figure 30. dB Output Connection

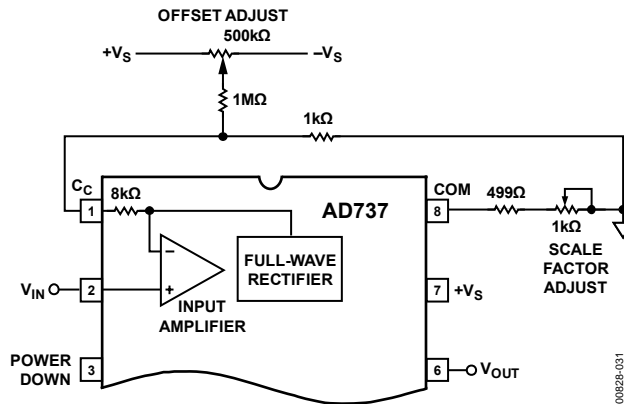

Figure 31. DC-Coupled Offset Voltage and Scale Factor Trims

## AD737 EVALUATION BOARD

An evaluation board, AD737-EVALZ, is available for experimenting or becoming familiar with rms-to-dc converters. Figure 32 is a photograph of the board; Figure 34 to Figure 37 show the signal and power plane copper patterns. The board is designed for multipurpose applications and can be used for the AD736 as well. Although not shipped with the board, an optional socket that accepts the 8-lead surface mount package is available from Enplas Corp.

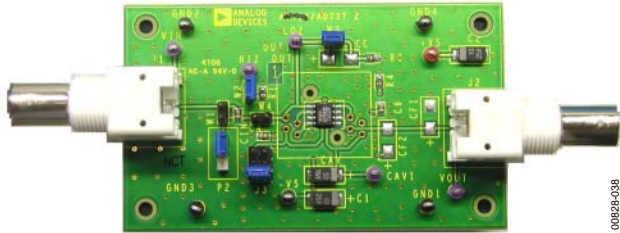

Figure 32. AD737 Evaluation Board

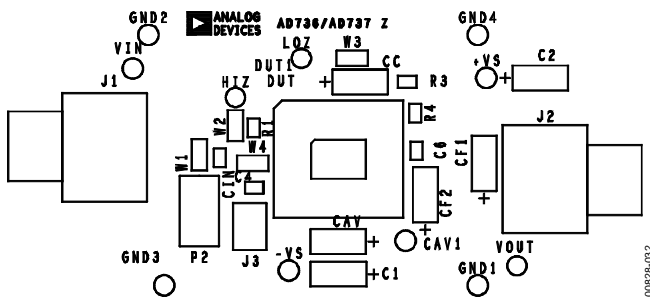

Figure 33. AD737 Evaluation Board—Component-Side Silkscreen

As described in the Applications section, the AD737 may be connected in a variety of ways. As shipped, the board is configured for dual supplies with the high impedance input connected and the power-down feature disabled. Jumpers are provided for connecting the input to the low impedance input (Pin 1) and for dc connections to either input. The schematic with movable jumpers is shown in Figure 38. The jumper positions in black are default connections; the dotted-outline jumpers are optional connections. The board is tested prior to shipment and only requires a power supply connection and a precision meter, to perform measurements. Table 7 provides a bill of materials for the AD737 evaluation board.

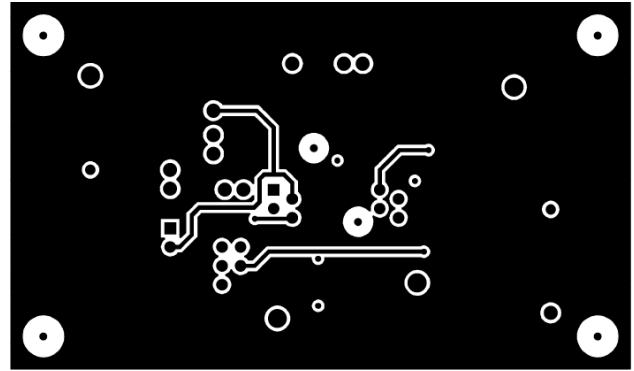

Figure 35. AD737 Evaluation Board—Secondary-Side Copper

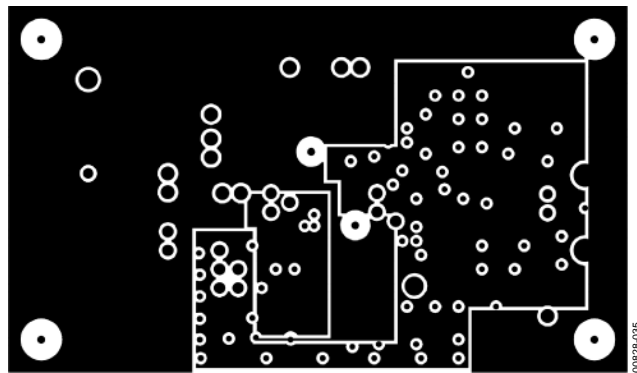

Figure 36. AD737 Evaluation Board—Internal Power Plane

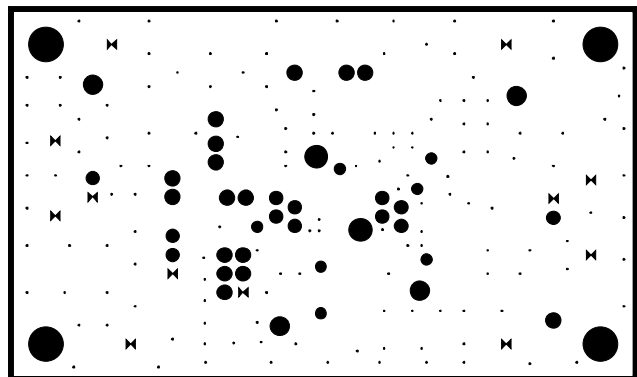

Figure 37. AD737 Evaluation Board—Internal Ground Plane

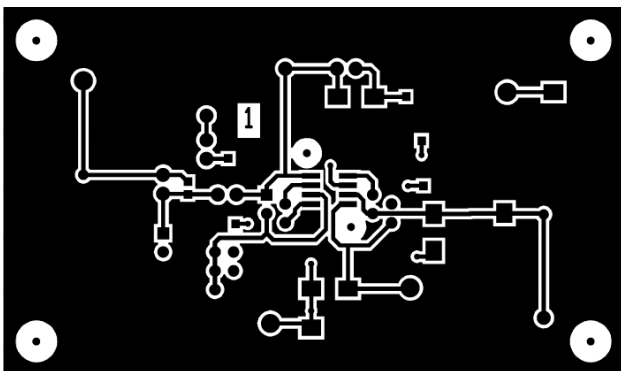

Figure 34. AD737 Evaluation Board—Component-Side Copper

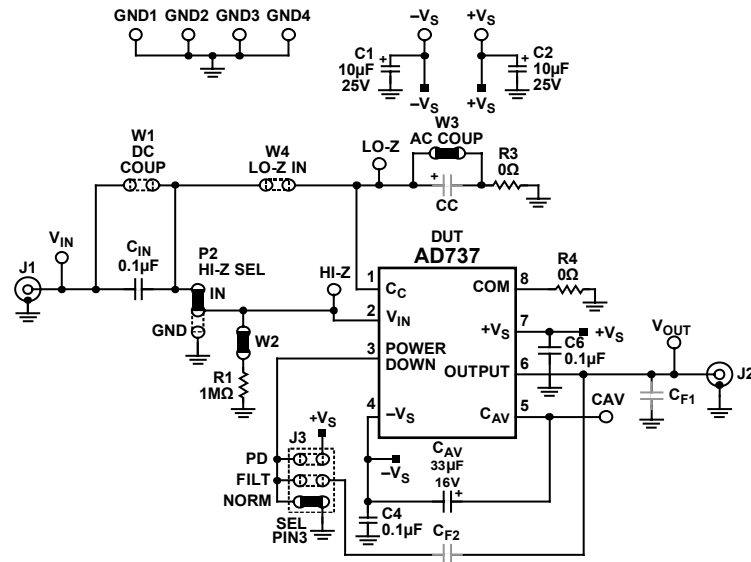
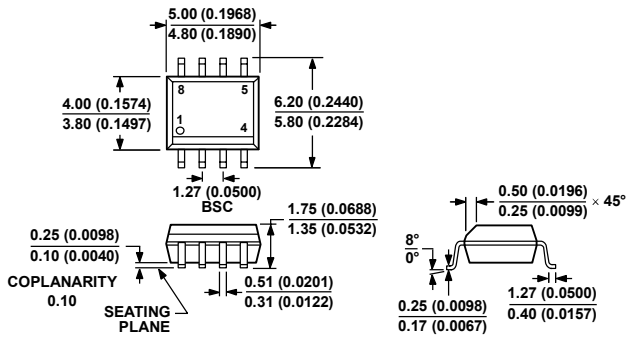

Figure 38. AD737 Evaluation Board Schematic

Table 7. AD737 Evaluation Board Bill of Materials

Qty	Name	Description	Reference Designator	Manufacturer	Mfg. Part Number
1	Test Loop	Red	+VS	Components Corp.	TP-104-01-02
1	Test Loop	Green	-VS	Components Corp.	TP-104-01-05
2	Capacitor	Tantalum 10 µF, 25 V	C1, C2	Nichicon	F931E106MCC
3	Capacitor	0.1 µF, 16 V, 0603, X7R	C4, C6, C <sub>IN</sub>	KEMET	C0603C104K4RACTU
1	Capacitor	Tantalum 33 µF, 16V, 20%, 6032	CAV	Nichicon	F931C336MCC
5	Test Loop	Purple	C <sub>AV</sub> , HI-Z, LO-Z, V <sub>IN</sub> , V <sub>OUT</sub>	Components Corp.	TP-104-01-07
1	Integrated Circuit	RMS-to-DC converter	DUT	Analog Devices, Inc.	AD737JRZ
4	Test Loop	Black	GND1, GND2, GND3, GND4	Components Corp.	TP-104-01-00
2	Connector	BNC, right angle	J1, J2	AMP	227161-1
1	Header	6 Pins, 2 × 3	J3	3M	929836-09-03
1	Header	3 Pins	P2	Molex	22-10-2031
1	Resistor	1 MΩ, 1/10 W, 1%, 0603	R1	Panasonic	ERJ3EKF1004V
2	Resistor	0 Ω, 5%, 0603	R3, R4	Panasonic	ERJ3GEY0R00V
4	Header	2 Pins, 0.1" center	W1, W2, W3, W4	Molex	22-10-2021

OUTLINE DIMENSIONS



COMPLIANT TO JEDEC STANDARDS MS-012-AA

CONTROLLING DIMENSIONS ARE IN MILLIMETERS; INCH DIMENSIONS (IN PARENTHESES) ARE ROUNDED-OFF MILLIMETER EQUIVALENTS FOR REFERENCE ONLY AND ARE NOT APPROPRIATE FOR USE IN DESIGN.

Figure 39. 8-Lead Standard Small Outline Package [SOIC\_N] Narrow Body (R-8)  
Dimensions shown in millimeters and (inches)

060606-A

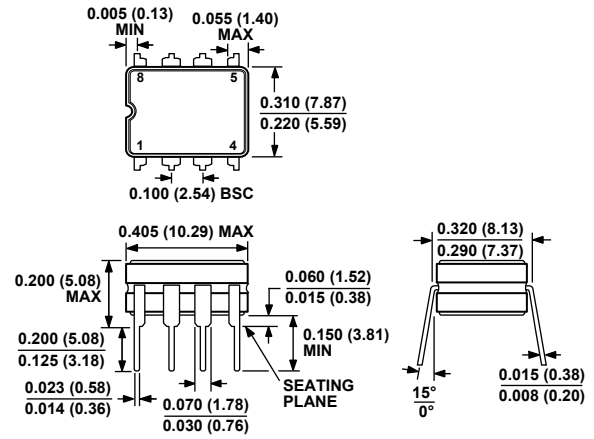

CONTROLLING DIMENSIONS ARE IN INCHES; MILLIMETER DIMENSIONS (IN PARENTHESES) ARE ROUNDED-OFF INCH EQUIVALENTS FOR REFERENCE ONLY AND ARE NOT APPROPRIATE FOR USE IN DESIGN.

Figure 40. 8-Lead Ceramic Dual In-Line Package [CERDIP] (Q-8)  
Dimensions shown in inches and (millimeters)

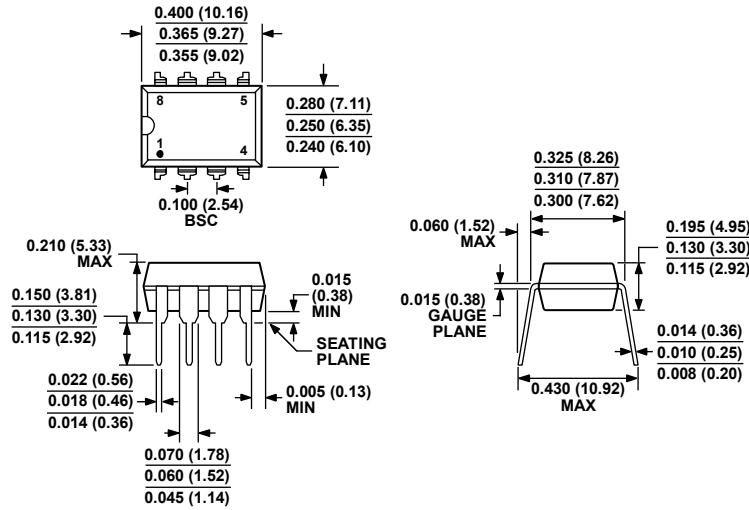

COMPLIANT TO JEDEC STANDARDS MS-001

CONTROLLING DIMENSIONS ARE IN INCHES; MILLIMETER DIMENSIONS (IN PARENTHESES) ARE ROUNDED-OFF INCH EQUIVALENTS FOR REFERENCE ONLY AND ARE NOT APPROPRIATE FOR USE IN DESIGN. CORNER LEADS MAY BE CONFIGURED AS WHOLE OR HALF LEADS.

Figure 41. 8-Lead Plastic Dual-In-Line Package [PDIP] (N-8)  
Dimensions shown in inches and (millimeters)

070606-A

## ORDERING GUIDE

Model	Temperature Range	Package Description	Package Option
AD737AN	−40°C to +85°C	8-Lead Plastic Dual In-Line Package [PDIP]	N-8
AD737ANZ <sup>1</sup>	−40°C to +85°C	8-Lead Plastic Dual In-Line Package [PDIP]	N-8
AD737AQ	−40°C to +85°C	8-Lead Ceramic Dual In-Line Package [CERDIP]	Q-8
AD737AR	−40°C to +85°C	8-Lead Standard Small Outline Package [SOIC_N]	R-8
AD737ARZ <sup>1</sup>	−40°C to +85°C	8-Lead Standard Small Outline Package [SOIC_N]	R-8
AD737BQ	−40°C to +85°C	8-Lead Ceramic Dual In-Line Package [CERDIP]	Q-8
AD737JN	0°C to 70°C	8-Lead Plastic Dual In-Line Package [PDIP]	N-8
AD737JNZ <sup>1</sup>	0°C to 70°C	8-Lead Plastic Dual In-Line Package [PDIP]	N-8
AD737JR	0°C to 70°C	8-Lead Standard Small Outline Package [SOIC_N]	R-8
AD737JR-REEL	0°C to 70°C	8-Lead Standard Small Outline Package [SOIC_N]	R-8
AD737JR-REEL7	0°C to 70°C	8-Lead Standard Small Outline Package [SOIC_N]	R-8
AD737JR-5	0°C to 70°C	8-Lead Standard Small Outline Package [SOIC_N]	R-8
AD737JR-5-REEL	0°C to 70°C	8-Lead Standard Small Outline Package [SOIC_N]	R-8
AD737JR-5-REEL7	0°C to 70°C	8-Lead Standard Small Outline Package [SOIC_N]	R-8
AD737JRZ <sup>1</sup>	0°C to 70°C	8-Lead Standard Small Outline Package [SOIC_N]	R-8
AD737JRZ-R7 <sup>1</sup>	0°C to 70°C	8-Lead Standard Small Outline Package [SOIC_N]	R-8
AD737JRZ-RL <sup>1</sup>	0°C to 70°C	8-Lead Standard Small Outline Package [SOIC_N]	R-8
AD737JRZ-5 <sup>1</sup>	0°C to 70°C	8-Lead Standard Small Outline Package [SOIC_N]	R-8
AD737JRZ-5-R7 <sup>1</sup>	0°C to 70°C	8-Lead Standard Small Outline Package [SOIC_N]	R-8
AD737JRZ-5-RL <sup>1</sup>	0°C to 70°C	8-Lead Standard Small Outline Package [SOIC_N]	R-8
AD737KN	0°C to 70°C	8-Lead Plastic Dual In-Line Package [PDIP]	N-8
AD737KNZ <sup>1</sup>	0°C to 70°C	8-Lead Plastic Dual In-Line Package [PDIP]	N-8
AD737KR	0°C to 70°C	8-Lead Standard Small Outline Package [SOIC_N]	R-8
AD737KR-REEL	0°C to 70°C	8-Lead Standard Small Outline Package [SOIC_N]	R-8
AD737KR-REEL7	0°C to 70°C	8-Lead Standard Small Outline Package [SOIC_N]	R-8
AD737KRZ <sup>1</sup>	0°C to 70°C	8-Lead Standard Small Outline Package [SOIC_N]	R-8
AD737KRZ-RL <sup>1</sup>	0°C to 70°C	8-Lead Standard Small Outline Package [SOIC_N]	R-8
AD737KRZ-R7 <sup>1</sup>	0°C to 70°C	8-Lead Standard Small Outline Package [SOIC_N]	R-8
AD737-EVALZ <sup>1</sup>		Evaluation Board	

<sup>1</sup> Z = Pb-free part.

**AD737**

**NOTES**

**NOTES**

**AD737**

**NOTES**