

### FEATURES

- Low Cost**
- Excellent Video Performance**
  - 55 MHz 0.1 dB Bandwidth (Gain = +2)
  - 0.01% and 0.05° Differential Gain and Phase Errors
- High Speed**
  - 130 MHz Bandwidth (3 dB, G = +2)
  - 100 MHz Bandwidth (3 dB, G+ = -1)
  - 500 V/ $\mu$ s Slew Rate
  - 80 ns Settling Time to 0.01% ( $V_O = 10$  V Step)
- High Output Drive Capability**
  - 50 mA Minimum Output Current
  - Ideal for Driving Back Terminated Cables
- Flexible Power Supply**
  - Specified for Single (+5 V) and Dual ( $\pm 5$  V to  $\pm 15$  V) Power Supplies
  - Low Power: 7.5 mA Max Supply Current
- Available in 8-Lead SOIC and 8-Lead PDIP**

### GENERAL DESCRIPTION

The AD818 is a low cost video op amp optimized for use in video applications that require gains equal to or greater than +2 or -1. The AD818's low differential gain and phase errors, single supply functionality, low power, and high output drive make it ideal for cable driving applications such as video cameras and professional video equipment.

With video specs like 0.1 dB flatness to 55 MHz and low differential gain and phase errors of 0.01% and 0.05°, along with 50 mA of output current, the AD818 is an excellent choice for

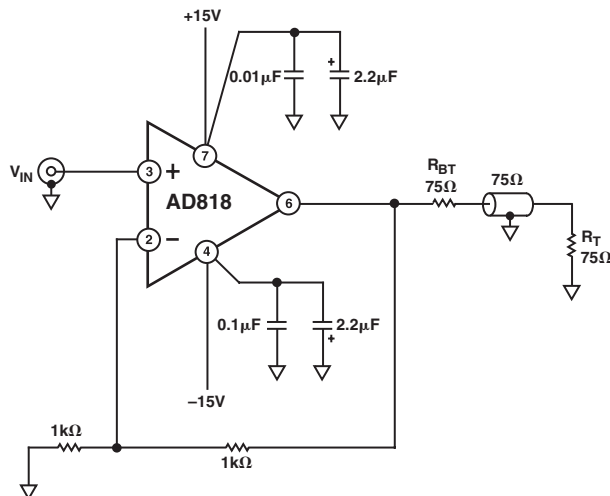

Figure 1. Video Line Driver

REV. C

Information furnished by Analog Devices is believed to be accurate and reliable. However, no responsibility is assumed by Analog Devices for its use, nor for any infringements of patents or other rights of third parties that may result from its use. No license is granted by implication or otherwise under any patent or patent rights of Analog Devices. Trademarks and registered trademarks are the property of their respective companies.

### CONNECTION DIAGRAM

8-Lead Plastic Mini-DIP (N) and SOIC (R) Packages

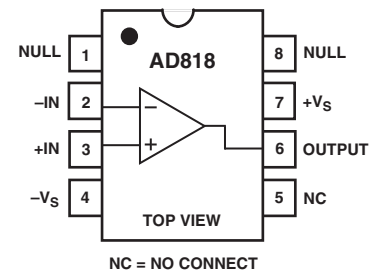

any video application. The 130 MHz 3 dB bandwidth ( $G = +2$ ) and 500 V/ $\mu$ s slew rate make the AD818 useful in many high speed applications including video monitors, CATV, color copiers, image scanners, and fax machines.

The AD818 is fully specified for operation with a single +5 V power supply and with dual supplies from  $\pm 5$  V to  $\pm 15$  V. This power supply flexibility, coupled with a very low supply current of 7.5 mA and excellent ac characteristics under all power supply conditions, make the AD818 the ideal choice for many demanding yet power sensitive applications.

The AD818 is a voltage feedback op amp and excels as a gain stage in high speed and video systems ( $\text{gain} \geq 2$ , or  $\text{gain} \leq -1$ ). It achieves a settling time of 45 ns to 0.1%, with a low input offset voltage of 2 mV max.

The AD818 is available in low cost, small 8-lead PDIP and SOIC packages.

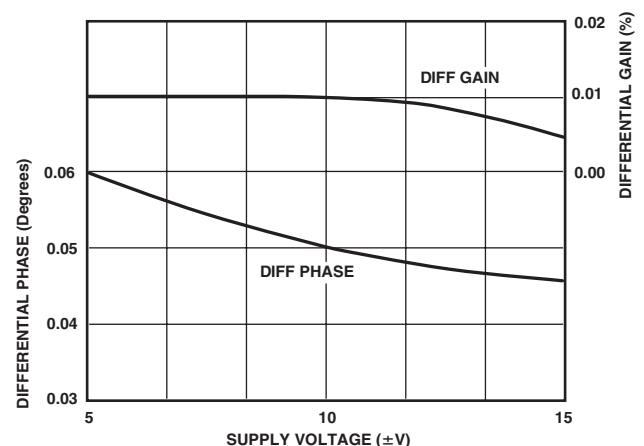

Figure 2. Differential Gain and Phase vs. Supply

# AD818—SPECIFICATIONS

(@  $T_A = 25^\circ\text{C}$ , unless otherwise noted.)

Parameter	Conditions	$V_S$	AD818A			Unit
			Min	Typ	Max	
<b>DYNAMIC PERFORMANCE</b>						
-3 dB Bandwidth	Gain = +2	$\pm 5\text{ V}$	70	95		MHz
		$\pm 15\text{ V}$	100	130		MHz
		0 V, +5 V	40	55		MHz
Bandwidth for 0.1 dB Flatness	Gain = -1	$\pm 5\text{ V}$	50	70		MHz
		$\pm 15\text{ V}$	70	100		MHz
		0 V, +5 V	30	50		MHz
	Gain = +2 $C_C = 2\text{ pF}$	$\pm 5\text{ V}$	20	43		MHz
		$\pm 15\text{ V}$	40	55		MHz
		0 V, +5 V	10	18		MHz
Full Power Bandwidth*	Gain = -1 $C_C = 2\text{ pF}$	$\pm 5\text{ V}$	18	34		MHz
		$\pm 15\text{ V}$	40	72		MHz
		0 V, +5 V	10	19		MHz
	$V_{OUT} = 5\text{ V p-p}$ $R_{LOAD} = 500\ \Omega$ $V_{OUT} = 20\text{ V p-p}$ $R_{LOAD} = 1\text{ k}\Omega$	$\pm 5\text{ V}$		25.5		MHz
		$\pm 15\text{ V}$		8.0		MHz
		0 V, +5 V				
Slew Rate	Gain = -1 $R_{LOAD} = 1\text{ k}\Omega$	$\pm 5\text{ V}$	350	400		V/ $\mu\text{s}$
		$\pm 15\text{ V}$	450	500		V/ $\mu\text{s}$
		0 V, +5 V	250	300		V/ $\mu\text{s}$
Settling Time to 0.1%	-2.5 V to +2.5 V 0 V-10 V Step, $A_V = -1$	$\pm 5\text{ V}$		45		ns
Settling Time to 0.01%	-2.5 V to +2.5 V 0 V-10 V Step, $A_V = -1$	$\pm 15\text{ V}$		45		ns
Total Harmonic Distortion	$F_C = 1\text{ MHz}$	$\pm 15\text{ V}$		80		ns
Differential Gain Error ( $R_L = 150\ \Omega$ )	NTSC Gain = +2	$\pm 15\text{ V}$		0.005	0.01	%
		$\pm 5\text{ V}$		0.01	0.02	%
		0 V, +5 V		0.08		%
Differential Phase Error ( $R_L = 150\ \Omega$ )	NTSC Gain = +2	$\pm 15\text{ V}$		0.045	0.09	Degrees
		$\pm 5\text{ V}$		0.06	0.09	Degrees
		0 V, +5 V		0.1		Degrees
Cap Load Drive				10		pF
<b>INPUT OFFSET VOLTAGE</b>						
Offset Drift	$T_{MIN}$ to $T_{MAX}$	$\pm 5\text{ V}$ to $\pm 15\text{ V}$		0.5	2	mV
					3	mV
<b>INPUT BIAS CURRENT</b>						
	$T_{MIN}$ $T_{MAX}$	$\pm 5\text{ V}$ , $\pm 15\text{ V}$		3.3	6.6	$\mu\text{A}$
					10	$\mu\text{A}$
					4.4	$\mu\text{A}$
<b>INPUT OFFSET CURRENT</b>						
Offset Current Drift	$T_{MIN}$ to $T_{MAX}$	$\pm 5\text{ V}$ , $\pm 15\text{ V}$		25	300	nA
					500	nA
<b>OPEN-LOOP GAIN</b>						
	$V_{OUT} = \pm 2.5\text{ V}$ $R_{LOAD} = 500\ \Omega$ $T_{MIN}$ to $T_{MAX}$ $R_{LOAD} = 150\ \Omega$	$\pm 5\text{ V}$	3	5		V/mV
			2			V/mV
			2	4		V/mV
	$V_{OUT} = \pm 10\text{ V}$ $R_{LOAD} = 1\text{ k}\Omega$ $T_{MIN}$ to $T_{MAX}$	$\pm 15\text{ V}$	6	9		V/mV
			3			V/mV
	$V_{OUT} = \pm 7.5\text{ V}$ $R_{LOAD} = 150\ \Omega$ (50 mA Output)	$\pm 15\text{ V}$	3	5		V/mV
<b>COMMON-MODE REJECTION</b>						
	$V_{CM} = \pm 2.5\text{ V}$ $V_{CM} = \pm 12\text{ V}$ $T_{MIN}$ to $T_{MAX}$	$\pm 5\text{ V}$ $\pm 15\text{ V}$ $\pm 15\text{ V}$	82	100		dB
			86	120		dB
			84	100		dB

Parameter	Conditions	V <sub>S</sub>	AD818A			Unit
			Min	Typ	Max	
POWER SUPPLY REJECTION	V <sub>S</sub> = ±5 V to ±15 V T <sub>MIN</sub> to T <sub>MAX</sub>		80	90		dB
			80			dB
INPUT VOLTAGE NOISE	f = 10 kHz	±5 V, ±15 V		10		nV/√Hz
INPUT CURRENT NOISE	f = 10 kHz	±5 V, ±15 V		1.5		pA/√Hz
INPUT COMMON-MODE VOLTAGE RANGE		±5 V	+3.8	+4.3		V
			-2.7	-3.4		V
			+13	+14.3		V
			-12	-13.4		V
			+3.8	+4.3		V
OUTPUT VOLTAGE SWING	R <sub>LOAD</sub> = 500 Ω R <sub>LOAD</sub> = 150 Ω R <sub>LOAD</sub> = 1 kΩ R <sub>LOAD</sub> = 500 Ω R <sub>LOAD</sub> = 500 Ω	±5 V	3.3	3.8		±V
			3.2	3.6		±V
			13.3	13.7		±V
			12.8	13.4		±V
			1.5, 3.5			V
			50			mA
			50			mA
			30			mA
				90		mA
INPUT RESISTANCE				300		kΩ
INPUT CAPACITANCE				1.5		pF
OUTPUT RESISTANCE	Open Loop			8		Ω
POWER SUPPLY Operating Range	Dual Supply Single Supply		±2.5		±18	V
			+5		+36	V
Quiescent Current	T <sub>MIN</sub> to T <sub>MAX</sub>	±5 V		7.0	7.5	mA
			±5 V		7.5	mA
			±15 V		7.5	mA
			±15 V	7.0	7.5	mA

\*Full power bandwidth = slew rate/(2π V<sub>PEAK</sub>).

Specifications subject to change without notice.

# AD818

## ABSOLUTE MAXIMUM RATINGS<sup>1</sup>

Supply Voltage	±18 V
Internal Power Dissipation <sup>2</sup>	
Plastic (N)	See Derating Curves
Small Outline (R)	See Derating Curves
Input Voltage (Common Mode)	±V <sub>S</sub>
Differential Input Voltage	±6 V
Output Short-Circuit Duration	See Derating Curves
Storage Temperature Range (N, R)	-65°C to +125°C
Operating Temperature Range	-40°C to +85°C
Lead Temperature Range (Soldering 10 sec)	300°C

### NOTES

<sup>1</sup>Stresses above those listed under Absolute Maximum Ratings may cause permanent damage to the device. This is a stress rating only; functional operation of the device at these or any other conditions above those indicated in the operational section of this specification is not implied. Exposure to absolute maximum rating conditions for extended periods may affect device reliability.

<sup>2</sup>Specification is for device in free air: 8-lead plastic package,  $\theta_{JA} = 90^\circ\text{C/W}$ ; 8-lead SOIC package,  $\theta_{JA} = 155^\circ\text{C/W}$ .

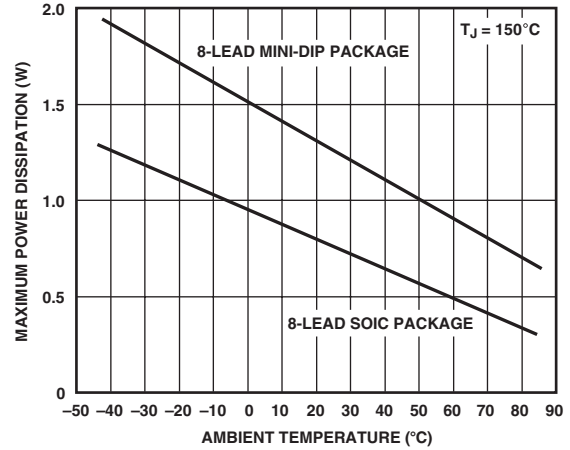

Figure 3. Maximum Power Dissipation vs. Temperature for Different Package Types

## ORDERING GUIDE

Model	Temperature Range	Package Description	Package Option
AD818AN	-40°C to +85°C	8-Lead Plastic PDIP	N-8
AD818AR	-40°C to +85°C	8-Lead Plastic SOIC	R-8
AD818AR-REEL	-40°C to +85°C	13" Tape and Reel	R-8
AD818AR-REEL7	-40°C to +85°C	7" Tape and Reel	R-8

## CAUTION

ESD (electrostatic discharge) sensitive device. Electrostatic charges as high as 4000 V readily accumulate on the human body and test equipment and can discharge without detection. Although the AD818 features proprietary ESD protection circuitry, permanent damage may occur on devices subjected to high energy electrostatic discharges. Therefore, proper ESD precautions are recommended to avoid performance degradation or loss of functionality.



## METALLIZATION PHOTOGRAPH

Dimensions shown in inches and (mm)

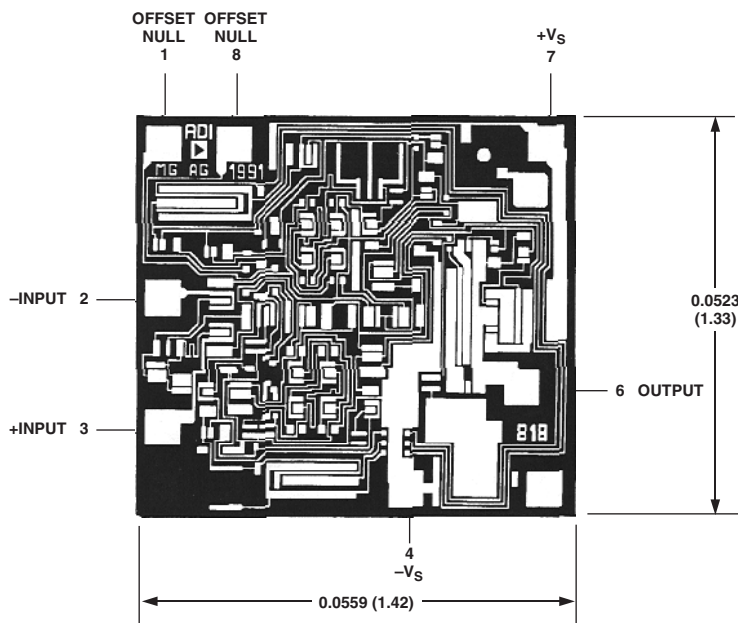

# Typical Performance Characteristics—AD818

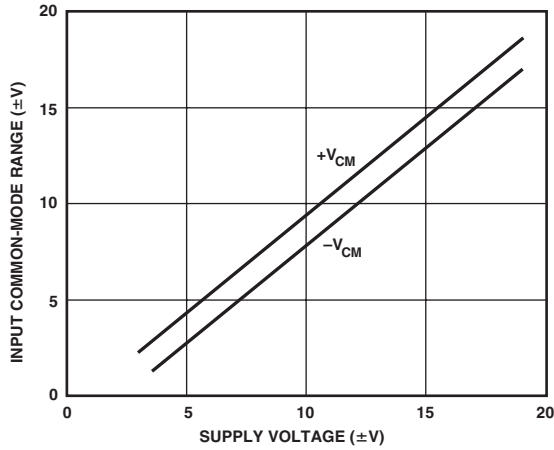

TPC 1. Common-Mode Voltage Range vs. Supply

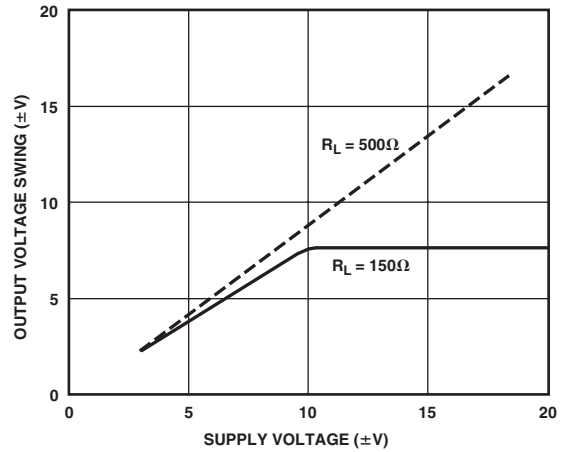

TPC 4. Output Voltage Swing vs. Supply

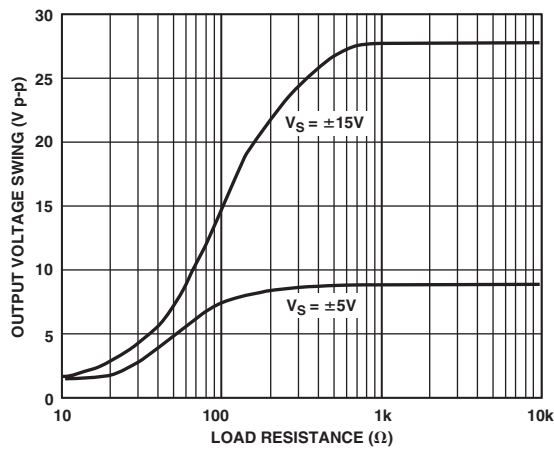

TPC 2. Output Voltage Swing vs. Load Resistance

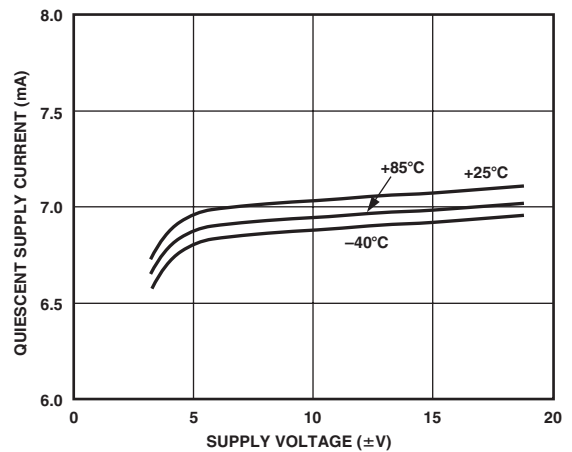

TPC 5. Quiescent Supply Current vs. Supply Voltage

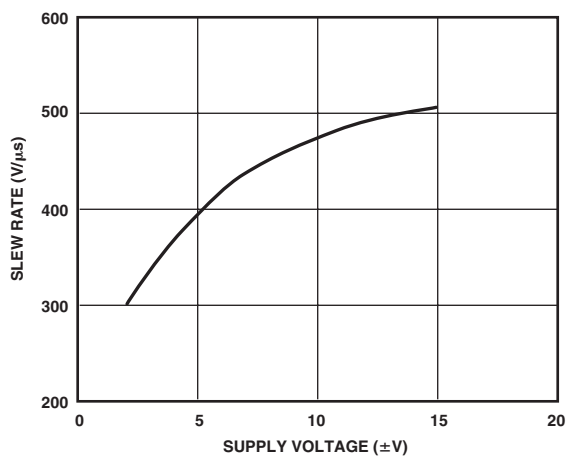

TPC 3. Slew Rate vs. Supply Voltage

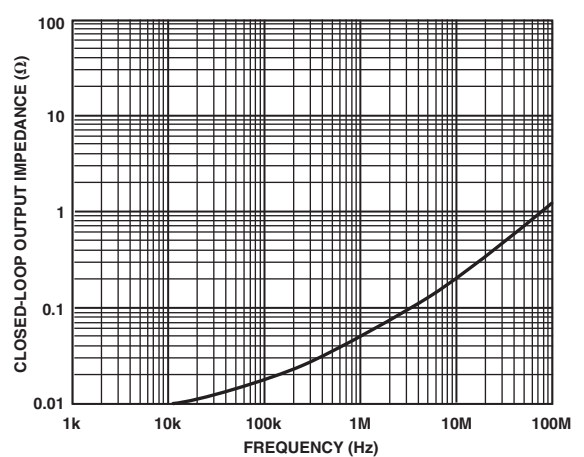

TPC 6. Closed-Loop Output Impedance vs. Frequency

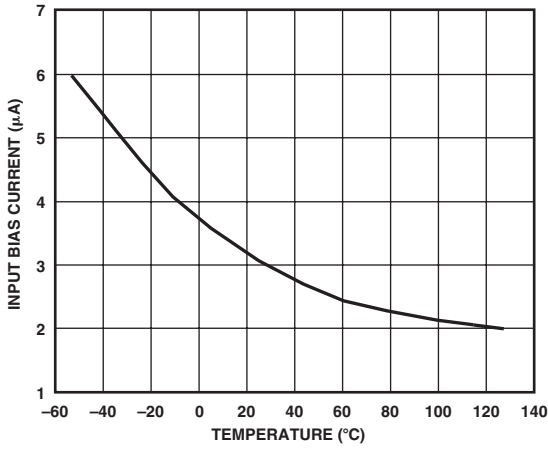

TPC 7. Input Bias Current vs. Temperature

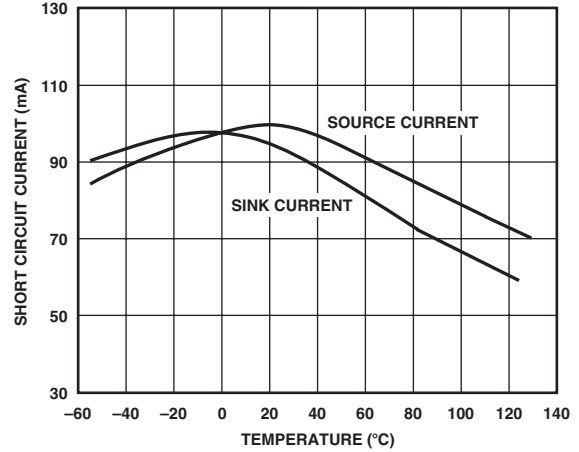

TPC 10. Short-Circuit Current vs. Temperature

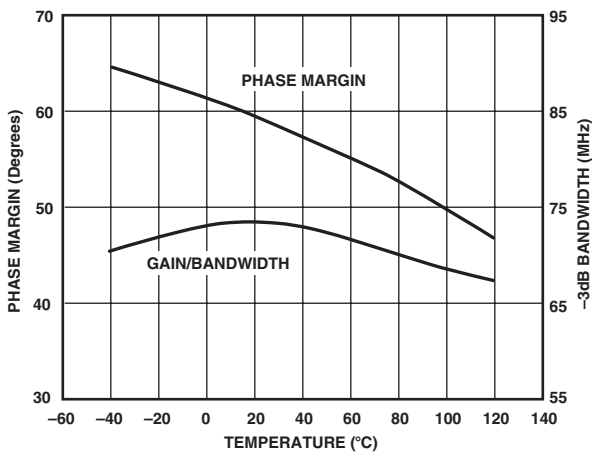

TPC 8. -3 dB Bandwidth and Phase Margin vs. Temperature, Gain = +2

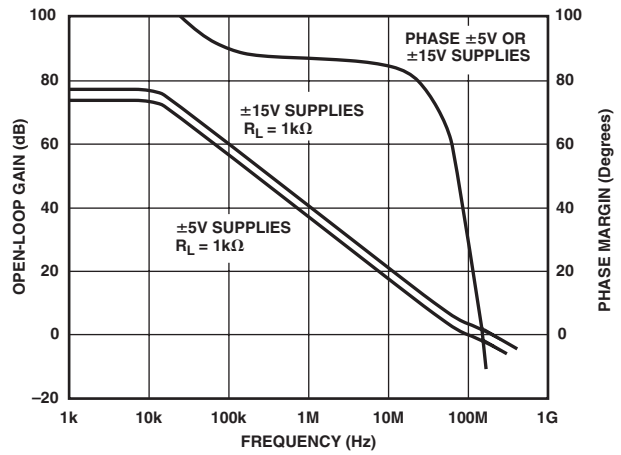

TPC 11. Open-Loop Gain and Phase Margin vs. Frequency

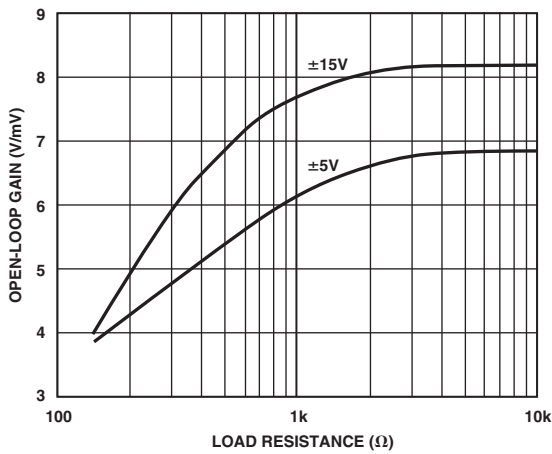

TPC 9. Open-Loop Gain vs. Load Resistance

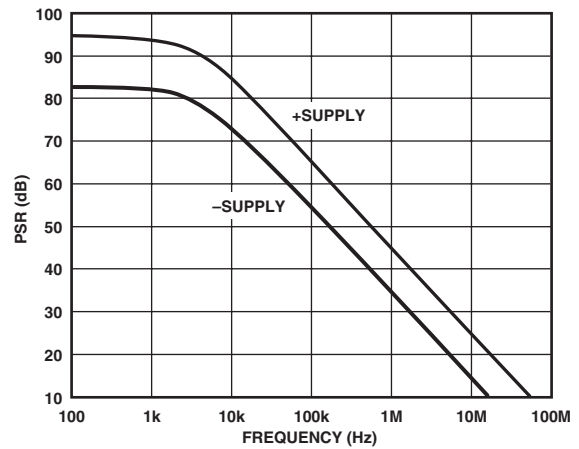

TPC 12. Power Supply Rejection vs. Frequency

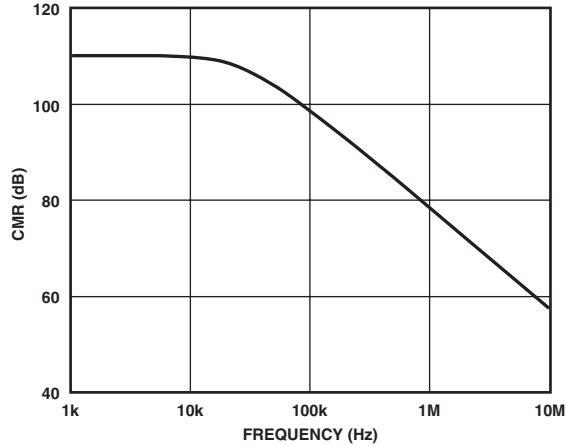

TPC 13. Common-Mode Rejection vs. Frequency

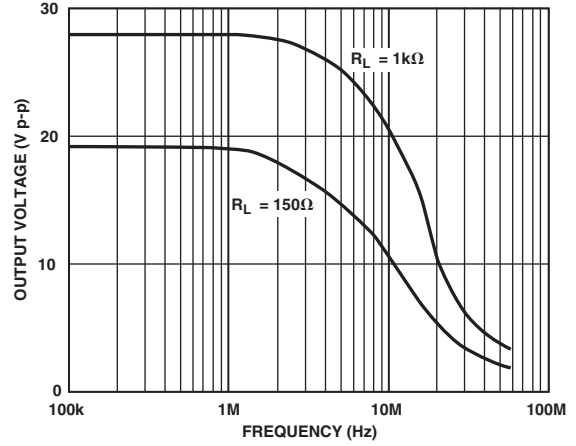

TPC 16. Output Voltage vs. Frequency

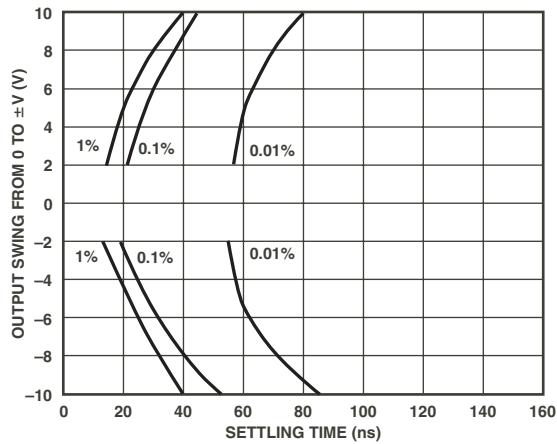

TPC 14. Output Swing and Error vs. Settling Time

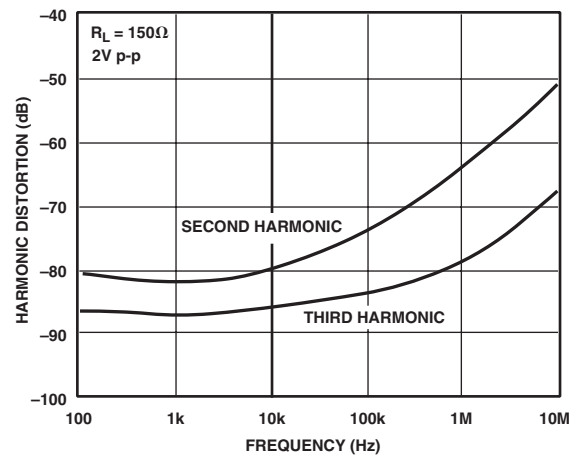

TPC 17. Harmonic Distortion vs. Frequency

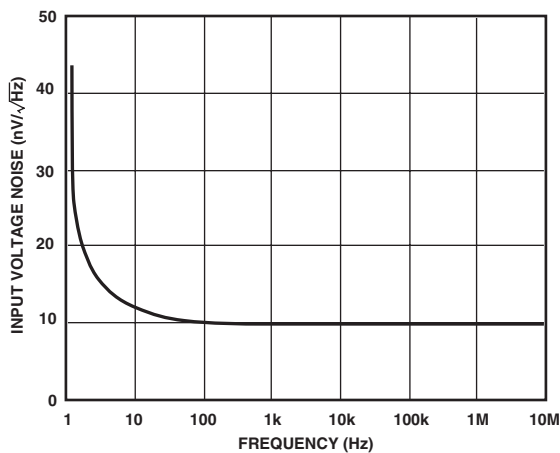

TPC 15. Input Voltage Noise Spectral Density vs. Frequency

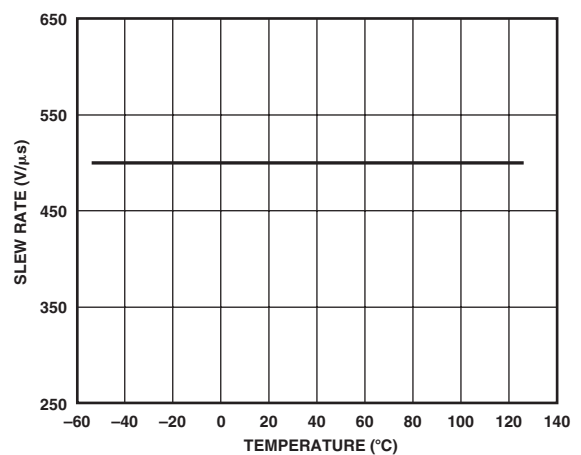

TPC 18. Slew Rate vs. Temperature

# AD818

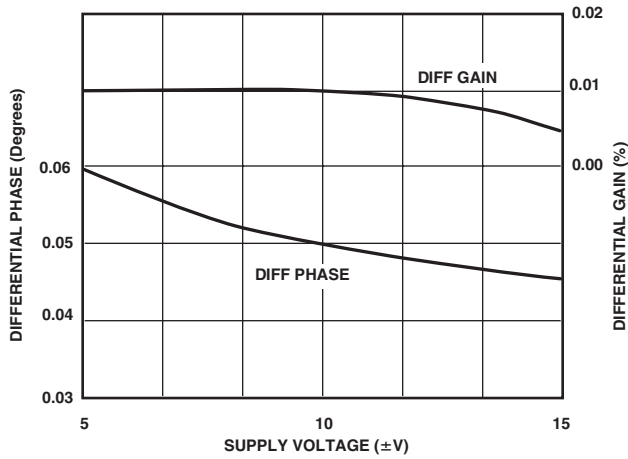

TPC 19. Differential Gain and Phase vs. Supply Voltage

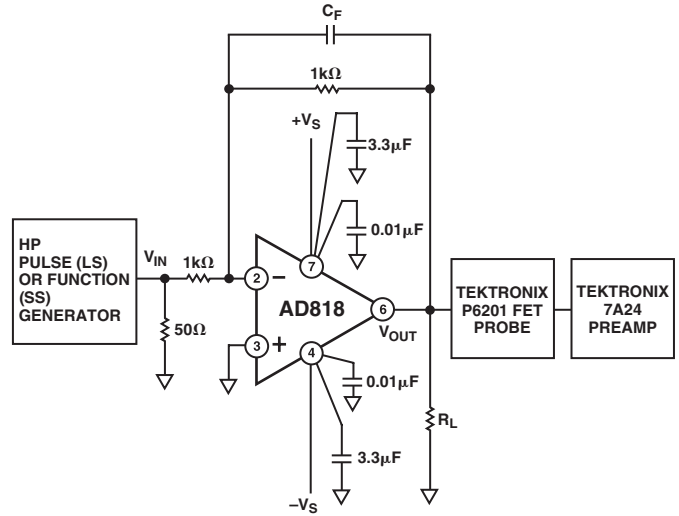

TPC 22. Inverting Amplifier Connection

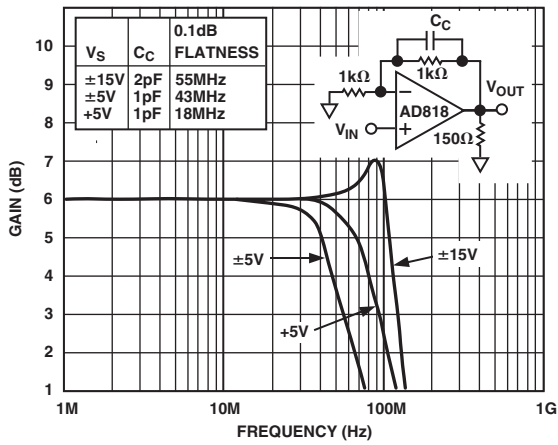

TPC 20. Closed-Loop Gain vs. Frequency ( $G = +2$ )

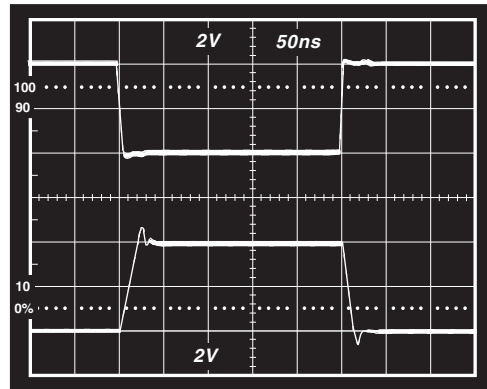

TPC 23. Inverter Large Signal Pulse Response;  $V_S = \pm 5V$ ,  $C_F = 1pF$ ,  $R_L = 1k\Omega$

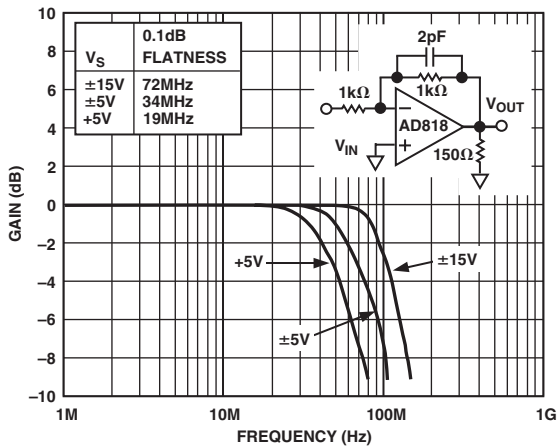

TPC 21. Closed-Loop Gain vs. Frequency ( $G = -1$ )

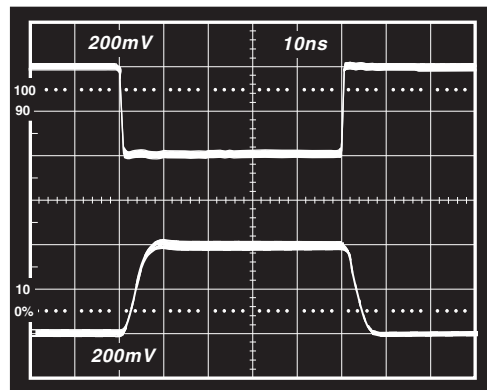

TPC 24. Inverter Small Signal Pulse Response;  $V_S = \pm 5V$ ,  $C_F = 1pF$ ,  $R_L = 150\Omega$



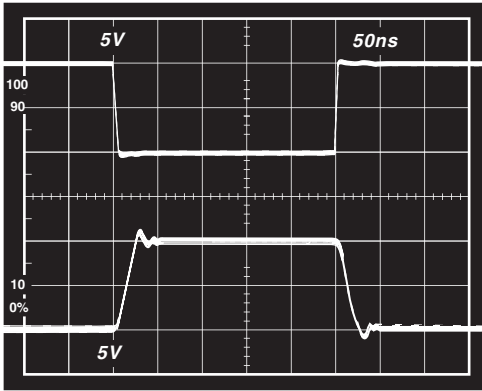

TPC 25. Inverter Large Signal Pulse Response;  $V_S = \pm 15\text{ V}$ ,  $C_F = 1\text{ pF}$ ,  $R_L = 1\text{ k}\Omega$

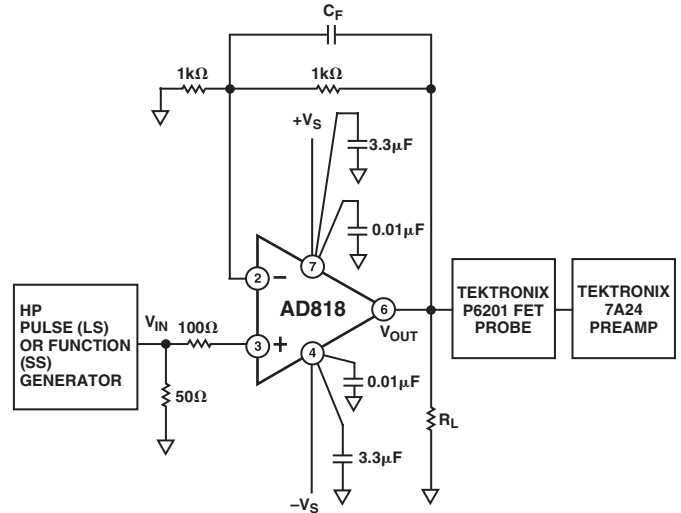

TPC 28. Noninverting Amplifier Connection

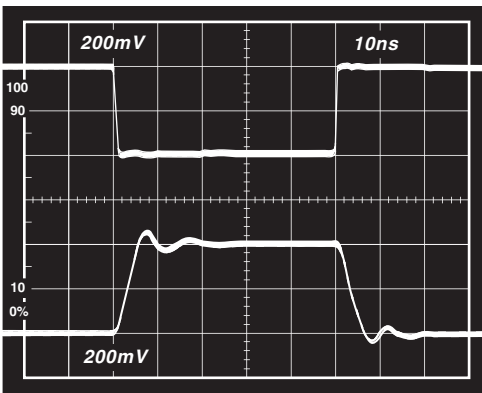

TPC 26. Inverter Small Signal Pulse Response;  $V_S = \pm 15\text{ V}$ ,  $C_F = 1\text{ pF}$ ,  $R_L = 150\ \Omega$

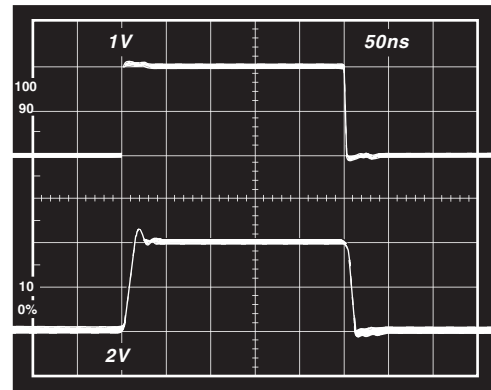

TPC 29. Noninverting Large Signal Pulse Response;  $V_S = \pm 5\text{ V}$ ,  $C_F = 1\text{ pF}$ ,  $R_L = 1\text{ k}\Omega$

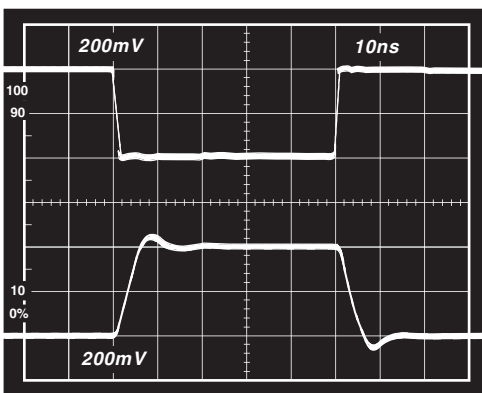

TPC 27. Inverter Small Signal Pulse Response;  $V_S = \pm 5\text{ V}$ ,  $C_F = 0\text{ pF}$ ,  $R_L = 150\ \Omega$

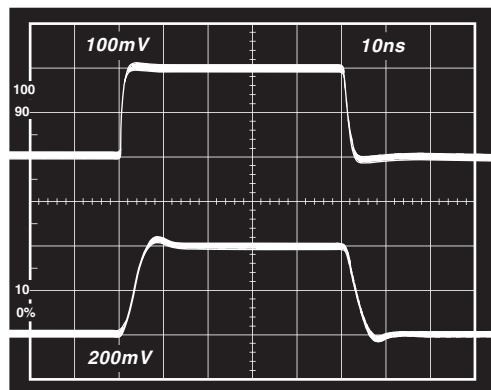

TPC 30. Noninverting Small Signal Pulse Response;  $V_S = \pm 5\text{ V}$ ,  $C_F = 1\text{ pF}$ ,  $R_L = 150\ \Omega$

# AD818

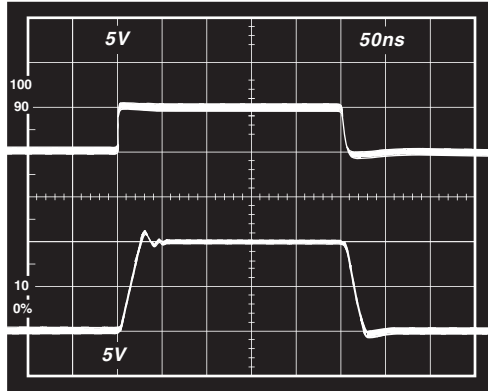

TPC 31. Noninverting Large Signal Pulse Response;  
 $V_S = \pm 15\text{ V}$ ,  $C_F = 1\text{ pF}$ ,  $R_L = 1\text{ k}\Omega$

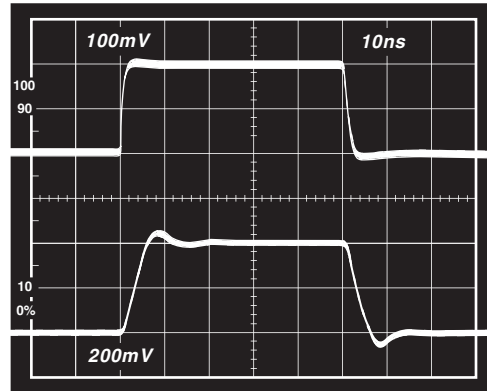

TPC 33. Noninverting Small Signal Pulse Response;  
 $V_S = \pm 5\text{ V}$ ,  $C_F = 0\text{ pF}$ ,  $R_L = 150\text{ }\Omega$

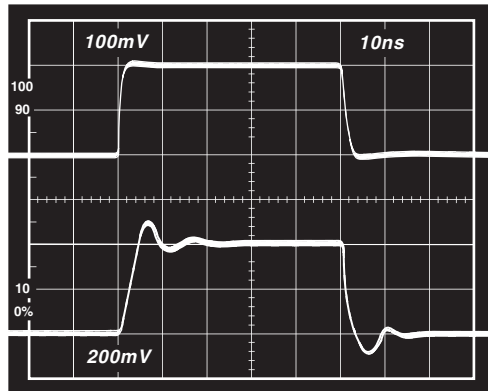

TPC 32. Noninverting Small Signal Pulse Response;  
 $V_S = \pm 15\text{ V}$ ,  $C_F = 1\text{ pF}$ ,  $R_L = 150\text{ }\Omega$

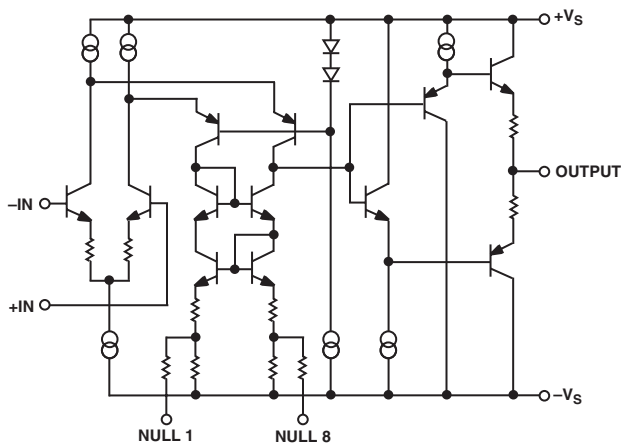

Figure 4. AD818 Simplified Schematic

### THEORY OF OPERATION

The AD818 is a low cost video operational amplifier designed to excel in high performance, high output current video applications.

The AD818 (Figure 4) consists of a degenerated NPN differential pair driving matched PNPs in a folded-cascode gain stage. The output buffer stage employs emitter followers in a class AB amplifier that delivers the necessary current to the load, while maintaining low levels of distortion.

The AD818 will drive terminated cables and capacitive loads of 10 pF or less. As the closed-loop gain is increased, the AD818 will drive heavier capacitive loads without oscillating.

### INPUT CONSIDERATIONS

An input protection resistor ( $R_{IN}$  in TPC 28) is required in circuits where the input to the AD818 will be subjected to transients of continuous overload voltages exceeding the  $\pm 6$  V maximum differential limit. This resistor provides protection for the input transistors by limiting their maximum base current.

For high performance circuits, it is recommended that a “balancing” resistor be used to reduce the offset errors caused by bias current flowing through the input and feedback resistors. The balancing resistor equals the parallel combination of  $R_{IN}$  and  $R_F$  and thus provides a matched impedance at each input terminal. The offset voltage error will then be reduced by more than an order of magnitude.

### GROUNDING AND BYPASSING

When designing high frequency circuits, some special precautions are in order. Circuits must be built with short interconnect leads. When wiring components, care should be taken to provide a low resistance, low inductance path to ground. Sockets should be avoided, since their increased interlead capacitance can degrade circuit bandwidth.

Feedback resistors should be of low enough value ( $\leq 1$  k $\Omega$ ) to ensure that the time constant formed with the inherent stray capacitance at the amplifier’s summing junction will not limit performance. This parasitic capacitance, along with the parallel resistance of  $R_F || R_{IN}$ , forms a pole in the loop transmission, which

may result in peaking. A small capacitance (1 pF–5 pF) may be used in parallel with the feedback resistor to neutralize this effect.

Power supply leads should be bypassed to ground as close as possible to the amplifier pins. Ceramic disc capacitors of 0.1  $\mu$ F are recommended.

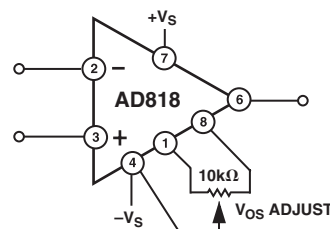

Figure 5. Offset Null Configuration

### OFFSET NULLING

The input offset voltage of the AD818 is inherently very low. However, if additional nulling is required, the circuit shown in Figure 5 can be used. The null range of the AD818 in this configuration is  $\pm 10$  mV.

### SINGLE SUPPLY OPERATION

Another exciting feature of the AD818 is its ability to perform well in a single supply configuration. The AD818 is ideally suited for applications that require low power dissipation and high output current.

Referring to Figure 6, careful consideration should be given to the proper selection of component values. The choices for this particular circuit are:  $R_1 + R_3 || R_2$  combine with  $C_1$  to form a low frequency corner of approximately 10 kHz.  $C_4$  was inserted in series with  $R_4$  to maintain amplifier stability at high frequency.

Combining  $R_3$  with  $C_2$  forms a low-pass filter with a corner frequency of approximately 500 Hz. This is needed to maintain amplifier PSRR, since the supply is connected to  $V_{IN}$  through the input divider. The values for  $R_2$  and  $C_2$  were chosen to demonstrate the AD818’s exceptional output drive capability. In this configuration, the output is centered around 2.5 V. In order to eliminate the static dc current associated with this level,  $C_3$  was inserted in series with  $R_L$ .

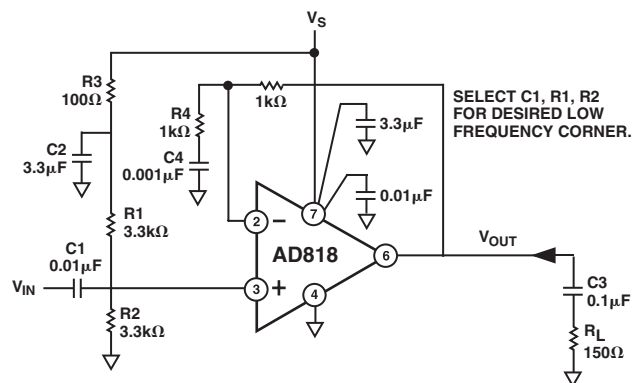

Figure 6. Single-Supply Amplifier Configuration

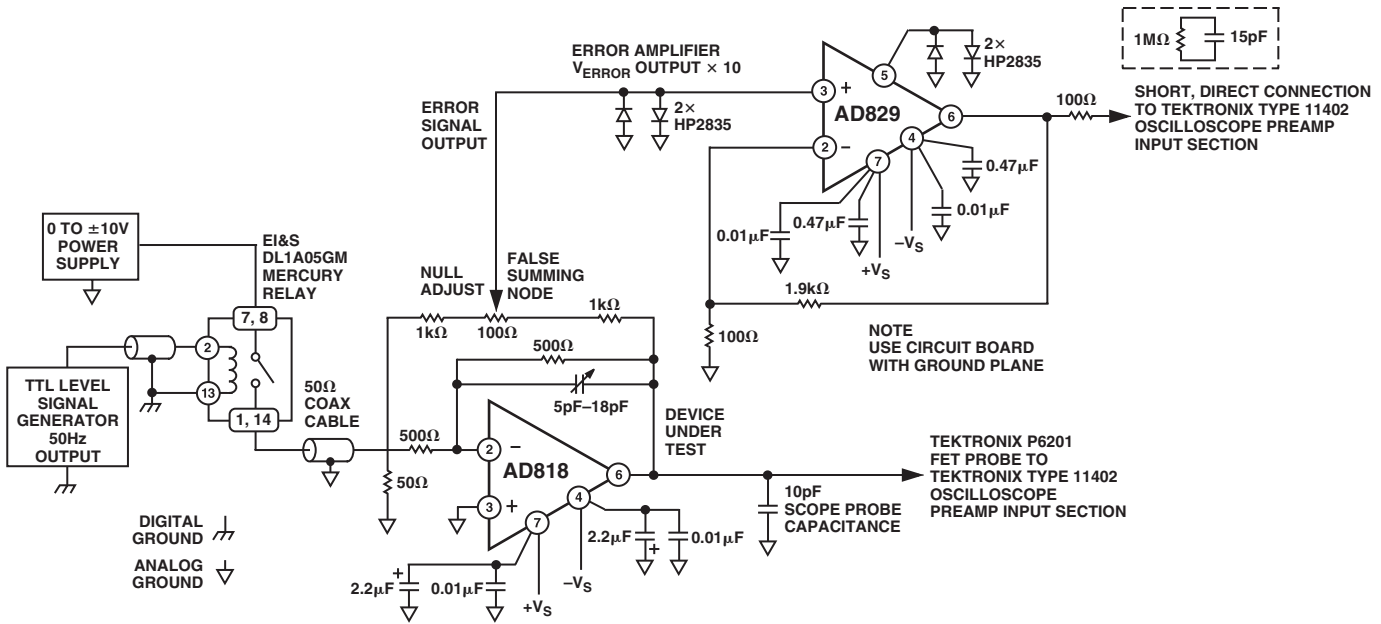

Figure 7. Settling Time Test Circuit

## AD818 SETTLE TIME

Settling time primarily comprises two regions. The first is the slew time in which the amplifier is overdriven, where the output voltage rate of change is at its maximum. The second is the linear time period required for the amplifier to settle to within a specified percentage of the final value.

Measuring the rapid settling time of the AD818 (45 ns to 0.1% and 80 ns to 0.01%—10 V step) requires applying an input pulse with a very fast edge and an extremely flat top. With the AD818 configured in a gain of -1, a clamped false summing junction responds when the output error is within the sum of two diode voltages (approximately 1 V). The signal is then amplified 20 times by a clamped amplifier whose output is connected directly to a sampling oscilloscope.

## A High Performance Video Line Driver

The buffer circuit shown in Figure 8 will drive a back-terminated 75 Ω video line to standard video levels (1 V p-p) with 0.1 dB gain flatness to 55 MHz with only 0.05° and 0.01% differential phase and gain at the 3.58 MHz NTSC subcarrier frequency. This level of performance, which meets the requirements for high definition video displays and test equipment, is achieved using only 7 mA quiescent current.

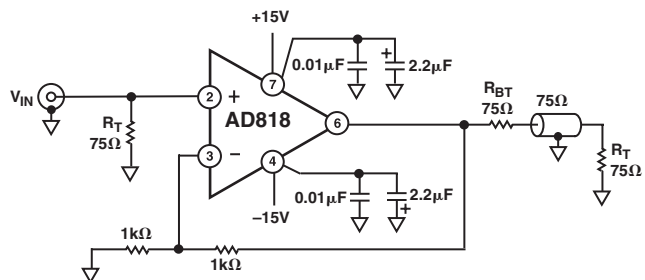

Figure 8. Video Line Driver

## DIFFERENTIAL LINE RECEIVER

The differential receiver circuit of Figure 9 is useful for many applications—from audio to video. It allows extraction of a low level signal in the presence of common-mode noise, as shown in Figure 10.

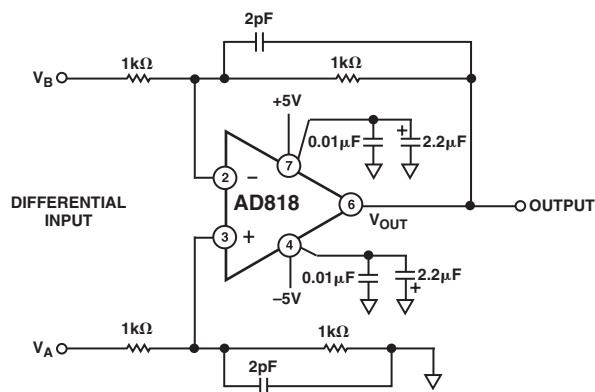

Figure 9. Differential Line Receiver

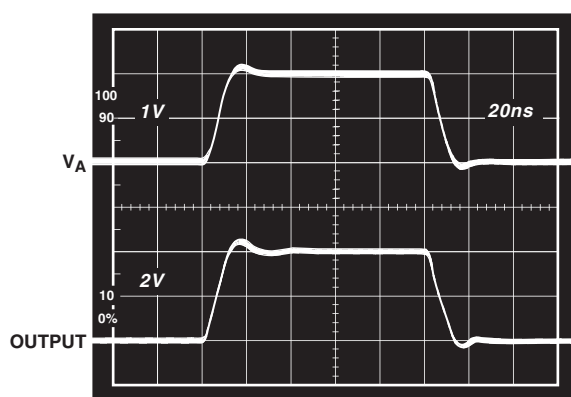
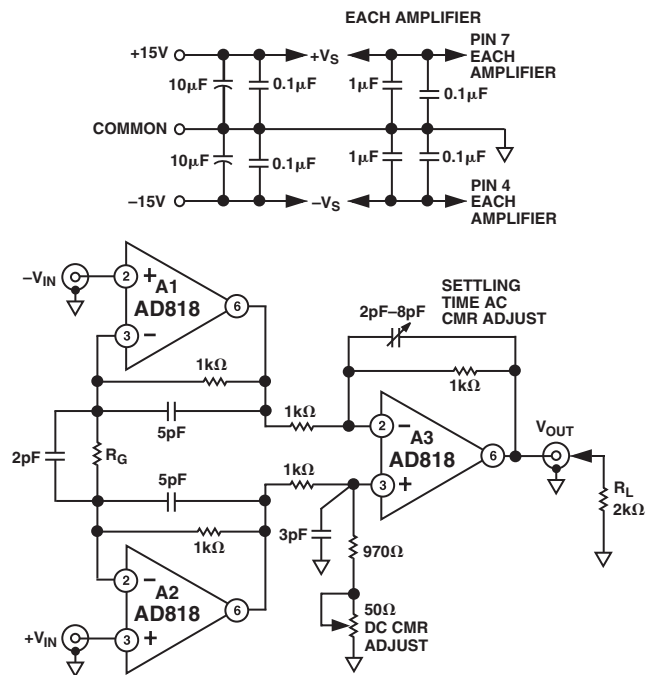

Figure 10. Performance of Line Receiver,  $R_L = 150 \Omega$ ,  $G = +2$

## A HIGH SPEED, 3-OP AMP IN AMP

The circuit of Figure 11 uses three high speed op amps: two AD818s and an AD817. This high speed circuit lends itself well to CCD imaging and other video speed applications. It has the optional flexibility of both dc and ac trims for common-mode rejection, plus the ability to adjust for minimum settling time.



BANDWIDTH, SETTLING TIME, AND TOTAL HARMONIC DISTORTION VS. GAIN

GAIN	$R_G$	CADJ (pF)	SMALL SIGNAL BANDWIDTH	SETTLING TIME TO 0.1%	THD + NOISE BELOW INPUT LEVEL @ 10kHz
3	1kΩ	2-8	14.7MHz	200ns	82dB
10	222Ω	2-8	4.5MHz	370ns	81dB
100	20Ω	2-8	960kHz	2.5μs	71dB

Figure 11. High Speed 3-Op Amp In Amp

OUTLINE DIMENSIONS

8-Lead Plastic Dual In-Line Package [PDIP]  
(N-8)

Dimensions shown in inches and (millimeters)

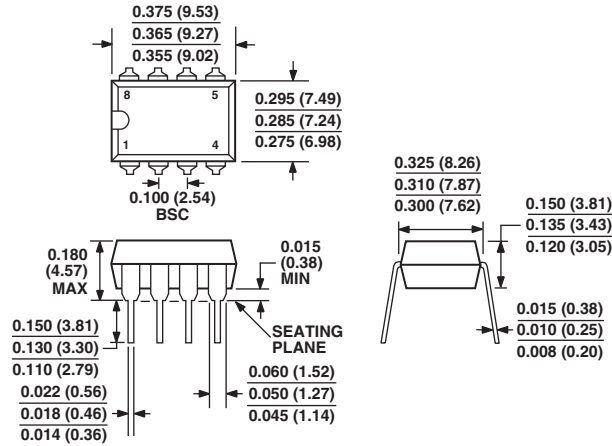

COMPLIANT TO JEDEC STANDARDS MO-095AA  
CONTROLLING DIMENSIONS ARE IN INCHES; MILLIMETER DIMENSIONS (IN PARENTHESES) ARE ROUNDED-OFF INCH EQUIVALENTS FOR REFERENCE ONLY AND ARE NOT APPROPRIATE FOR USE IN DESIGN

8-Lead Standard Small Outline Package [SOIC]  
(R-8)

Dimensions shown in millimeters and (inches)

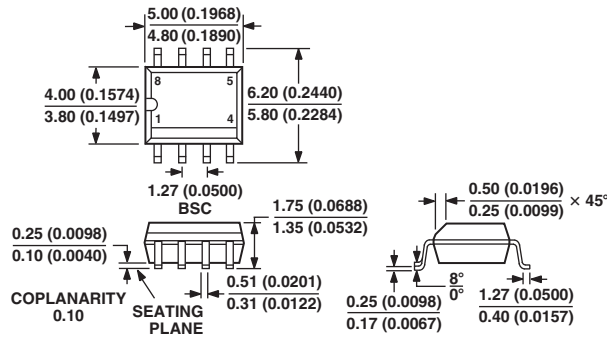

COMPLIANT TO JEDEC STANDARDS MS-012AA  
CONTROLLING DIMENSIONS ARE IN MILLIMETERS; INCH DIMENSIONS (IN PARENTHESES) ARE ROUNDED-OFF MILLIMETER EQUIVALENTS FOR REFERENCE ONLY AND ARE NOT APPROPRIATE FOR USE IN DESIGN

# Revision History

<b>Location</b>	<b>Page</b>
<b>5/03—Data Sheet changed from REV. B to REV. C.</b>	
Renumbered Figures and TPCs .....	Universal
Changes to SPECIFICATIONS .....	2
Changes to ORDERING GUIDE .....	4
Changes to Figures 9 and 10 .....	12
Updated OUTLINE DIMENSIONS .....	14

