

DBL 2056

R.G.B VIDEO PROCESSOR FOR MONITOR

The DBL 2056 is a wideband video amplifier system intended for high resolution RGB color monitor applications. In addition to three matched video amplifiers, the DBL 2056 contains three gated differential input black level clamp comparators for brightness control and three matched attenuator circuits for brightness control and three matched attenuator circuits for contrast control. Each video amplifier contains a gain set or "DRIVE" node for setting maximum system gain ($A_v=4\sim 10$) as well as providing trim capability. The DBL 2056 also contains a voltage reference for the video inputs.

28DIP

Unit : mm

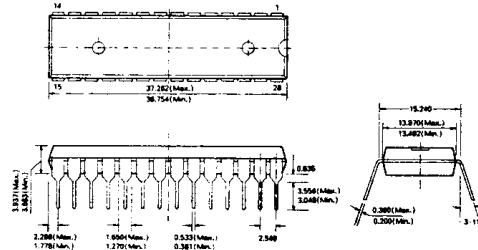

FEATURES

- Three wideband video amplifiers (70MHz, -3dB)
- Inherently matched ($\pm 0.1, 1.2\%$) attenuators for contrast control
- Three externally gated comparators for brightness control
- Provisions for independent gain control (Drive) of each video amplifier
- Video input voltage reference
- Low impedance output driver

USE

- C-TVs, Monitors and Display Applications.

ELECTRICAL CHARACTERISTICS

1. DC Characteristics (Vcc1=Vcc2=12V, Ta=25°C)

Characteristic	Symbol	Test Condition	Min.	Typ.	Max.	Unit
Supply current	I_s	Vcc1 Only	65	73	90	mA
Video Input Reference Voltage	V_{11}		2.2	2.4	2.6	V
Video Input Bias Current	I_b	Any One Amplifier	—	5.0	20	μA
Clamp Gate Low Input Voltage	V_{14L}	Clamp Comparators On	0.8	1.2	—	V
Clamp Gate High Input Voltage	V_{14H}	Clamp Comparators Off	—	1.6	2.0	V
Clamp Gate Low Input Current	I_{14L}	$V_{14}=0V$	—	-0.5	-5.0	μA
Clamp Gate High Input Current	I_{14H}	$V_{14}=12V$	—	0.005	1.0	μA
Clamp Cap Charge Current	I_{clmp+}	$V_{5,8,10}=0V$	650	850	1000	μA
Clamp Cap Discharge Current	I_{clmp-}	$V_{5,8,10}=5V$	-650	-850	-1000	μA
Video Output Low Voltage	V_{OL}	$V_{5,8,10}=0V$	—	0.9	1,25	V
Video Output high Voltage	V_{OH}	$V_{5,8,10}=5V$	8.2	8.9	—	V
Video Output Offset Voltage	$\Delta V_0 (2V)$	Between Any Two Amplifiers $V_{15}=2V$	—	± 0.5	± 50	mV
Video Output Offset Voltage	$\Delta V_0 (4V)$	Between Any Two Amplifiers $V_{15}=4V$	—	± 0.5	± 50	mV

* Unless otherwise specified, S17, 21, 26 Open, V12=6V, V14=0V, V15=2.0V

ELECTRICAL CHARACTERISTICS

2. AC Characteristics (Vcc1 = Vcc2 = 12V, Ta = 25°C)

Characteristic	Symbol	Test Condition	Min.	Typ.	Max.	Unit
Video Amplifier Gain	A_{vmax}	$V_{i2} = 12V$ $V_N = 560mV_{p-p}$	4.5	6.0	6.7	V/V
Attenuation at $V_{i2} = 5V$	ΔA_{v5V}	Ref : A_{vmax} , $V_{i2} = 5V$	—	-1.0	—	dB
Attenuation at $V_{i2} = 2V$	ΔA_{v2V}	Ref : A_{vmax} , $V_{i2} = 2V$	—	-40	—	dB
Absolute Gain Match at A_{vmax}	A_{vmatch}	$V_{i2} = 5V$ (Note 3)	—	± 0.5	—	dB
Gain Change Between Amp.	$\Delta A_{vtrack} 1$	$V_{i2} = 5V$ (Note 3, 6)	—	± 0.1	± 0.5	dB
Gain Change Between Amp.	$\Delta A_{vtrack} 2$	$V_{i2} = 2V$ (Note 3, 6)	—	± 0.3	± 0.7	dB
Video Amplifier Distortion	THD	$V_{i2} = 3V$, $V_o = 1V_{p-p}$	—	0.5	—	%
Video Amplifier Distortion	$f(-3dB)$	$V_{i2} = 12V$, $V_o = 100mV_{rms}$ (Note 2,4)	—	70	—	MHz
Output Rise Time	T_r	$V_o = 4V_{p-p}$ (Note 2)	—	5	—	ns
Output Fall Time	T_f	$V_o = 4V_{p-p}$ (Note 2)	—	7	—	ns
Video Amplifier 10kHz Isolation	V_{sep} (10kHz)	$V_{i2} = 12V$ (Note 5)	—	-65	—	dB
Video Amplifier 10MHz Isolation	V_{sep} (10MHz)	$V_{i2} = 12V$ (Note 2, 5)	—	-45	—	dB

* Unless otherwise specified, S17, 21, 26 Closed, $V_{i4} = 0V$, $V_{i5} = 4V$

Note 1 : Vcc supply pins 1, 13, 23, 28 must be externally wired together to prevent internal damage during Vcc power on/off cycles.

Note 2 : When measuring video amplifier bandwidth or pulse rise and fall times, a double sided full ground plane printed circuit board without socket is recommended.

Note 3 : Measure gain difference between any two amplifiers. $V_{in} = 1V_{p-p}$.

Note 4 : Adjust input frequency from 10KHz(A_{vmax} ref. level) to the -3dB corner frequency($f(-3dB)$).

Note 5 : Measure output levels of the other two undriven amplifiers relative to driven amplifier to determine channel separation. Terminate the undriven Amplifier inputs to simulate generator loading. Repeat test at $f_{in} = 10$ MHz for $V_{sep} = 10MHz$.

Note 6 : ΔA_v track is a measure of the ability of any two amplifiers to track each other and quantifies the matching of the three attenuators. It is the difference in gain change between any two amplifiers with the Contrast Voltage V_{i2} at either 5V or 2V measured relative to an A_{vmax} condition $V_{i2} = 12V$. For example, at A_{vmax} the three amplifiers gains might be 17.4dB, 16.9dB, and 16.4dB and change to 7.3dB, 6.9dB, and 6.5dB respectively for $V_{i2} = 5V$. This Yields the measured typical $\pm 0.1dB$ channel tracking.

DBL 2056

□ TEST CIRCUIT

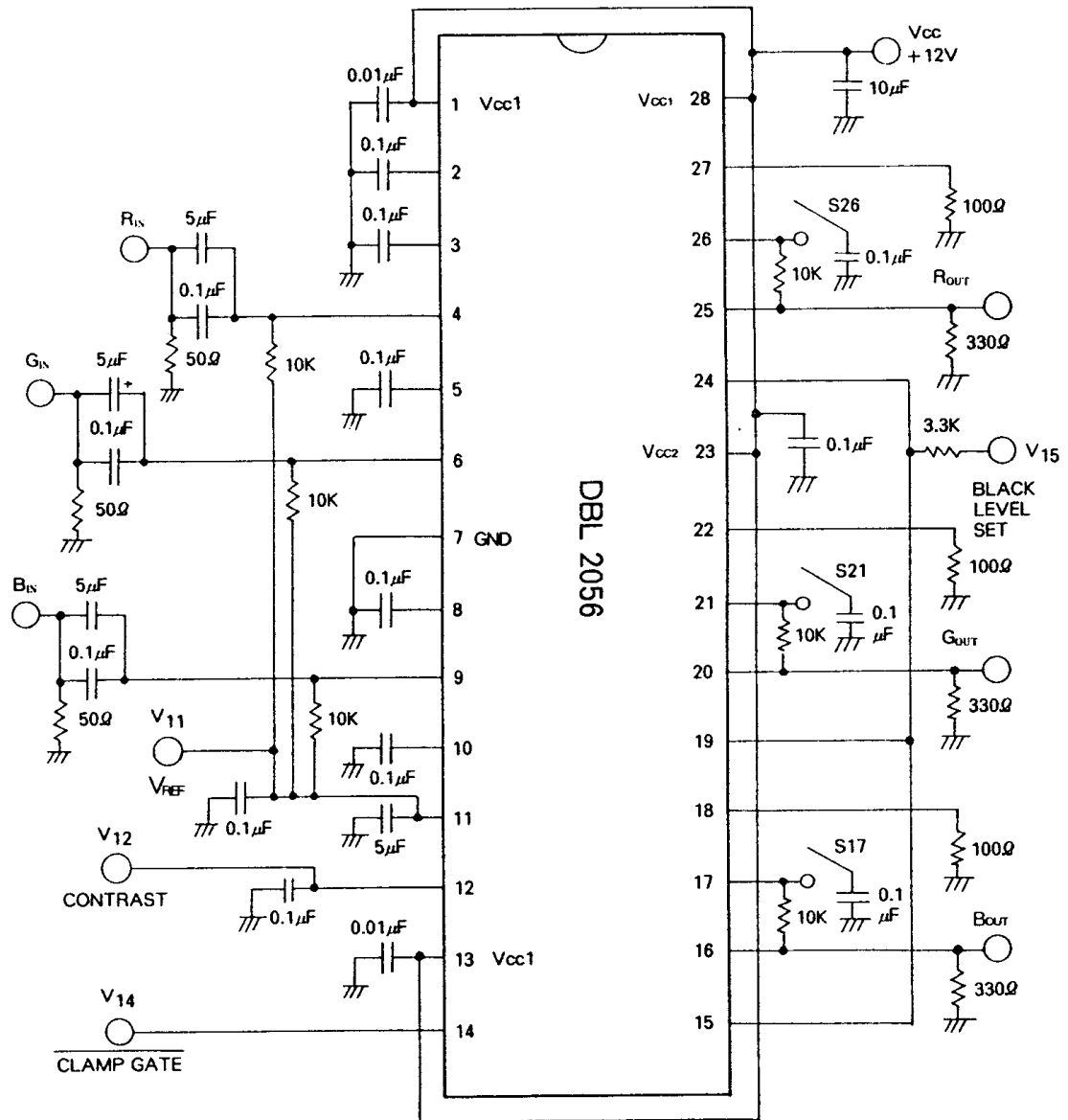

DBL 2056

APPLICATION CIRCUIT

