

16Mb(1M x 16 bit) Low Power SRAM

INFORMATION IN THIS DOCUMENT IS PROVIDED IN RELATION TO SAMSUNG PRODUCTS, AND IS SUBJECT TO CHANGE WITHOUT NOTICE.

NOTHING IN THIS DOCUMENT SHALL BE CONSTRUED AS GRANTING ANY LICENSE, EXPRESS OR IMPLIED, BY ESTOPPEL OR OTHERWISE, TO ANY INTELLECTUAL PROPERTY RIGHTS IN SAMSUNG PRODUCTS OR TECHNOLOGY.

ALL INFORMATION IN THIS DOCUMENT IS PROVIDED ON AS "AS IS" BASIS WITHOUT GUARANTEE OR WARRANTY OF ANY KIND.

1. For updates or additional information about Samsung products, contact your nearest Samsung office.
2. Samsung products are not intended for use in life support, critical care, medical, safety equipment, or similar applications where Product failure could result in loss of life or personal or physical harm, or any military or defense application, or any governmental procurement to which special terms or provisions may apply.

* Samsung Electronics reserves the right to change products or specification without notice.

Document Title**1M x16 bit Super Low Power and Low Voltage Full CMOS Static RAM****Revision History**

<u>Revision No.</u>	<u>History</u>	<u>Draft Date</u>	<u>Remark</u>
0.0	Initial draft	November 14, 2003	Preliminary
1.0	Finalize	March 31, 2005	Final
2.0	Revised - Added Lead Free Products	May 11, 2005	Final

The attached datasheets are provided by SAMSUNG Electronics. SAMSUNG Electronics CO., LTD. reserve the right to change the specifications and products. SAMSUNG Electronics will answer to your questions about device. If you have any questions, please contact the SAMSUNG branch offices.



1M x 16 bit Super Low Power and Low Voltage Full CMOS Static RAM

FEATURES

- Process Technology: Full CMOS
- Organization: 1M x16
- Power Supply Voltage: 2.7~3.3V
- Low Data Retention Voltage: 1.5V(Min)
- Three State Outputs
- Package Type: 48-FBGA - 6.00x7.00

GENERAL DESCRIPTION

The K6F1616U6C families are fabricated by SAMSUNG's advanced full CMOS process technology. The families support industrial operating temperature ranges. The families also support low data retention voltage for battery back-up operation with low data retention current.

PRODUCT FAMILY

Product Family	Operating Temperature	Vcc Range	Speed	Power Dissipation		PKG Type
				Standby (I _{sb1} , Typ.)	Operating (I _{cc1} , Max)	
K6F1616U6C-F	Industrial(-40~85°C)	2.7~3.3V	55 ¹⁾ /70ns	5μA ²⁾	5mA	48-FBGA - 6.00x7.00

1. The parameter is measured with 30pF test load.

2. Typical value is measured at V_{cc}=3.0V, T_A=25°C and not 100% tested.

PIN DESCRIPTION

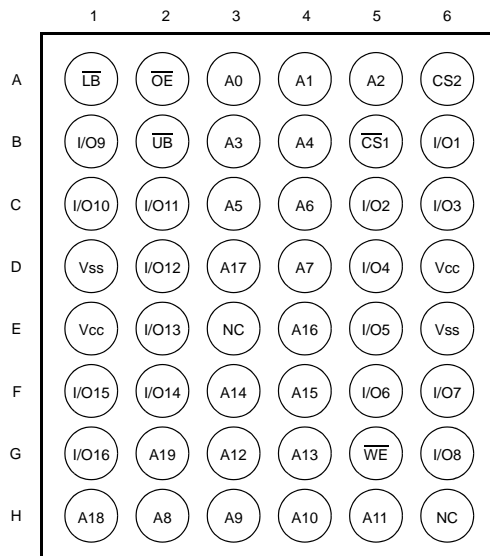

48-FBGA: Top View (Ball Down)

Name	Function	Name	Function
CS1, CS2	Chip Select Inputs	Vcc	Power
OE	Output Enable Input	Vss	Ground
WE	Write Enable Input	UB	Upper Byte(I/O ₉ ~16)
A ₀ ~A ₁₉	Address Inputs	LB	Lower Byte(I/O ₁ ~8)
I/O ₁ ~I/O ₁₆	Data Inputs/Outputs	NC	No Connection

FUNCTIONAL BLOCK DIAGRAM

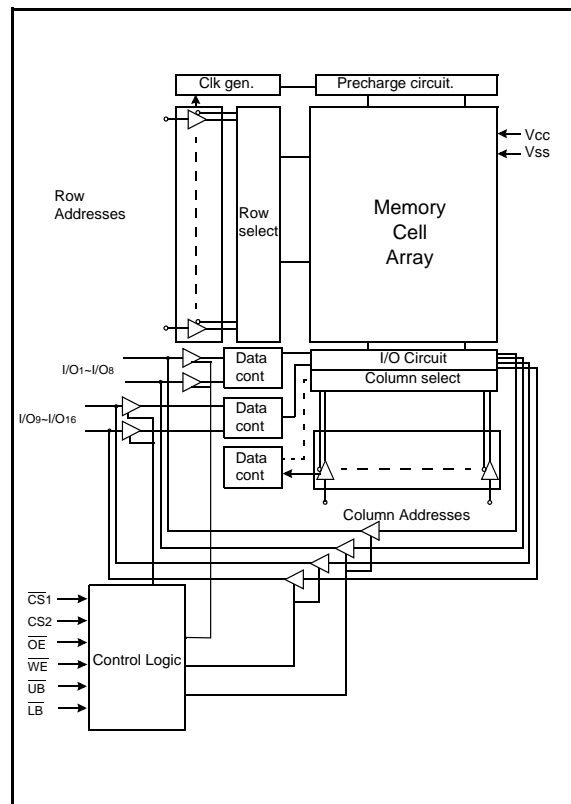

SAMSUNG ELECTRONICS CO., LTD. reserves the right to change products and specifications without notice.

PRODUCT LIST

Industrial Temperature Products(-40~85°C)	
Part Name	Function
K6F1616U6C-FF55	48-FBGA, 55ns, 3.0V
K6F1616U6C-XF55	48-FBGA, 55ns, 3.0V, LF ¹⁾
K6F1616U6C-FF70	48-FBGA, 70ns, 3.0V
K6F1616U6C-XF70	48-FBGA, 70ns, 3.0V, LF ¹⁾

1. LF : Lead Free Product

FUNCTIONAL DESCRIPTION

\overline{CS}_1	CS_2	\overline{OE}	\overline{WE}	\overline{LB}	\overline{UB}	I/O ₁₋₈	I/O ₉₋₁₆	Mode	Power
H	X ¹⁾	X ¹⁾	X ¹⁾	X ¹⁾	X ¹⁾	High-Z	High-Z	Deselected	Standby
X ¹⁾	L	X ¹⁾	X ¹⁾	X ¹⁾	X ¹⁾	High-Z	High-Z	Deselected	Standby
X ¹⁾	X ¹⁾	X ¹⁾	X ¹⁾	H	H	High-Z	High-Z	Deselected	Standby
L	H	H	H	L	X ¹⁾	High-Z	High-Z	Output Disabled	Active
L	H	H	H	X ¹⁾	L	High-Z	High-Z	Output Disabled	Active
L	H	L	H	L	H	Dout	High-Z	Lower Byte Read	Active
L	H	L	H	H	L	High-Z	Dout	Upper Byte Read	Active
L	H	L	H	L	L	Dout	Dout	Word Read	Active
L	H	X ¹⁾	L	L	H	Din	High-Z	Lower Byte Write	Active
L	H	X ¹⁾	L	H	L	High-Z	Din	Upper Byte Write	Active
L	H	X ¹⁾	L	L	L	Din	Din	Word Write	Active

1. X means don't care. (Must be low or high state)

ABSOLUTE MAXIMUM RATINGS¹⁾

Item	Symbol	Ratings	Unit
Voltage on any pin relative to Vss	V _{IN} , V _{OUT}	-0.2 to V _{CC} +0.3V(Max. 3.6V)	V
Voltage on Vcc supply relative to Vss	V _{CC}	-0.2 to 3.6	V
Power Dissipation	P _d	1.0	W
Storage temperature	T _{STG}	-65 to 150	°C
Operating Temperature	T _A	-40 to 85	°C

1. Stresses greater than those listed under "Absolute Maximum Ratings" may cause permanent damage to the device. Functional operation should be restricted to recommended operating condition. Exposure to absolute maximum rating conditions for extended periods may affect reliability.

RECOMMENDED DC OPERATING CONDITIONS¹⁾

Item	Symbol	Min	Typ	Max	Unit
Supply voltage	V _{CC}	2.7	3.0	3.3	V
Ground	V _{SS}	0	0	0	V
Input high voltage	V _{IH}	2.2	-	V _{CC} +0.2 ²⁾	V
Input low voltage	V _{IL}	-0.2 ³⁾	-	0.6	V

Note:

1. T_A=-40 to 85°C, otherwise specified
2. Overshoot: V_{CC}+2.0V in case of pulse width ≤20ns.
3. Undershoot: -2.0V in case of pulse width ≤20ns.
4. Overshoot and Undershoot are sampled, not 100% tested.

CAPACITANCE¹⁾ (f=1MHz, T_A=25°C)

Item	Symbol	Test Condition	Min	Max	Unit
Input capacitance	C _{IN}	V _{IN} =0V	-	8	pF
Input/Output capacitance	C _{IO}	V _{IO} =0V	-	10	pF

1. Capacitance is sampled, not 100% tested

DC AND OPERATING CHARACTERISTICS

Item	Symbol	Test Conditions	Min	Typ ¹⁾	Max	Unit
Input leakage current	I _{LI}	V _{IN} =V _{SS} to V _{CC}	-1	-	1	μA
Output leakage current	I _{LO}	$\overline{CS}_1=V_{IH}$ or $CS_2=V_{IL}$ or $\overline{OE}=V_{IH}$ or $\overline{WE}=V_{IL}$ or $\overline{LB}=\overline{UB}=V_{IH}$, V _{IO} =V _{SS} to V _{CC}	-1	-	1	μA
Average operating current	I _{CC1}	Cycle time=1μs, 100%duty, I _{IO} =0mA, $\overline{CS}_1\leq 0.2V$, $\overline{LB}\leq 0.2V$ or/and $\overline{UB}\leq 0.2V$, $CS_2\geq V_{CC}-0.2V$, V _{IN} ≤0.2V or V _{IN} ≥V _{CC} -0.2V	-	-	5	mA
	I _{CC2}	Cycle time=Min, I _{IO} =0mA, 100% duty, $\overline{CS}_1=V_{IL}$, CS ₂ =V _{IH} , LB=V _{IL} or/and $\overline{UB}=V_{IL}$, V _{IN} =V _{IL} or V _{IH}	70ns 55ns	- -	25 30	
Output low voltage	V _{OL}	I _{OL} = 2.1mA	-	-	0.4	V
Output high voltage	V _{OH}	I _{OH} = -1.0mA	2.4	-	-	V
Standby Current (CMOS)	I _{SB1}	Other input =0-V _{CC} 1) $\overline{CS}_1\geq V_{CC}-0.2V$, $CS_2\geq V_{CC}-0.2V$ (\overline{CS}_1 controlled) or 2) $0V\leq CS_2\leq 0.2V$ (CS ₂ controlled)	-	5.0	25	μA

1. Typical values are measured at V_{CC}=3.0V, T_A=25°C and not 100% tested.

AC OPERATING CONDITIONS

TEST CONDITIONS (Test Load and Input/Output Reference)

Input pulse level: 0.2V to $V_{CC}-0.2V$
 Input rising and falling time: 5ns
 Input and output reference voltage: 1.5V
 Output load (see right): $C_L=100pF+1TTL$
 $C_L=30pF+1TTL$

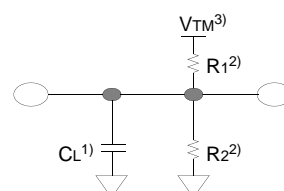

1. Including scope and jig capacitance
2. $R_1=3070\Omega$, $R_2=3150\Omega$
3. $V_{TM}=2.8V$

AC CHARACTERISTICS ($V_{CC}=2.7\sim 3.3V$, $T_A=-40$ to $85^\circ C$)

Parameter List		Symbol	Speed Bins				Units
			55ns		70ns		
			Min	Max	Min	Max	
Read	Read cycle time	t _{RC}	55	-	70	-	ns
	Address access time	t _{AA}	-	55	-	70	ns
	Chip select to output	t _{CO}	-	55	-	70	ns
	Output enable to valid output	t _{OE}	-	25	-	35	ns
	\overline{LB} , \overline{UB} valid to data output	t _{BA}	-	55	-	70	ns
	Chip select to low-Z output	t _{LZ}	10	-	10	-	ns
	Output enable to low-Z output	t _{OLZ}	5	-	5	-	ns
	\overline{LB} , \overline{UB} enable to low-Z output	t _{BLZ}	10	-	10	-	ns
	Output hold from address change	t _{OH}	10	-	10	-	ns
	Chip disable to high-Z output	t _{HZ}	0	20	0	25	ns
	\overline{OE} disable to high-Z output	t _{OHZ}	0	20	0	25	ns
Write	\overline{UB} , \overline{LB} disable to high-Z output	t _{BHZ}	0	20	0	25	ns
	Write cycle time	t _{WC}	55	-	70	-	ns
	Chip select to end of write	t _{CW}	45	-	60	-	ns
	Address set-up time	t _{AS}	0	-	0	-	ns
	Address valid to end of write	t _{AW}	45	-	60	-	ns
	Write pulse width	t _{WP}	40	-	50	-	ns
	Write recovery time	t _{WR}	0	-	0	-	ns
	Write to output high-Z	t _{WHZ}	0	20	0	20	ns
	Data to write time overlap	t _{DW}	25	-	30	-	ns
	Data hold from write time	t _{DH}	0	-	0	-	ns
	End write to output low-Z	t _{OW}	5	-	5	-	ns
\overline{LB} , \overline{UB} valid to end of write	t _{BW}	45	-	60	-	ns	

DATA RETENTION CHARACTERISTICS

Item	Symbol	Test Condition	Min	Typ	Max	Unit
V _{CC} for data retention	VDR	$\overline{CS}_1 \geq V_{CC}-0.2V^{(1)}$, $V_{IN} \geq 0V$	1.5	-	3.3	V
Data retention current	IDR	$V_{CC}=1.5V$, $\overline{CS}_1 \geq V_{CC}-0.2V^{(1)}$, $V_{IN} \geq 0V$	-	1.0 ⁽²⁾	15	μA
Data retention set-up time	t _{SDR}	See data retention waveform	0	-	-	ns
Recovery time	t _{RDR}		t _{RC}	-	-	

1. 1) $\overline{CS}_1 \geq V_{CC}-0.2V$, $CS_2 \geq V_{CC}-0.2V$ (\overline{CS}_1 controlled) or
 2) $0 \leq CS_2 \leq 0.2V$ (CS_2 controlled)
2. Typical value are measured at $T_A=25^\circ C$ and not 100% tested.

TIMING DIAGRAMS

TIMING WAVEFORM OF READ CYCLE(1) (Address Controlled, $\overline{CS1}=\overline{OE}=V_{IL}$, $CS2=\overline{WE}=V_{IH}$, \overline{UB} or/and $\overline{LB}=V_{IL}$)

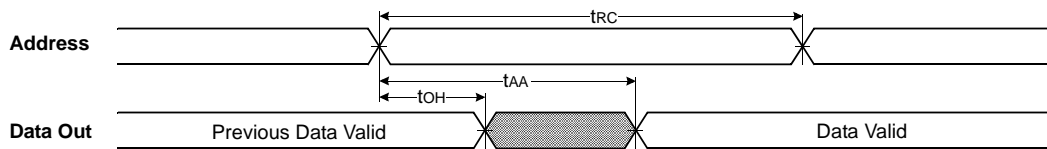

TIMING WAVEFORM OF READ CYCLE(2) ($\overline{WE}=V_{IH}$)

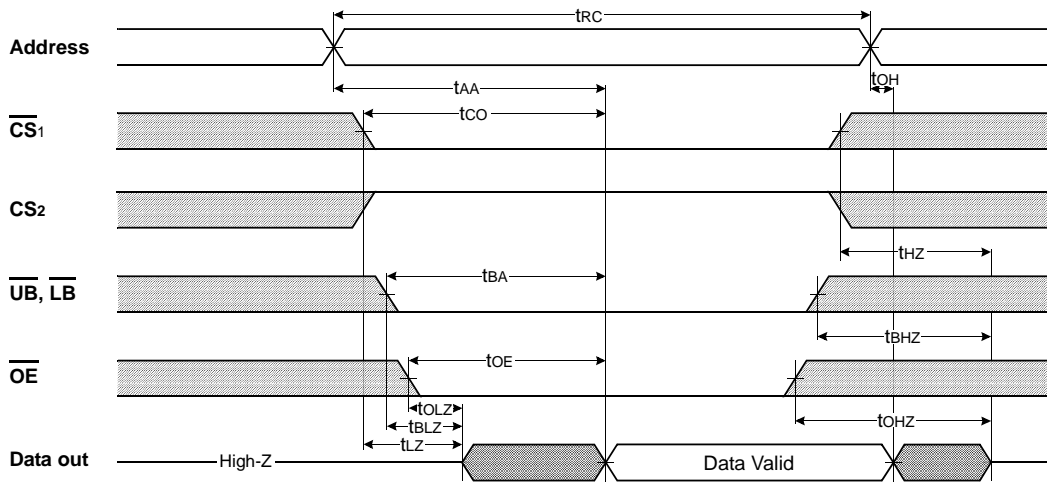

NOTES (READ CYCLE)

1. t_{HZ} and t_{OHZ} are defined as the time at which the outputs achieve the open circuit conditions and are not referenced to output voltage levels.
2. At any given temperature and voltage condition, $t_{HZ}(\text{Max.})$ is less than $t_{LZ}(\text{Min.})$ both for a given device and from device to device interconnection.

TIMING WAVEFORM OF WRITE CYCLE(1) (\overline{WE} Controlled)

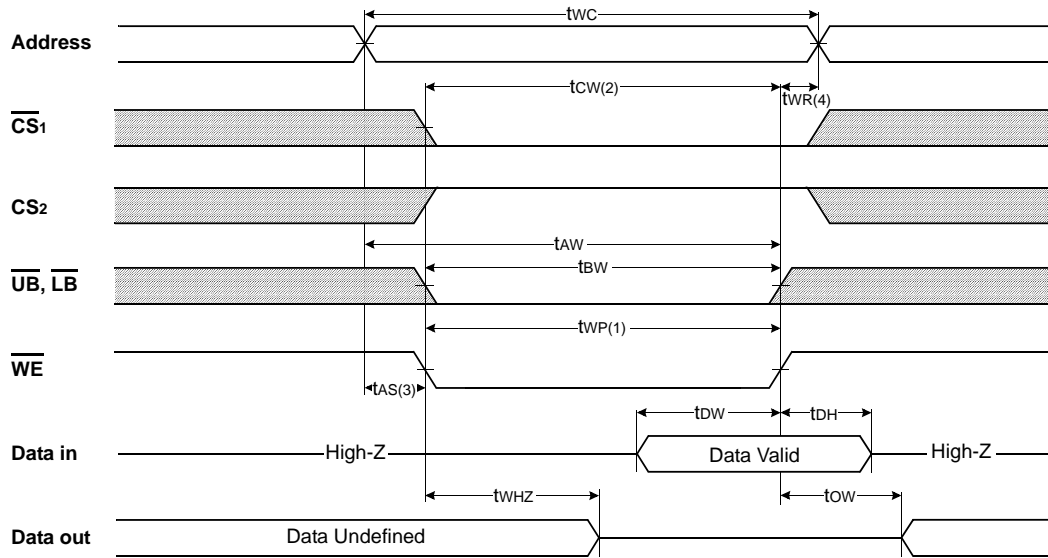

TIMING WAVEFORM OF WRITE CYCLE(2) ($\overline{CS1}$ Controlled)

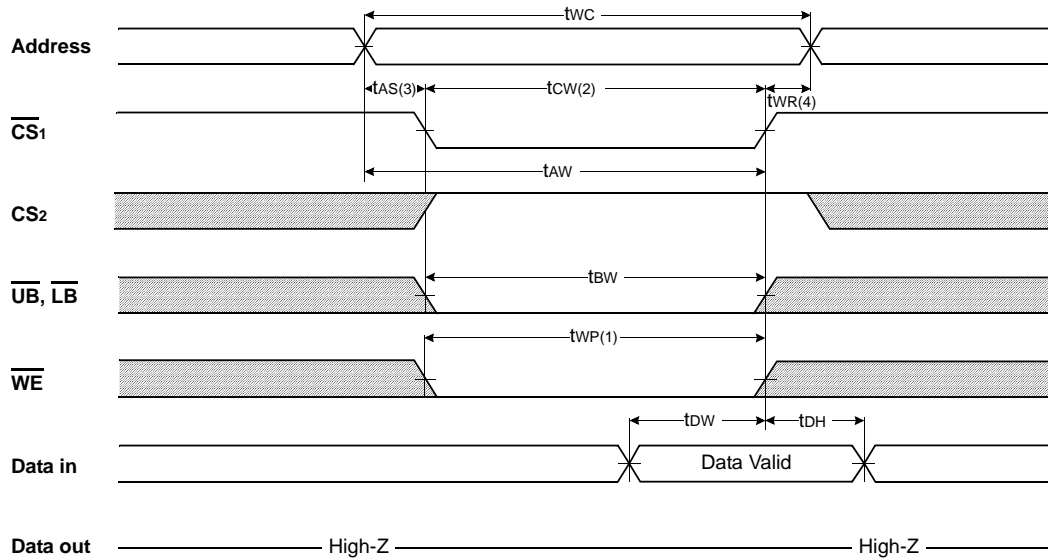

TIMING WAVEFORM OF WRITE CYCLE(3) (\overline{UB} , \overline{LB} Controlled)

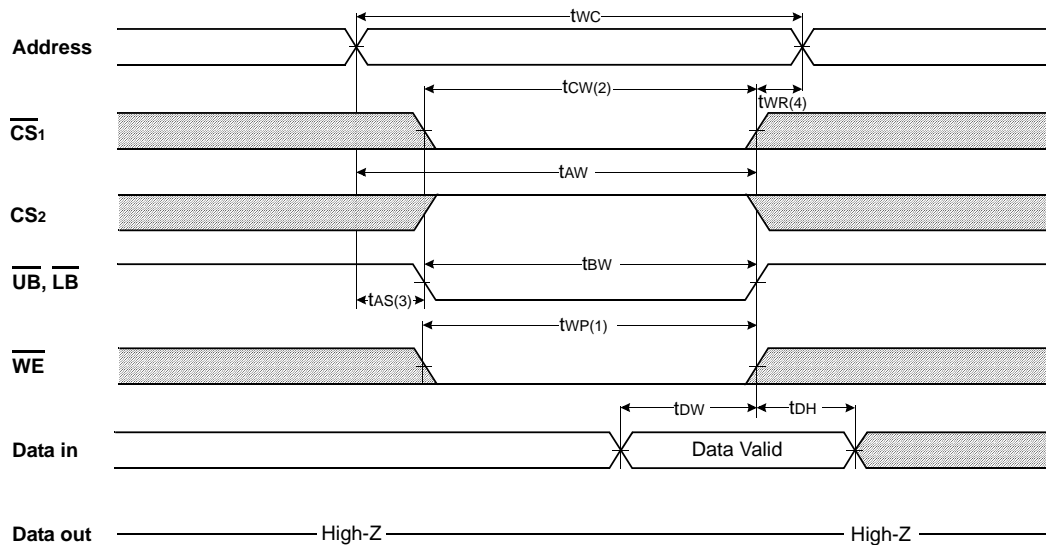

NOTES (WRITE CYCLE)

1. A write occurs during the overlap (t_{WP}) of low $\overline{CS1}$ and low \overline{WE} . A write begins when $\overline{CS1}$ goes low and \overline{WE} goes low with asserting \overline{UB} or \overline{LB} for single byte operation or simultaneously asserting \overline{UB} and \overline{LB} for double byte operation. A write ends at the earliest transition when $\overline{CS1}$ goes high and \overline{WE} goes high. The t_{WP} is measured from the beginning of write to the end of write.
2. t_{CW} is measured from the $\overline{CS1}$ going low to the end of write.
3. t_{AS} is measured from the address valid to the beginning of write.
4. t_{WR} is measured from the end of write to the address change. t_{WR} is applied in case a write ends with $\overline{CS1}$ or \overline{WE} going high.

DATA RETENTION WAVEFORM

$\overline{CS1}$ controlled

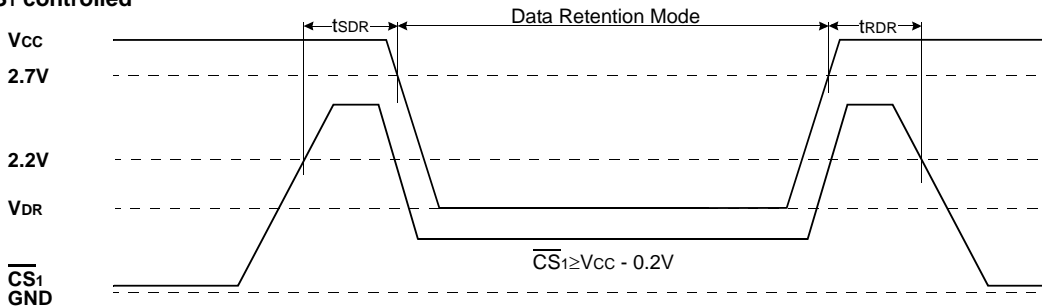

$CS2$ controlled

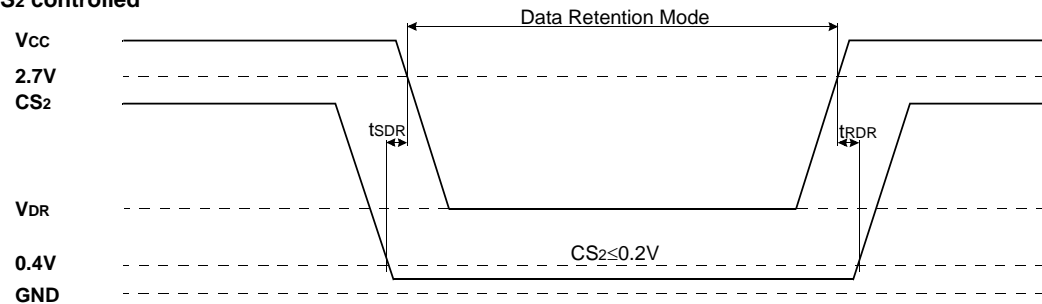

PACKAGE DIMENSION

Unit: millimeters

48 BALL FINE PITCH BGA(0.75mm ball pitch)

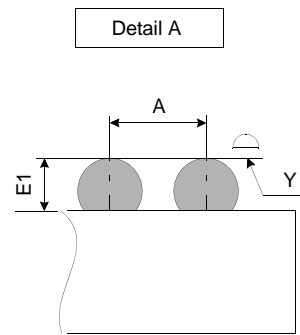
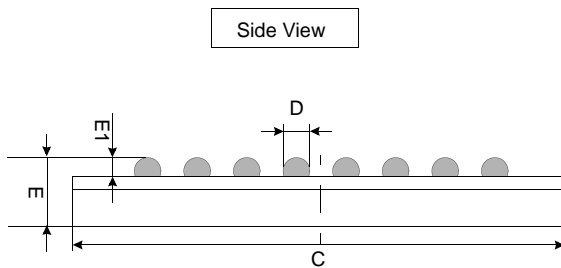
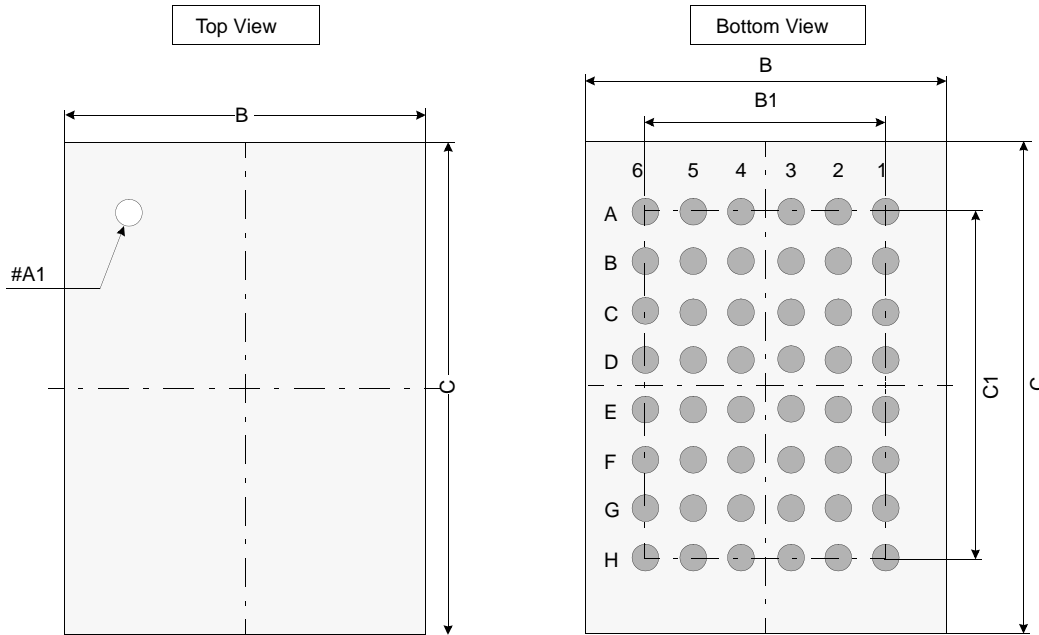

	Min	Typ	Max
A	-	0.75	-
B	5.90	6.00	6.10
B1	-	3.75	-
C	6.90	7.00	7.10
C1	-	5.25	-
D	0.40	0.45	0.50
E	-	-	1.00
E1	0.25	-	-
Y	-	-	0.10

Notes.

1. Bump counts: 48(8 row x 6 column)
2. Bump pitch: (x,y)=(0.75 x 0.75)(typ.)
3. All tolerance are ± 0.050 unless specified beside figure.
4. Typ: Typical
5. Y is coplanarity: 0.10(Max)