

HYB18L256160BF-7.5
HYE18L256160BF-7.5
HYB18L256160BC-7.5
HYE18L256160BC-7.5

DRAMs for Mobile Applications
256-Mbit Mobile-RAM

Memory Products



N e v e r s t o p t h i n k i n g .

Edition 2004-04-30

**Published by Infineon Technologies AG,
St.-Martin-Strasse 53,
81669 München, Germany**

**© Infineon Technologies AG 2004.
All Rights Reserved.**

Attention please!

The information herein is given to describe certain components and shall not be considered as a guarantee of characteristics.

Terms of delivery and rights to technical change reserved.

We hereby disclaim any and all warranties, including but not limited to warranties of non-infringement, regarding circuits, descriptions and charts stated herein.

Information

For further information on technology, delivery terms and conditions and prices please contact your nearest Infineon Technologies Office (www.infineon.com).

Warnings

Due to technical requirements components may contain dangerous substances. For information on the types in question please contact your nearest Infineon Technologies Office.

Infineon Technologies Components may only be used in life-support devices or systems with the express written approval of Infineon Technologies, if a failure of such components can reasonably be expected to cause the failure of that life-support device or system, or to affect the safety or effectiveness of that device or system. Life support devices or systems are intended to be implanted in the human body, or to support and/or maintain and sustain and/or protect human life. If they fail, it is reasonable to assume that the health of the user or other persons may be endangered.

HYB18L256160BF-7.5
HYE18L256160BF-7.5
HYB18L256160BC-7.5
HYE18L256160BC-7.5

DRAMs for Mobile Applications
256-Mbit Mobile-RAM

Memory Products



N e v e r s t o p t h i n k i n g .

HYB18L256160BF-7.5, HYE18L256160BF-7.5, HYB18L256160BC-7.5, HYE18L256160BC-7.5

Revision History:	V1.4	2004-04-30
45	Table 20: t_T removed	
47	Table 23: driver characteristics for half drive and full drive merged	
Previous Version:	V1.3 (Preliminary Datasheet)	2003-03-19
12	power-up sequence: 2 instead of 8 ARF commands required	
47	Table 22: IDD6 specification modified: typ. and max. values given	
Previous Version:	V1.2 (Preliminary Datasheet)	2004-01-28
all	Package option with lead-containing (“black”) balls added	
Previous Version:	V1.1 (Preliminary Datasheet)	2003-12-18
all	-8 speed grade removed	
39	deep power-down exit: clarification added	
45	Table 20: t_{OH} changed	
46	Table 21: IDD parameter values changed	
48	package drawing updated	
Previous Version:	V1.0 (Preliminary Datasheet)	2003-06-23
all	converted to new datasheet template	
all	sales code changed from “AF” to “BF”	
17, 42	Table 6 and Table 16: Deep Power Down mode added	
43	Table 17 (Absolute Maximum Ratings): max. V_{DD} and V_{DDQ} values changed to 2.7V	
46	Table 21: parameters I_{DD2PS} , I_{DD2NS} , I_{DD3PS} and I_{DD3NS} added	
Previous Version:	V0.5 (Target Datasheet)	2003-02
all	sales code changed from “AC” to “AF” (green package)	
7	Table 2 (Memory Addressing Scheme) added	
19	Figure 7 (Mode Register Set Command) corrected	
35	Description of Concurrent Auto Precharge feature modified; Figure 37 to Figure 40 added	
48	Package height reduced to 1.0 mm	
Previous Version:	V0.4 (Target Datasheet)	2002-11
47	Table 23: drive strength values changed	
Previous Version:	V0.3 (Target Datasheet)	2002-11
15	TCSR: temperature sensor activated permanently, making TCSR bits “don’t care”	
46	Table 21: IDD parameter test conditions clarified	
Previous Version:	V0.2 (Target Datasheet)	2002-11
all	complete new test layout, figures and tables	
14	EMRS: bits A5, A6 used for Drive Strength definition	
Previous Version:	V0.1 (Target Datasheet, initial release)	2002-09-06

We Listen to Your Comments

Any information within this document that you feel is wrong, unclear or missing at all?
 Your feedback will help us to continuously improve the quality of this document.
 Please send your proposal (including a reference to this document) to:
techdoc.mp@infineon.com



Table of Contents

1	Overview	7
1.1	Features	7
1.2	Pin Configuration	8
1.3	Description	9
1.4	Pin Definition and Description	10
2	Functional Description	11
2.1	Power On and Initialization	11
2.2	Register Definition	12
2.2.1	Mode Register	12
2.2.1.1	Burst Length	13
2.2.1.2	Burst Type	13
2.2.1.3	Read Latency	14
2.2.1.4	Write Burst Mode	14
2.2.1.5	Extended Mode Register	14
2.2.1.6	Partial Array Self Refresh (PASR)	14
2.2.1.7	Temperature Compensated Self Refresh (TCSR) with On-Chip Temperature Sensor	15
2.2.1.8	Selectable Drive Strength	15
2.3	State Diagram	16
2.4	Commands	17
2.4.1	NO OPERATION (NOP)	18
2.4.2	DESELECT	18
2.4.3	MODE REGISTER SET	19
2.4.4	ACTIVE	20
2.4.5	READ	21
2.4.5.1	READ Burst Termination	25
2.4.5.2	Clock Suspend Mode for READ Cycles	25
2.4.5.3	READ - DQM Operation	26
2.4.5.4	READ to WRITE	26
2.4.5.5	READ to PRECHARGE	27
2.4.6	WRITE	28
2.4.6.1	WRITE Burst Termination	31
2.4.6.2	Clock Suspend Mode for WRITE Cycles	31
2.4.6.3	WRITE - DQM Operation	32
2.4.6.4	WRITE to READ	32
2.4.6.5	WRITE to PRECHARGE	33
2.4.7	BURST TERMINATE	33
2.4.8	PRECHARGE	34
2.4.8.1	AUTO PRECHARGE	34
2.4.8.2	CONCURRENT AUTO PRECHARGE	35
2.4.9	AUTO REFRESH and SELF REFRESH	37
2.4.9.1	AUTO REFRESH	37
2.4.9.2	SELF REFRESH	38
2.4.10	POWER DOWN	39
2.4.10.1	DEEP POWER DOWN	39
2.5	Function Truth Tables	40
3	Electrical Characteristics	43
3.1	Operating Conditions	43
3.2	AC Characteristics	45
3.3	Operating Currents	46
3.4	Pullup and Pulldown Characteristics	47
4	Package Outlines	48

List of Figures

Figure 1	Standard Ballout 256-Mbit Mobile-RAM	8
Figure 2	Functional Block Diagram	9
Figure 3	Power-Up Sequence and Mode Register Sets	11
Figure 4	State Diagram	16
Figure 5	Address / Command Inputs Timing Parameters	17
Figure 6	No Operation Command	18
Figure 7	Mode Register Set Command	19
Figure 8	Mode Register Definition	19
Figure 9	ACTIVE Command	20
Figure 10	Bank Activate Timings	20
Figure 11	READ Command	21
Figure 12	Basic READ Timing Parameters for DQs	21
Figure 13	Single READ Burst (CAS Latency = 2)	22
Figure 14	Single READ Burst (CAS Latency = 3)	23
Figure 15	Consecutive READ Bursts	23
Figure 16	Random READ Bursts	24
Figure 17	Non-Consecutive READ Bursts	24
Figure 18	Terminating a READ Burst	25
Figure 19	Clock Suspend Mode for READ Bursts	25
Figure 20	READ Burst - DQM Operation	26
Figure 21	READ to WRITE Timing	26
Figure 22	READ to PRECHARGE Timing	27
Figure 23	WRITE Command	28
Figure 24	Basic WRITE Timing Parameters for DQs	28
Figure 25	WRITE Burst (CAS Latency = 2)	29
Figure 26	WRITE Burst (CAS Latency = 3)	29
Figure 27	Consecutive WRITE Bursts	30
Figure 28	Random WRITE Bursts	30
Figure 29	Non-Consecutive WRITE Bursts	30
Figure 30	Terminating a WRITE Burst	31
Figure 31	Clock Suspend Mode for WRITE Bursts	31
Figure 32	WRITE Burst - DQM Operation	32
Figure 33	WRITE to READ Timing	32
Figure 34	WRITE to PRECHARGE Timing	33
Figure 35	BURST TERMINATE Command	33
Figure 36	PRECHARGE Command	34
Figure 37	READ with Auto Precharge Interrupted by READ	35
Figure 38	READ with Auto Precharge Interrupted by WRITE	35
Figure 39	WRITE with Auto Precharge Interrupted by READ	36
Figure 40	WRITE with Auto Precharge Interrupted by WRITE	36
Figure 41	AUTO REFRESH Command	37
Figure 42	Auto Refresh	37
Figure 43	SELF REFRESH Entry Command	38
Figure 44	Self Refresh Entry and Exit	38
Figure 45	Power Down Entry Command	39
Figure 46	Power Down Entry and Exit	39
Figure 47	P-VFBGA-54-2 (Plastic Very Thin Fine Ball Grid Array Package)	48

1 Overview

1.1 Features

- 4 banks × 4 Mbit × 16 organization
- Fully synchronous to positive clock edge
- Four internal banks for concurrent operation
- Programmable CAS latency: 2, 3
- Programmable burst length: 1, 2, 4, 8 or full page
- Programmable wrap sequence: sequential or interleaved
- Programmable drive strength
- Auto refresh and self refresh modes
- 8192 refresh cycles / 64 ms
- Auto precharge
- Commercial (0°C to +70°C) and Extended (-25°C to +85°C) operating temperature range
- 54-ball P-VFBGA package (12.0 × 8.0 × 1.0 mm)

Power Saving Features

- Low supply voltages: $V_{DD} = 1.8 \text{ V} \pm 0.15 \text{ V}$, $V_{DDQ} = 1.8 \text{ V} \pm 0.15 \text{ V}$
- Optimized self refresh (I_{DD6}) and standby currents (I_{DD2}/I_{DD3})
- Programmable Partial Array Self Refresh (PASR)
- Temperature Compensated Self-Refresh (TCSR), controlled by on-chip temperature sensor
- Power-Down and Deep Power Down modes

Table 1 Performance

Part Number Speed Code		- 7.5	Unit
Speed Grade		133	MHz
Access Time (t_{ACmax})	CL = 3	5.4	ns
	CL = 2	6.0	ns
Clock Cycle Time (t_{CKmin})	CL = 3	7.5	ns
	CL = 2	9.5	ns

Table 2 Memory Addressing Scheme

Item	Addresses
Banks	BA0, BA1
Rows	A0 - A12
Columns	A0 - A8

Table 3 Ordering Information

Type ¹⁾	Package	Description
Commercial Temperature Range		
HYB18L256160BC-7.5	P-VFBGA-54-2	133 MHz 4 Banks × 4 Mbit × 16 LP-SDRAM
HYB18L256160BF-7.5	P-VFBGA-54-2	133 MHz 4 Banks × 4 Mbit × 16 LP-SDRAM 

Extended Temperature Range

HYE18L256160BC-7.5	P-VFBGA-54-2	133 MHz 4 Banks × 4 Mbit × 16 LP-SDRAM
HYE18L256160BF-7.5	P-VFBGA-54-2	133 MHz 4 Banks × 4 Mbit × 16 LP-SDRAM 

- 1) HYB / HYE: Designator for memory products (HYB: standard temp. range; HYE: extended temp. range)
 18L: 1.8V Mobile-RAM
 256: 256 MBit density
 160: 16 bit interface width
 B: die revision
 C / F: lead-containing product (C) / green product (F)
 -7.5: speed grade(s): min. clock cycle time

1.2 Pin Configuration

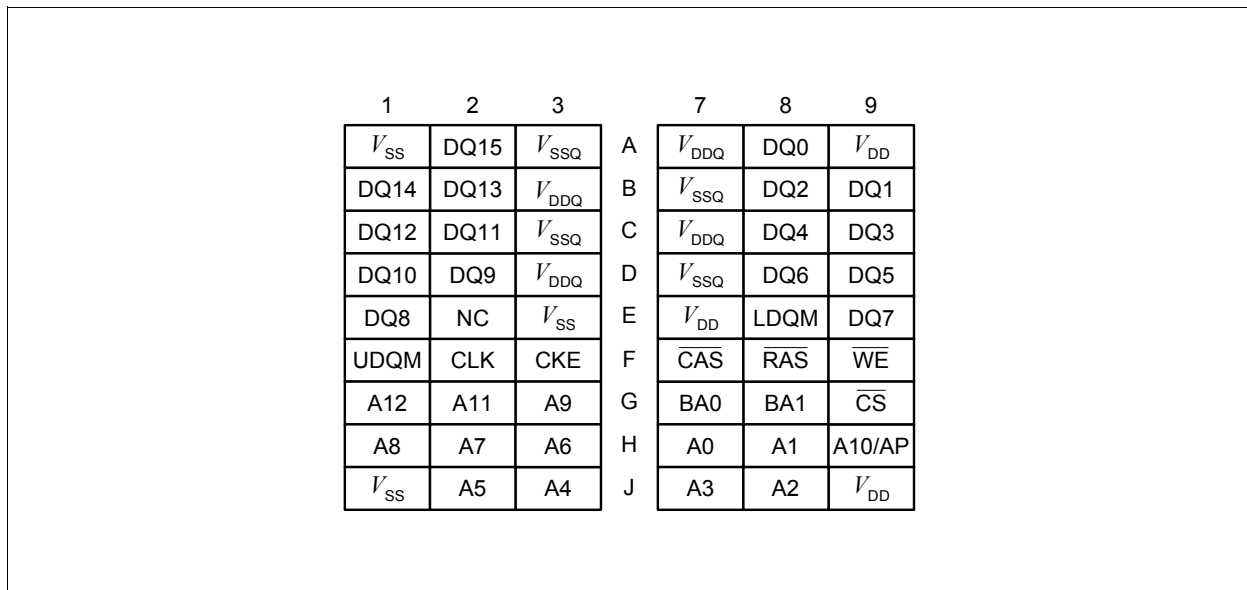

Figure 1 Standard Ballout 256-Mbit Mobile-RAM

1.3 Description

The HY[B/E]18L256160B[C/F] is a high-speed CMOS, dynamic random-access memory containing 268,435,456 bits. It is internally configured as a quad-bank DRAM.

The HY[B/E]18L256160B[C/F] achieves high speed data transfer rates by employing a chip architecture that prefetches multiple bits and then synchronizes the output data to the system clock. Read and write accesses are burst-oriented; accesses start at a selected location and continue for a programmed number of locations (1, 2, 4, 8 or full page) in a programmed sequence.

The device operation is fully synchronous: all inputs are registered at the positive edge of CLK.

The HY[B/E]18L256160B[C/F] is especially designed for mobile applications. It operates from a 1.8V power supply. Power consumption in self refresh mode is drastically reduced by an On-Chip Temperature Sensor (OCTS); it can further be reduced by using the programmable Partial Array Self Refresh (PASR).

A conventional data-retaining Power-Down (PD) mode is available as well as a non-data-retaining Deep Power-Down (DPD) mode.

The HY[B/E]18L256160B[C/F] is housed in a 54-ball P-VFPGA package. It is available in Commercial (0 °C to 70 °C) and Extended (-25 °C to +85 °C) temperature range.

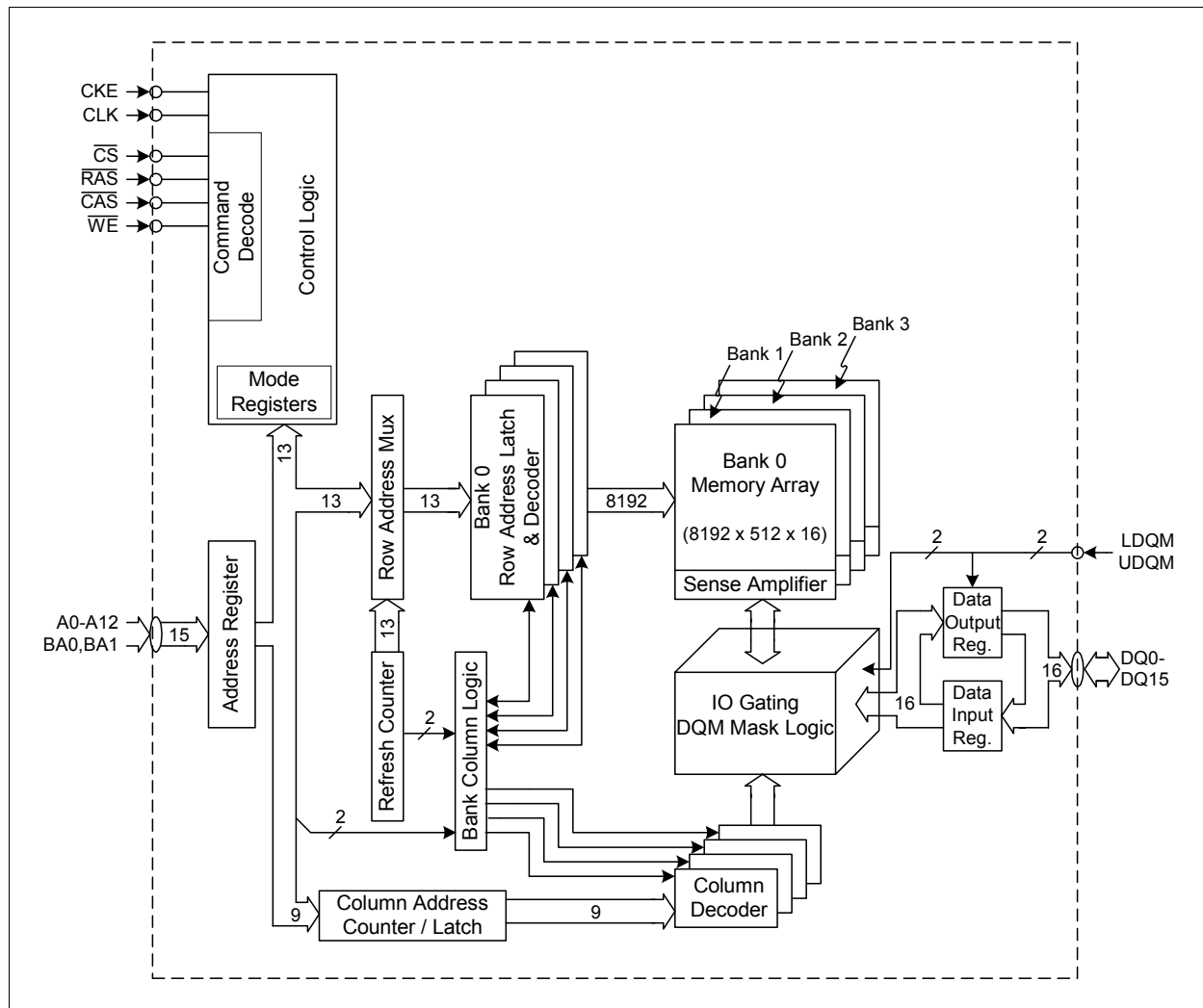

Figure 2 Functional Block Diagram

1.4 Pin Definition and Description

Table 4 Pin Description

Ball	Type	Detailed Function
CLK	Input	Clock: all inputs are sampled on the positive edge of CLK.
CKE	Input	Clock Enable: CKE HIGH activates and CKE LOW deactivates internal clock signals, device input buffers and output drivers. Taking CKE LOW provides PRECHARGE POWER-DOWN and SELF REFRESH operation (all banks idle), ACTIVE POWER-DOWN (row active in any bank) or SUSPEND (access in progress). Input buffers, excluding CLK and CKE are disabled during power-down. Input buffers, excluding CKE are disabled during SELF REFRESH.
\overline{CS}	Input	Chip Select: All commands are masked when \overline{CS} is registered HIGH. \overline{CS} provides for external bank selection on systems with multiple memory banks. \overline{CS} is considered part of the command code.
\overline{RAS} , \overline{CAS} , \overline{WE}	Input	Command Inputs: RAS, \overline{CAS} and \overline{WE} (along with \overline{CS}) define the command being entered.
DQ0 - DQ15	I/O	Data Inputs/Output: Bi-directional data bus (16 bit)
LDQM, UDQM	Input	Input/Output Mask: input mask signal for WRITE cycles and output enable for READ cycles. For WRITES, DQM acts as a data mask when HIGH. For READS, DQM acts as an output enable and places the output buffers in High-Z state when HIGH (two clocks latency). LDQM corresponds to the data on DQ0 - DQ7; UDQM to the data on DQ8 - DQ15.
BA0, BA1	Input	Bank Address Inputs: BA0 and BA1 define to which bank an ACTIVATE, READ, WRITE or PRECHARGE command is being applied. BA0, BA1 also determine which mode register is to be loaded during a MODE REGISTER SET command (MRS or EMRS).
A0 - A12	Input	Address Inputs: A0 - A12 define the row address during an ACTIVE command cycle. A0 - A8 define the column address during a READ or WRITE command cycle. In addition, A10 (= AP) controls Auto Precharge operation at the end of the burst read or write cycle. During a PRECHARGE command, A10 (= AP) in conjunction with BA0, BA1 controls which bank(s) are to be precharged: if A10 is HIGH, all four banks will be precharged regardless of the state of BA0 and BA1; if A10 is LOW, BA0, BA1 define the bank to be precharged. During MODE REGISTER SET commands, the address inputs hold the op-code to be loaded.
V_{DDQ}	Supply	I/O Power Supply: Isolated power for DQ output buffers for improved noise immunity: $V_{DDQ} = 1.8\text{ V} \pm 0.15\text{ V}$
V_{SSQ}	Supply	I/O Ground
V_{DD}	Supply	Power Supply: Power for the core logic and input buffers, $V_{DD} = 1.8\text{ V} \pm 0.15\text{ V}$
V_{SS}	Supply	Ground
N.C.	–	No Connect

2 Functional Description

The 256-Mbit Mobile-RAM is a high-speed CMOS, dynamic random-access memory containing 268,435,456 bits. It is internally configured as a quad-bank DRAM.

READ and WRITE accesses to the Mobile-RAM are burst oriented; accesses start at a selected location and continue for a programmed number of locations in a programmed sequence. Accesses begin with the registration of an ACTIVE command, followed by a READ or WRITE command. The address bits registered coincident with the ACTIVE command are used to select the bank and row to be accessed (BA0, BA1 select the banks, A0 - A12 select the row). The address bits registered coincident with the READ or WRITE command are used to select the starting column location for the burst access.

Prior to normal operation, the Mobile-RAM must be initialized. The following sections provide detailed information covering device initialization, register definition, command description and device operation.

2.1 Power On and Initialization

The Mobile-RAM must be powered up and initialized in a predefined manner (see [Figure 3](#)). Operational procedures other than those specified may result in undefined operation.

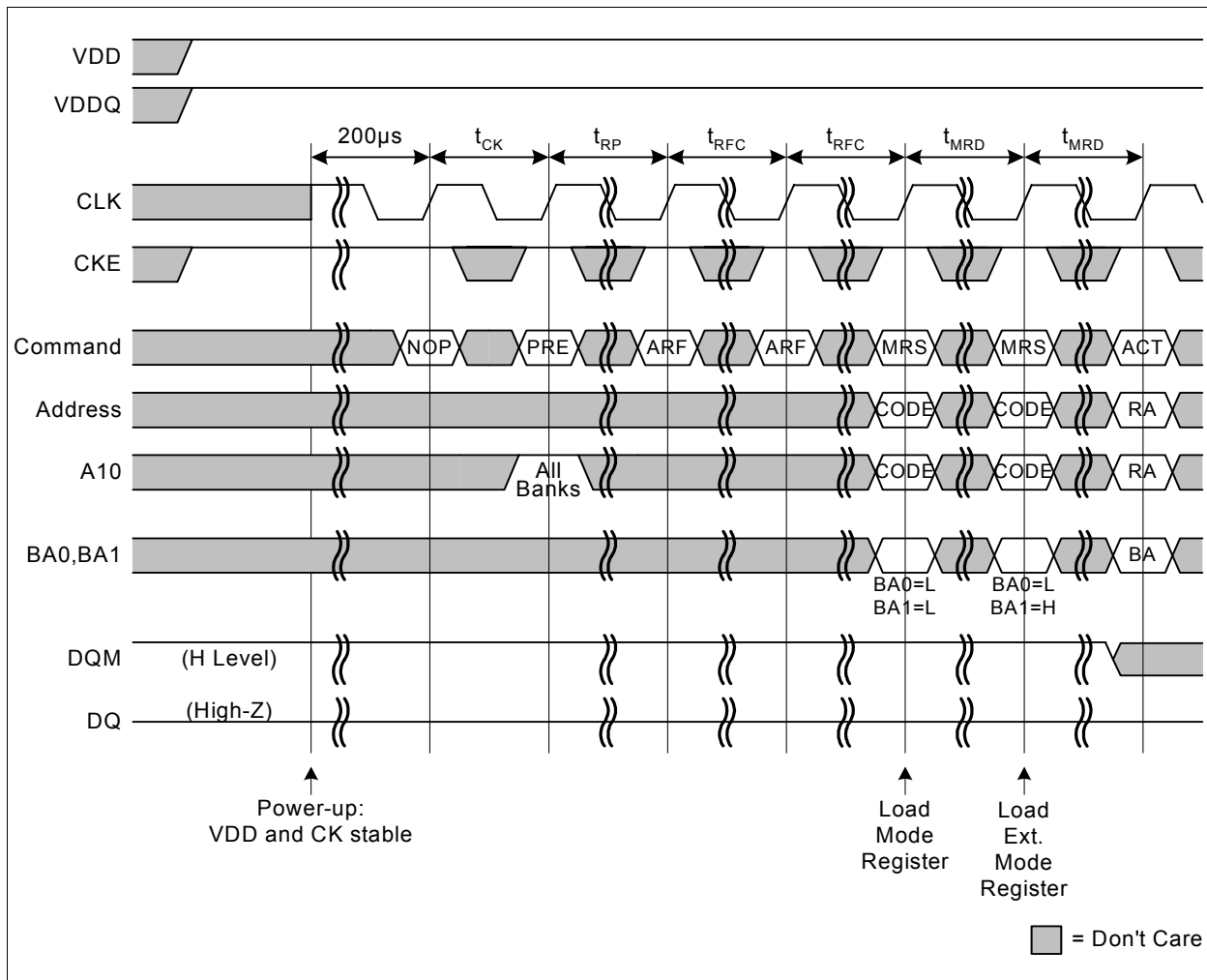

Figure 3 Power-Up Sequence and Mode Register Sets

Functional Description

1. At first, device core power (V_{DD}) and device IO power (V_{DDQ}) must be brought up simultaneously. Typically V_{DD} and V_{DDQ} are driven from a single power converter output. Assert and hold CKE and DQM to a HIGH level.
2. After V_{DD} and V_{DDQ} are stable and CKE is HIGH, apply stable clocks.
3. Wait for 200 μ s while issuing NOP or DESELECT commands.
4. Issue a PRECHARGE ALL command, followed by NOP or DESELECT commands for at least t_{RP} period.
5. Issue two AUTO REFRESH commands, each followed by NOP or DESELECT commands for at least t_{RFC} period.
6. Issue two MODE REGISTER SET commands for programming the Mode Register and Extended Mode Register, each followed by NOP or DESELECT commands for at least t_{MRD} period; the order in which both registers are programmed is not important.

Following these steps, the Mobile-RAM is ready for normal operation.

2.2 Register Definition

2.2.1 Mode Register

The Mode Register is used to define the specific mode of operation of the Mobile-RAM. This definition includes the selection of a burst length (bits A0-A2), a burst type (bit A3), a CAS latency (bits A4-A6), and a write burst mode (bit A9). The Mode Register is programmed via the MODE REGISTER SET command (with BA0 = 0 and BA1 = 0) and will retain the stored information until it is programmed again or the device loses power.

The Mode Register must be loaded when all banks are idle, and the controller must wait the specified time before initiating any subsequent operation. Violating either of these requirements results in unspecified operation.

Reserved states should not be used, as unknown operation or incompatibility with future versions may result.

MR

Mode Register Definition

(BA[1:0] = 00_B)

BA1	BA0	A12	A11	A10	A9	A8	A7	A6	A5	A4	A3	A2	A1	A0
0	0	0	0	0	WB	0	0		CL		BT			BL

Field	Bits	Type	Description
WB	9	w	Write Burst Mode 0 Burst Write 1 Single Write
CL	[6:4]	w	CAS Latency 010 2 011 3 <i>Note: All other bit combinations are RESERVED.</i>
BT	3	w	Burst Type 0 Sequential 1 Interleaved
BL	[2:0]	w	Burst Length 000 1 001 2 010 4 011 8 111 full page (Sequential burst type only) <i>Note: All other bit combinations are RESERVED.</i>

2.2.1.1 Burst Length

READ and WRITE accesses to the Mobile-RAM are burst oriented, with the burst length being programmable. The burst length determines the maximum number of column locations that can be accessed for a given READ or WRITE command. Burst lengths of 1, 2, 4, 8 locations are available for both the sequential and interleaved burst types, and a full-page burst mode is available for the sequential burst type.

When a READ or WRITE command is issued, a block of columns equal to the burst length is effectively selected. All accesses for that burst take place within this block, meaning that the burst wraps within the block if a boundary is reached. The block is uniquely selected by A1-A8 when the burst length is set to two, by A2-A8 when the burst length is set to four and by A3-A8 when the burst length is set to eight. The remaining (least significant) address bit(s) is (are) used to select the starting location within the block.

Full page bursts wrap within the page if the boundary is reached. Please note that full page bursts do not self-terminate; this implies that full-page read or write bursts with Auto Precharge are not legal commands.

Table 5 Burst Definition

Burst Length	Starting Column Address			Order of Accesses Within a Burst	
	A2	A1	A0	Sequential	Interleaved
2			0	0 - 1	0 - 1
			1	1 - 0	1 - 0
4		0	0	0 - 1 - 2 - 3	0 - 1 - 2 - 3
		0	1	1 - 2 - 3 - 0	1 - 0 - 3 - 2
		1	0	2 - 3 - 0 - 1	2 - 3 - 0 - 1
		1	1	3 - 0 - 1 - 2	3 - 2 - 1 - 0
8	0	0	0	0 - 1 - 2 - 3 - 4 - 5 - 6 - 7	0 - 1 - 2 - 3 - 4 - 5 - 6 - 7
	0	0	1	1 - 2 - 3 - 4 - 5 - 6 - 7 - 0	1 - 0 - 3 - 2 - 5 - 4 - 7 - 6
	0	1	0	2 - 3 - 4 - 5 - 6 - 7 - 0 - 1	2 - 3 - 0 - 1 - 6 - 7 - 4 - 5
	0	1	1	3 - 4 - 5 - 6 - 7 - 0 - 1 - 2	3 - 2 - 1 - 0 - 7 - 6 - 5 - 4
	1	0	0	4 - 5 - 6 - 7 - 0 - 1 - 2 - 3	4 - 5 - 6 - 7 - 0 - 1 - 2 - 3
	1	0	1	5 - 6 - 7 - 0 - 1 - 2 - 3 - 4	5 - 4 - 7 - 6 - 1 - 0 - 3 - 2
	1	1	0	6 - 7 - 0 - 1 - 2 - 3 - 4 - 5	6 - 7 - 4 - 5 - 2 - 3 - 0 - 1
	1	1	1	7 - 0 - 1 - 2 - 3 - 4 - 5 - 6	7 - 6 - 5 - 4 - 3 - 2 - 1 - 0
Full Page	n	n	n	Cn, Cn+1, Cn+2, ...	not supported

Notes

1. For a burst length of 2, A1-Ai select the two-data-element block; A0 selects the first access within the block.
2. For a burst length of 4, A2-Ai select the four-data-element block; A0-A1 select the first access within the block.
3. For a burst length of 8, A3-Ai select the eight-data-element block; A0-A2 select the first access within the block.
4. For a full page burst, A0-Ai select the starting data element.
5. Whenever a boundary of the block is reached within a given sequence, the following access wraps within the block.

2.2.1.2 Burst Type

Accesses within a given burst may be programmed to be either sequential or interleaved; this is referred to as the burst type and is selected via bit A3. The ordering of accesses within a burst is determined by the burst length, the burst type and the starting column address, as shown in [Table 5](#).

2.2.1.3 Read Latency

The Read latency, or CAS latency, is the delay, in clock cycles, between the registration of a READ command and the availability of the first piece of output data. The latency can be programmed to 2 or 3 clocks.

If a READ command is registered at clock edge n , and the latency is m clocks, the data will be available with clock edge $n + m$ (for details please refer to the READ command description).

2.2.1.4 Write Burst Mode

When $A9 = 0$, the burst length programmed via $A0-A2$ applies to both read and write bursts; when $A9 = 1$, write accesses consist of single data elements only.

2.2.1.5 Extended Mode Register

The Extended Mode Register controls additional low power features of the device. These include the Partial Array Self Refresh (PASR, bits $A0-A2$), the Temperature Compensated Self Refresh (TCSR, bits $A3-A4$) and the drive strength selection for the DQs (bits $A5-A6$). The Extended Mode Register is programmed via the MODE REGISTER SET command (with $BA0 = 0$ and $BA1 = 1$) and will retain the stored information until it is programmed again or the device loses power.

The Extended Mode Register must be loaded when all banks are idle, and the controller must wait the specified time before initiating any subsequent operation. Violating either of these requirements result in unspecified operation.

Reserved states should not be used, as unknown operation or incompatibility with future versions may result.

EMR

Extended Mode Register

($BA[1:0] = 10_B$)

BA1	BA0	A12	A11	A10	A9	A8	A7	A6	A5	A4	A3	A2	A1	A0
1	0	0	0	0	0	0	0	DS		(TCSR)			PASR	

Field	Bits	Type	Description
DS	[6:5]	w	Selectable Drive Strength 00 Full Drive Strength 01 Half Drive Strength <i>Note: All other bit combinations are RESERVED.</i>
TCSR	[4:3]	w	Temperature Compensated Self Refresh XX Superseded by on-chip temperature sensor (see text)
PASR	[2:0]	w	Partial Array Self Refresh 000 all banks 001 1/2 array ($BA1 = 0$) 010 1/4 array ($BA1 = BA0 = 0$) 101 1/8 array ($BA1 = BA0 = RA12 = 0$) 110 1/16 array ($BA1 = BA0 = RA12 = RA11 = 0$) <i>Note: All other bit combinations are RESERVED.</i>

2.2.1.6 Partial Array Self Refresh (PASR)

Partial Array Self Refresh is a power-saving feature specific to Mobile RAMs. With PASR, self refresh may be restricted to variable portions of the total array. The selection comprises all four banks (default), two banks, one bank, half of one bank, and a quarter of one bank. Data written to the non activated memory sections will get lost after a period defined by t_{REF} (cf. [Table 13](#)).

2.2.1.7 Temperature Compensated Self Refresh (TCSR) with On-Chip Temperature Sensor

DRAM devices store data as electrical charge in tiny capacitors that require a periodic refresh in order to retain the stored information. This refresh requirement heavily depends on the die temperature: high temperatures correspond to short refresh periods, and low temperatures correspond to long refresh periods.

The Mobile-RAM is equipped with an on-chip temperature sensor which continuously senses the actual die temperature and adjusts the refresh period in Self Refresh mode accordingly. This makes any programming of the TCSR bits in the Extended Mode Register obsolete. It also is the superior solution in terms of compatibility and power-saving, because

- it is fully compatible to all processors that do not support the Extended Mode Register
- it is fully compatible to all applications that only write a default (worst case) TCSR value, e.g. because of the lack of an external temperature sensor
- it does not require any processor interaction for regular TCSR updates

2.2.1.8 Selectable Drive Strength

The drive strength of the DQ output buffers is selectable via bits A5 and A6. The default value ("half drive strength") is suitable for typical applications of a Mobile-RAM. For heavier loaded systems, a stronger output buffer ("full drive strength") is available. I - V curves for the full drive strength and half drive strength are included in this document.

2.3 State Diagram

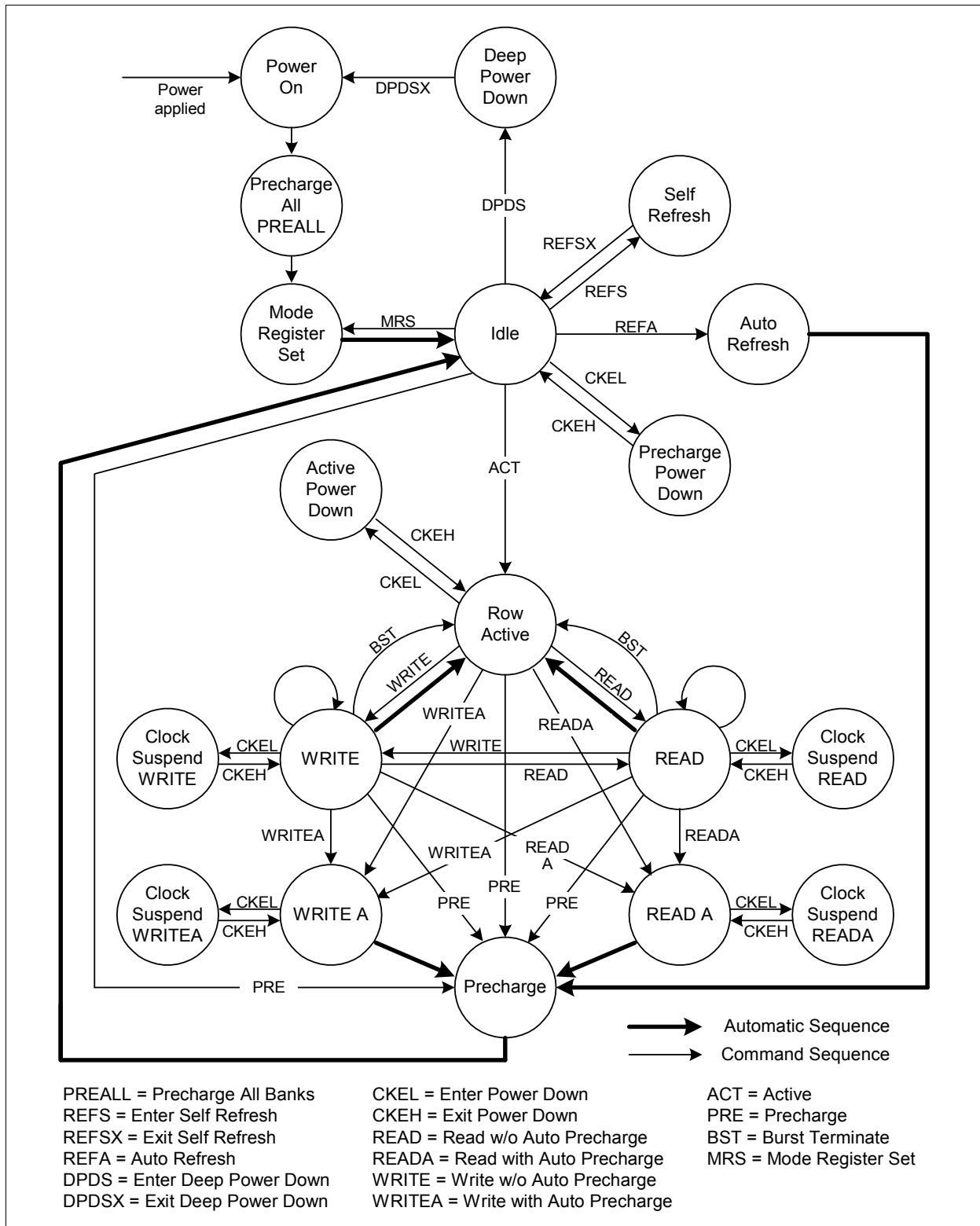

Figure 4 State Diagram

2.4 Commands

Table 6 Command Overview

Command		CS	RAS	CAS	WE	DQM	Address	Notes
NOP	DESELECT	H	X	X	X	X	X	1)
	NO OPERATION	L	H	H	H	X	X	1)
ACT	ACTIVE (Select bank and row)	L	L	H	H	X	Bank / Row	2)
RD	READ (Select bank and column and start read burst)	L	H	L	H	L/H	Bank / Col	3)
WR	WRITE (Select bank and column and start write burst)	L	H	L	L	L/H	Bank / Col	3)
BST	BURST TERMINATE or DEEP POWER DOWN	L	H	H	L	X	X	4)
PRE	PRECHARGE (Deactivate row in bank or banks)	L	L	H	L	X	Code	5)
ARF	AUTO REFRESH or SELF REFRESH (enter self refresh mode)	L	L	L	H	X	X	6)7)
MRS	MODE REGISTER SET	L	L	L	L	X	Op-Code	8)
-	Data Write / Output Enable	-	-	-	-	L	-	9)
-	Write Mask / Output Disable (High-Z)	-	-	-	-	H	-	9)

- 1) Deselect and NOP are functionally interchangeable.
- 2) BA0, BA1 provide bank address, and A0 - A12 provide row address.
- 3) BA0, BA1 provide bank address, A0 - A8 provide column address; A10 HIGH enables the Auto Precharge feature (nonpersistent), A10 LOW disables the Auto Precharge feature.
- 4) This command is BURST TERMINATE if CKE is HIGH, DEEP POWER DOWN if CKE is LOW. The BURST TERMINATE command is defined for READ or WRITE bursts with Auto Precharge disabled only.
- 5) A10 LOW: BA0, BA1 determine which bank is precharged.
A10 HIGH: all banks are precharged and BA0, BA1 are "Don't Care".
- 6) This command is AUTO REFRESH if CKE is HIGH, SELF REFRESH if CKE is LOW.
- 7) Internal refresh counter controls row and bank addressing; all inputs and I/Os are "Don't Care" except for CKE.
- 8) BA0, BA1 select either the Mode Register (BA0 = 0, BA1 = 0) or the Extended Mode Register (BA0 = 0, BA1 = 1); other combinations of BA0, BA1 are reserved; A0 - A12 provide the op-code to be written to the selected mode register.
- 9) DQM LOW: data present on DQs is written to memory during write cycles; DQ output buffers are enabled during read cycles;
DQM HIGH: data present on DQs are masked and thus not written to memory during write cycles; DQ output buffers are placed in High-Z state (two clocks latency) during read cycles.

Address (A0 - A12, BA0, BA1), write data (DQ0 - DQ15) and command inputs (CKE, CS, RAS, CAS, WE, DQM) are all registered on the positive edge of CLK. **Figure 5** shows the basic timing parameters, which apply to all commands and operations.

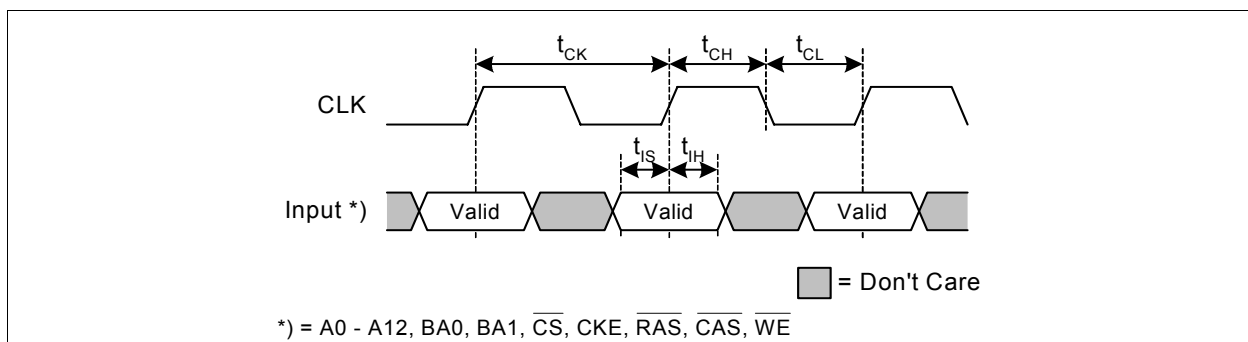

Figure 5 Address / Command Inputs Timing Parameters

Table 7 Inputs Timing Parameters

Parameter	Symbol	- 7.5		Unit	Notes	
		min.	max.			
Clock cycle time	CL = 3	t_{CK}	7.5	–	ns	–
	CL = 2		9.5	–	ns	
Clock frequency	CL = 3	f_{CK}	–	133	MHz	–
	CL = 2		–	105	MHz	
Clock high-level width		t_{CH}	2.5	–	ns	–
Clock low-level width		t_{CL}	2.5	–	ns	–
Address and command input setup time		t_{IS}	1.5	–	ns	–
Address and command input hold time		t_{IH}	0.8	–	ns	–

2.4.1 NO OPERATION (NOP)

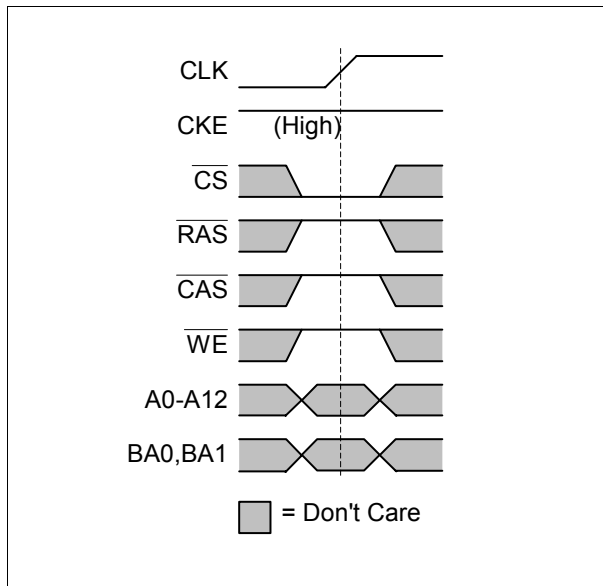

Figure 6 No Operation Command

The NO OPERATION (NOP) command is used to perform a NOP to a Mobile-RAM which is selected ($\overline{CS} = \text{LOW}$). This prevents unwanted commands from being registered during idle states. Operations already in progress are not affected.

2.4.2 DESELECT

The DESELECT function ($\overline{CS} = \text{HIGH}$) prevents new commands from being executed by the Mobile-RAM. The Mobile-RAM is effectively deselected. Operations already in progress are not affected.

2.4.3 MODE REGISTER SET

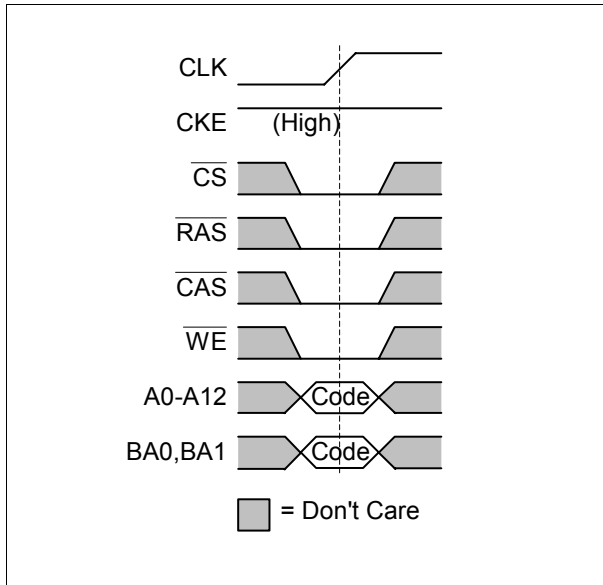

The Mode Register and Extended Mode Register are loaded via inputs A0 - A12 (see mode register descriptions in [Chapter 2.2](#)). The MODE REGISTER SET command can only be issued when all banks are idle and no bursts are in progress. A subsequent executable command cannot be issued until t_{MRD} is met.

Figure 7 Mode Register Set Command

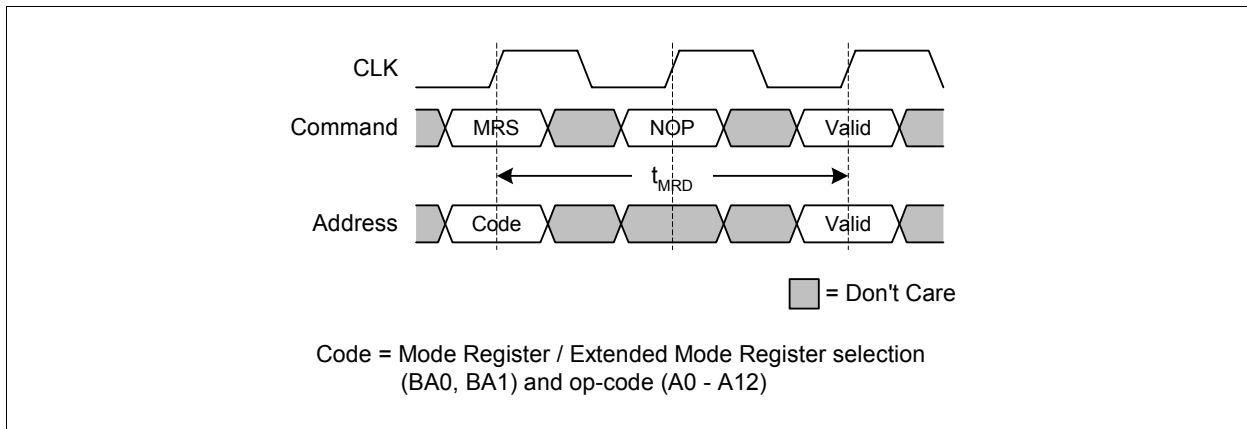
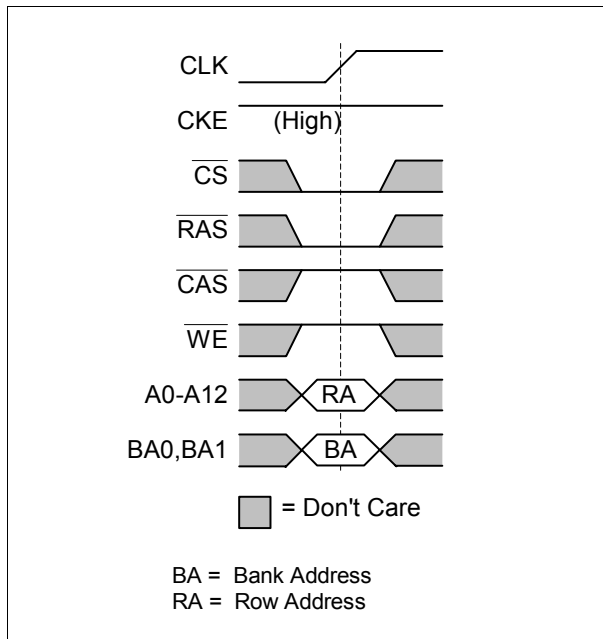

Figure 8 Mode Register Definition

Table 8 Timing Parameters for Mode Register Set Command

Parameter	Symbol	- 7.5		Units	Notes
		min.	max.		
MODE REGISTER SET command period	t_{MRD}	2	-	t_{CK}	-

2.4.4 ACTIVE



Before any READ or WRITE commands can be issued to a bank within the Mobile-RAM, a row in that bank must be “opened” (activated). This is accomplished via the ACTIVE command and addresses A0 - A12, BA0 and BA1 (see [Figure 9](#)), which decode and select both the bank and the row to be activated. After opening a row (issuing an ACTIVE command), a READ or WRITE command may be issued to that row, subject to the t_{RCD} specification. A subsequent ACTIVE command to a different row in the same bank can only be issued after the previous active row has been “closed” (precharged).

The minimum time interval between successive ACTIVE commands to the same bank is defined by t_{RC} . A subsequent ACTIVE command to another bank can be issued while the first bank is being accessed, which results in a reduction of total row-access overhead. The minimum time interval between successive ACTIVE commands to different banks is defined by t_{RRD} .

Figure 9 ACTIVE Command

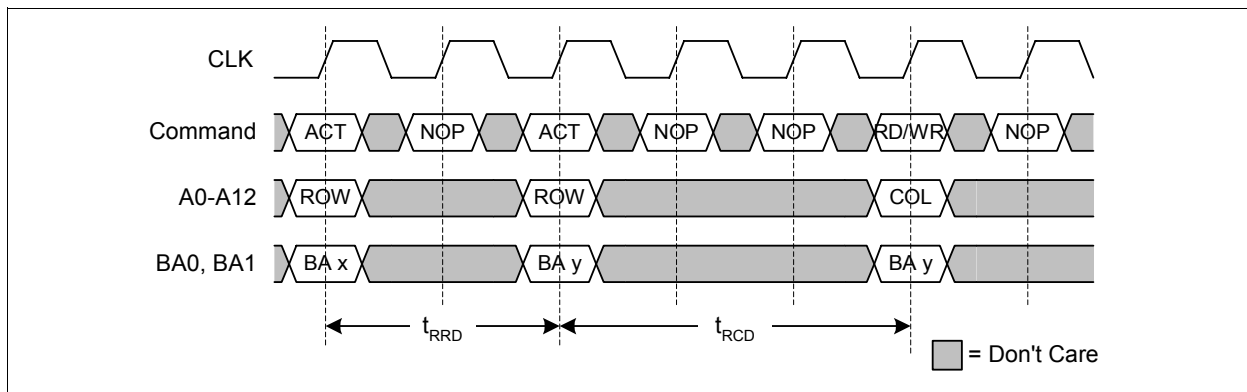

Figure 10 Bank Activate Timings

Table 9 Timing Parameters for ACTIVE Command

Parameter	Symbol	- 7.5		Units	Notes
		min.	max.		
ACTIVE to ACTIVE command period	t_{RC}	67	–	ns	1)
ACTIVE to READ or WRITE delay	t_{RCD}	19	–	ns	1)
ACTIVE bank A to ACTIVE bank B delay	t_{RRD}	15	–	ns	1)

1) These parameters account for the number of clock cycles and depend on the operating frequency as follows:
 no. of clock cycles = specified delay / clock period; round up to next integer.

2.4.5 READ

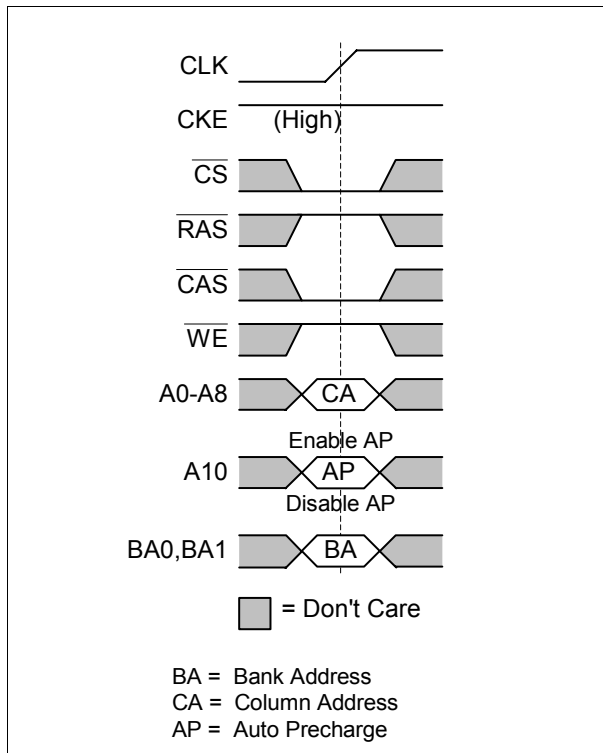

Figure 11 READ Command

Subsequent to programming the mode register with CAS latency and burst length, READ bursts are initiated with a READ command, as shown in **Figure 11**. Basic timings for the DQs are shown in **Figure 12**; they apply to all read operations and therefore are omitted from all subsequent timing diagrams.

The starting column and bank addresses are provided with the READ command and Auto Precharge is either enabled or disabled for that burst access. If Auto Precharge is enabled, the row being accessed starts precharge at the completion of the burst, provided t_{RAS} has been satisfied. For the generic READ commands used in the following illustrations, Auto Precharge is disabled.

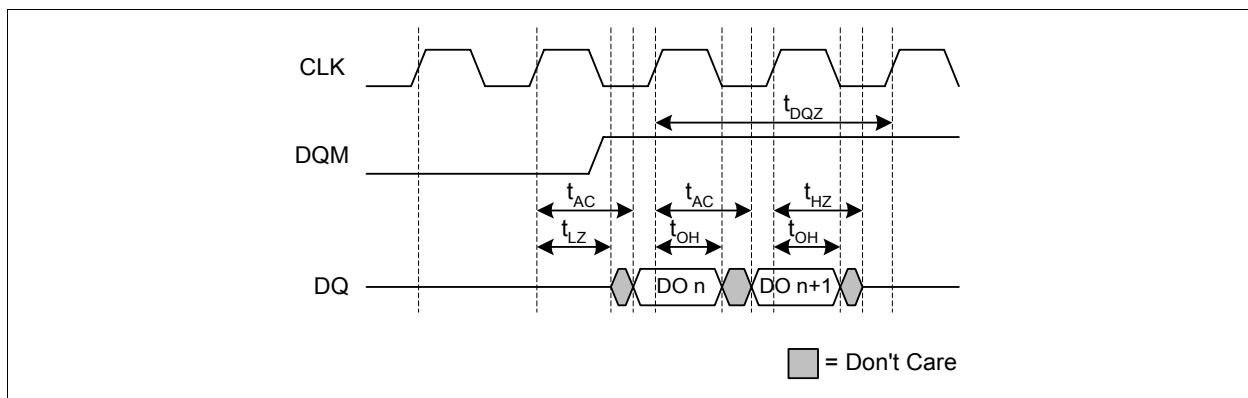

Figure 12 Basic READ Timing Parameters for DQs

Table 10 Timing Parameters for READ

Parameter	Symbol	- 7.5		Units	Notes	
		min.	max.			
Access time from CLK	CL = 3	t_{AC}	–	5.4	ns	–
	CL = 2	t_{AC}	–	6.0	ns	–
DQ low-impedance time from CLK		t_{LZ}	1.0	–	ns	–
DQ high-impedance time from CLK		t_{HZ}	3.0	7.0	ns	–
Data out hold time		t_{OH}	2.5	–	ns	–
DQM to DQ High-Z delay (READ Commands)		t_{DQZ}	–	2	t_{CK}	–
ACTIVE to ACTIVE command period		t_{RC}	67	–	ns	1)
ACTIVE to READ or WRITE delay		t_{RCD}	19	–	ns	1)
ACTIVE to PRECHARGE command period		t_{RAS}	45	100k	ns	1)
PRECHARGE command period		t_{RP}	19	–	ns	1)

1) These parameters account for the number of clock cycles and depend on the operating frequency as follows:
 no. of clock cycles = specified delay / clock period; round up to next integer.

During READ bursts, the valid data-out element from the starting column address is available following the CAS latency after the READ command. Each subsequent data-out element is valid nominally at the next positive clock edge. Upon completion of a READ burst, assuming no other READ command has been initiated, the DQs go to High-Z state.

Figure 13 and Figure 14 show single READ bursts for each supported CAS latency setting.

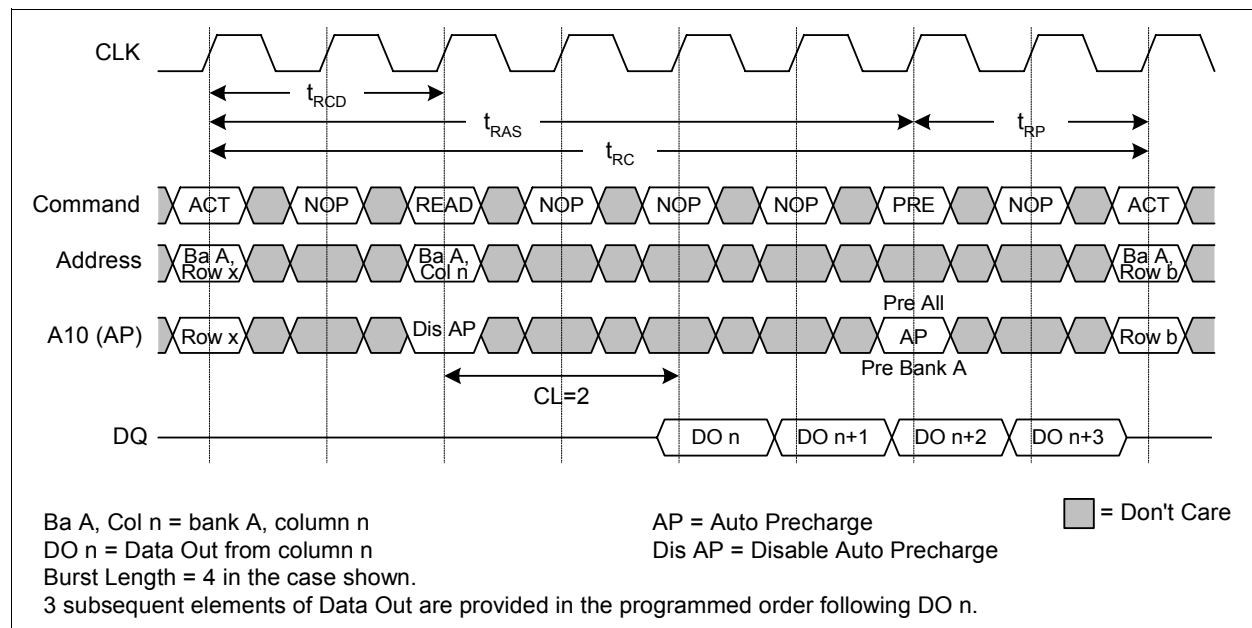

Figure 13 Single READ Burst (CAS Latency = 2)

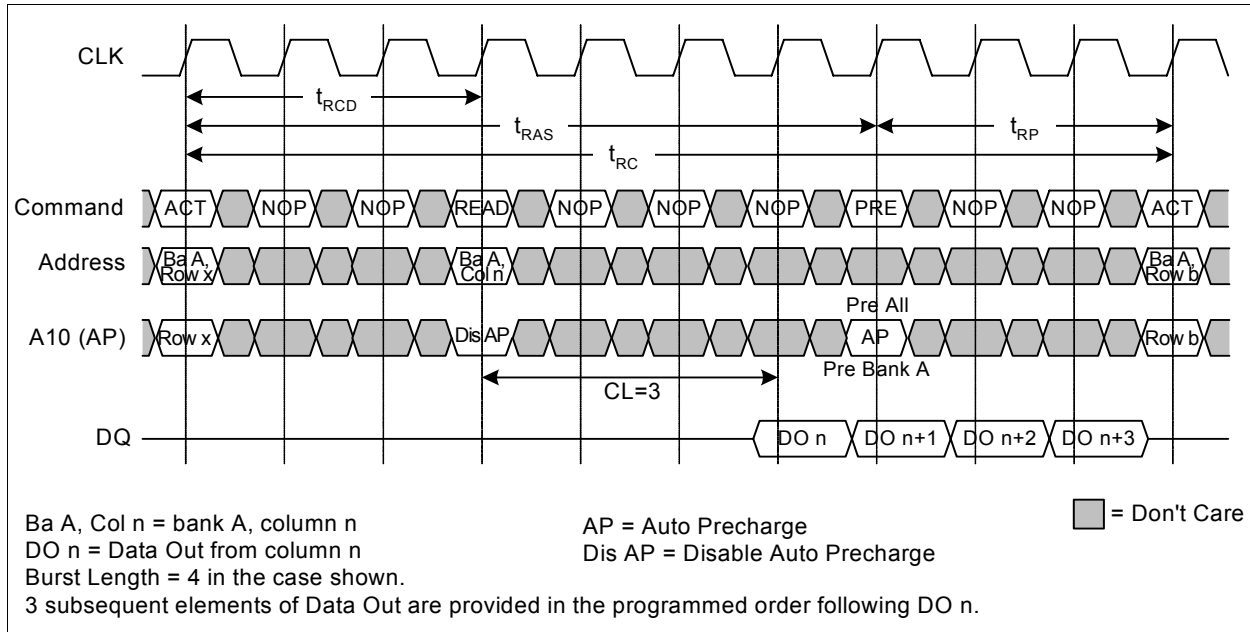

Figure 14 Single READ Burst (CAS Latency = 3)

Data from any READ burst may be concatenated with data from a subsequent READ command. In either case, a continuous flow of data can be maintained. A READ command can be initiated on any clock cycle following a previous READ command, and may be performed to the same or a different (active) bank. The first data element from the new burst follows either the last element of a completed burst (Figure 15) or the last desired data element of a longer burst which is being truncated (Figure 16). The new READ command should be issued x cycles after the first READ command, where x equals the number of desired data elements.

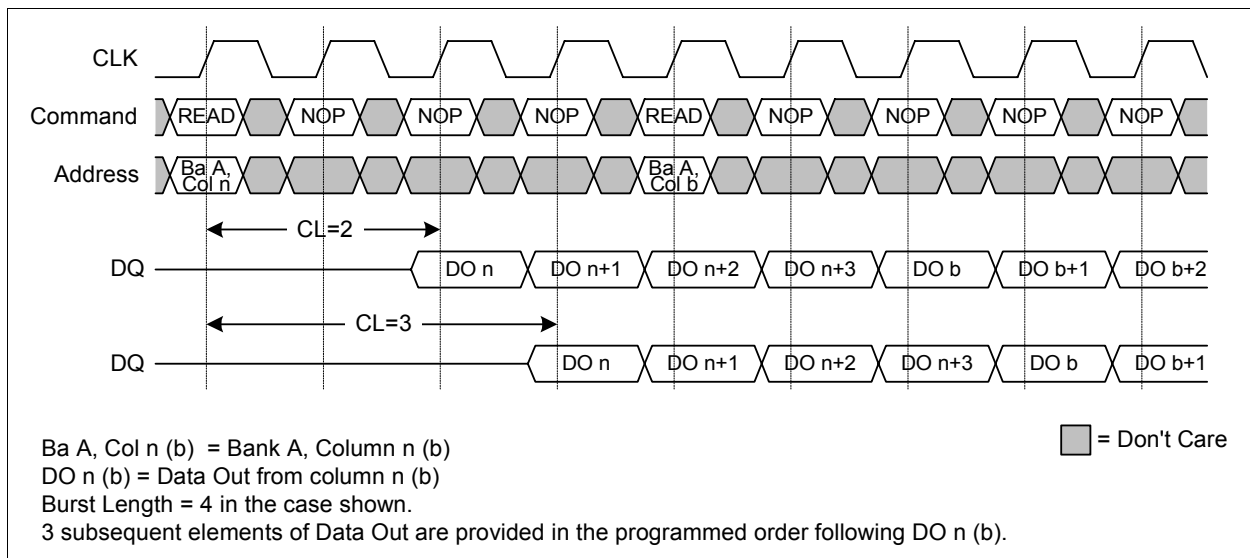

Figure 15 Consecutive READ Bursts

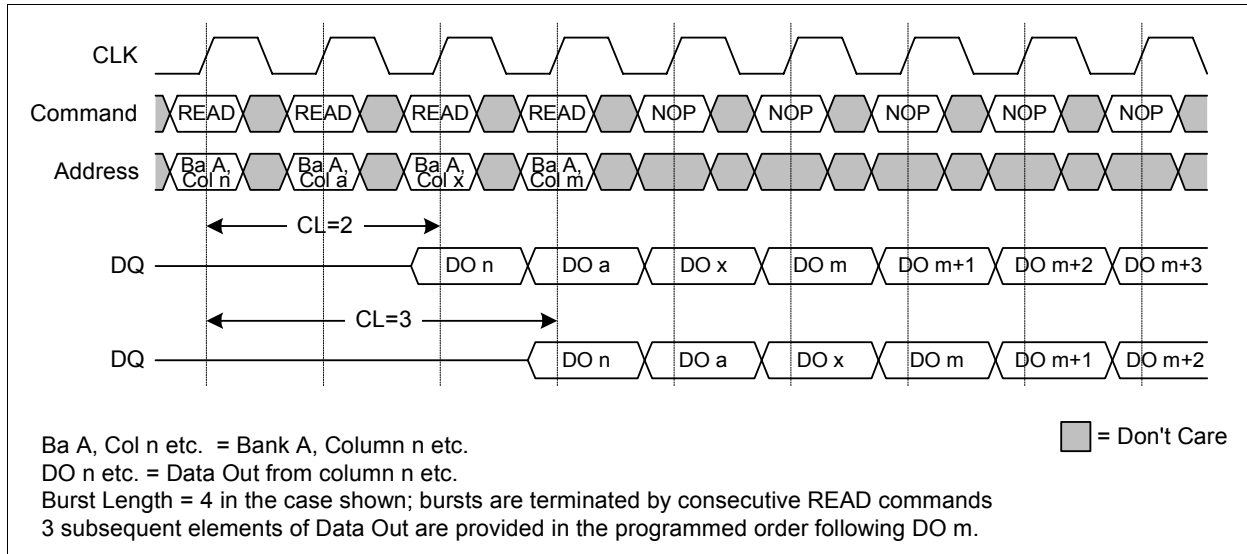

Figure 16 Random READ Bursts

Non-consecutive READ bursts are shown in [Figure 17](#).

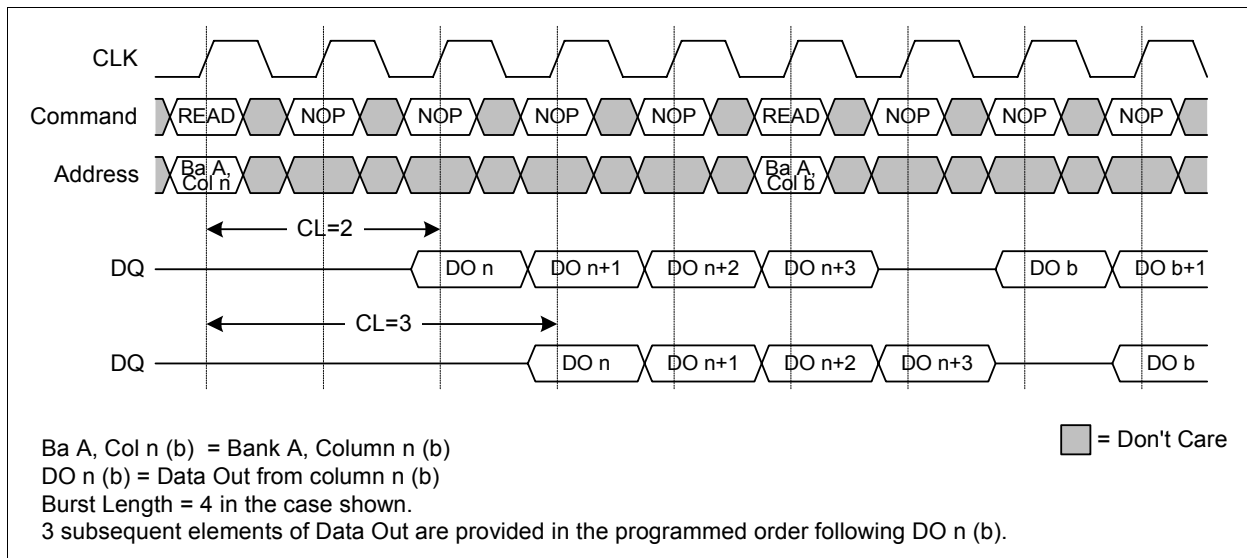

Figure 17 Non-Consecutive READ Bursts

2.4.5.1 READ Burst Termination

Data from any READ burst may be truncated using the BURST TERMINATE command (see [Page 33](#)), provided that Auto Precharge was not activated. The BURST TERMINATE latency is equal to the CAS latency, i.e. the BURST TERMINATE command must be issued x clock cycles before the clock edge at which the last desired data element is valid, where x equals the CAS latency for READ bursts minus 1. This is shown in [Figure 18](#). The BURST TERMINATE command may be used to terminate a full-page READ which does not self-terminate.

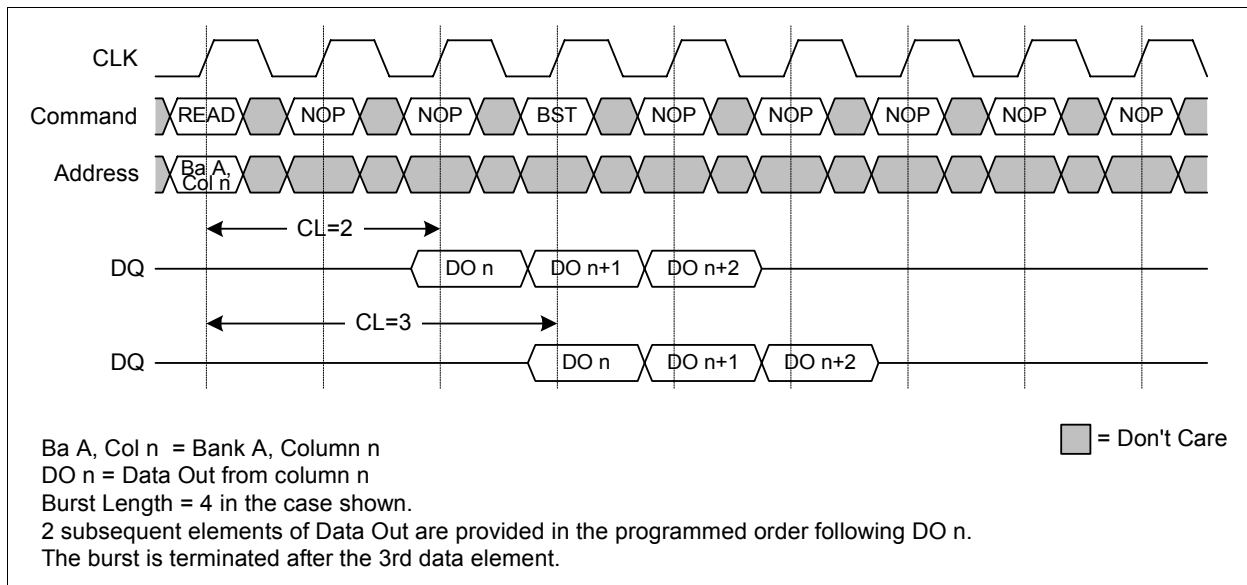

Figure 18 Terminating a READ Burst

2.4.5.2 Clock Suspend Mode for READ Cycles

Clock suspend mode allows to extend any read burst in progress by a variable number of clock cycles. As long as CKE is registered LOW, the following internal clock pulse(s) will be ignored and data on DQ will remain driven, as shown in [Figure 19](#).

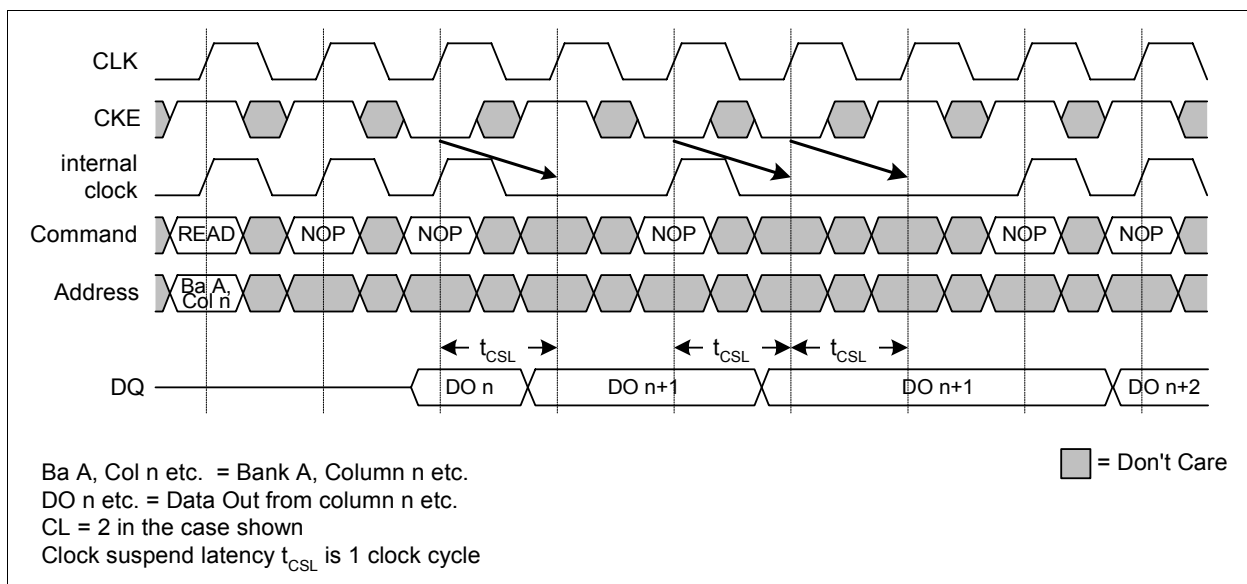

Figure 19 Clock Suspend Mode for READ Bursts

2.4.5.3 READ - DQM Operation

DQM may be used to suppress read data and place the output buffers into High-Z state. The generic timing parameters as listed in [Table 10](#) also apply to this DQM operation. The read burst in progress is not affected and will continue as programmed.

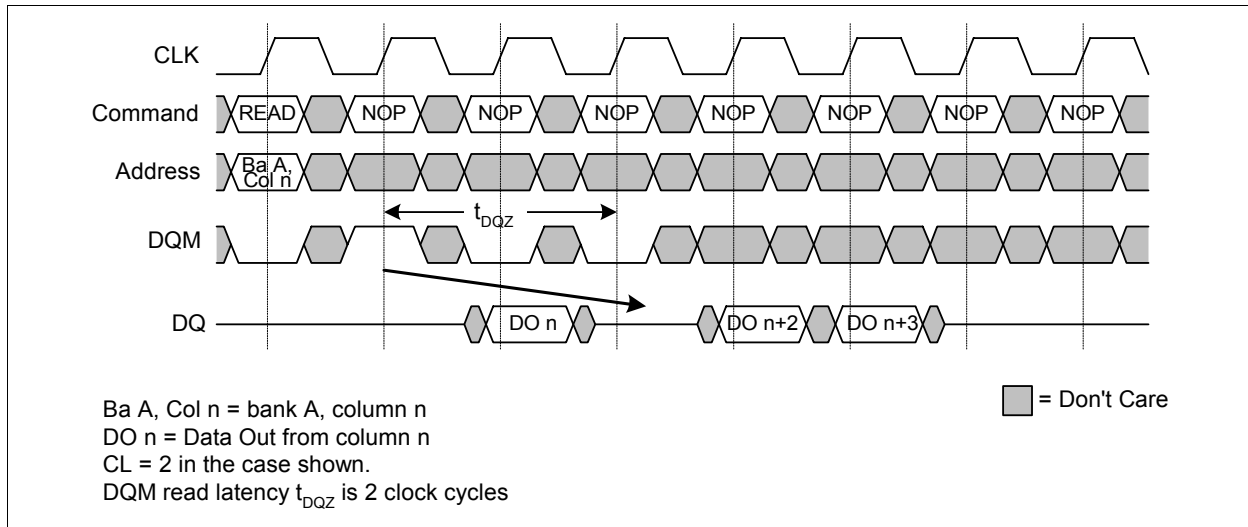

Figure 20 READ Burst - DQM Operation

2.4.5.4 READ to WRITE

A READ burst may be followed by or truncated with a WRITE command. The WRITE command can be performed to the same or a different (active) bank. Care must be taken to avoid bus contention on the DQs; therefore it is recommended that the DQs are held in High-Z state for a minimum of 1 clock cycle. This can be achieved by either delaying the WRITE command, or suppressing the data-out from the READ by pulling DQM HIGH two clock cycles prior to the WRITE command, as shown in [Figure 21](#). With the registration of the WRITE command, DQM acts as a write mask: when asserted HIGH, input data will be masked and no write will be performed.

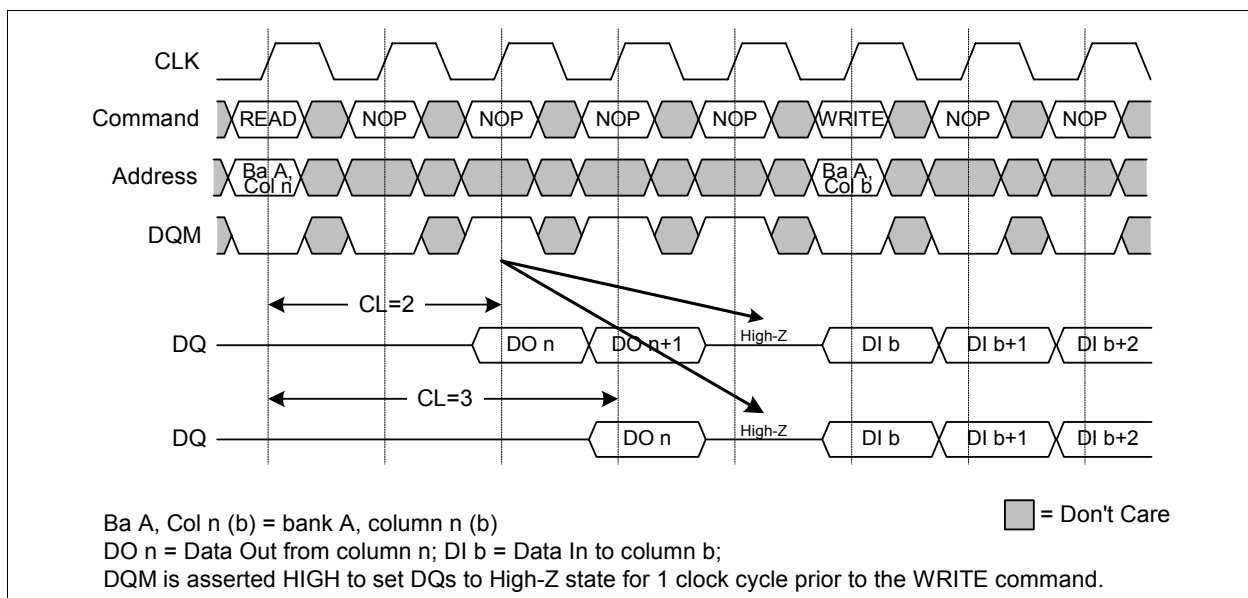

Figure 21 READ to WRITE Timing

2.4.5.5 READ to PRECHARGE

A READ burst may be followed by, or truncated with a PRECHARGE command to the same bank, provided that Auto Precharge was not activated. This is shown in **Figure 22**.

The PRECHARGE command should be issued x clock cycles before the clock edge at which the last desired data element is valid, where x equals the CAS latency for READ bursts minus 1. Following the PRECHARGE command, a subsequent ACTIVE command to the same bank cannot be issued until t_{RP} is met. Please note that part of the row precharge time is hidden during the access of the last data elements.

In the case of a READ being executed to completion, a PRECHARGE command issued at the optimum time (as described above) provides the same operation that would result from the same READ burst with Auto Precharge enabled. The disadvantage of the PRECHARGE command is that it requires that the command and address busses be available at the appropriate time to issue the command. The advantage of the PRECHARGE command is that it can be used to truncate bursts.

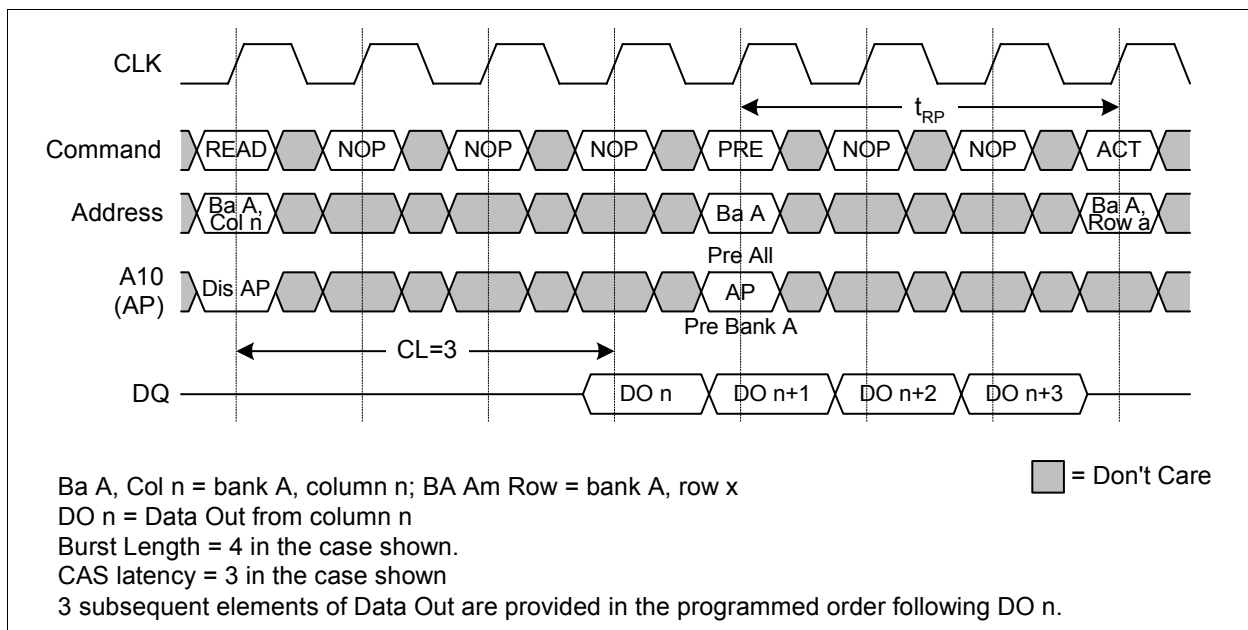

Figure 22 READ to PRECHARGE Timing

2.4.6 WRITE

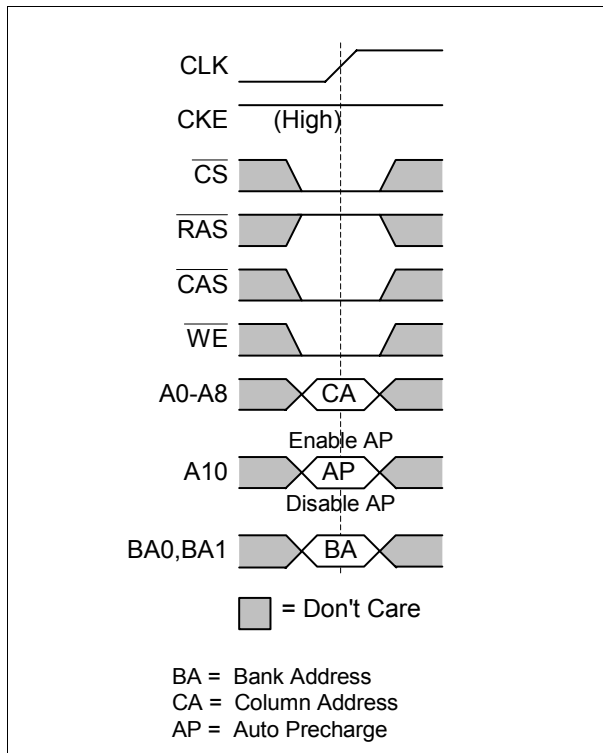

Figure 23 WRITE Command

WRITE bursts are initiated with a WRITE command, as shown in [Figure 23](#). Basic timings for the DQs are shown in [Figure 24](#); they apply to all write operations.

The starting column and bank addresses are provided with the WRITE command, and Auto Precharge is either enabled or disabled for that access. If Auto Precharge is enabled, the row being accessed is precharged at the completion of the write burst. For the generic WRITE commands used in the following illustrations, Auto Precharge is disabled.

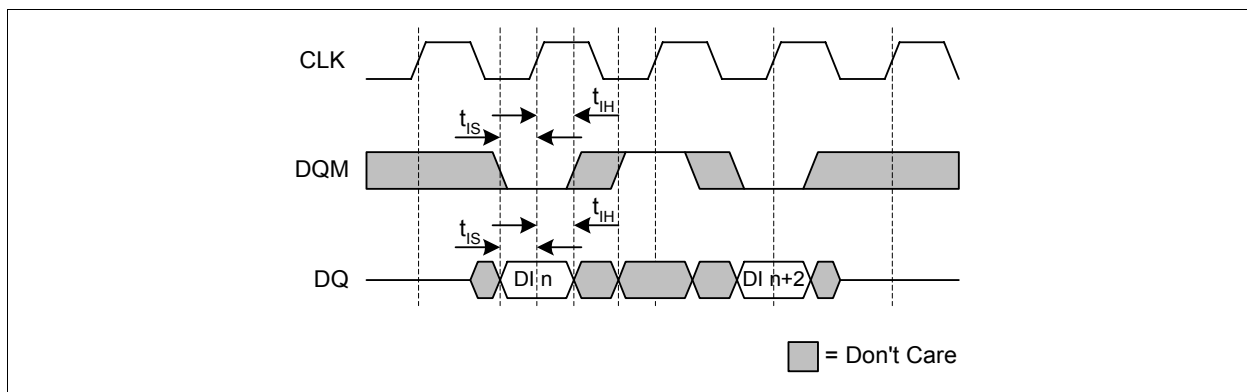

Figure 24 Basic WRITE Timing Parameters for DQs

During WRITE bursts, the first valid data-in element is registered coincident with the WRITE command, and subsequent data elements are registered on each successive positive edge of CLK. Upon completion of a burst, assuming no other commands have been initiated, the DQs remain in High-Z state, and any additional input data is ignored.

[Figure 25](#) and [Figure 26](#) show a single WRITE burst for each supported CAS latency setting.

Table 11 Timing Parameters for WRITE

Parameter	Symbol	- 7.5		Units	Notes
		min.	max.		
DQ and DQM input setup time	t_{IS}	1.5	–	ns	–
DQ and DQM input hold time	t_{IH}	0.8	–	ns	–
DQM write mask latency	t_{DQW}	0	–	t_{CK}	–
ACTIVE to ACTIVE command period	t_{RC}	67	–	ns	1)
ACTIVE to READ or WRITE delay	t_{RCD}	19	–	ns	1)
ACTIVE to PRECHARGE command period	t_{RAS}	45	100k	ns	1)
WRITE recovery time	t_{WR}	14	–	ns	1)
PRECHARGE command period	t_{RP}	19	–	ns	1)

1) These parameters account for the number of clock cycles and depend on the operating frequency as follows:
 no. of clock cycles = specified delay / clock period; round up to next integer.

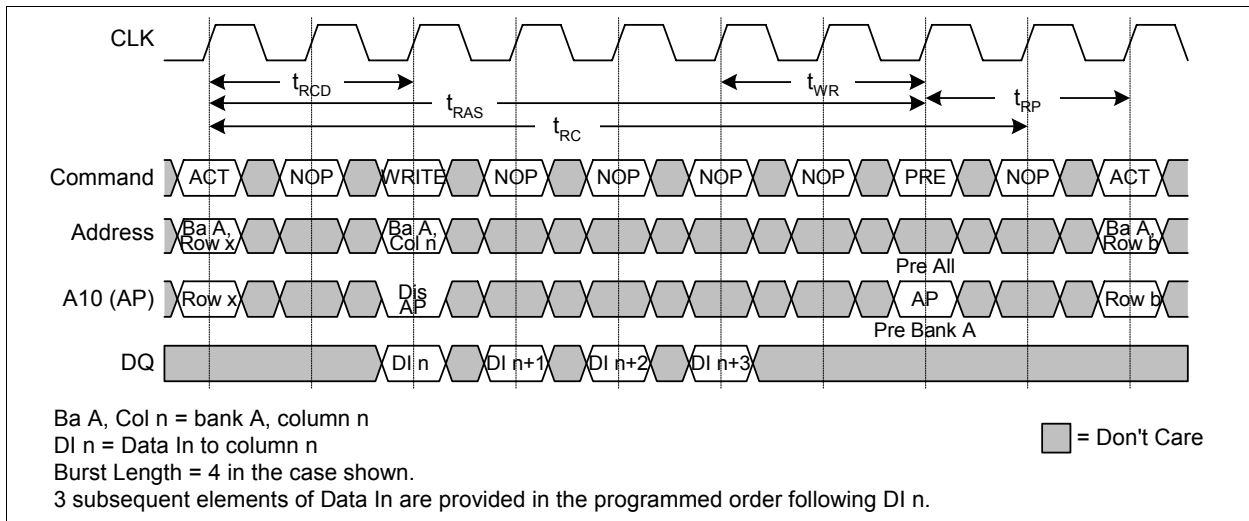

Figure 25 WRITE Burst (CAS Latency = 2)

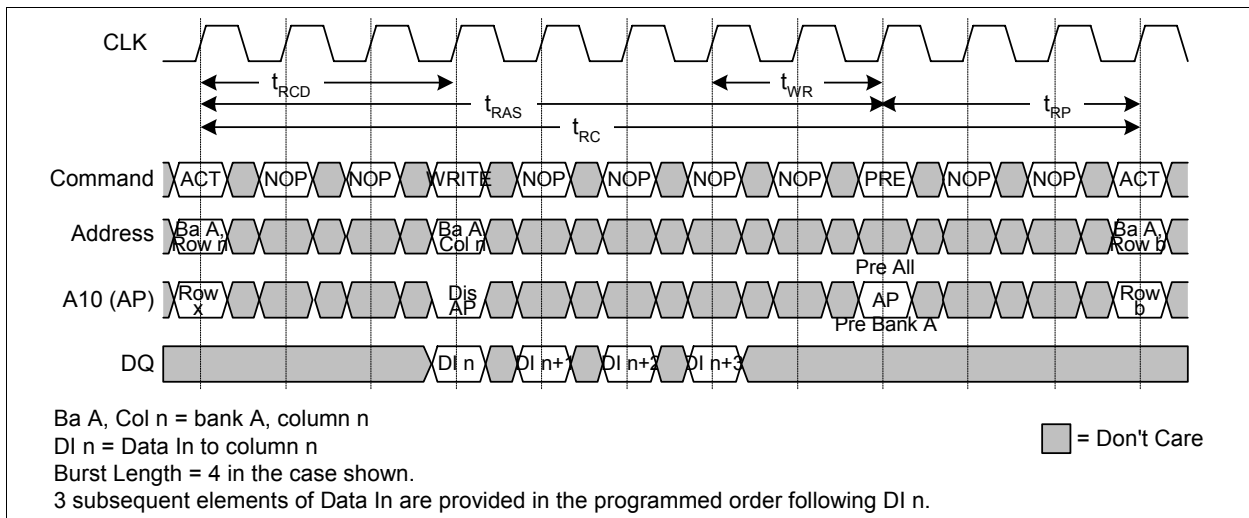

Figure 26 WRITE Burst (CAS Latency = 3)

Functional Description

Data for any WRITE burst may be concatenated with or truncated with a subsequent WRITE command. In either case, a continuous flow of input data can be maintained. A WRITE command can be issued on any positive edge of clock following the previous WRITE command. The first data element from the new burst is applied after either the last element of a completed burst (Figure 27) or the last desired data element of a longer burst which is being truncated (Figure 28). The new WRITE command should be issued x cycles after the first WRITE command, where x equals the number of desired data elements.

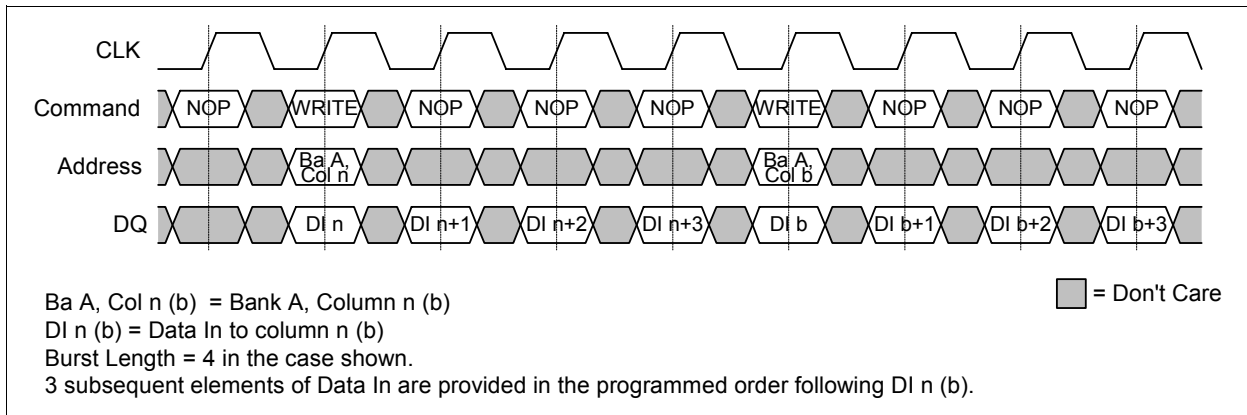

Figure 27 Consecutive WRITE Bursts

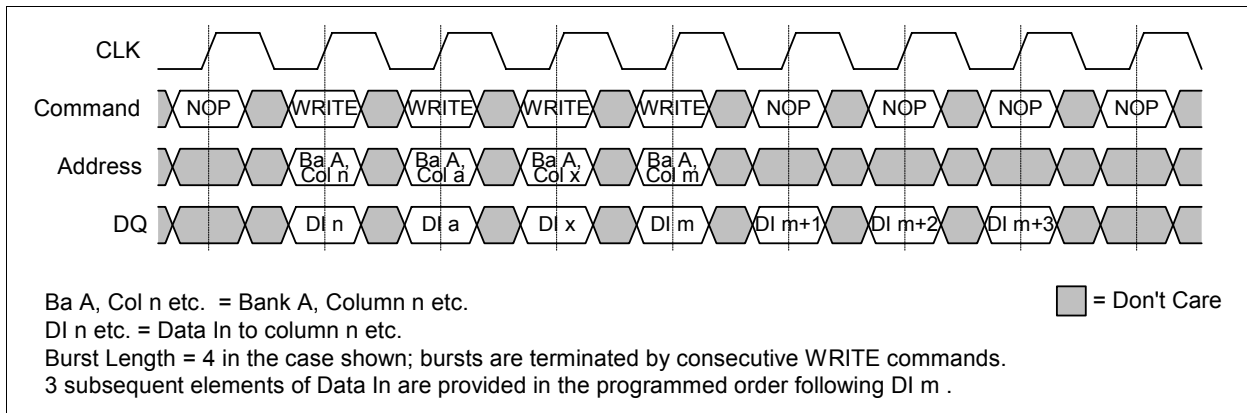

Figure 28 Random WRITE Bursts

Non-consecutive WRITE bursts are shown in Figure 29.

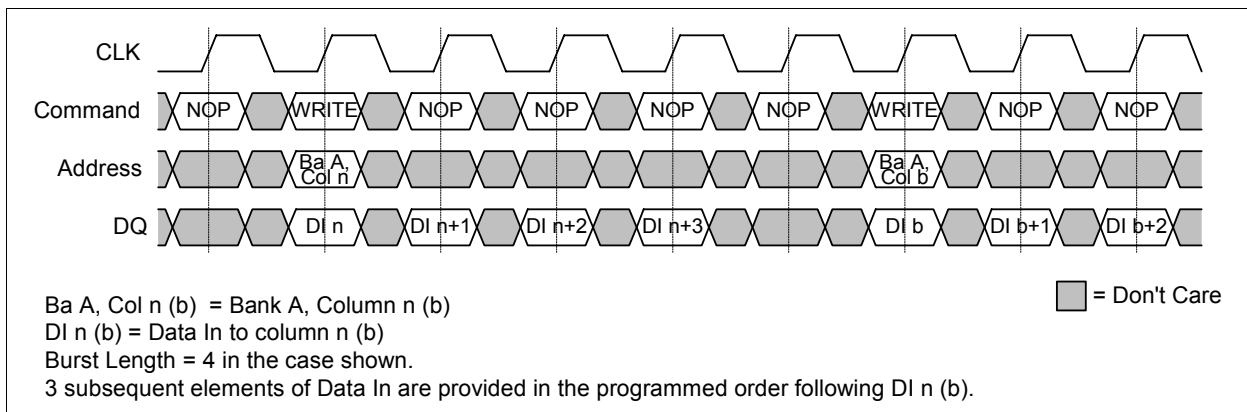

Figure 29 Non-Consecutive WRITE Bursts

2.4.6.1 WRITE Burst Termination

Data from any WRITE burst may be truncated using the BURST TERMINATE command (see [Page 33](#)), provided that Auto Precharge was not activated. The input data provided coincident with the BURST TERMINATE command will be ignored. This is shown in [Figure 30](#). The BURST TERMINATE command may be used to terminate a full-page WRITE which does not self-terminate.

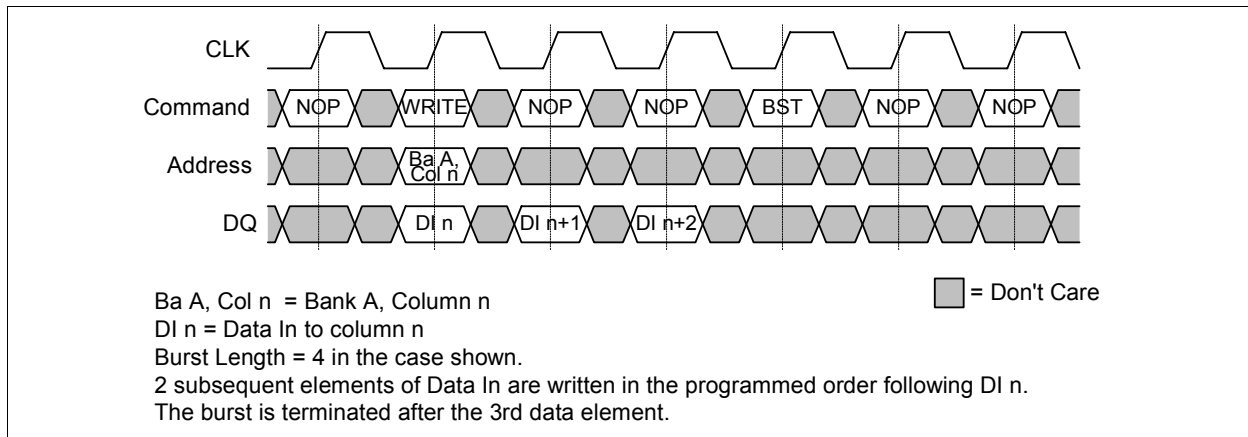

Figure 30 Terminating a WRITE Burst

2.4.6.2 Clock Suspend Mode for WRITE Cycles

Clock suspend mode allows to extend any WRITE burst in progress by a variable number of clock cycles. As long as CKE is registered LOW, the following internal clock pulse(s) will be ignored and no data will be captured, as shown in [Figure 31](#).

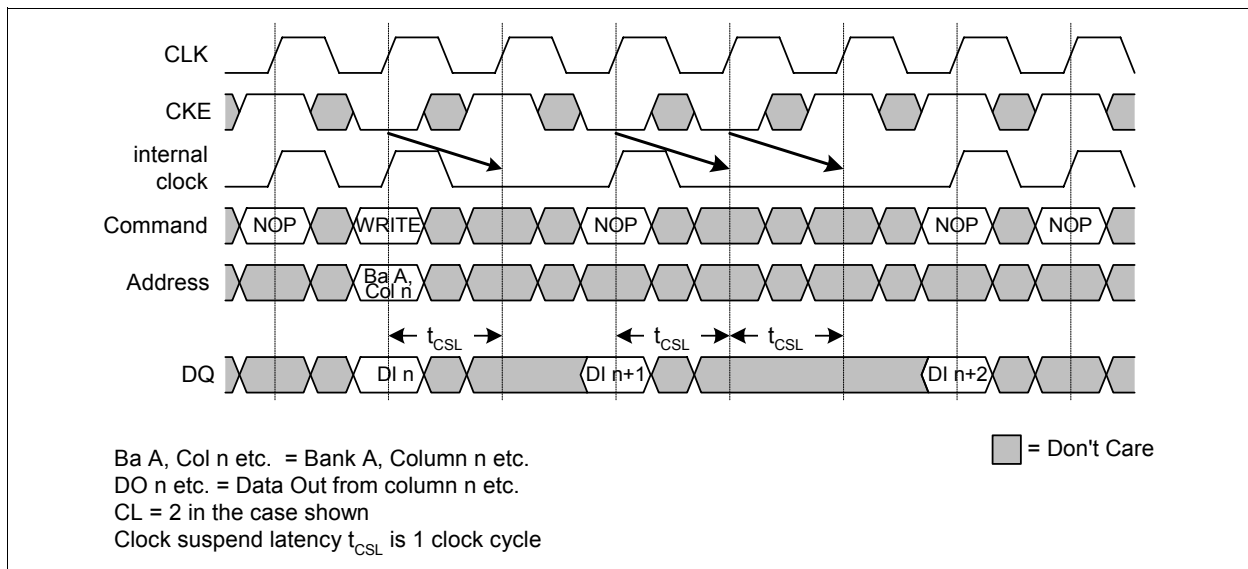

Figure 31 Clock Suspend Mode for WRITE Bursts

2.4.6.3 WRITE - DQM Operation

DQM may be used to mask write data: when asserted HIGH, input data will be masked and no write will be performed. The generic timing parameters as listed in [Table 11](#) also apply to this DQM operation. The write burst in progress is not affected and will continue as programmed.

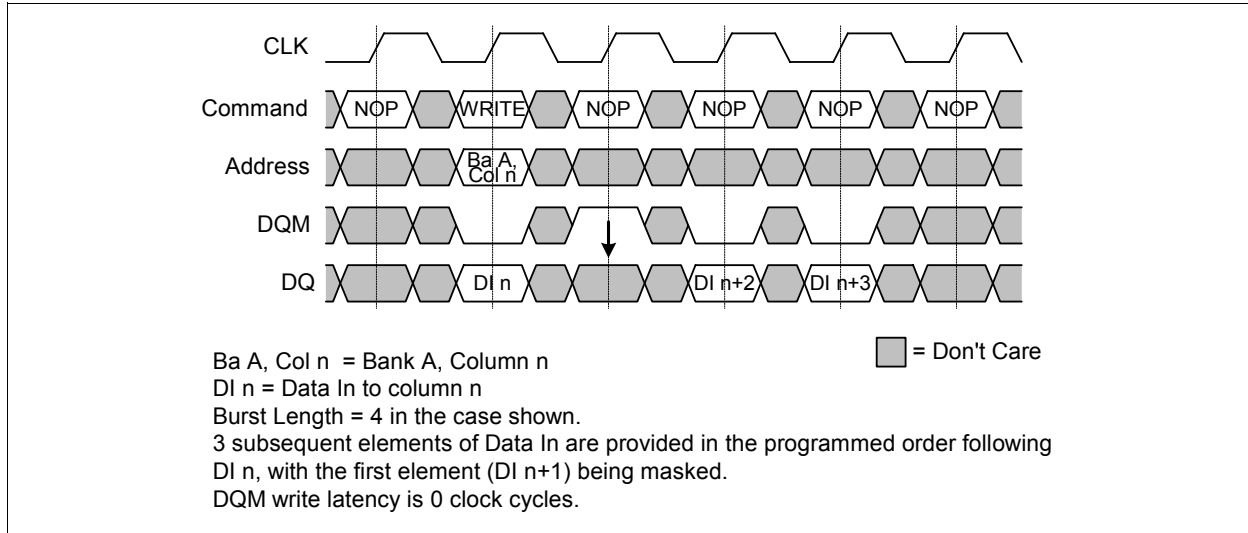

Figure 32 WRITE Burst - DQM Operation

2.4.6.4 WRITE to READ

A WRITE burst may be followed by, or truncated with a READ command. The READ command can be performed to the same or a different (active) bank. With the registration of the READ command, data inputs will be ignored and no WRITE will be performed, as shown in [Figure 33](#).

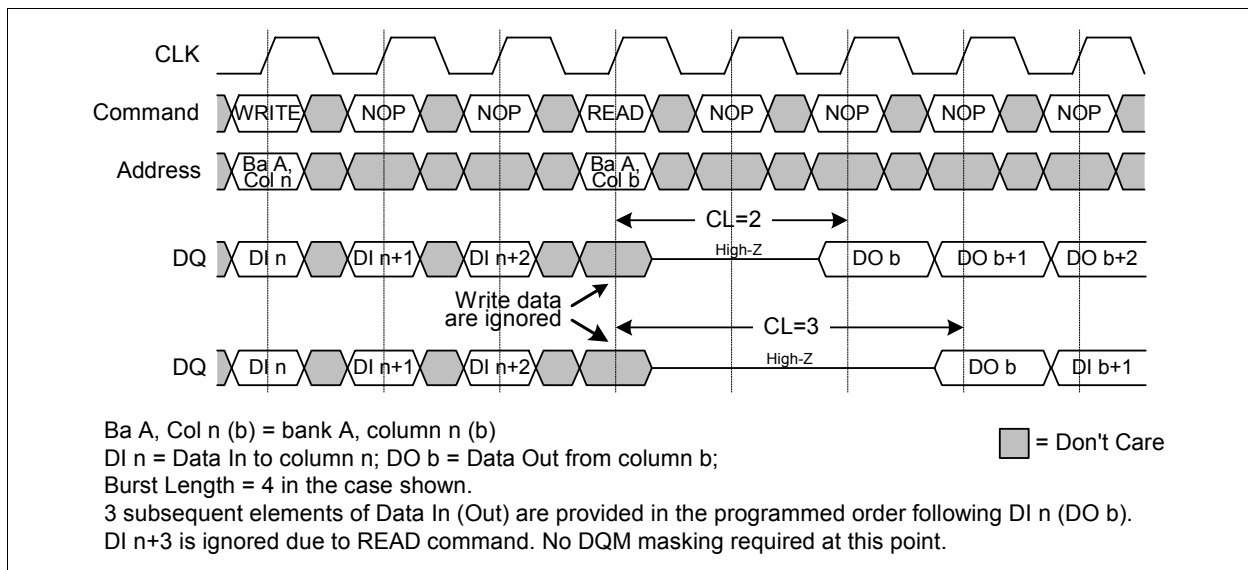

Figure 33 WRITE to READ Timing

2.4.6.5 WRITE to PRECHARGE

A WRITE burst may be followed by, or truncated with a PRECHARGE command to the same bank, provided that Auto Precharge was not activated. This is shown in **Figure 34**.

The PRECHARGE command should be issued t_{WR} after the clock edge at which the last desired data element of the WRITE burst was registered. Additionally, when truncating a WRITE burst, DQM must be pulled to mask input data presented during t_{WR} prior to the PRECHARGE command. Following the PRECHARGE command, a subsequent ACTIVE command to the same bank cannot be issued until t_{RP} is met.

In the case of a WRITE being executed to completion, a PRECHARGE command issued at the optimum time (as described above) provides the same operation that would result from the same WRITE burst with Auto Precharge enabled. The disadvantage of the PRECHARGE command is that it requires that the command and address busses be available at the appropriate time to issue the command. The advantage of the PRECHARGE command is that it can be used to truncate bursts.

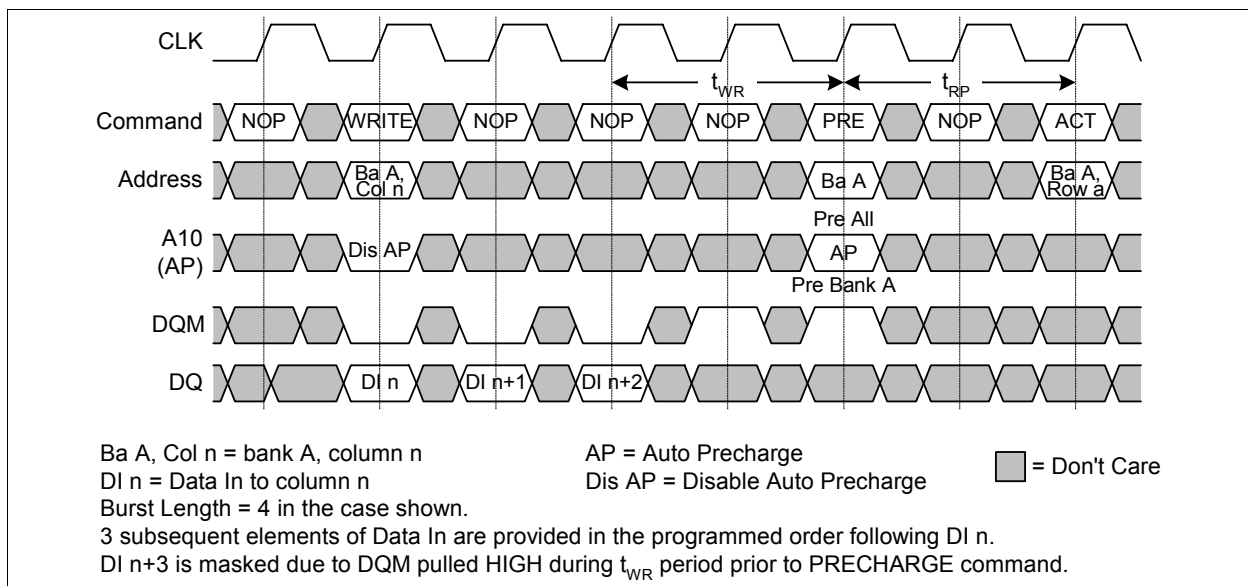

Figure 34 WRITE to PRECHARGE Timing

2.4.7 BURST TERMINATE

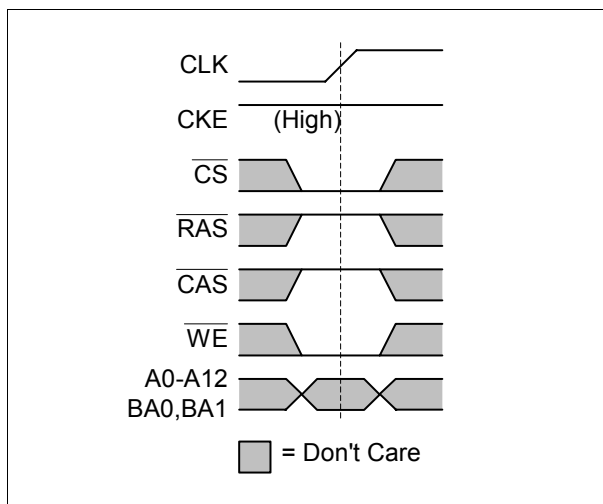

Figure 35 BURST TERMINATE Command

The BURST TERMINATE command is used to truncate READ or WRITE bursts (with Auto Precharge disabled). The most recently registered READ or WRITE command prior to the BURST TERMINATE command will be truncated, as shown in **Figure 18** and **Figure 30**, respectively.

The BURST TERMINATE command is not allowed for truncation of READ or WRITE bursts with Auto Precharge enabled.

2.4.8 PRECHARGE

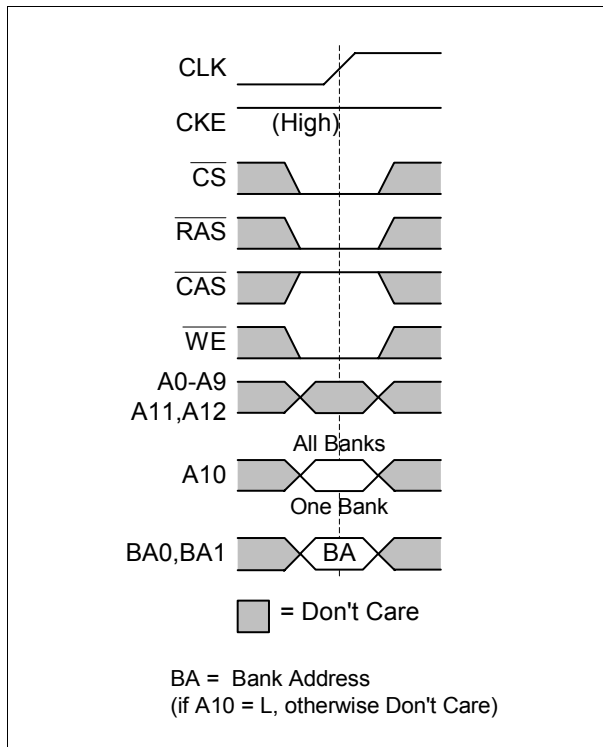

Figure 36 PRECHARGE Command

The PRECHARGE command is used to deactivate (close) the open row in a particular bank or the open row in all banks. The bank(s) will be available for a subsequent row access a specified time (t_{RP}) after the PRECHARGE command is issued. Input A10 determines whether one or all banks are to be precharged, and in the case where only one bank is to be precharged, inputs BA0, BA1 select the bank. Otherwise BA0, BA1 are treated as “Don’t Care”.

Once a bank has been precharged, it is in the idle state and must be activated prior to any READ or WRITE commands being issued to that bank. A PRECHARGE command will be treated as a NOP if there is no open row in that bank, or if the previously open row is already in the process of precharging.

2.4.8.1 AUTO PRECHARGE

Auto Precharge is a feature which performs the same individual-bank precharge functions described above, but without requiring an explicit command. This is accomplished by using A10 to enable Auto Precharge in conjunction with a specific READ or WRITE command. A precharge of the bank/row that is addressed with the READ or WRITE command is automatically performed upon completion of the READ or WRITE burst. Auto Precharge is nonpersistent in that it is either enabled or disabled for each individual READ or WRITE command. Auto Precharge ensures that the precharge is initiated at the earliest valid stage within a burst. The user must not issue another command to the same bank until the precharge (t_{RP}) is completed. This is determined as if an explicit PRECHARGE command was issued at the earliest possible time, as described for each burst type.

Table 12 Timing Parameters for PRECHARGE

Parameter	Symbol	- 7.5		Units	Notes
		min.	max.		
ACTIVE to PRECHARGE command period	t_{RAS}	45	100k	ns	1)
WRITE recovery time	t_{WR}	14	–	ns	1)
PRECHARGE command period	t_{RP}	19	–	ns	1)

1) These parameters account for the number of clock cycles and depend on the operating frequency as follows:
no. of clock cycles = specified delay / clock period; round up to next integer.

2.4.8.2 CONCURRENT AUTO PRECHARGE

A READ or WRITE burst with Auto Precharge enabled can be interrupted by a subsequent READ or WRITE command issued to a different bank.

Figure 37 shows a READ with Auto Precharge to bank n, interrupted by a READ (with or without Auto Precharge) to bank m. The READ to bank m will interrupt the READ to bank n, CAS latency later. The precharge to bank n will begin when the READ to bank m is registered.

Figure 38 shows a READ with Auto Precharge to bank n, interrupted by a WRITE (with or without Auto Precharge) to bank m. The precharge to bank n will begin when the WRITE to bank m is registered. DQM should be pulled HIGH two clock cycles prior to the WRITE to prevent bus contention.

Figure 39 shows a WRITE with Auto Precharge to bank n, interrupted by a READ (with or without Auto Precharge) to bank m. The precharge to bank n will begin t_{WR} after the new command to bank m is registered. The last valid data-in to bank n is one clock cycle prior to the READ to bank m.

Figure 40 shows a WRITE with Auto Precharge to bank n, interrupted by a WRITE (with or without Auto Precharge) to bank m. The precharge to bank n will begin t_{WR} after the WRITE to bank m is registered. The last valid data-in to bank n is one clock cycle prior to the WRITE to bank m.

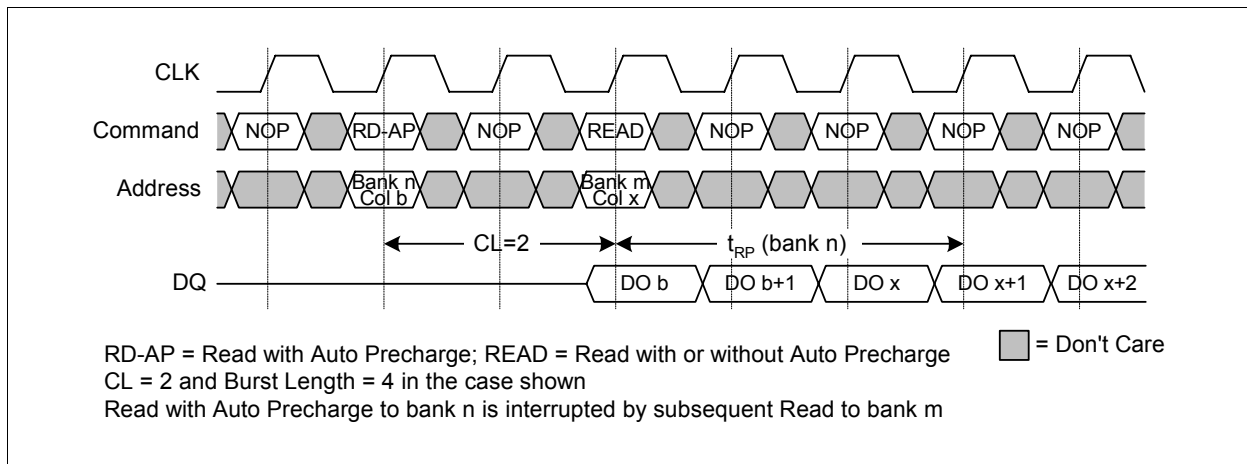

Figure 37 READ with Auto Precharge Interrupted by READ

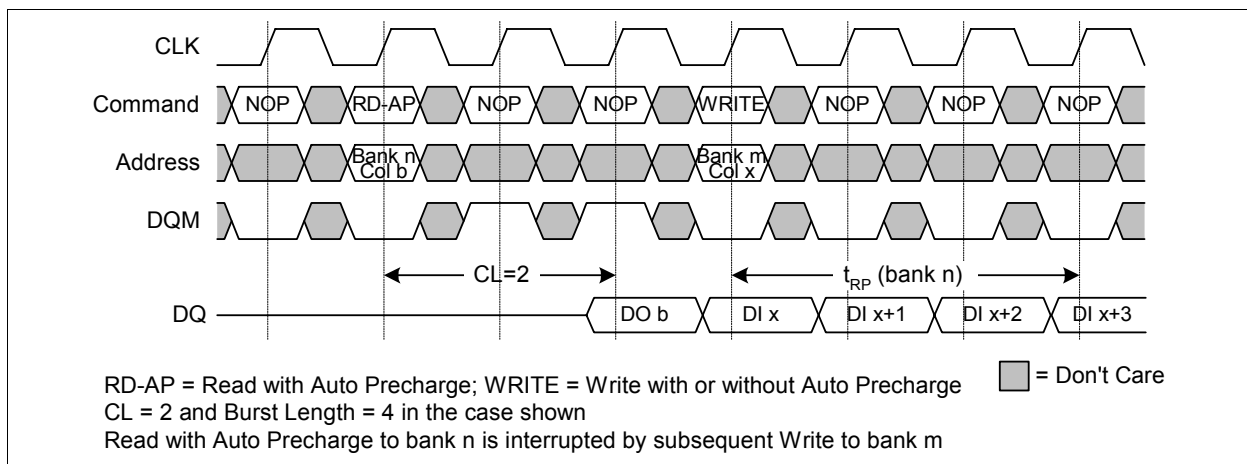

Figure 38 READ with Auto Precharge Interrupted by WRITE

Functional Description

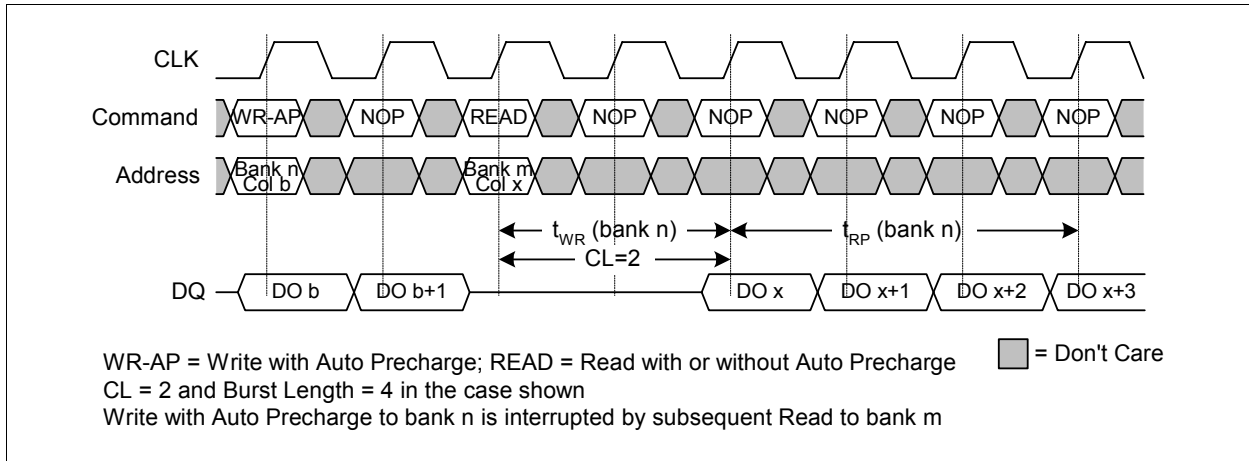

Figure 39 WRITE with Auto Precharge Interrupted by READ

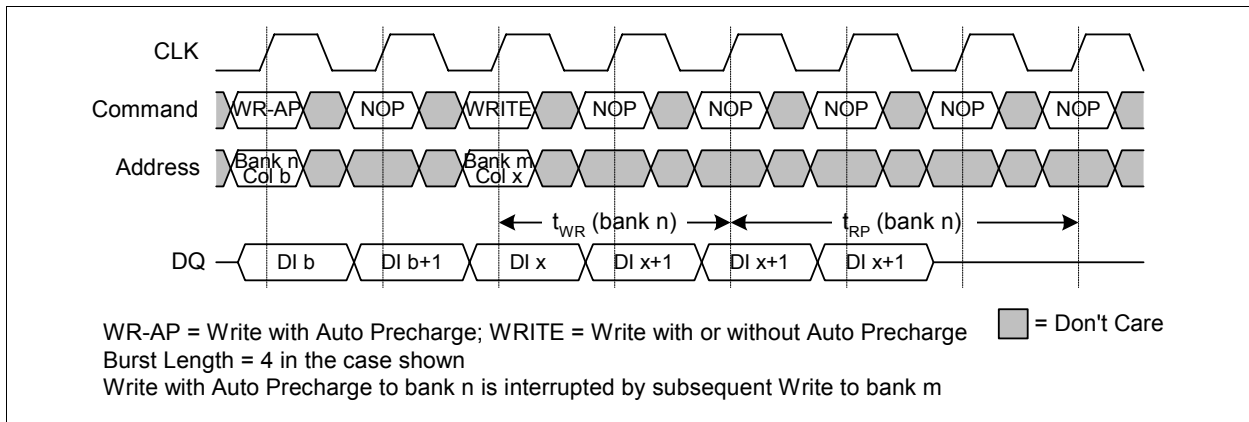

Figure 40 WRITE with Auto Precharge Interrupted by WRITE

2.4.9 AUTO REFRESH and SELF REFRESH

The Mobile-RAM requires a refresh of all rows in a rolling interval. Each refresh is generated in one of two ways: by an explicit AUTO REFRESH command, or by an internally timed event in SELF REFRESH mode.

2.4.9.1 AUTO REFRESH

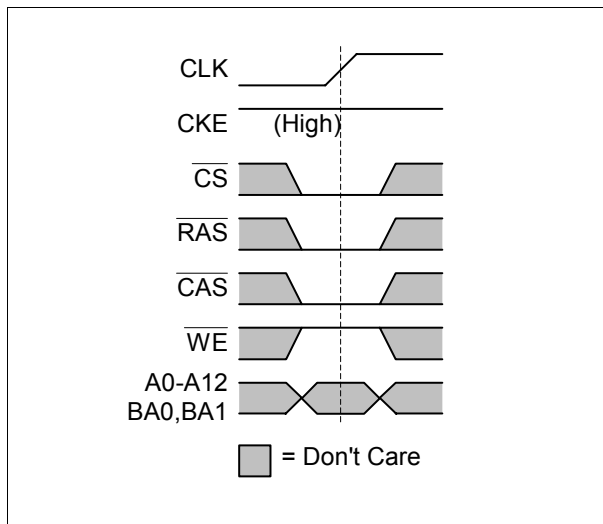

Figure 41 AUTO REFRESH Command

Auto Refresh is used during normal operation of the Mobile-RAM. The command is nonpersistent, so it must be issued each time a refresh is required. A minimum row cycle time (t_{RC}) is required between two AUTO REFRESH commands. The same rule applies to any access command after the auto refresh operation. All banks must be precharged prior to the AUTO REFRESH command.

The refresh addressing is generated by the internal refresh controller. This makes the address bits "Don't Care" during an AUTO REFRESH command. The Mobile-RAM requires AUTO REFRESH cycles at an average periodic interval of 7.8 μs (max.). Partial array mode has no influence on auto refresh mode.

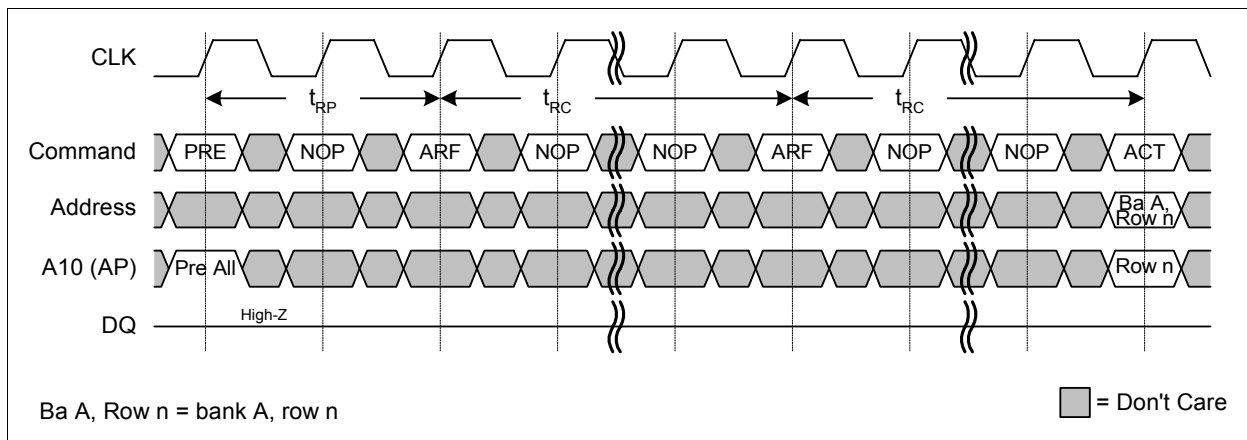

Figure 42 Auto Refresh

2.4.9.2 SELF REFRESH

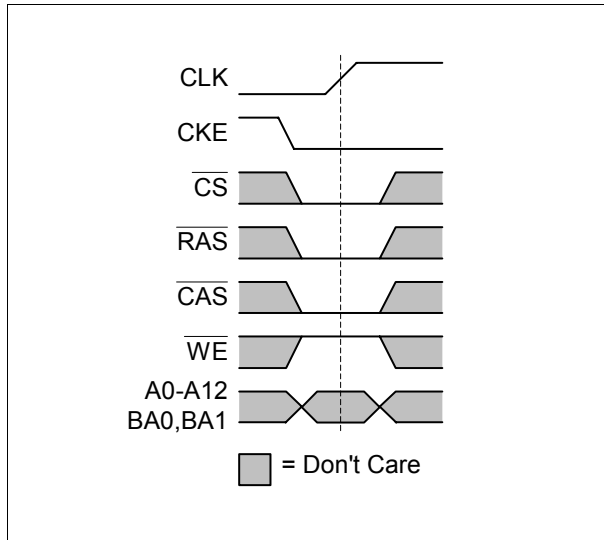

Figure 43 SELF REFRESH Entry Command

The SELF REFRESH command can be used to retain data in the Mobile-RAM, even if the rest of the system is powered down. When in the self refresh mode, the Mobile-RAM retains data without external clocking. The SELF REFRESH command is initiated like an AUTO REFRESH command except CKE is LOW. Input signals except CKE are “Don’t Care” during SELF REFRESH.

The procedure for exiting SELF REFRESH requires a stable clock prior to CKE returning HIGH. Once CKE is HIGH, NOP commands must be issued for t_{RC} because time is required for a completion of any internal refresh in progress.

The use of SELF REFRESH mode introduces the possibility that an internally timed event can be missed when CKE is raised for exit from SELF REFRESH mode. Upon exit from SELF REFRESH an extra AUTO REFRESH command is recommended.

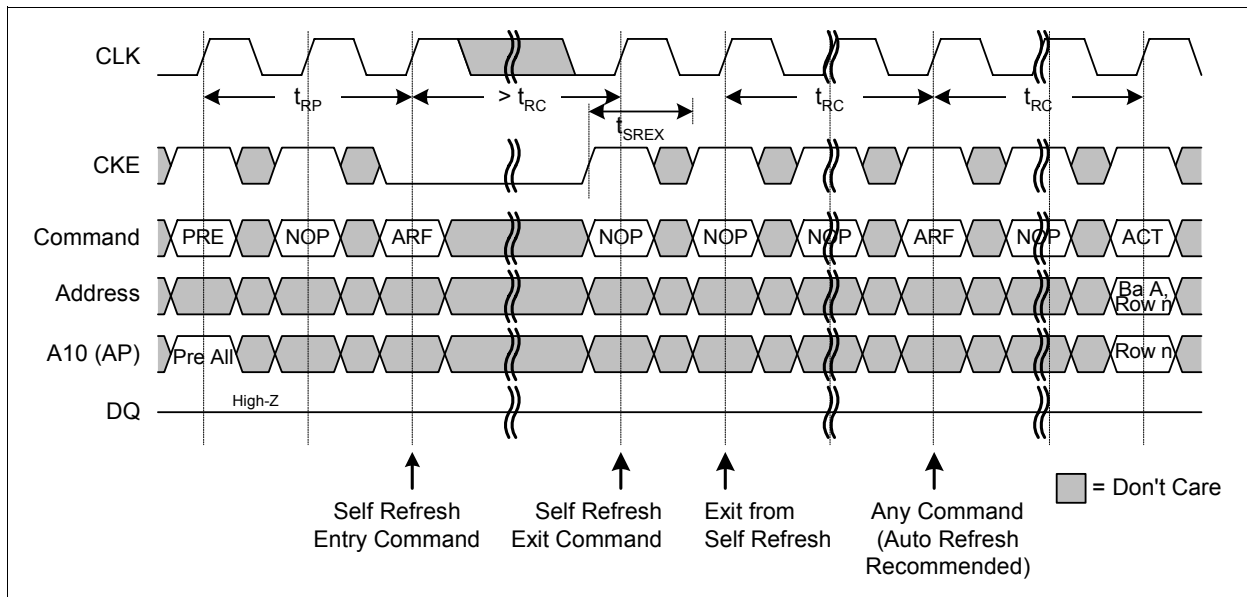

Figure 44 Self Refresh Entry and Exit

Table 13 Timing Parameters for AUTO REFRESH and SELF REFRESH

Parameter	Symbol	- 7.5		Units	Notes
		min.	max.		
ACTIVE to ACTIVE command period	t_{RC}	67	–	ns	1)
PRECHARGE command period	t_{RP}	19	–	ns	1)
Refresh period (8192 rows)	t_{REF}	–	64	ms	1)
Self refresh exit time	t_{SREX}	1	–	t_{CK}	1)

1) These parameters account for the number of clock cycles and depend on the operating frequency as follows:
 no. of clock cycles = specified delay / clock period; round up to next integer.

2.4.10 POWER DOWN

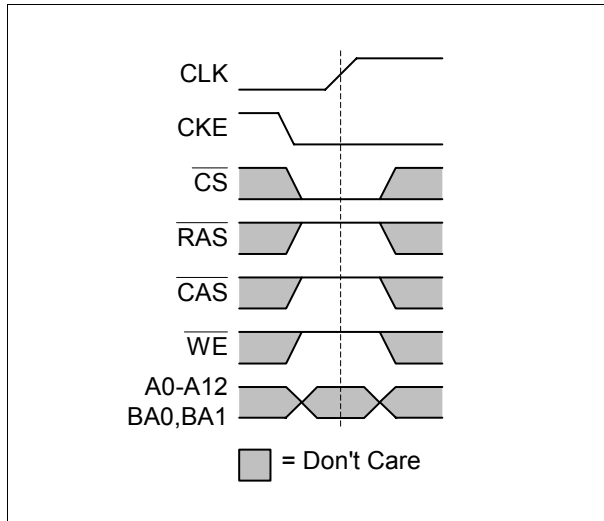

Figure 45 Power Down Entry Command

Power-down is entered when CKE is registered LOW (no accesses can be in progress). If power-down occurs when all banks are idle, this mode is referred to as precharge power-down; if power-down occurs when there is a row active in any bank, this mode is referred to as active power-down. Entering power-down deactivates the input and output buffers, excluding CLK and CKE. CKE LOW must be maintained during power-down.

Power-down duration is limited by the refresh requirements of the device (t_{REF}).

The power-down state is synchronously exited when CKE is registered HIGH (along with a NOP or DESELECT command). One clock delay is required for power down entry and exit.

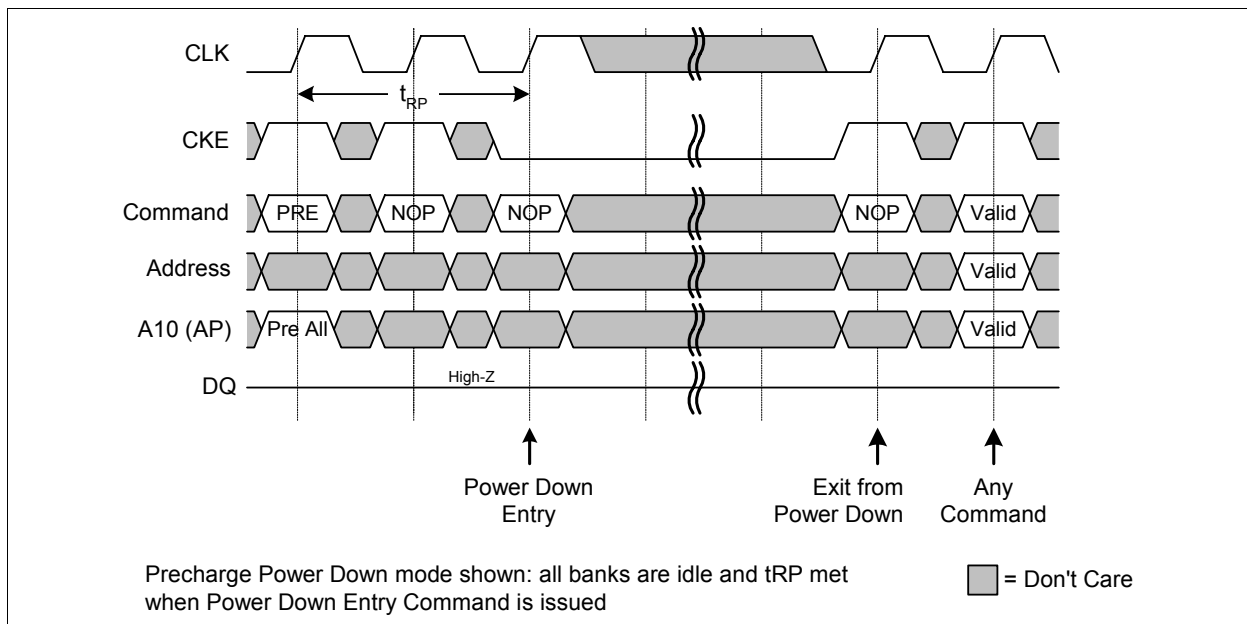

Figure 46 Power Down Entry and Exit

2.4.10.1 DEEP POWER DOWN

The deep power down mode is a unique function on Low Power SDRAM devices with extremely low current consumption. Deep power down mode is entered using the BURST TERMINATE command (cf. Figure 35) except that CKE is LOW. All internal voltage generators inside the device are stopped and all memory data is lost in this mode. To enter the deep power down mode all banks must be precharged.

The deep power down mode is asynchronously exited by asserting CKE HIGH. After the exit, the same command sequence as for power-up initialization, including the 200µs initial pause, has to be applied before any other command may be issued (cf. Figure 3 and Figure 4).

2.5 Function Truth Tables

Table 14 Current State Bank n - Command to Bank n

Current State	\overline{CS}	\overline{RAS}	\overline{CAS}	\overline{WE}	Command / Action	Notes
Any	H	X	X	X	DESELECT (NOP / continue previous operation)	1)2)3)4)5)6)
	L	H	H	H	NO OPERATION (NOP / continue previous operation)	1) to 6)
Idle	L	L	H	H	ACTIVE (select and activate row)	1) to 6)
	L	L	L	H	AUTO REFRESH	1) to 7)
	L	L	L	L	MODE REGISTER SET	1) to 7)
	L	L	H	L	PRECHARGE	1) to 6), 8)
Row Active	L	H	L	H	READ (select column and start READ burst)	1) to 6), 9)
	L	H	L	L	WRITE (select column and start WRITE burst)	1) to 6), 9)
	L	L	H	L	PRECHARGE (deactivate row in bank or banks)	1) to 6), 10)
Read (Auto-Precharge Disabled)	L	H	L	H	READ (select column and start new READ burst)	1) to 6), 9)
	L	H	L	L	WRITE (select column and start new WRITE burst)	1) to 6), 9)
	L	L	H	L	PRECHARGE (truncate READ burst, start precharge)	1) to 6), 10)
	L	H	H	L	BURST TERMINATE	1) to 6), 11)
Write (Auto-Precharge Disabled)	L	H	L	H	READ (select column and start READ burst)	1) to 6), 9)
	L	H	L	L	WRITE (select column and start WRITE burst)	1) to 6), 9)
	L	L	H	L	PRECHARGE (truncate WRITE burst, start precharge)	1) to 6), 10)
	L	H	H	L	BURST TERMINATE	1) to 6), 11)

- 1) This table applies when $CKEn-1$ was HIGH and $CKEn$ is HIGH and after t_{RC} has been met (if the previous state was self refresh).
- 2) This table is bank-specific, except where noted, i.e., the current state is for a specific bank and the commands shown are those allowed to be issued to that bank when in that state. Exceptions are covered in the notes below.
- 3) Current state definitions:
 - Idle: The bank has been precharged, and t_{RP} has been met.
 - Row Active: A row in the bank has been activated, and t_{RCD} has been met. No data bursts/accesses and no register accesses are in progress.
 - Read: A READ burst has been initiated, with Auto Precharge disabled, and has not yet terminated or been terminated.
 - Write: A WRITE burst has been initiated, with Auto Precharge disabled, and has not yet terminated or been terminated.
- 4) The following states must not be interrupted by a command issued to the same bank. DESELECT or NOP commands, or allowable commands to the other bank should be issued on any clock edge occurring during these states. Allowable commands to the other bank are determined by its current state and according to [Table 15](#).
 - Precharging: Starts with registration of a PRECHARGE command and ends when t_{RP} is met. Once t_{RP} is met, the bank is in the "idle" state.
 - Row Activating: Starts with registration of an ACTIVE command and ends when t_{RCD} is met. Once t_{RCD} is met, the bank is in the "row active" state.
 - Read with AP Enabled: Starts with registration of a READ command with Auto Precharge enabled and ends when t_{RP} has been met. Once t_{RP} is met, the bank is in the idle state.
 - Write with AP Enabled: Starts with registration of a WRITE command with Auto Precharge enabled and ends when t_{RP} has been met. Once t_{RP} is met, the bank is in the idle state.

Functional Description

- 5) The following states must not be interrupted by any executable command; DESELECT or NOP commands must be applied on each positive clock edge during these states.
- Refreshing: Starts with registration of an AUTO REFRESH command and ends when t_{RC} is met. Once t_{RC} is met, the SDRAM is in the “all banks idle” state.
- Accessing Mode Register: Starts with registration of a MODE REGISTER SET command and ends when t_{MRD} has been met. Once t_{MRD} is met, the SDRAM is in the “all banks idle” state.
- Precharging All: Starts with registration of a PRECHARGE ALL command and ends when t_{RP} is met. Once t_{RP} is met, all banks are in the idle state.
- 6) All states and sequences not shown are illegal or reserved.
- 7) Not bank-specific; requires that all banks are idle and no bursts are in progress.
- 8) Same as NOP command in that state.
- 9) READs or WRITEs listed in the Command/Action column include READs or WRITEs with Auto Precharge enabled and READs or WRITEs with Auto Precharge disabled.
- 10) May or may not be bank-specific; if multiple banks are to be precharged, each must be in a valid state for precharging.
- 11) Not bank-specific; BURST TERMINATE affects the most recent READ or WRITE burst, regardless of bank.

Table 15 Current State Bank n - Command to Bank m (different bank)

Current State	CS	RAS	CAS	WE	Command / Action	Notes
Any	H	X	X	X	DESELECT (NOP / continue previous operation)	1)2)3)4)5)6)
	L	H	H	H	NO OPERATION (NOP / continue previous operation)	1) to 6)
Idle	X	X	X	X	Any command otherwise allowed to bank n	1) to 6)
Row Activating, Active, or Precharging	L	L	H	H	ACTIVE (select and activate row)	1) to 6)
	L	H	L	H	READ (select column and start READ burst)	1) to 7)
	L	H	L	L	WRITE (select column and start WRITE burst)	1) to 7)
	L	L	H	L	PRECHARGE (deactivate row in bank or banks)	1) to 6)
Read (Auto-Precharge Disabled)	L	L	H	H	ACTIVE (select and activate row)	1) to 6)
	L	H	L	H	READ (select column and start READ burst)	1) to 7)
	L	H	L	L	WRITE (select column and start WRITE burst)	1) to 8)
	L	L	H	L	PRECHARGE (deactivate row in bank or banks)	1) to 6)
Write (Auto-Precharge Disabled)	L	L	H	H	ACTIVE (select and activate row)	1) to 6)
	L	H	L	H	READ (select column and start READ burst)	1) to 7)
	L	H	L	L	WRITE (select column and start WRITE burst)	1) to 7)
	L	L	H	L	PRECHARGE (deactivate row in bank or banks)	1) to 6)
Read (with Auto-Precharge)	L	L	H	H	ACTIVE (select and activate row)	1) to 6)
	L	H	L	H	READ (select column and start READ burst)	1) to 7), 9)
	L	H	L	L	WRITE (select column and start WRITE burst)	1) to 9)
	L	L	H	L	PRECHARGE (deactivate row in bank or banks)	1) to 6)
Write (with Auto-Precharge)	L	L	H	H	ACTIVE (select and activate row)	1) to 6)
	L	H	L	H	READ (select column and start READ burst)	1) to 7), 9)
	L	H	L	L	WRITE (select column and start WRITE burst)	1) to 7), 9)
	L	L	H	L	PRECHARGE (deactivate row in bank or banks)	1) to 6)

- 1) This table applies when CKEn-1 was HIGH and CKEn is HIGH and after t_{RC} has been met (if the previous state was Self Refresh).
- 2) This table describes alternate bank operation, except where noted, i.e., the current state is for bank n and the commands shown are those allowed to be issued to bank m (assuming that bank m is in such a state that the given command is allowable). Exceptions are covered in the notes below.

Functional Description

- 3) Current state definitions:
- Idle: The bank has been precharged, and t_{RP} has been met.
 - Row Active: A row in the bank has been activated, and t_{RCD} has been met. No data bursts/accesses and no register accesses are in progress.
 - Read: A READ burst has been initiated, with Auto Precharge disabled, and has not yet terminated or been terminated.
 - Write: A WRITE burst has been initiated, with Auto Precharge disabled, and has not yet terminated or been terminated.
 - Read with AP Enabled: Starts with registration of a READ command with Auto Precharge enabled and ends when t_{RP} has been met. Once t_{RP} is met, the bank is in the idle state.
 - Write with AP Enabled: Starts with registration of a WRITE command with Auto Precharge enabled and ends when t_{RP} has been met. Once t_{RP} is met, the bank is in the idle state.
- 4) AUTO REFRESH, SELF REFRESH and MODE REGISTER SET commands may only be issued when all banks are idle.
- 5) A BURST TERMINATE command cannot be issued to another bank; it applies to the bank represented by the current state only.
- 6) All states and sequences not shown are illegal or reserved.
- 7) READs or WRITEs listed in the Command/Action column include READs or WRITEs with Auto Precharge enabled and READs or WRITEs with Auto Precharge disabled.
- 8) Requires appropriate DQM masking.
- 9) Concurrent Auto Precharge: bank n will start precharging when its burst has been interrupted by a READ or WRITE command to bank m.

Table 16 Truth Table - CKE

CKEn-1	CKEn	Current State	Command	Action	Notes
L	L	Power Down	X	Maintain Power Down	1)2)3)4)
		Self Refresh	X	Maintain Self Refresh	1) to 4)
		Clock Suspend	X	Maintain Clock Suspend	1) to 4)
		Deep Power Down	X	Maintain Deep Power Down	1) to 4)
L	H	Power Down	DESELECT or NOP	Exit Power Down	1) to 4)
		Self Refresh	DESELECT or NOP	Exit Self Refresh	1) to 5)
		Clock Suspend	X	Exit Clock Suspend	1) to 4)
		Deep Power Down	X	Exit Deep Power Down	1) to 4), 6)
H	L	All Banks Idle	DESELECT or NOP	Enter Precharge Power Down	1) to 4)
		Bank(s) Active	DESELECT or NOP	Enter Active Power Down	1) to 4)
		All Banks Idle	AUTO REFRESH	Enter Self Refresh	1) to 4)
		Read / Write burst	(valid)	Enter Clock Suspend	1) to 4)
H	H	see Table 14 and Table 15			1) to 4)

- 1) CKEn is the logic state of CKE at clock edge n; CKEn-1 was the state of CKE at the previous clock edge.
- 2) Current state is the state immediately prior to clock edge n.
- 3) COMMAND n is the command registered at clock edge n; ACTION n is a result of COMMAND n.
- 4) All states and sequences not shown are illegal or reserved.
- 5) DESELECT or NOP commands should be issued on any clock edges occurring during t_{RC} period.
- 6) Exit from DEEP POWER DOWN requires the same command sequence as for power-up initialization.

3 Electrical Characteristics

3.1 Operating Conditions

Table 17 Absolute Maximum Ratings

Parameter	Symbol	Values		Unit	
		min.	max.		
Power Supply Voltage	V_{DD}	-0.3	2.7	V	
Power Supply Voltage for Output Buffer	V_{DDQ}	-0.3	2.7	V	
Input Voltage	V_{IN}	-0.3	$V_{DDQ} + 0.3$	V	
Output Voltage	V_{OUT}	-0.3	$V_{DDQ} + 0.3$	V	
Operation Case Temperature	Commercial	T_C	0	+70	°C
	Extended	T_C	-25	+85	°C
Storage Temperature	T_{STG}	-55	+150	°C	
Power Dissipation	P_D	–	0.7	W	
Short Circuit Output Current	I_{OUT}	–	50	mA	

Attention: Stresses above those listed here may cause permanent damage to the device. Exposure to absolute maximum rating conditions for extended periods may affect device reliability. Maximum ratings are absolute ratings; exceeding only one of these values may cause irreversible damage to the integrated circuit.

Table 18 Pin Capacitances¹⁾²⁾

Parameter	Symbol	Values		Unit
		min.	max.	
Input capacitance: CLK	C_{I1}	1.5	3.0	pF
Input capacitance: all other input pins	C_{I2}	1.5	3.0	pF
Input/Output capacitance: DQ	C_{IO}	3.0	5.0	pF

1) These values are not subject to production test but verified by device characterization.

2) Input capacitance is measured according to JEP147 with VDD, VDDQ applied and all other pins (except the pin under test) floating. DQ's should be in high impedance state. This may be achieved by pulling CKE to low level.

Electrical Characteristics

Table 19 Electrical Characteristics¹⁾

Parameter	Symbol	Values		Unit	Notes
		min.	max.		
Power Supply Voltage	V_{DD}	1.65	1.95	V	–
Power Supply Voltage for DQ Output Buffer	V_{DDQ}	1.65	1.95	V	–
Input high voltage	V_{IH}	$0.8 \times V_{DDQ}$	$V_{DDQ} + 0.3$	V	2)
Input low voltage	V_{IL}	-0.3	0.3	V	2)
Output high voltage	V_{OH}	$V_{DDQ} - 0.2$	–	V	–
Output low voltage	V_{OL}	–	0.2	V	–
Input leakage current	I_{IL}	-1.0	1.0	μA	–
Output leakage current	I_{OL}	-1.5	1.5	μA	–

1) $0\text{ }^{\circ}\text{C} \leq T_C \leq 70\text{ }^{\circ}\text{C}$ (comm.); $-25\text{ }^{\circ}\text{C} \leq T_C \leq 85\text{ }^{\circ}\text{C}$ (ext.); all voltages referenced to V_{SS} . V_{SS} and V_{SSQ} must be at same potential.

2) V_{IH} may overshoot to $V_{DD} + 0.8\text{ V}$ for pulse width $< 4\text{ ns}$; V_{IL} may undershoot to -0.8 V for pulse width $< 4\text{ ns}$.
Pulse width measured at 50% with amplitude measured between peak voltage and DC reference level.

3.2 AC Characteristics

Table 20 AC Characteristics¹⁾²⁾³⁾⁴⁾

Parameter	Symbol	- 7.5		Unit	Notes	
		min.	max.			
Clock cycle time	CL = 3	t_{CK}	7.5	–	ns	–
	CL = 2		9.5	–	ns	
Clock frequency	CL = 3	f_{CK}	–	133	MHz	–
	CL = 2		–	105	MHz	
Access time from CLK	CL = 3	t_{AC}	–	5.4	ns	5)6)
	CL = 2		–	6.0	ns	
Clock high-level width		t_{CH}	2.5	–	ns	–
Clock low-level width		t_{CL}	2.5	–	ns	–
Address, data and command input setup time		t_{IS}	1.5	–	ns	7)
Address, data and command input hold time		t_{IH}	0.8	–	ns	7)
MODE REGISTER SET command period		t_{MRD}	2	–	t_{CK}	–
DQ low-impedance time from CLK		t_{LZ}	1.0	–	ns	–
DQ high-impedance time from CLK		t_{HZ}	3.0	7.0	ns	–
Data out hold time		t_{OH}	2.5	–	ns	5)6)
DQM to DQ High-Z delay (READ Commands)		t_{DQZ}	–	2	t_{CK}	–
DQM write mask latency		t_{DQW}	0	–	t_{CK}	–
ACTIVE to ACTIVE command period		t_{RC}	67	–	ns	8)
ACTIVE to READ or WRITE delay		t_{RCD}	19	–	ns	8)
ACTIVE bank A to ACTIVE bank B delay		t_{RRD}	15	–	ns	8)
ACTIVE to PRECHARGE command period		t_{RAS}	45	100k	ns	8)
WRITE recovery time		t_{WR}	14	–	ns	9)
PRECHARGE command period		t_{RP}	19	–	ns	8)
Refresh period (8192 rows)		t_{REF}	–	64	ms	–
Self refresh exit time		t_{SREX}	1	–	t_{CK}	–

1) $0\text{ }^{\circ}\text{C} \leq T_C \leq 70\text{ }^{\circ}\text{C}$ (comm.); $-25\text{ }^{\circ}\text{C} \leq T_C \leq 85\text{ }^{\circ}\text{C}$ (ext.); $V_{DD} = V_{DDQ} = 1.8\text{ V} \pm 0.15\text{ V}$;

2) All parameters assumes proper device initialization.

3) AC timing tests measured at 0.9 V.

4) The transition time t_T is measured between V_{IH} and V_{IL} ; all AC characteristics assume $t_T = 1\text{ ns}$.

5) Specified t_{AC} and t_{OH} parameters are measured with a 30 pF capacitive load only as shown below:

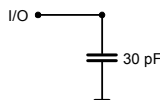

6) If $t_T(\text{CLK}) > 1\text{ ns}$, a value of $(t_T/2 - 0.5)\text{ ns}$ has to be added to this parameter.

7) If $t_T > 1\text{ ns}$, a value of $(t_T - 1)\text{ ns}$ has to be added to this parameter.

8) These parameter account for the number of clock cycles and depend on the operating frequency, as follows:
no. of clock cycles = specified delay / clock period; round up to next integer.

9) The write recovery time of $t_{WR} = 14\text{ ns}$ allows the use of one clock cycle for the write recovery time when $f_{CK} \leq 72\text{ MHz}$. With $f_{CK} > 72\text{ MHz}$ two clock cycles for t_{WR} are mandatory. Infineon Technologies recommends to use two clock cycles for the write recovery time in all applications.

3.3 Operating Currents

Table 21 Maximum Operating Currents¹⁾

Parameter & Test Conditions	Symbol	Values	Unit	Notes
		- 7.5		
Operating current: one bank: active / read / precharge, BL = 1, $t_{RC} = t_{RCmin}$	I_{DD1}	60	mA	2)3)
Precharge power-down standby current: all banks idle, $\overline{CS} \geq V_{IHmin}$, $CKE \leq V_{ILmax}$, inputs changing once every two clock cycles	I_{DD2P}	0.5	mA	2)
Precharge power-down standby current with clock stop: all banks idle, $\overline{CS} \geq V_{IHmin}$, $CKE \leq V_{ILmax}$, all inputs stable	I_{DD2PS}	0.35	mA	–
Precharge non power-down standby current: all banks idle, $\overline{CS} \geq V_{IHmin}$, $CKE \geq V_{IHmin}$, inputs changing once every two clock cycles	I_{DD2N}	13	mA	2)
Precharge non power-down standby current with clock stop: all banks idle, $\overline{CS} \geq V_{IHmin}$, $CKE \geq V_{IHmin}$, all inputs stable	I_{DD2NS}	1.0	mA	–
Active power-down standby current: one bank active, $\overline{CS} \geq V_{IHmin}$, $CKE \leq V_{ILmax}$, inputs changing once every two clock cycles	I_{DD3P}	1.0	mA	2)
Active power-down standby current with clock stop: one bank active, $\overline{CS} \geq V_{IHmin}$, $CKE \leq V_{ILmax}$, all inputs stable	I_{DD3PS}	0.5	mA	–
Active non power-down standby current: one bank active, $\overline{CS} \geq V_{IHmin}$, $CKE \geq V_{IHmin}$, inputs changing once every two clock cycles	I_{DD3N}	15	mA	2)
Active non power-down standby current with clock stop: one bank active, $\overline{CS} \geq V_{IHmin}$, $CKE \geq V_{IHmin}$, all inputs stable	I_{DD3NS}	1.5	mA	–
Operating burst read current: all banks active; continuous burst read, inputs changing once every two clock cycles	I_{DD4}	45	mA	2)3)
Auto-Refresh current: $t_{RC} = t_{RCmin}$, “burst refresh”, inputs changing once every two clock cycles	I_{DD5}	90	mA	2)
Self Refresh current: self refresh mode, $\overline{CS} \geq V_{IHmin}$, $CKE \leq V_{ILmax}$, all inputs stable	I_{DD6}	see Table 22		–
Deep Power Down current	I_{DD7}	20	μA	–

1) $0\text{ }^{\circ}\text{C} \leq T_C \leq 70\text{ }^{\circ}\text{C}$ (comm.); $-25\text{ }^{\circ}\text{C} \leq T_C \leq 85\text{ }^{\circ}\text{C}$ (ext.); $V_{DD} = V_{DDQ} = 1.8\text{ V} \pm 0.15\text{ V}$;
Recommended Operating Conditions unless otherwise noted

2) These values are measured with $t_{CK} = 7.5\text{ ns}$

3) All parameters are measured with no output loads.

Table 22 Self Refresh Currents¹⁾²⁾

Parameter & Test Conditions	Max. Temperature	Symbol	Values		Units	Notes
			typ.	max.		
Self Refresh Current: Self refresh mode, full array activation (PASR = 000)	85 °C	I_{DD6}	530	600	μA	-
	70 °C		350	-		
	45 °C		235	-		
	25 °C		215	-		
Self Refresh Current: Self refresh mode, half array activation (PASR = 001)	85 °C		365	415		
	70 °C		260	-		
	45 °C		185	-		
	25 °C		165	-		
Self Refresh Current: Self refresh mode, quarter array activation (PASR = 010)	85 °C		285	325		
	70 °C		210	-		
	45 °C		155	-		
	25 °C		140	-		

1) $0\text{ °C} \leq T_C \leq 70\text{ °C}$ (comm.); $-25\text{ °C} \leq T_C \leq 85\text{ °C}$ (ext.); $V_{DD} = V_{DDQ} = 1.8\text{ V} \pm 0.15\text{ V}$

2) The On-Chip Temperature Sensor (OCTS) adjusts the refresh rate in self refresh mode to the component's actual temperature with a much finer resolution than supported by the 4 distinct temperature levels as defined by JEDEC for TCSR. At production test the sensor is calibrated, and I_{DD6} max. current is measured at 85°C. Typ. values are obtained from device characterization.

3.4 Pullup and Pulldown Characteristics

Table 23 Half Drive Strength (Default) and Full Drive Strength

Voltage (V)	Half Drive Strength (Default)				Full Drive Strength			
	Pull-Down Current (mA)		Pull-Up Current (mA)		Pull-Down Current (mA)		Pull-Up Current (mA)	
	Nominal Low	Nominal High	Nominal Low	Nominal High	Nominal Low	Nominal High	Nominal Low	Nominal High
0.00	0.0	0.0	-19.7	-33.4	0.0	0.0	-39.3	-66.7
0.40	15.1	20.5	-18.8	-32.0	30.2	41.0	-37.6	-63.9
0.65	20.3	28.5	-18.2	-31.0	40.5	57.0	-36.4	-61.9
0.85	22.0	32.0	-17.6	-29.9	43.9	64.0	-35.1	-59.8
1.00	22.6	33.5	-16.7	-28.7	45.2	67.0	-33.3	-57.3
1.40	23.5	35.0	-9.4	-20.4	46.9	70.0	-18.8	-40.7
1.50	23.6	35.3	-6.6	-17.1	47.2	70.5	-13.2	-34.1
1.65	23.8	35.5	-1.8	-11.4	47.5	71.0	-3.5	-22.7
1.80	23.9	35.7	3.8	-4.8	47.7	71.4	7.5	-9.6
1.95	24.0	35.9	9.8	2.5	48.0	71.8	19.6	5.0

The above characteristics are specified under nominal process variation / condition Temperature (T): Nominal = 50 °C, V_{DDQ} : Nominal = 1.80 V

4 Package Outlines

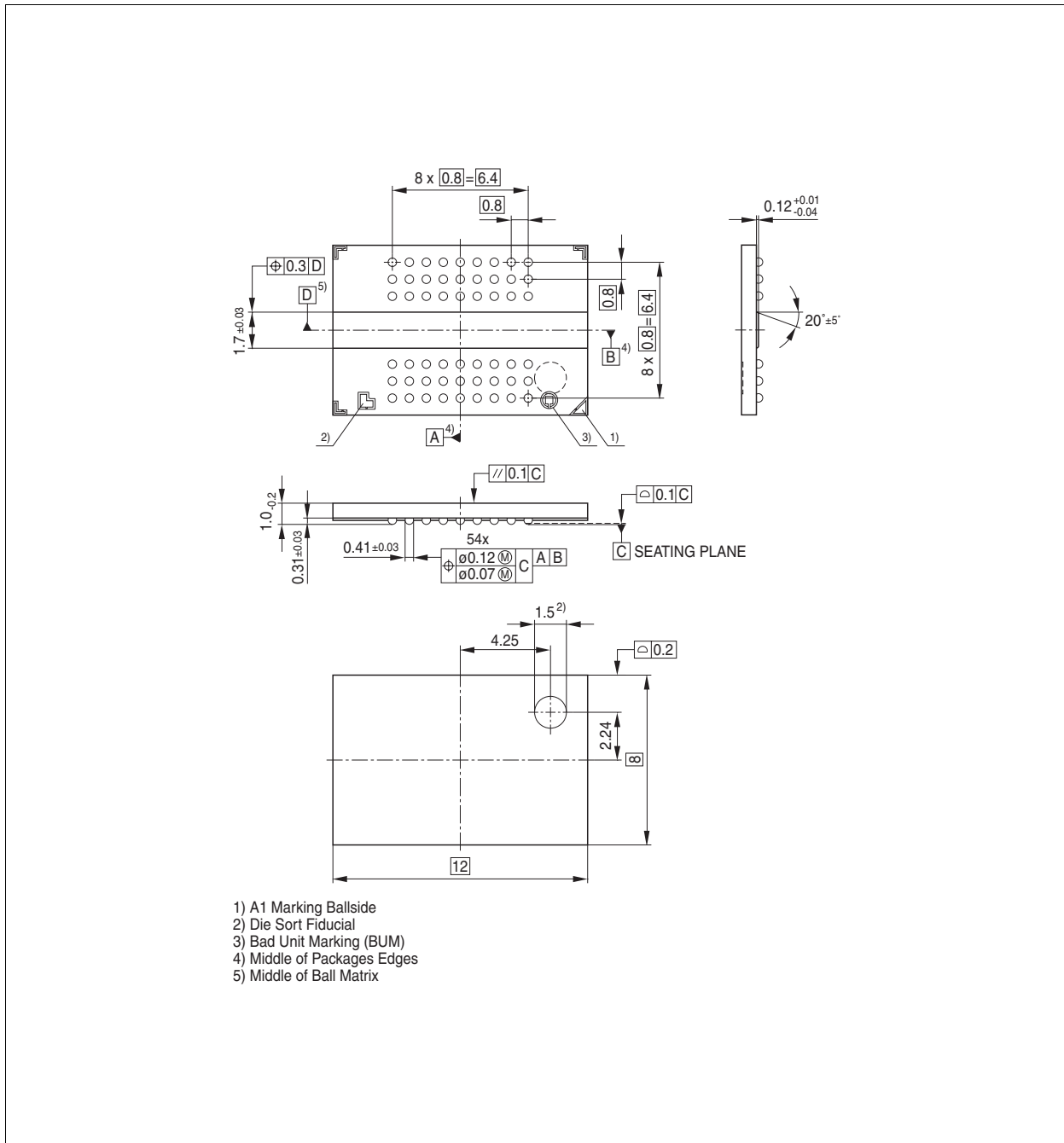

Figure 47 P-VFBGA-54-2 (Plastic Very Thin Fine Ball Grid Array Package)

You can find all of our packages, sorts of packing and others in our Infineon Internet Page "Products": <http://www.infineon.com/products>.

SMD = Surface Mounted Device

Dimensions in mm

www.infineon.com

Published by Infineon Technologies AG