

## SoundFusion<sup>®</sup> Audio/Modem Codec '97(AMC'97)

### FEATURES

- AC '97 2.0 compatible
- 20-bit stereo output and 18-bit stereo input codec with fixed 48 kHz sampling rate
- 20-bit output and 18-bit input dual modem AFE with fixed 48 kHz sampling rate
- Dedicated ADC for handset or speakerphone
- Four analog line-level stereo inputs for connection from LINE IN, CD, VIDEO, and AUX
- High quality pseudo-differential CD input
- Dual stereo line level output with independent 6-bit volume control
- 10 General Purpose I/O pins for Modem DAA controls
- IEC-958 Digital Output (S/PDIF)
- Meets or exceeds Microsoft's<sup>®</sup> PC 98 and PC 99 audio performance requirements
- CrystalClear<sup>™</sup> 3D Stereo Enhancement

### DESCRIPTION

The CS4298 is an AC '97 compatible Audio/Modem Codec designed for PC multimedia systems. Using the industry leading CrystalClear<sup>™</sup> delta-sigma and mixed signal technology, the CS4298 is ideal for PC 98-compliant desktop, notebook, and entertainment PCs, where high-quality audio and modem features are required. The CS4298 offers four channels of D/A and A/D conversion along with analog mixing and 3D processing. For multi-channel audio systems, the CS4298 can provide four audio channels. For combined audio/modem systems, the CS4298 can provide a modem AFE, voice codec, and stereo audio codec..

### ORDERING INFORMATION

CS4298-KQ	64-pin TQFP	10x10x1.4mm
CS4298-JQ	64-pin TQFP	10x10x1.4mm

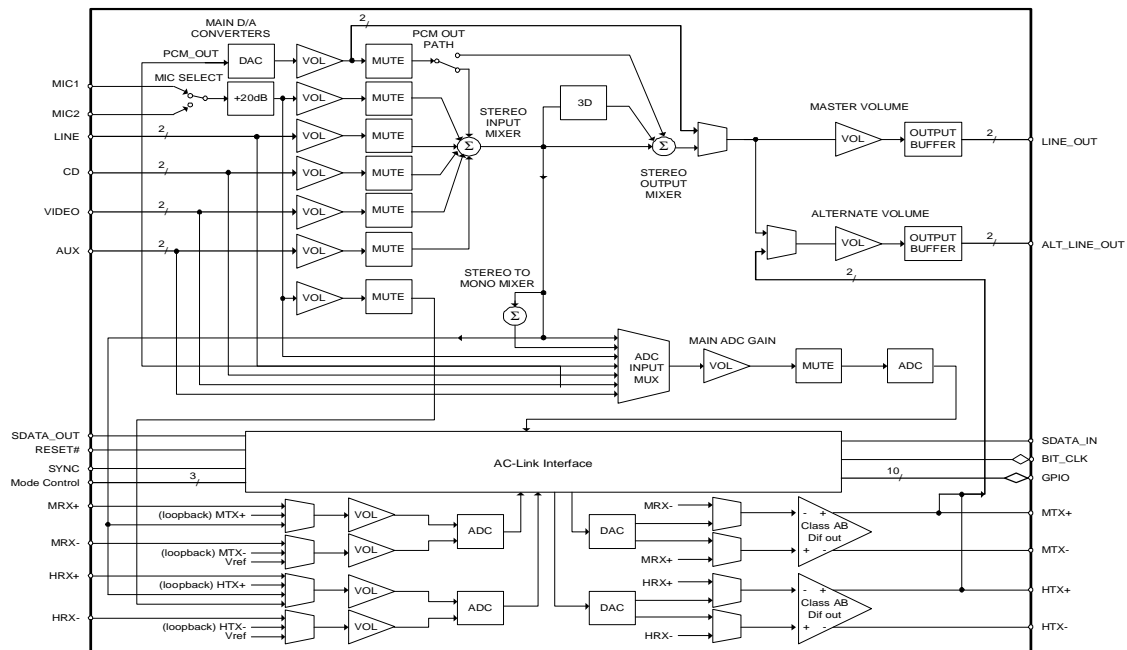

*Preliminary Product Information*

This document contains information for a new product. Cirrus Logic reserves the right to modify this product without notice.

**TABLE OF CONTENTS**

<b>1. CHARACTERISTICS AND SPECIFICATIONS .....</b>	<b>5</b>
AUDIO ANALOG CHARACTERISTICS.....	5
ABSOLUTE MAXIMUM RATINGS .....	6
RECOMMENDED OPERATING CONDITIONS .....	6
MIXER CHARACTERISTICS.....	6
MODEM CHARACTERISTICS .....	7
SERIAL PORT TIMING.....	9
<b>2. GENERAL DESCRIPTION .....</b>	<b>12</b>
2.1 Overview .....	12
2.2 Modes of Operation .....	12
2.2.1 Mode 0 .....	12
2.2.2 Mode 1 .....	12
2.2.3 Mode 2 .....	12
2.2.4 Mode 3 .....	12
<b>3. DIGITAL SECTION .....</b>	<b>13</b>
3.1 AC-Link .....	13
3.2 Control registers.....	13
<b>4. ANALOG SECTION .....</b>	<b>14</b>
4.1 Audio Output Mixer .....	14
4.2 Audio Input Mux .....	14
4.3 Audio Input Mixer .....	14
4.4 Audio Volume Control.....	14
<b>5. AC '97 .....</b>	<b>16</b>
5.1 AC '97 Frame Definition.....	16
5.2 AC-Link Serial Data Output Frame .....	16
5.3 AC-Link AudioOutput Frame.....	17
5.3.1 Serial Data Output Slot Tags (Slot 0).....	17
5.3.2 Register Address (Slot 1).....	17
5.3.3 Register Write Data (Slot 2).....	18
5.3.4 Playback Data (Slots 3-11) .....	18
5.3.5 GPIO Data (Slot12).....	18
5.4 AC-Link Audio Input Frame.....	18
5.4.1 Serial Data Input Slot Tag Bits (Slot 0) .....	18
5.4.2 Read-Back Address Port (Slot 1).....	19
5.4.3 Read-Back Data Port (Slot 2) .....	19
5.4.4 PCM Capture Data (Slot 3-11).....	19
5.4.5 GPIO Pin Status (Slot 12).....	19

---

**Contacting Cirrus Logic Support**

For a complete listing of Direct Sales, Distributor, and Sales Representative contacts, visit the Cirrus Logic web site at:  
<http://www.cirrus.com/corporate/contacts/>

---

Preliminary product information describes products which are in production, but for which full characterization data is not yet available. Advance product information describes products which are in development and subject to development changes. Cirrus Logic, Inc. has made best efforts to ensure that the information contained in this document is accurate and reliable. However, the information is subject to change without notice and is provided "AS IS" without warranty of any kind (express or implied). No responsibility is assumed by Cirrus Logic, Inc. for the use of this information, nor for infringements of patents or other rights of third parties. This document is the property of Cirrus Logic, Inc. and implies no license under patents, copyrights, trademarks, or trade secrets. No part of this publication may be copied, reproduced, stored in a retrieval system, or transmitted, in any form or by any means (electronic, mechanical, photographic, or otherwise) without the prior written consent of Cirrus Logic, Inc. Items from any Cirrus Logic webbieist or disk may be printed for use by the user. However, no part of the printout or electronic files may be copied, reproduced, stored in a retrieval system, or transmitted, in any form or by any means (electronic, mechanical, photographic, or otherwise) without the prior written consent of Cirrus Logic, Inc. Furthermore, no part of this publication may be used as a basis for manufacture or sale of any items without the prior written consent of Cirrus Logic, Inc. The names of products of Cirrus Logic, Inc. or other vendors and suppliers appearing in this document may be trademarks or service marks of their respective owners which may be registered in some jurisdictions. A list of Cirrus Logic, Inc. trademarks and service marks can be found at <http://www.cirrus.com>.

5.5 AC '97 Reset Modes.....	20
5.5.1 Cold AC '97 Reset.....	20
5.5.2 Warm AC '97 Reset .....	20
5.5.3 AC '97 Register Reset.....	20
5.6 AC-Link Protocol Violation - Loss of SYNC .....	20
<b>6. REGISTER INTERFACE .....</b>	<b>21</b>
6.1 Register Descriptions .....	23
6.1.1 Reset (Index 00h) .....	23
6.1.2 Master Volume (Index 02h) .....	23
6.1.3 Alternate Volume (Index 04h) .....	24
6.1.4 Microphone Volume (Index 0Eh) .....	24
6.1.5 Stereo Analog Mixer Input Gain (Index's 10h - 18h) .....	25
6.1.6 Input Mux Select (Index 1Ah) .....	25
6.1.7 Record Gain (Index 1Ch).....	26
6.1.8 Record Gain Microphone (Index 1Eh).....	26
6.1.9 General Purpose (Index 20h) .....	26
6.1.10 3D Control (Index 22h) .....	26
6.1.11 Power Down Control/Status (Index 26h) .....	27
6.1.12 Extended Audio ID (Index 28h) .....	28
6.1.13 Extended Audio Status / Control (Index 2Ah) .....	28
6.1.14 PCM Front DAC Rate (Index 2Ch) .....	29
6.1.15 PCM Surround DAC Rate (Index 2Eh) .....	29
6.1.16 PCM LFE DAC Rate (Index 30h) .....	29
6.1.17 PCM LR ADC Rate (Index 32h).....	29
6.1.18 PCM MIC ADC Rate (Index 34h).....	29
6.1.19 Center LFE Volume (Index 36h).....	30
6.1.20 LR Surround Volume (Index 38h).....	30
6.1.21 Extended Modem ID (Index 3Ch) .....	30
6.1.22 Extended Modem ID (Index 3Eh) .....	31
6.1.23 Line 1 DAC/ADC Rate (Index 40h).....	31
6.1.24 Line 2 DAC/ADC Rate (Index 42h).....	31
6.1.25 Handset DAC/ADC Rate (Index 44h) .....	32
6.1.26 Line 1 DAC/ADC Level (Index 46h).....	32
6.1.27 Line 2 DAC/ADC Level (Index 48h).....	32
6.1.28 Handset DAC/ADC Level (Index 4Ah).....	32
6.1.29 GPIO Pin Configuration (Index 4Ch) .....	33
6.1.30 GPIO Pin Polarity/Type Configuration (Index 4Eh) .....	33
6.1.31 GPIO Pin Sticky (Index 50h).....	33
6.1.32 GPIO Pin Wakeup Mask (Index 4Ch).....	34
6.1.33 GPIO Pin Status (Index 54h).....	34
6.1.34 Misc. Modem AFE Status (Index 56h) .....	34
6.1.35 AC Mode Control (Index 5Eh) .....	35
6.1.36 S/PDIF Control (Index 68h) .....	35
6.1.37 Vendor ID1 (Index 7Ch).....	36
6.1.38 Vendor ID2 (Index 7Eh).....	36
<b>7. ANALOG HARDWARE DESCRIPTION .....</b>	<b>37</b>
7.1 Line-Level Inputs .....	37
7.2 Microphone Level Inputs .....	38
7.3 Line Level Outputs.....	38
7.4 Consumer IEC-958 Digital Interface (S/PDIF).....	39
7.5 Miscellaneous Analog Signals.....	39
7.6 Power Supplies.....	40
7.7 Hybrid Interface .....	41

---

<b>8. PIN DESCRIPTIONS .....</b>	<b>42</b>
8.1 g2 .....	43
8.2 Analog I/O Pins .....	45
8.3 Filter and Reference Pins .....	46
8.4 Modem/Telephony .....	47
8.5 Power Supplies .....	48
<b>9. PARAMETER AND TERM DEFINITIONS .....</b>	<b>49</b>
<b>10. REFERENCES .....</b>	<b>50</b>
<b>11. PACKAGE DIMENSIONS .....</b>	<b>51</b>

## LIST OF FIGURES

Figure 1. Power Up Timing.....	10
Figure 2. Clocks .....	10
Figure 3. Codec Ready from Startup or Fault Condition .....	10
Figure 4. Data Setup and Hold.....	11
Figure 5. PR4 Powerdown .....	11
Figure 6. Test Mode .....	11
Figure 7. AC-link Connections.....	13
Figure 8. Mixer Diagram.....	15
Figure 9. AC-link Input and Output Framing.....	16
Figure 10. Line Inputs.....	37
Figure 11. Differential CDRom In .....	37
Figure 12. PC '99 Microphone Pre-amplifier .....	38
Figure 13. Headphones Driver .....	39
Figure 14. IEC-958 Interface Examples .....	40
Figure 15. Voltage Regulator .....	40
Figure 16. Hybrid Circuit Secondary .....	41

## LIST OF TABLES

Table 1. Mixer Registers .....	21
Table 2. Alternate Line-Out and Master Mono Attenuation .....	24
Table 3. Analog Mixer Input Gain Values.....	24
Table 4. Stereo Volume Register Index .....	25
Table 5. Input Mux Selection.....	25
Table 6. 6 Channel Volume Attenuation.....	30
Table 7. GPIO Input/Output Configuration .....	33
Table 8. Misc. Modem Configuration.....	34
Table 9. Slot Assignments.....	35
Table 10. Reg. 7Eh Defined Part ID's .....	36

# 1. CHARACTERISTICS AND SPECIFICATIONS

## AUDIO ANALOG CHARACTERISTICS

(Standard test conditions unless otherwise noted:

$T_{\text{ambient}} = 25^{\circ} \text{C}$ ,  $AV_{\text{dd}} = 5.0 \text{V} \pm 5\%$ ,  $DV_{\text{dd}} = 3.3 \text{V} \pm 5\%$ ; 1 kHz Input Sine wave; Sample Frequency,  $F_s = 48 \text{kHz}$ ;  $Z_{\text{AL}} = 10 \text{k}\Omega / 680 \text{pF}$  load  $C_{\text{DL}} = 18 \text{pF}$  load (Note 1); Measurement bandwidth is 20 Hz - 20 kHz, 18-bit linear coding for ADC, 20-bit linear coding for DAC; Mixer registers set for unity gain.

Parameter (Note 2)	Symbol	Path (Note 3)	CS4298-KQ			CS4298-JQ			Unit
			Min	Typ	Max	Min	Typ	Max	
Full Scale Analog Input Voltage									
Line Inputs		A-D	0.91	1.00	-	0.91	1.00	-	$V_{\text{RMS}}$
Mic Inputs (20 dB=0)		A-D	0.91	1.00	-	0.91	1.00	-	$V_{\text{RMS}}$
Mic Inputs (20 dB=1)		A-D	0.091	0.10	-	0.091	0.10	-	$V_{\text{RMS}}$
Full Scale Output Voltage (Note 4)									
Line and Alternate Line Outputs		D-A	0.91	1.0	1.13	0.91	1.0	1.13	$V_{\text{RMS}}$
Frequency Response									
Analog $A_c = \pm 0.5 \text{dB}$	FR	A-A	20	-	20,000	20	-	20,000	Hz
DAC $A_c = \pm 0.5 \text{dB}$		D-A	20	-	20,000	20	-	20,000	Hz
ADC $A_c = \pm 0.5 \text{dB}$		A-D	20	-	20,000	20	-	20,000	Hz
Dynamic Range									
Stereo Analog inputs to LINE_OUT	DR	A-A	90	95	-	-	90	-	dB FS A
Mono Analog inputs to LINE_OUT		A-A	85	90	-	-	85	-	dB FS A
DAC Dynamic Range		D-A	85	90	-	-	87	-	dB FS A
ADC Dynamic Range		A-D	85	90	-	-	85	-	dB FS A
DAC SNR (-20 dB FS input w/ CCIR-RMS filter on output)	SNR	D-A	-	63	-	-	-	-	dB
Total Harmonic Distortion + Noise (-3 dB FS input signal):									
Line/Alternate Line Output	THD+N	A-A	-	-94	-80	-	-	-74	dB FS A
DAC		D-A	-	-86	-80	-	-	-74	dB FS A
ADC (all inputs except phone/mic)		A-D	-	-87	-80	-	-	-74	dB FS A
ADC (phone/mic)		A-D	-	-87	-74	-	-	-74	dB FS A
Power Supply Rejection Ratio (1 kHz, $0.5 V_{\text{RMS}}$ w/ 5 V DC offset)(Note 5)			40	60	-	-	40	-	dB
Interchannel Isolation			70	87	-	-	87	-	dB
Spurious Tone (Note 5)			-	-100	-	-	-100	-	dB FS
Input Impedance (Note 5)			10	-	-	10	-	-	k $\Omega$
External Load Impedance			10	-	-	10	-	-	k $\Omega$
Output Impedance (Note 5)			-	730	-	-	730	-	W
Input Capacitance (Note 5)			-	5	-	-	5	-	pF
Vrefout			2.0	2.3	2.4	2.0	2.3	2.4	V

- Notes:
1.  $Z_{\text{AL}}$  refers to the analog output pin loading and  $C_{\text{DL}}$  refers to the digital output pin loading.
  2. Parameter definitions are given in the *Parameter and Term Definitions* section.
  3. Path refers to the signal path used to generate this data. These paths are defined in the *Parameter and Term Definition* section.
  4. Typical measured with  $Z_{\text{AL}} = 47 \text{k}\Omega / 680 \text{pF}$  load.
  5. This specification is guaranteed by silicon characterization, it is not production tested.

**ABSOLUTE MAXIMUM RATINGS** (AVss1 = AVss2 = DVss1 = DVss2 = 0 V)

Parameter	Min	Typ	Max	Unit	
Power Supplies	+3.3 V Digital	-0.3	-	6.0	V
	+5 V Digital	-0.3	-	6.0	V
	Analog	-0.3	-	6.0	V
Total Power Dissipation (Supplies, Inputs, Outputs)	-	-	750	mW	
Input Current per Pin (Except Supply Pins)	-10	-	10	mA	
Output Current per Pin (Except Supply Pins)	-15	-	15	mA	
Analog Input voltage	-0.3	-	AVdd+0.3	V	
Digital Input voltage	-0.3	-	DVdd + 0.3	V	
Ambient Temperature (Power Applied)	-55	-	110	°C	
Storage Temperature	-65	-	150	°C	

**RECOMMENDED OPERATING CONDITIONS** (AVss1 = AVss2 = DVss1 = DVss2 = 0 V)

Parameter	Symbol	Min	Typ	Max	Unit	
Power Supplies	+3.3 V Digital	DVdd1, DVdd2	3.135	3.3	3.465	V
	+5 V Digital	DVdd1, DVdd2	4.75	5	5.25	V
	Analog	AVdd1, AVdd2	4.75	5	5.25	V
Operating Current	+3.3 V Digital	DVdd1, DVdd2		40	52	mA
	+5 V Digital	DVdd1, DVdd2		40	52	mA
	Analog	AVdd1, AVdd2		75	97.5	mA
Operating Ambient Temperature		0	-	70	°C	

**MIXER CHARACTERISTICS** (for CS4298-KQ only)

Parameter	Min	Typ	Max	Unit	
Mixer Gain Range Span	Line In, Aux, CD, Video, Mic1 Mic2,	-	46.5	-	dB
	Line Out, Alternate Line Out	-	94.5	-	dB
Step Size	All volume controls	-	1.5	-	dB

**MODEM CHARACTERISTICS** (Analog Transmitter Specifications:  $T_{\text{ambient}} = 0^{\circ}$  to  $70^{\circ}$  C,  $AV_{\text{dd}} = 5.0$  V; Sample Frequency,  $F_s = 48$  kHz; Audio specifications for 20Hz - 5 kHz, actual digital filter may cutoff at 20 kHz, 600  $\Omega$  differential load where applicable)

Parameter	Min	Typical	Max	Units
<b>Modem Analog Transmitter Characteristics</b>				
Resolution	20			bits
Dynamic Range (Note 5)		100		dB FS
Passband	20		5000	Hz
Passband Ripple			$\pm 0.125$	dB1K
Total Harmonic Distortion	85	88		dB FS
Full Scale Peak to Peak Output Voltage (TX+ to TX-)	TBD	5.6	TBD	Volts
AC Output Impedance (TX+, TX-) (Note 5)		0.1		W
Load Impedance (per pin) (Note 5)	250			W
Power Supply Rejection (1kHz) (Note 5)		60		dB
Output Current (per pin)		7.4		mA
Offset (relative) (Note 5)		6		mV
Out of Band specifications ( $T_{\text{ambient}} = 25^{\circ}$ C, $AV_{\text{dd}} = 5$ V; Sample Frequency, $F_s = 48$ kHz; measurement bandwidth 20 kHz - 1MHz, $R_L = 600 \Omega$ , $C_L = 33\text{nF}$ ) (Note 5)		-40		dB FS
Total Out of Band energy (20 kHz - 1 MHz) (Note 5)			-30	dBV
Highest 9kHz band (noise + tone) power (90 kHz - 2 MHz) (Note 5, 6)			-55	dBV
<b>Modem Analog Receiver Characteristics</b>				
Resolution	18			bits
Dynamic Range Gain = 0		90		dB FS
Passband	20		5000	Hz
Passband Ripple			$\pm 0.125$	dB1K
Total Harmonic Distortion Gain = 0		85		dB FS
Total Absolute Gain Accuracy	-5		+5	%
Full Scale Peak to Peak Input Voltage (RX+ to RX-, differential) Gain = 0		2.8		Volts
Input Impedance (per pin) (Note 5)		15		K $\Omega$
Offset (relative) (Note 5)		6		mV
Power Supply Rejection (Note 5)	40	60		dB

Notes: 6. This is the FCC specification for Out-of-Band energy at the telephone jack interface. 9 kHz refers to the bin size of an FFT performed over the entire range. The amount of noise plus tone power in each 8kHz bin must be less than -55dBV.

**DIGITAL CHARACTERISTICS** ( $A_{Vss} = D_{Vss} = 0\text{ V}$ )

Parameter	Symbol	Min	Typ	Max	Unit
<b><i>DVdd = 3.3V</i></b>					
Low level input voltage	$V_{il}$			0.8	V
High level input voltage	$V_{ih}$	2.15			V
High level output voltage	$V_{oh}$	3.0	3.25		V
Low level output voltage	$V_{ol}$		0.03	.35	V
Input Leakage Current (AC-link inputs)		-10	-	10	$\mu\text{A}$
Output Leakage Current (Tri-stated AC-link outputs)		-10	-	10	$\mu\text{A}$
Output buffer drive current					
BIT_CLK			24		mA
SDATA_IN, EAPD			4		mA
S/PDIF_OUT (Note 5)			12.5		mA
<b><i>DVdd = 5.0 V</i></b>					
Low level input voltage	$V_{il}$			0.8	V
High level input voltage	$V_{ih}$	3.25			V
High level output voltage	$V_{oh}$	4.5	4.95		V
Low level output voltage	$V_{ol}$	-	0.03	.35	V
Input Leakage Current (AC-link inputs)		-10	-	10	$\mu\text{A}$
Output Leakage Current (Tri-stated AC-link outputs)		-10	-	10	$\mu\text{A}$
Output buffer drive current					
BIT_CLK			24		mA
SDATA_IN, EAPD			4		mA
S/PDIF_OUT (Note 5)			12.5		mA



**SERIAL PORT TIMING**

Parameter	Symbol	Min	Typ	Max	Unit
<b>RESET# Timing</b>					
Vdd stable to RESET# inactive	$T_{vdd2rst\#}$	5	.		ms
RESET# active low pulse width	$T_{rst\_low}$	1.0	-	-	$\mu$ s
RESET# inactive to BIT_CLK start-up delay	$T_{rst2clk}$	25	120	-	$\mu$ s
1st SYNC active to CODEC READY set	$T_{sync2crd}$	-	62.4	-	$\mu$ s
<b>Clocks</b>					
BIT_CLK frequency	$F_{clk}$	-	12.288	-	MHz
BIT_CLK period	$T_{clk\_period}$	-	81.4	-	ns
BIT_CLK output jitter (depends on XTAL_IN source)		-	-	750	ps
BIT_CLK high pulse width	$T_{clk\_high}$	36	40.7	45	ns
BIT_CLK low pulse width	$T_{clk\_low}$	36	40.7	45	ns
SYNC frequency	$F_{sync}$	-	48	-	kHz
SYNC period	$T_{sync\_period}$	-	20.8	-	$\mu$ s
SYNC high pulse width	$T_{sync\_high}$	-	1.3	-	$\mu$ s
SYNC low pulse width	$T_{sync\_low}$	-	19.5	-	$\mu$ s
<b>Data Setup and Hold</b>					
Output Propagation delay from rising edge of BIT_CLK	$T_{co}$	-	6	12	ns
Input setup time from falling edge of BIT_CLK	$T_{isetup}$	10	-	-	ns
Input hold time from falling edge of BIT_CLK	$T_{ihold}$	0	-	-	ns
Input Signal rise time	$T_{irise}$	2	-	6	ns
Input Signal fall time	$T_{ifall}$	2	-	6	ns
Output Signal rise time (Note 5, 7)	$T_{orise}$	2	4	6	ns
Output Signal fall time (Note 5, 7)	$T_{ofall}$	2	4	6	ns
<b>Misc. Timing Parameters</b>					
End of Slot 2 to BIT_CLK, SDATA_IN low (PR4)	$T_{s2\_pdown}$	-	.34	1.0	$\mu$ s
SYNC pulse width (PR4) Warm Reset	$T_{sync\_pr4}$	1.1	-	-	$\mu$ s
SYNC inactive (PR4) to BIT_CLK start-up delay	$T_{sync2clk}$	162.8	350	-	ns
Setup to trailing edge of RESET# (test mode) (Note 5)	$T_{setup2rst}$	15	-	-	ns
Rising edge of RESET# to Hi-Z delay (Note 5)	$T_{off}$	-	-	25	ns

Notes: 7. BIT\_CLK measured with 47  $\Omega$  series termination and  $C_L = 50$  pF.

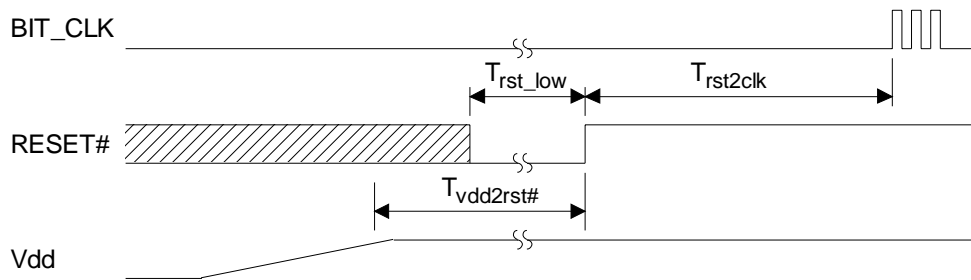

**Figure 1. Power Up Timing**

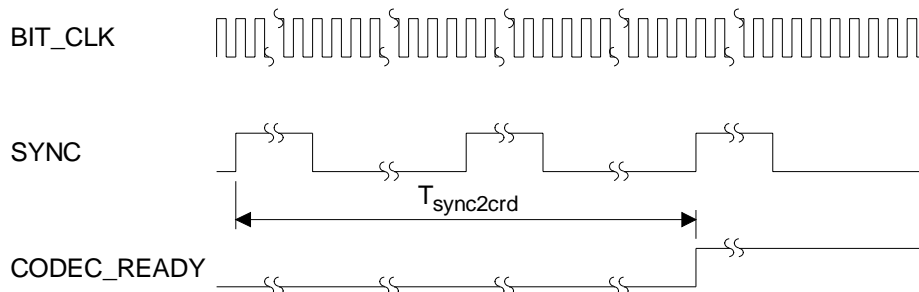

**Figure 2. Clocks**

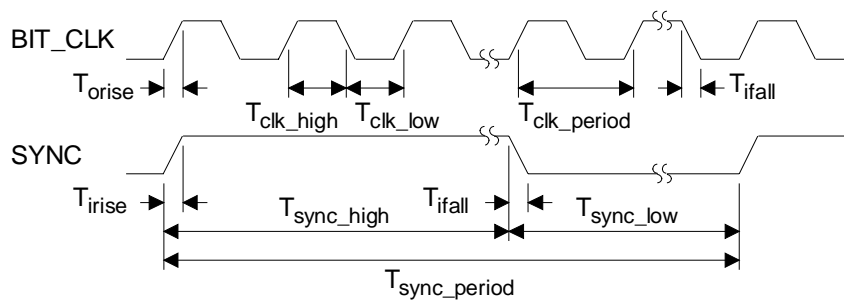

**Figure 3. Codec Ready from Startup or Fault Condition**

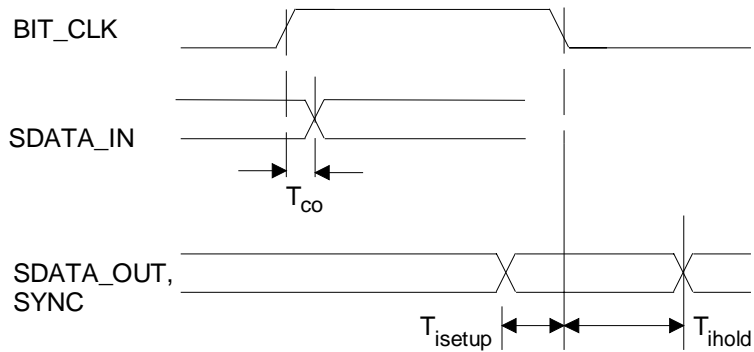

**Figure 4. Data Setup and Hold**

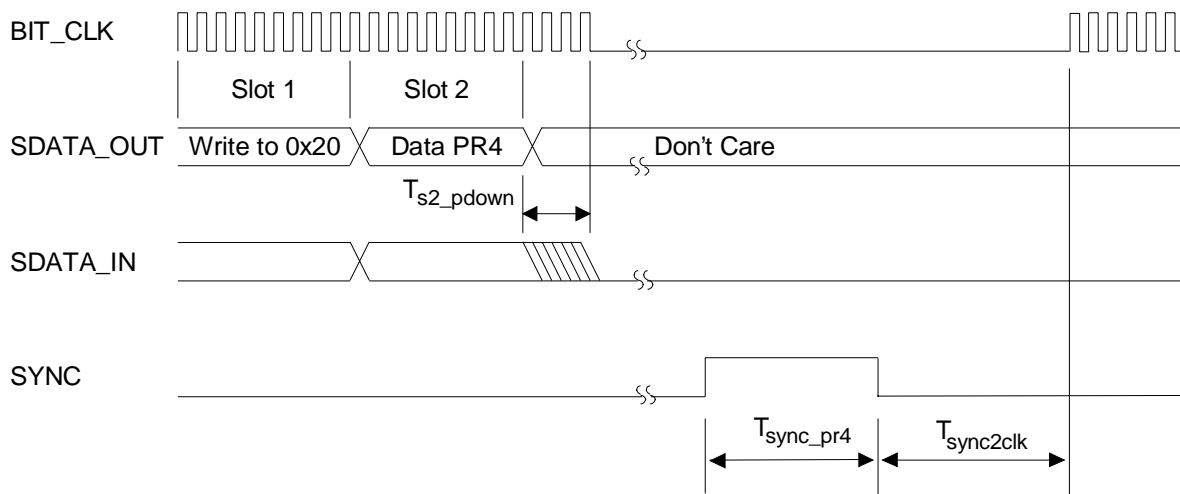

**Figure 5. PR4 Powerdown**

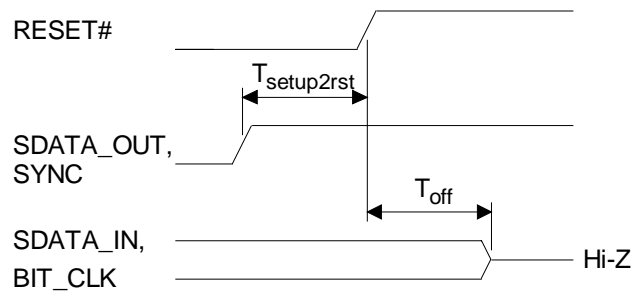

**Figure 6. Test Mode**

---

## 2. GENERAL DESCRIPTION

### 2.1 Overview

The CS4298 is a Mixed-Signal Audio/Modem Codec (AMC) based on the AC '97 1.0 Specification, and the AC '97 2.0 Extensions. It is designed to be paired with a digital controller, typically located on the PCI bus. The AMC Controller is responsible for all communications between the CS4298 and the rest of the system. The CS4298 functions as an analog mixer, a stereo audio ADC, a stereo audio DAC, a dual modem AFE, and a control and digital stream interface to the AMC Controller. The CS4298 contains three distinct functional sections: Digital, Analog Audio, and Analog Modem.

The Digital Section includes the AC-Link registers, power management support, SYNC detection circuitry, and AC-Link serial port interface logic. The Analog Audio section includes the analog input multiplexor (mux), stereo output mixer, stereo ADCs, stereo DACs, and analog volume controls. The Analog Modem section includes dual differential ADCs, dual differential DACs, analog loop-back logic, GPIO control and status, and power down and wake-up logic.

### 2.2 Modes of Operation

The CS4298 has four basic modes of operation. Each mode allows varying functionality to meet a wide variety of software and hardware configurations. On power up or system reset, the device reverts to the basic configuration Mode 0. The audio ADC's and DAC's functionality remains fixed for each mode, but the modem ADC's and DAC's functionality changes per each configuration. From a system perspective, the device can provide standard audio with modem, two line interface, speakerphone, and four channel enhanced audio.

#### 2.2.1 Mode 0

This is the default operating mode for the CS4298. It supports the legacy AC '97 audio modes of operation including audio mixer, ADC's, and DAC's. The modem configuration supports a phone line for modem ADC/DAC1 and a handset interface for modem ADC/DAC2.

#### 2.2.2 Mode 1

This is the two phone line mode of operation. It is similar to mode 0 but the modem ADC/DAC2 is interfaced to a second phone line in place of the handset.

#### 2.2.3 Mode 2

This mode facilitates a full duplex speakerphone mode of operation. The ADC of modem ADC/DAC2 is connected directly to the audio microphone in place of the handset or line 2 input. This dedicated microphone capture path allows the host controller to implement echo cancellation for hands free telephone operation. The modem DAC2 is not used in this mode.

#### 2.2.4 Mode 3

Mode 3 is the four channel expansion mode. The modem ADC/DAC pairs are utilized for enhanced audio functionality. The modem DAC's are routed to the alternate line audio outputs providing 2 additional audio channels. The modem ADC inputs may be connected to the output of the analog stereo input mixer for enhanced audio effect processing or enhanced digital docking in a note book application.

### 3. DIGITAL SECTION

#### 3.1 AC-Link

All communication with the Codec is established with a 5-wire digital interface to the Controller chip as shown in Figure 7. All clocking for the serial communication is synchronous to the BIT\_CLK signal. BIT\_CLK is generated by the primary Codec and is used to slave the Controller and any secondary Codecs, if applicable. An AC-link audio frame is a sequence of 256 serial bits organized into 13 groups referred to as 'slots'. One frame consists of one 16-bit slot and twelve 20-bit slots. During each audio frame, data is passed bi-directionally between the Codec and the Controller. The input frame is driven from the Codec on the SDATA\_IN line. The

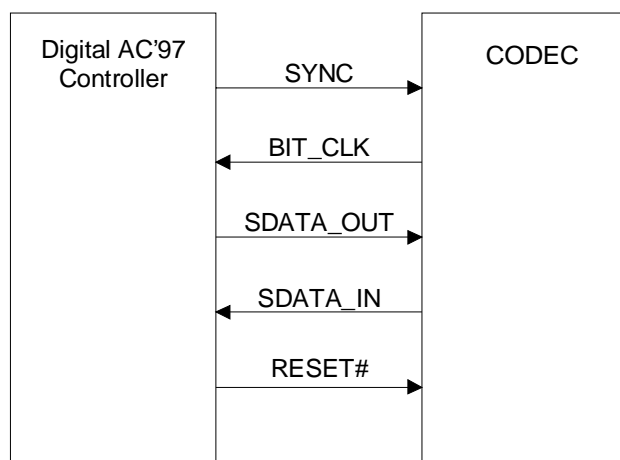

**Figure 7. AC-link Connections**

output frame is driven from the Controller SDATA\_OUT line. Both input and output frames contain the same number of bits and are organized with the same 'slot' configuration. The input and output frame have differing functions for each slot. The Controller synchronizes the beginning of a frame with the SYNC signal. In Figure 9 the position of each bit location within the frame is noted. The first bit position in a new serial data frame is F0 and the last bit position in the serial data frame is F255. When SYNC goes active (high) and is sampled active by the CS4298 (on the falling edge of BIT\_CLK), both devices are synchronized to a new serial data frame. The data on the SDATA\_OUT pin at this clock edge is the final bit of the previous frame's serial data. On the next rising edge of BIT\_CLK, the first bit of Slot 0 is driven by the Controller on the SDATA\_OUT pin. The CS4298 latches in this data, as the first bit of the frame, on the next falling edge of the BIT\_CLK clock signal. The Controller is also responsible for issuing reset via the RESET# signal. After being reset, the Codec is responsible for flagging the Controller that it is ready for operation after synchronizing its internal functions. The AC-link signals may be referenced to either 5 Volts or 3.3 Volts. The CS4298 must use the same digital supply voltage as the Controller chip.

#### 3.2 Control registers

All read accesses to the Codec are generated by requesting a register address (index number) in slot 1 of a SDATA\_OUT frame. The following SDATA\_IN frame will contain the register content in its slot 2. The write operation is identical with the index in slot 1 and the write data in slot 2. The *AC '97 Frame Definition* section details the function of each input and output frame. Individual register descriptions are found in the *Register Interface* section.

##### AC-97 Register Interface

The CS4298 implements the AC '97 Registers in accordance with the AC '97 2.0 Specification. See the *Register Interface* section for details on the CS4298's register set.

## **4. ANALOG SECTION**

Please refer to Figure 8, Mixer diagram, for a high-level graphical representation of the CS4298 analog mixer structure.

### **4.1 Audio Output Mixer**

There are two output mixers on the CS4298. The stereo output mixer sums together the analog outputs from the Input Mixer, 3D enhancement, and the PCM DAC output. The stereo output mix is sent to the `LINE_OUT` and `ALT_LINE_OUT` output pins of the CS4298. When the device is set to Mode 3 or Mode 0-2 and the EAM in AC Mode Control (Index 5Eh) is set, the modem DAC outputs are routed to `ALT_LINE_OUT`.

### **4.2 Audio Input Mux**

The input multiplexor controls which analog input is sent to the ADCs. The output of the input mux is converted to stereo 18-bit digital PCM data and sent to the AMC Controller chip in Slots 3 and 4 of the AC-Link `SDATA_IN` signal.

### **4.3 Audio Input Mixer**

The input mixer is an analog mix of the analog input signals such as `MIC`, `LINE_IN`, etc., and the PCM Audio DAC output. The output of the mixer is routed to the ADC Input Mux, Audio Output Mixer, and may be routed to the Modem ADC input.

### **4.4 Audio Volume Control**

The volume control registers of the AC '97 Register interface control analog input level to the input mixer, the master volume level, and the alternate volume level. All analog volume controls implement volume steps at nominally 1.5 dB per step. The analog inputs allow a mixing range of +12 dB of signal gain to -34.5 dB of signal attenuation. The analog output volume controls allows from 0 dB to -94.5 dB of attenuation.

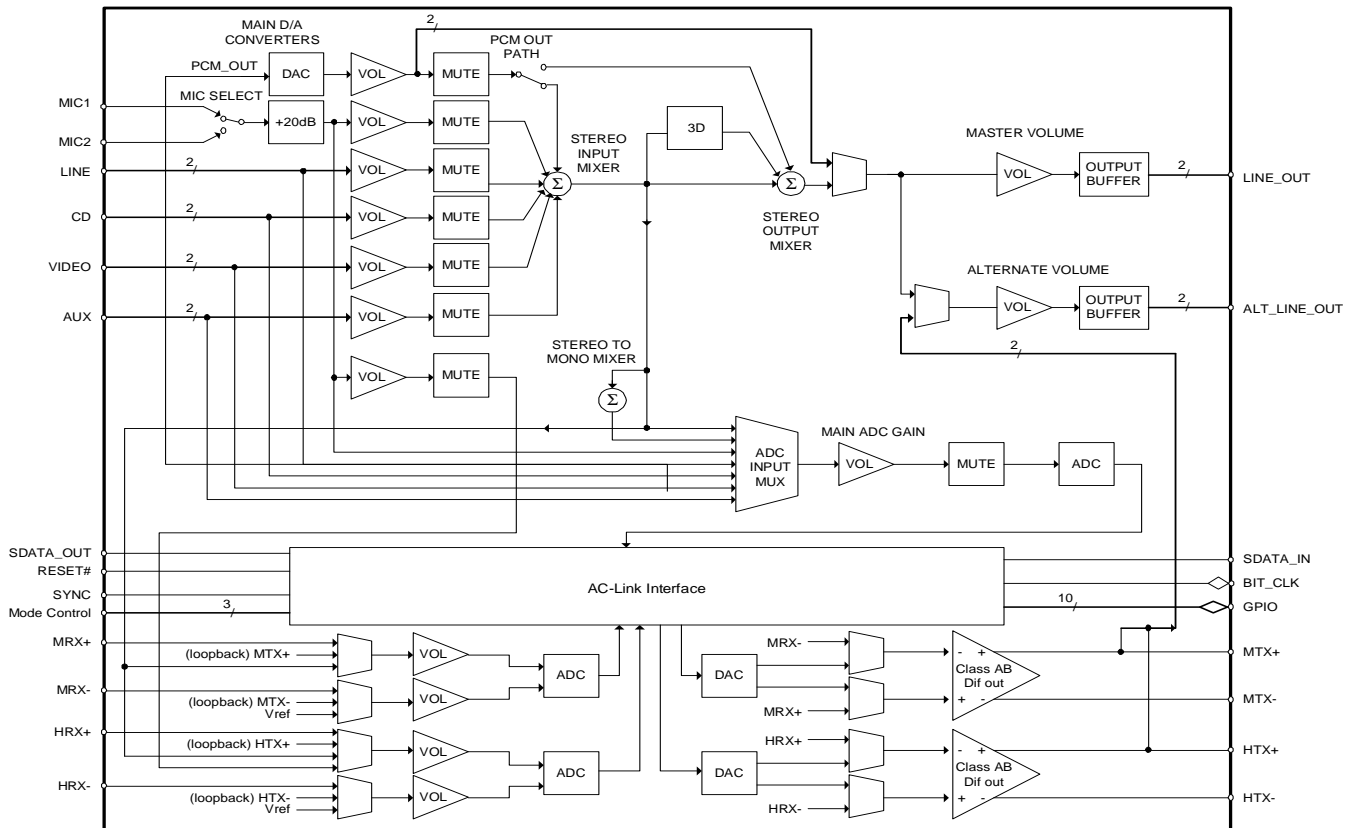

**Figure 8. Mixer Diagram**

**5. AC '97**

**5.1 AC '97 Frame Definition**

The AC Link is a bi-directional serial port with thirteen time-division multiplexed slots in each direction. The first slot is 16 bits long and termed the tag slot. Bits in the tag slot determine if the Codec is ready and indicate which, if any, other slots contain valid data. Slots 1 through 11 are 20-bits long and can contain audio data. Slot 12 contains data to be written and read from GPIO. The serial data line is defined from the Controller's perspective, NOT from the Audio Codec's perspective.

**5.2 AC-Link Serial Data Output Frame**

In the serial data output frame, data is passed on the SDATA\_OUT pin TO the CS4298 FROM the Controller. Figure 9 illustrates the serial port timing.

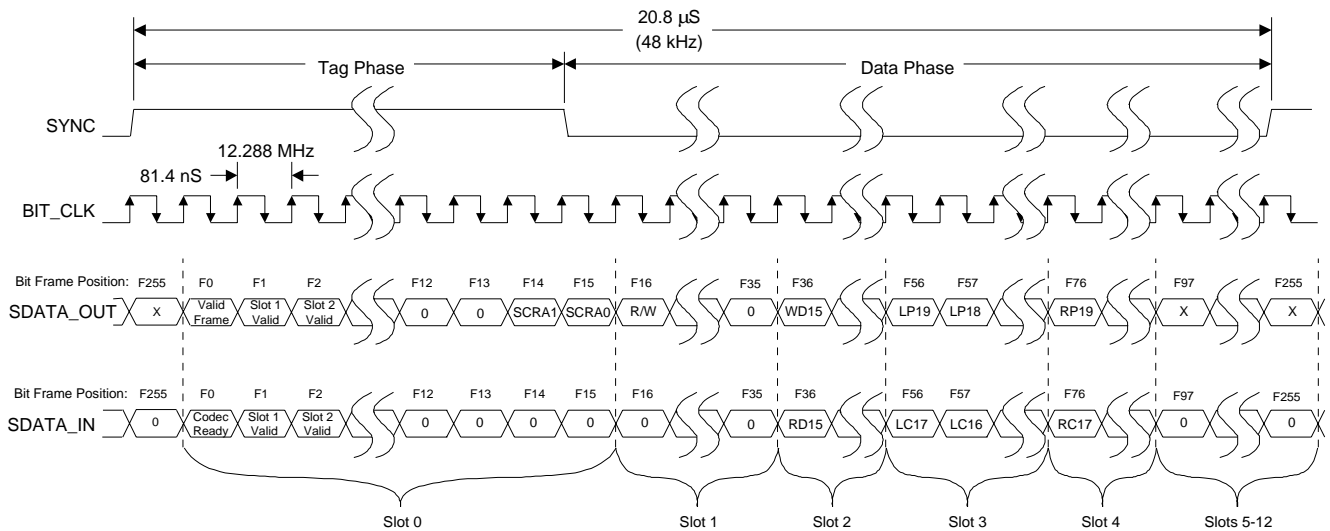

**Figure 9. AC-link Input and Output Framing**



### 5.3 AC-Link AudioOutput Frame

#### 5.3.1 Serial Data Output Slot Tags (Slot 0)

Bit 15	14	13	12	11	10	9	8	7	6	5	4	3	2	1	0
Valid Frame	Slot 1 Valid	Slot 2 Valid	Slot 3 Valid	Slot 4 Valid	Slot 5 Valid	Slot 6 Valid	Slot 7 Valid	Slot 8 Valid	Slot 9 Valid	Slot 10 Valid	Slot 11 Valid	Slot 12 Valid		SCRA 1	SCRA 0

**Valid Frame** Determines if any of the following slots contain either valid playback data for the Codec's DACs, data for read/write operation, or GPIO data. When set, at least one of the other AC-link slots contain valid data. If this bit is clear, the remainder of the frame is ignored.

**Slot [1:2] Valid** Indicates valid slot data when accessing the register set of the primary Codec (SCRA[1:0] = 00). For a read operation, Slot 1 Valid is set when *Register Address* (Slot 1) contains valid data. For a write operation, Slot 1 Valid and Slot 2 Valid are set indicating *Register Address* (Slot 1) and *Register Write Data* (Slot 2) contain valid data. The register address and write data must be valid within the same frame. SCRA[1:0] must be cleared when accessing the primary Codec. The physical address of a Codec is determined by the ID[1:0]# input pins which are reflected in the *Extended Audio ID* (Index 28h) register and the *Extended Modem ID* (Index 3Ch) register.

**Slot [3:11] Valid**

If a Slot Valid bit is set, the named slot contains valid audio data. If the bit is clear, the slot will be ignored. The definition of each slot is determined by the basic operating mode selected for the CS4298. For more information, see the *AC Mode Control* (Index 5Eh) register.

**Slot 12 Valid** If Slot 12 Valid is set, Slot 12 contains valid write data for the GPIO pins.

**SCRA[1:0]** Secondary Codec Register Access. Unlike the primary Codec, SCRA[1:0] indicate valid slot data when accessing the register set of a secondary Codec. The value set in SCRA[1:0] (01,10,11) determines which of the three possible secondary Codecs is accessed. For a read operation, the SCRA[1:0] bits are set when *Register Address* (Slot 1) contains valid data. For a write operation, SCRA[1:0] bits are set when *Register Address* (Slot 1) and *Register Write Data* (Slot 2) contain valid data. The write operation requires the register address and the write data to be valid within the same frame. SCRA[1:0] must be cleared when accessing the primary Codec. They must also be cleared during the idle period where no register read or write is pending. The physical address of a Codec is determined by the ID[1:0]# input pins which are reflected in the *Extended Audio ID* (Index 28h) register and the *Extended Modem ID* (Index 3Ch) register. The SCRA[1:0] bits are listed as the ID[1:0] bits in Slot 0 in the AC '97 specification.

#### 5.3.2 Register Address (Slot 1)

Bit 19	18	17	16	15	14	13	12	11	10	9	8	7	6	5	4	3	2	1	0
R/W#	RI6	RI5	RI4	RI3	RI2	RI1	RI0												

**R/W #** Read/Write#. Determines if a read (R/W# = 1) or write (R/W# = 0) operation is requested. For a read operation, the following Input Frame will return the register index in the *Read-Back Address Port* (Slot 1) and the contents of the register in the *Read-Back Data Port* (Slot 2). A write operation does not return any valid data in the following frame. If the R/W# bit = 0, data must be valid in both the *Register Address* (Slot 1) and the *Register Write Data* (Slot 2) during a frame when Slot [1:2] Valid or SCRA[1:0] are set.

**RI[6:0]** Register index/address. Registers can only be accessed on word boundaries; RI0 must be set to 0. RI[6:0] must contain valid data during a frame when the Slot 1 Valid or SCRA[1:0] are set.

### 5.3.3 Register Write Data (Slot 2)

Bit 19	18	17	16	15	14	13	12	11	10	9	8	7	6	5	4	3	2	1	0
WD15	WD14	WD13	WD12	WD11	WD10	WD9	WD8	WD7	WD6	WD5	WD4	WD3	WD2	WD1	WD0				

WD[15:0] Codec register data for write operations. For read operations, this data is ignored. If R/W# = 0, data must be valid in both the *Register Address* (Slot 1) and the *Register Write Data* (Slot 2) during a frame when the Slot [1:2] Valid = 11 or either SCRA[1:0] bit is set. Splitting the register address and the write data across multiple frames is not permitted.

### 5.3.4 Playback Data (Slots 3-11)

Bit 19	18	17	16	15	14	13	12	11	10	9	8	7	6	5	4	3	2	1	0
PD19	PD18	PD17	PD16	PD15	PD14	PD13	PD12	PD11	PD10	PD9	PD8	PD7	PD6	PD5	PD4	PD3	PD2	PD1	PD0

PD[19:0] 20-bit PCM playback (2's compliment) data for the left and right DACs, S/PDIF transmitter, or GPIO pins. Any PCM data from the Controller less than 20 bits should be left justified in the slot and zero-padded. Table 9 on page 35 lists the definition of each respective slot. The mapping of a given slot is determined by the MD[1:0] bits found in the *AC Mode Control* (Index 5Eh) register.

### 5.3.5 GPIO Data (Slot12)

Bit 19	18	17	16	15	14	13	12	11	10	9	8	7	6	5	4	3	2	1	0
						GP9	GP8	GP7	GP6	GP5	GP4	GP3	GP2	GP1	GP0				

GP[9:0] GPIO Output Data. Output data is transferred to the GPIO pins every frame in Slot 12.

## 5.4 AC-Link Audio Input Frame

In the serial data input frame, data is passed on the *SDATA\_IN* pin FROM the CS4298 to the AC '97 Controller. The data format for the input frame is very similar to the output frame. Figure 9 illustrates the serial port timing.

### 5.4.1 Serial Data Input Slot Tag Bits (Slot 0)

Bit 15	14	13	12	11	10	9	8	7	6	5	4	3	2	1	0
Codec Ready	Slot 1 Valid	Slot 2 Valid	Slot 3 Valid	Slot 4 Valid	Slot 5 Valid	Slot 6 Valid	Slot 7 Valid	Slot 8 Valid	Slot 9 Valid	Slot 10 Valid	Slot 11 Valid	Slot 12 Valid			

Codec Ready Indicates the readiness of the CS4298's AC-link and Control and Status registers. Immediately after a Cold Reset this bit will be clear. Once the CS4298's clocks and voltages are stable, this bit will be set. Until the Codec Ready bit is set, no AC-link transactions should be attempted by the Controller. The Codec Ready bit does not indicate readiness of the DACs, ADCs, Vref, or any other analog function. Those must be checked in the *Power Down Control/Status* (Index 26h), *Ext'd Audio Ctrl/Stat* (Index 2Ah), and *Ext'd Modem Ctrl/Stat* (Index 3Eh) registers by the Controller before any access is made to the mixer registers. Any accesses to the Codec while Codec Ready is clear is ignored.

Slot 1 Valid Tag

Indicates Slot 1 contains a valid read back address.

Slot 2 Valid Tag

Indicates Slot 2 contains valid register read data.

Slot [3:11] Valid Tag

Indicates Slot [3:11] contains valid capture data from the Codec's ADC.

Slot 12 Valid Tag

Indicates Slot 12 contains valid read data of the *GPIO Pin Status Register* (Index 54h).

#### 5.4.2 Read-Back Address Port (Slot 1)

Bit 19	18	17	16	15	14	13	12	11	10	9	8	7	6	5	4	3	2	1	0
	RI6	RI5	RI4	RI3	RI2	RI1	RI0												

RI[6:0] Register index. The Read-Back Address Port echoes the AC '97 Register address when a register read has been requested in the previous frame. The Codec will only echo the register index for a read access. Write accesses will not return valid data in Slot 1.

#### 5.4.3 Read-Back Data Port (Slot 2)

Bit 19	18	17	16	15	14	13	12	11	10	9	8	7	6	5	4	3	2	1	0
RD15	RD14	RD13	RD12	RD11	RD10	RD9	RD8	RD7	RD6	RD5	RD4	RD3	RD2	RD1	RD0				

RD[15:0] 16-bit register value. The Read-Back Data Port contains the register data requested by the Controller from the previous read request. All read requests will return the read address in the *Read-Back Address Port* (Slot 1) and the register data in the *Read-Back Data Port* (Slot 2) on the following serial data frame.

#### 5.4.4 PCM Capture Data (Slot 3-11)

Bit 19	18	17	16	15	14	13	12	11	10	9	8	7	6	5	4	3	2	1	0
CD17	CD16	CD15	CD14	CD13	CD12	CD11	CD10	CD9	CD8	CD7	CD6	CD5	CD4	CD3	CD2	CD1	CD0		

CD[17:0] 18-bit PCM (2's compliment) data. The mapping of a given slot to an ADC is determined by the state of the MD[1:0] bits found in the *AC Mode Control* (Index 5Eh) register.

#### 5.4.5 GPIO Pin Status (Slot 12)

Bit 19	18	17	16	15	14	13	12	11	10	9	8	7	6	5	4	3	2	1	0
						GI9	GI8	GI7	GI6	GI5	GI4	GI3	GI2	GI1	GI0				IRQ

GI[9:0] Status of the GPIO[9:0] pin.

IRQ Set when the GPIO generates a wake up or interrupt cycle. See *GPIO Pin Wake Up Mask* (Index 52h) register.

The capture data in Slot [3:12] will only be valid when the respective slot valid bit is set in Slot 0.

## 5.5 AC '97 Reset Modes

Three methods of resetting the CS4298, as defined in the AC '97 Specification, are supported: *Cold AC '97 Reset*, *Warm AC '97 Reset*, and *AC '97 Register Reset*. A Cold AC '97 Reset is required to restart the AC-link when bit PR5 is set in the *Power Down Control/Status* (Index 26h) register.

### 5.5.1 Cold AC '97 Reset

A Cold Reset is performed by asserting RESET# in accordance with the minimum timing specifications in the *Serial Port Timing* section. Once de-asserted, all of the Codec's registers will be reset to their default power-on states and the BIT\_CLK clock and SDATA\_IN signals will be reactivated. The timing of power-up/reset events is discussed in detail in the *Power Management* section.

### 5.5.2 Warm AC '97 Reset

The CS4298 may also be reactivated when the AC-link is powered down (refer to the PR4 bit description in the *Power Management* section) by a Warm Reset. A Warm Reset allows the AC-link to be reactivated without losing information in the Codec's registers. Warm Reset is initiated when the SYNC signal is driven high for at least 1  $\mu$ s and then driven low in the absence of the BIT\_CLK clock signal. The BIT\_CLK clock will not restart until at least 2 normal BIT\_CLK clock periods ( $\pm 162.8$  ns) after the SYNC signal is de-asserted.

### 5.5.3 AC '97 Register Reset

The third reset mode provides a register reset to the CS4298. This is available only when the CS4298's AC-link is active and the Codec Ready bit is set. The audio and modem subsections may be reset independently. Any write to *Reset* (Index 00h) register will reset the audio subsection while any write to *Ext'd Modem Ctrl/Stat* (Index 3Eh) register will reset the modem subsection. See the respective register descriptions for additional information.

## 5.6 AC-Link Protocol Violation - Loss of SYNC

The CS4298 is designed to handle SYNC protocol violations. The following are situations where the SYNC protocol has been violated:

- The SYNC signal is not sampled high for exactly 16 BIT\_CLK clock cycles at the start of an audio frame.
- The SYNC signal is not sampled high on the 256th BIT\_CLK clock period after the previous SYNC assertion.
- The SYNC signal goes active high before the 256th BIT\_CLK clock period after the previous SYNC assertion.

Upon loss of synchronization with the Controller, the Codec will mute all analog outputs and clear the Codec Ready bit in the serial data input frame until two valid frames are detected. During this detection period, the Codec will ignore all register reads and writes and will discontinue the transmission of PCM capture data.

## 6. REGISTER INTERFACE

Certain register locations change definition based on the basic operating mode (Mode 0-3) selected by the MD[1:0] bits found in the AC Mode Control (Index 5Eh) register. The reset default is Mode 0.

Reg Num	Name	D15	D14	D13	D12	D11	D10	D9	D8	D7	D6	D5	D4	D3	D2	D1	D0	Default
00h	Reset Mode 0		SE4	SE3	SE2	SE1		0	ID8	ID7			ID4	0	0	0	0	1990h
00h	Reset Mode 1		SE4	SE3	SE2	SE1		0	ID8	ID7			ID4	0	0	0	0	1990h
00h	Reset Mode 2		SE4	SE3	SE2	SE1		0	ID8	ID7			ID4	0	0	0	ID0	1991h
00h	Reset Mode 3		SE4	SE3	SE2	SE1		0	ID8	ID7			0	0	0	0	0	1980h
02h	Master Volume	Mute		ML5	ML4	ML3	ML2	ML1	ML0			MR5	MR4	MR3	MR2	MR1	MR0	8000h
04h	Alternate Line Out Volume	Mute		ML5	ML4	ML3	ML2	ML1	ML0			MR5	MR4	MR3	MR2	MR1	MR0	8000h
06h	Master Volume Mono	Mute											MM4	MM3	MM2	MM1	MM0	8000h
0Eh	Mic Volume	Mute									20dB		GN4	GN3	GN2	GN1	GN0	8008h
10h	Line In Volume	Mute			GL4	GL3	GL2	GL1	GL0				GR4	GR3	GR2	GR1	GR0	8808h
12h	CD Volume	Mute			GL4	GL3	GL2	GL1	GL0				GR4	GR3	GR2	GR1	GR0	8808h
14h	Video Volume	Mute			GL4	GL3	GL2	GL1	GL0				GR4	GR3	GR2	GR1	GR0	8808h
16h	Aux Volume	Mute			GL4	GL3	GL2	GL1	GL0				GR4	GR3	GR2	GR1	GR0	8808h
18h	PCM Out Vol	Mute			GL4	GL3	GL2	GL1	GL0				GR4	GR3	GR2	GR1	GR0	8808h
1Ah	Record Select						SL2	SL1	SL0						SR2	SR1	SR0	0000h
1Ch	Record Gain	Mute				GL3	GL2	GL1	GL0					GR3	GR2	GR1	GR0	8000h
1E	Record Gain Microphone	Mute												GR3	GR2	GR1	GR0	8000h
20h	General Purpose	POP		3D					MS	LPBK								0000h
22h	3D Control													S3	S2	S1	S0	0000h
26h	Powerdown Ctrl/Stat		PR6	PR5	PR4	PR3	PR2	PR1	PR0					REF	ANL	DAC	ADC	000Fh
28h	Ext'd Audio ID Mode 0	ID1	ID0															VRA x000h
28h	Ext'd Audio ID Mode 1	ID1	ID0															VRA x000h
28h	Ext'd Audio ID Mode 2	ID1	ID0															VRA x000h
28h	Ext'd Audio ID Mode 3	ID1	ID0						LDAC	SDAC	CDAC							VRA x1C0h
2Ah	Ext'd Audio Ctrl Mode 0																	0000h
2Ah	Ext'd Audio Ctrl Mode 1																	0000h
2Ah	Ext'd Audio Ctrl Mode 2		PRL						MADC									0200h
2Ah	Ext'd Audio Ctrl Mode 3			PRK	PRJ	PRI			LDAC	SDAC	CDAC							01C0h
2Ch	PCM Front DAC Rate	SR15	SR14	SR13	SR12	SR11	SR10	SR9	SR8	SR7	SR6	SR5	SR4	SR3	SR2	SR1	SR0	BB80h
2Eh	PCM Surround DAC Rate	SR15	SR14	SR13	SR12	SR11	SR10	SR9	SR8	SR7	SR6	SR5	SR4	SR3	SR2	SR1	SR0	BB80h
30h	PCM LFE DAC Rate	SR15	SR14	SR13	SR12	SR11	SR10	SR9	SR8	SR7	SR6	SR5	SR4	SR3	SR2	SR1	SR0	BB80h
32h	PCM Left/Right ADC Rate	SR15	SR14	SR13	SR12	SR11	SR10	SR9	SR8	SR7	SR6	SR5	SR4	SR3	SR2	SR1	SR0	BB80h
34h	MIC ADC Rate	SR15	SR14	SR13	SR12	SR11	SR10	SR9	SR8	SR7	SR6	SR5	SR4	SR3	SR2	SR1	SR0	BB80h
36h	Center LFE Volume	Mute		LFE5	LFE4	LFE3	LFE2	LFE1	LFE0	Mute		CNT5	CNT4	CNT3	CNT2	CNT1	CNT0	8080h
38h	LR Surround Volume	Mute		LSR5	LSR4	LSR3	LSR2	LSR1	LSR0	Mute		RSR5	RSR4	RSR3	RSR2	RSR1	RSR0	8080h
3Ch	Ext'd Modem ID Mode 0	ID1	ID0												HSET		LIN1	x005h
3Ch	Ext'd Modem ID Mode 1	ID1	ID0														LIN2	x003h
3Ch	Ext'd Modem ID Mode 2	ID1	ID0														LIN1	x001h
3C	Ext'd Modem ID Mode 3	ID1	ID0															x000h
3E	Ext'd Modem Stat/Ctrl Mode 0	PRH	PRG			PRD	PRC	PRB	PRA	HDAC	HADC			DAC1	ADC1	MREF	GPIO	00CFh
3E	Ext'd Modem Stat/Ctr Mode1			PRF	PRE	PRD	PRC	PRB	PRA			DAC2	ADC2	DAC1	ADC1	MREF	GPIO	003Fh
3E	Ext'd Modem Stat/Ctrl Mode 2	PRH				PRD	PRC	PRB	PRA	HDAC				DAC1	ADC1	MREF	GPIO	008Fh
3E	Ext'd Modem Stat/Ctrl Mode 3		PRG				PRC	PRB	PRA		HADC				ADC1	MREF	GPIO	0047h
40	Line 1 DAC/ADC Rate	SR15	SR14	SR13	SR12	SR11	SR10	SR9	SR8	SR7	SR6	SR5	SR4	SR3	SR2	SR1	SR0	BB80h
42	Line 2 DAC/ADC Rate	SR15	SR14	SR13	SR12	SR11	SR10	SR9	SR8	SR7	SR6	SR5	SR4	SR3	SR2	SR1	SR0	BB80h
44	Handset DAC/ADC Rate	SR15	SR14	SR13	SR12	SR11	SR10	SR9	SR8	SR7	SR6	SR5	SR4	SR3	SR2	SR1	SR0	BB80h
46	Line 1 DAC/ADC Level	Mute				DAC3	DAC2	DAC1	DAC0	Mute				ADC3	ADC2			8080h

**Table 1. Mixer Registers**

Reg Num	Name	D15	D14	D13	D12	D11	D10	D9	D8	D7	D6	D5	D4	D3	D2	D1	D0	Default
48	Line 2 DAC/ACD Level	Mute				DAC3	DAC2	DAC1	DAC0	Mute				ADC3	ADC2			8080h
4A	Handset DAC/ACD Level	Mute				DAC3	DAC2	DAC1	DAC0	Mute				ADC3	ADC2			8080h
4C	GPIO Pin Configuration							GC9	GC8	GC7	GC6	GC5	GC4	GC3	GC2	GC1	GC0	03FFh
4E	GPIO Pin Polarity/Type							GP9	GP8	GP7	GP6	GP5	GP4	GP3	GP2	GP1	GP0	FFFFh
50	GPIO Pin Sticky							GS9	GS8	GS7	GS6	GS5	GS4	GS3	GS2	GS1	GS0	0000h
52	GPIO Pin Walk-up Mask							GW9	GW8	GW7	GW6	GW5	GW4	GW3	GW2	GW1	GW0	0000h
54	GPIO Pin Status							GI9	GI8	GI7	GI6	GI5	GI4	GI3	GI2	GI1	GI0	xxxxh
56	Misc. Modem AFE Stat Mode 0						HSB2	HSB1	HSB0						L1B2	L1B1	L1B0	0000h
56	Misc. Modem AFE Stat Mode 1										L2B2	L2B1	L2B0		L1B2	L1B1	L1B0	0000h
56	Misc. Modem AFE Stat Mode 2														L1B2	L1B1	L1B0	0000h
56	Misc. Modem AFE Stat Mode 3																	0000h
<b>Cirrus Defined Registers:</b>																		
5A	Crystal Revision / Fab							1	1							1	0	0302h
5E	Slot Map Register						EDM	EAM	DDM							MD1	MD0	0000h
68	S/PDIF Enable	SPEN	V		Fs	L	CC6	CC5	CC4	CC3	CC2	CC1	CC0	Pre	Copy	#Audio	Pro	0000h
7Ch	Vendor ID1(CR)	F7	F6	F5	F4	F3	F4	F1	F0	S7	S6	S5	S4	S3	S2	S1	S0	4352h
7Eh	Vendor ID2(Y-)	T7	T6	T5	T4	T3	T2	T1	T0		PID2	PID1	PID0		RID2	RID1	RID0	5923h

**Table 1. Mixer Registers (cont.)**

## 6.1 Register Descriptions

### 6.1.1 Reset (Index 00h)

Mode	D15	D14	D13	D12	D11	D10	D9	D8	D7	D6	D5	D4	D3	D2	D1	D0
0		SE4	SE3	SE2	SE1	SE0	0	ID8	ID7	0	0	ID4	0	0	0	0
1		SE4	SE3	SE2	SE1	SE0	0	ID8	ID7	0	0	ID4	0	0	0	0
2		SE4	SE3	SE2	SE1	SE0	0	ID8	ID7	0	0	ID4	0	0	0	ID0
3		SE4	SE3	SE2	SE1	SE0	0	ID8	ID7	0	0	0	0	0	0	0

- SE[4:0]     3D Stereo Enhancement Technique.  
              00110 - Crystal 3D Stereo Enhancement.
- ID8 set     18-bit ADC resolution.
- ID7 set     20-bit DAC resolution.
- ID4 set     Headphone out support. (Alternate Line Output)
- ID1 set     Dedicated Mic PCM.

Read-only data Mode 0,1    1990h  
                   Mode 2     1991h  
                   Mode 3     1980h

Any write to this register causes the audio control registers (*Index 02h - 38h*) and the Crystal specific registers (*Index 5Eh - 68h*) to be reset forcing them to their default state. The mode control bits MD[1:0] of the *AC Mode Control (Index 5Eh)* register are also cleared forcing the Codec to Mode 0 configuration. Reads return configuration information about the audio Codec

### 6.1.2 Master Volume (Index 02h)

D15	D14	D13	D12	D11	D10	D9	D8	D7	D6	D5	D4	D3	D2	D1	D0
Mute		ML5	ML4	ML3	ML2	ML1	ML0			MR5	MR4	MR3	MR2	MR1	MR0

- Mute        Master mute for the LINE\_OUT\_L and the LINE\_OUT\_R output signals.
- ML[5:0]     Master Volume control for LINE\_OUT\_L pin. Least significant bit represents -1.5 dB with 00000 = 0 dB. The total range is 0 dB to -94.5 dB.
- MR[5:0]     Master Volume control for LINE\_OUT\_R pin. Least significant bit represents -1.5 dB with 00000 = 0 dB. The total range is 0 dB to -94.5 dB.
- Default     8000h, corresponding to 0 dB attenuation and mute on.

In Mode 3 the LINE\_OUT volume is controlled by the *Left Right Surround (Index 38h)* register in place of Master Volume.

### 6.1.3 Alternate Volume (Index 04h)

D15	D14	D13	D12	D11	D10	D9	D8	D7	D6	D5	D4	D3	D2	D1	D0
Mute		ML5	ML4	ML3	ML2	ML1	ML0			MR5	MR4	MR3	MR2	MR1	MR0

- Mute Master mute for the ALT\_LINE\_OUT\_L and the ALT\_LINE\_OUT\_R output signals.
- ML[5:0] Master Volume control for ALT\_LINE\_OUT\_L pin. Least significant bit represents -1.5 dB with 00000 = 0 dB. The total range is 0 dB to -94.5 dB.
- MR[5:0] Master Volume control for ALT\_LINE\_OUT\_R pin. Least significant bit represents -1.5 dB with 00000 = 0 dB. The total range is 0 dB to -94.5 dB.
- Default 8000h, corresponding to 0 dB attenuation and mute on.

In Mode 3 the ALT\_LINE\_OUT volume is controlled by the *LFE/CNT Volume (Index 36h)* register in place of Alternate Volume..

ML[5:0]/MR[5:0]/MM[5:0] Write	ML[5:0]/MR[5:0]/MM[5:0] Read	Gain Level
000000	000000	0 dB
000001	000001	-1.5 dB
...	...	...
111111	111111	-94.5 dB

**Table 2. Alternate Line-Out and Master Mono Attenuation**

### 6.1.4 Microphone Volume (Index 0Eh)

D15	D14	D13	D12	D11	D10	D9	D8	D7	D6	D5	D4	D3	D2	D1	D0
Mute									20dB		GN4	GN3	GN2	GN1	GN0

- Mute When set, mutes MIC1/MIC2 signal.
- GN[4:0] MIC1/MIC2 Volume Control. Least significant bit represents 1.5 dB with 01000 = 0 dB. The total range is 12 dB to -34.5 dB.
- 20dB Enables 20 dB microphone gain block.
- Default 8008h, 0 dB attenuation and Mute set.

This register controls the gain level of the Microphone input source to the Input Mixer. It also controls the +20 dB gain block which connects to the input volume control and to the Input Record Mux. The selection of MIC1 or MIC2 input pins is controlled by the MS bit in the *General Purpose (Index 20h)* register. The gain mapping for this register is shown in Table 3.

GN4 - GN0	Gain Level	Mic Gain with 20dB = 1
00000	+12.0 dB	+32.0 dB
00001	+10.5 dB	30.5 dB
...	...	...
00111	+1.5 dB	21.5 dB
01000	0.0 dB	20.0 dB
01001	-1.5 dB	18.5 dB
...	...	...
11111	-34.5 dB	-14.5 dB

**Table 3. Analog Mixer Input Gain Values**



### 6.1.5 Stereo Analog Mixer Input Gain (Index's 10h - 18h)

D15	D14	D13	D12	D11	D10	D9	D8	D7	D6	D5	D4	D3	D2	D1	D0
Mute			GL4	GL3	GL2	GL1	GL0				GR4	GR3	GR2	GR1	GR0

- Mute            When set mutes the respective input. Setting this bit mutes both right and left inputs.
- GL[4:0]       Left Volume Control. Least significant bit represents 1.5 dB with 01000 = 0 dB. The total range is 12 dB to -34.5 dB. See Table 3.
- GR[4:0]       Right Volume Control. Least significant bit represents 1.5 dB with 01000 = 0 dB. The total range is 12 dB to -34.5 dB. See Table 3.
- Default        8808h, 0 dB gain with Mute enabled.

These registers control the gain levels of the analog input sources to the Input Mixer. The analog inputs associated with registers 10h-18h are found in Table 4.

Register Index	Function
10h	Line IN Volume
12h	CD Volume
14h	Video Volume
16h	Aux Volume
18h	PCM Out Volume

**Table 4. Stereo Volume Register Index**

### 6.1.6 Input Mux Select (Index 1Ah)

D15	D14	D13	D12	D11	D10	D9	D8	D7	D6	D5	D4	D3	D2	D1	D0
					SL2	SL1	SL0						SR2	SR1	SR0

- SL[2:0]       Left Channel ADC input source select.
- SR[2:0]       Right Channel ADC input source select.
- Default       0000h, MIC inputs selected for both channels.

When capturing PCM data, this register controls the input MUX for the ADCs. Table 5 below lists the possible values for each input.

Sx2 - Sx0	Record Source
0	MIC
1	CD Input
2	Video Input
3	AUX Input
4	Line Input
5	Stereo Mix
6	Mono Mix
7	Not Available

**Table 5. Input Mux Selection**

### 6.1.7 Record Gain (Index 1Ch)

D15	D14	D13	D12	D11	D10	D9	D8	D7	D6	D5	D4	D3	D2	D1	D0
Mute				GL3	GL2	GL1	GL0					GR3	GR2	GR1	GR0

Mute When set, mutes the input to the ADCs.

GL[3:0] Left ADC gain. Least significant bit represents +1.5 dB with 0000 = 0 dB.  
The total range is 0 dB to +22.5 dB.

GR[3:0] Right ADC gain. Least significant bit represents +1.5 dB with 0000 = 0 dB.  
The total range is 0 dB to +22.5 dB.

Default 8000h, 0 dB gain with Mute on.

### 6.1.8 Record Gain Microphone (Index 1Eh)

D15	D14	D13	D12	D11	D10	D9	D8	D7	D6	D5	D4	D3	D2	D1	D0
Mute												GM3	GM2	GM1	GM0

Mute When set, mutes the input to MADC2.

GM[3:0] Dedicated Microphone gain. Least significant bit represents +1.5 dB with 0000 = 0 dB.  
The total range is 0 dB to +22.5 dB.

Default 8000h, 0 dB gain with Mute on.

This register is only available in Mode 2.

### 6.1.9 General Purpose (Index 20h)

D15	D14	D13	D12	D11	D10	D9	D8	D7	D6	D5	D4	D3	D2	D1	D0
POP		3D					MS	LPBK							

POP PCM Output Path. By default, the PCM output is mixed prior to the 3D enhancement. When set, the PCM output is mixed after the 3D enhancement.

3D 3D Enable. If set, enables the CrystalClear 3D stereo enhancement.

MS Microphone Select. Determines which of the two MIC inputs are passed to the mixer. When set, MIC2 input is selected; when clear MIC1 is selected.

LPBK Loopback. If set, enables Analog ADC/DAC Loopback Mode.

Default 0000h.

### 6.1.10 3D Control (Index 22h)

D15	D14	D13	D12	D11	D10	D9	D8	D7	D6	D5	D4	D3	D2	D1	D0
												S3	S2	S1	S0

S[3:0] Spacial Enhancement Depth. Spacial Enhancement is enabled by the 3D bit in the *General Purpose* (Index 20h) register.

0000 - No spacial enhancement.

1111 - Full spacial enhancement.

Default 0000h, no spacial enhancement added.

The Spacial Enhancements is not available on the ALT\_LINE output when the codec is in Mode 3 or EAM is set. See the *AC Mode Control (Index 5Eh)* register for more detail.

**6.1.11 Power Down Control/Status (Index 26h)**

D15	D14	D13	D12	D11	D10	D9	D8	D7	D6	D5	D4	D3	D2	D1	D0
	PR6	PR5	PR4	PR3	PR2	PR1	PR0					REF	ANL	DAC	ADC

- PR6      When set, the alternate line-out buffer is powered down.
- PR5      When set, the internal master clock is disabled. The only way to recover from setting this bit is through a cold AC '97 reset (driving the RESET# signal active).
- PR4      When set, the AC link is powered down. The AC link can be restarted through a warm AC '97 reset using the SYNC signal, or a cold AC '97 reset using the RESET# signal (the primary codec only).
- PR3      When set, the analog mixer and voltage reference are powered down. When clearing this bit, the ANL, ADC, and DAC bits should be checked before writing any mixer registers. Because the reference voltage is shared with the modem subsection, it will not power down unless the PRB bit is also set in the *Ext'd Modem Stat/Ctrl* (Index 3Eh) register.
- PR2      When set, the analog mixer is powered down (the voltage reference is still active). When clearing this bit, the ANL bit should be checked before writing any mixer registers.
- PR1      When set, the DACs are powered down. When clearing this bit, the DAC bit should be checked before sending any data to the DACs.
- PR0      When set, the ADCs and the ADC input muxes are powered down. When clearing this bit, no valid data will be sent down the AC link until the ADC bit goes high.
- REF      Voltage Reference Ready Status. When set, indicates the voltage reference is at a nominal level.
- ANL      Analog Ready Status. When set, the analog output mixer, input multiplexer, and volume controls are ready. When clear, no volume control registers should be written.
- DAC      DAC Ready Status. When set, the DACs are ready to receive data across the AC link. When clear, the DACs will not accept any valid data.
- ADC      ADC Ready Status. When set, the ADCs are ready to send data across the AC link. When clear, no data will be sent to the Controller.
- Default      0000h, all blocks are powered on. The lower four bits will eventually change as the Codec finishes an initialization and calibration sequence.

The PR[6:0] are power-down control for different sections of the Codec. The REF, ANL, DAC, and ADC bits are status bits which, when set, indicate that a particular section of the Codec is ready. After the Controller receives the Codec Ready bit in Slot 0, these status bits must be checked before writing to any mixer registers.

### 6.1.12 Extended Audio ID (Index 28h)

Mode	D15	D14	D13	D12	D11	D10	D9	D8	D7	D6	D5	D4	D3	D2	D1	D0
0	ID1	ID0														VRA
1	ID1	ID0														VRA
2	ID1	ID0														VRA
3	ID1	ID0						LDAC	SDAC	CDAC						VRA

ID[1:0] Codec configuration ID. Primary is 00; Secondary is 01,10,or 11. This is a reflection of the ID[1:0]# configuration pins. The state of the ID# pins are determined at power-up and are the inverse of the ID bits in this register.

LDAC PCM LFA DAC. Indicates a LFE DAC is supported.

SDAC PCM Surround DAC. Indicates a Surround DAC is supported.

CDAC PCM Center DAC. Indicates a Center DAC is supported.

VRA Variable Rate Audio. This bit is clear indicating variable sample rates are not supported.

Read-only data Mode 0,1,2 x000h. Where x is determined by the state of ID[1:0] input pins.  
 Mode 3 x1C0h.

### 6.1.13 Extended Audio Status / Control (Index 2Ah)

Mode	D15	D14	D13	D12	D11	D10	D9	D8	D7	D6	D5	D4	D3	D2	D1	D0
0		0	0	0	0	0	0	0	0	0						
1		0	0	0	0	0	0	0	0	0						
2		PRL	0	0	0	0	MDAC	0	0	0						
3		0	PRK	PRJ	PRI	0	0	LDAC	SDAC	CDAC						

CDAC PCM Center DAC Ready. When set, the Center DAC is ready.

LDAC PCM LFE DAC Ready. When set, the LFE DAC is ready.

SDAC PCM Surround DAC Ready. When set, the Surround DACs are ready.

MADC MIC ADC Ready. When Set, the dedicated Microphone ADC is ready.

PRI PCM Center DAC Disable. When set, the Center DAC is disabled.

PRJ PCM Surround DAC Disable. When set, the Surround DAC is disabled.

PRK PCM LFE DAC Disable. When set, the LFE DAC is disabled.

PRL Dedicated Microphone ADC Disable. When set, the MIC ADC is disabled.

Default Mode 0,1 0000h  
 Mode 2 0200h  
 Mode 3 01C0h

CDAC, LDAC, SDAC, and MADC are *read only* bits.

**6.1.14 PCM Front DAC Rate (Index 2Ch)**

D15	D14	D13	D12	D11	D10	D9	D8	D7	D6	D5	D4	D3	D2	D1	D0
SR15	SR14	SR13	SR12	SR11	SR10	SR9	SR8	SR7	SR6	SR5	SR4	SR3	SR2	SR1	SR0

SR[15:0] Front DAC Sample Rate.

Default Read-only value BB80h, indicating 48 kHz sample rate.

**6.1.15 PCM Surround DAC Rate (Index 2Eh)**

D15	D14	D13	D12	D11	D10	D9	D8	D7	D6	D5	D4	D3	D2	D1	D0
SR15	SR14	SR13	SR12	SR11	SR10	SR9	SR8	SR7	SR6	SR5	SR4	SR3	SR2	SR1	SR0

SR[15:0] Surround DAC Sample Rate.

Default Read-only value BB80h, indicating 48 kHz sample rate.

**6.1.16 PCM LFE DAC Rate (Index 30h)**

D15	D14	D13	D12	D11	D10	D9	D8	D7	D6	D5	D4	D3	D2	D1	D0
SR15	SR14	SR13	SR12	SR11	SR10	SR9	SR8	SR7	SR6	SR5	SR4	SR3	SR2	SR1	SR0

SR[15:0] LFE DAC Sample Rate.

Default Read-only value BB80h, indicating 48 kHz sample rate.

**6.1.17 PCM LR ADC Rate (Index 32h)**

D15	D14	D13	D12	D11	D10	D9	D8	D7	D6	D5	D4	D3	D2	D1	D0
SR15	SR14	SR13	SR12	SR11	SR10	SR9	SR8	SR7	SR6	SR5	SR4	SR3	SR2	SR1	SR0

SR[15:0] LR ADC Sample Rate.

Default Read-only value BB80h, indicating 48 kHz sample rate.

**6.1.18 PCM MIC ADC Rate (Index 34h)**

D15	D14	D13	D12	D11	D10	D9	D8	D7	D6	D5	D4	D3	D2	D1	D0
SR15	SR14	SR13	SR12	SR11	SR10	SR9	SR8	SR7	SR6	SR5	SR4	SR3	SR2	SR1	SR0

SR[15:0] MIC ADC Sample Rate.

Default Read-only value BB80h, indicating 48 kHz sample rate.

### 6.1.19 Center LFE Volume (Index 36h)

D15	D14	D13	D12	D11	D10	D9	D8	D7	D6	D5	D4	D3	D2	D1	D0
Mute		LFE5	LFE4	LFE3	LFE2	LFE1	LFE0	Mute		CNT5	CNT4	CNT3	CNT2	CNT1	CNT0

**LFE[5:0]** LFE Volume. Least significant bit represents -1.5 dB with 00000 = 0 dB. The total range is 0 dB to -94.5 dB.

**CNT[5:0]** Center Volume. Least significant bit represents -1.5 dB with 00000 = 0 dB. The total range is 0 dB to -94.5 dB.

**Default** 8080h, indicating mute with 0 dB attenuation.

<b>LFE[5:0]/LSR[5:0] CNT[5:0]/RSR[5:0] Write</b>	<b>LFE[5:0]/LSR[5:0] CNT[5:0]/RSR[5:0] Read</b>	<b>Gain Level</b>
000000	000000	0 dB
000001	000001	-1.5 dB
...	...	...
111111	111111	-94.5 dB

**Table 6. 6 Channel Volume Attenuation**

### 6.1.20 LR Surround Volume (Index 38h)

D15	D14	D13	D12	D11	D10	D9	D8	D7	D6	D5	D4	D3	D2	D1	D0
Mute		LSR5	LSR4	LSR3	LSR2	LSR1	LSR0	Mute		RSR5	RSR4	RSR3	RSR2	RSR1	RSR0

**LSR[5:0]** Left Surround Volume. Least significant bit represents -1.5 dB with 00000 = 0 dB. The total range is 0 dB to -94.5 dB.

**RSR[5:0]** Right Surround Volume. Least significant bit represents -1.5 dB with 00000 = 0 dB. The total range is 0 dB to -94.5 dB.

**Default** 8080h, indicating 0 dB attenuation.

### 6.1.21 Extended Modem ID (Index 3Ch)

Mode	D15	D14	D13	D12	D11	D10	D9	D8	D7	D6	D5	D4	D3	D2	D1	D0
0	ID1	ID0												HSET		LIN1
1	ID1	ID0													LIN2	
2	ID1	ID0														LIN1
3	ID1	ID0														

**HSET** Handset. Indicates handset ADC/DAC is supported.

**LIN1** Line 1. When set, indicates 1st line is supported.

**LIN2** Line 2. When set, indicates 2nd line is supported.

**ID[1:0]** Codec configuration ID. Primary is 00; Secondary is 01, 10, or 11. This is a reflection of the configuration pins. The state of the ID# pins are determined at power-up and are the inverse of the ID bits in this register.

**Default** Mode 0 x005h  
 Mode 1 x003h  
 Mode 2 x001h  
 Mode 3 x000h Where x is determined by the state of ID[1:0] input pins.

The Extended Modem ID is a *read/write* register that identifies the Codec's modem capabilities. This register reports the features available based on the basic operating mode determined by MD[1:0] of AC Mode (Index 5Eh) register. Writing any value to this location issues a reset to the modem registers (Index 3Ch-56h). Audio registers are not reset by a write to this location.

**NOTE:** All GPIO registers (Index 46h-54h) are reset by any write to this location.

### 6.1.22 Extended Modem ID (Index 3Eh)

Mode	D15	D14	D13	D12	D11	D10	D9	D8	D7	D6	D5	D4	D3	D2	D1	D0
0	PRH	PRG			PRD	PRC	PRB	PRA	HDAC	HADC			DAC1	ADC1	MREF	GPIO
1			PRF	PRE	PRD	PRC	PRB	PRA			DAC2	ADC2	DAC1	ADC1	MREF	GPIO
2	PRH				PRD	PRC	PRB	PRA	HDAC				DAC1	ADC1	MREF	GPIO
3		PRG				PRC	PRB	PRA		HADC				ADC1	MREF	GPIO

- PRH Handset DAC. When set powers down the Handset DAC.
- PRG Handset ADC. When set powers down the Handset ADC.
- PRF Line 2 DAC. When set powers down the Line 2 DAC.
- PRE Line 2 ADC. When set powers down the Line 2 ADC.
- PRD Line 1 DAC. When set powers down the Line 1 DAC.
- PRC Line 1 ADC. When set powers down the Line 1 ADC.
- PRB Modem Reference. When set powers down the modem reference. The modem and audio share a common reference. The reference will not power down unless PR3 of the *Power Down Ctrl/Stat (Index 26h)* register is also set.
- PRA GPIO. When set the GPIO pins are tri-state and powered down. Slot 12 is marked invalid if the AC-link is active.
- HDAC Handset DAC. When set indicates the Handset DAC is ready.
- HADC Handset ADC. When set indicates the Handset ADC is ready.
- DAC2 Line 2 DAC. When set indicates the Line 2 DAC is ready.
- ADC2 Line 2 ADC. When set indicates the Line 2 ADC is ready.
- DAC1 Line 1 DAC. When set indicates the Line 1 DAC is ready.
- ADC1 Line 1 ADC. When set indicates the Line 1 ADC is ready.
- MREF Modem Reference. When set indicates the modem reference is ready.
- GPIO GPIO. When set the GPIO pins are ready. Slot 12 is marked valid.

Default Mode 0 x0CFh  
 Mode 1 x03Fh  
 Mode 2 x08Fh  
 Mode 3 x047h Where x is determined by the state of ID[1:0] input pins.

PR[A:H] are *read/write* bits that provide power management of the modem AFE subsection. All remaining bits are *read/only* status indicating modem subsystems are ready for operation. After reset or issuing a change to the MD[1:0] of AC Mode (*Index 5Eh*) register, the respective status bits for that mode will be clear until the subsystem becomes ready.

### 6.1.23 Line 1 DAC/ADC Rate (Index 40h)

D15	D14	D13	D12	D11	D10	D9	D8	D7	D6	D5	D4	D3	D2	D1	D0
SR15	SR14	SR13	SR12	SR11	SR10	SR9	SR8	SR7	SR6	SR5	SR4	SR3	SR2	SR1	SR0

SR[15:0] Line 1 DAC/ADC Sample Rate.  
 Default Read-only value BB80h, indicating 48 kHz sample rate.

### 6.1.24 Line 2 DAC/ADC Rate (Index 42h)

D15	D14	D13	D12	D11	D10	D9	D8	D7	D6	D5	D4	D3	D2	D1	D0
SR15	SR14	SR13	SR12	SR11	SR10	SR9	SR8	SR7	SR6	SR5	SR4	SR3	SR2	SR1	SR0

SR[15:0] Line 2 DAC/ADC Sample Rate.  
 Default Read-only value BB80h, indicating 48 kHz sample rate.

**6.1.25 Handset DAC/ADC Rate (Index 44h)**

D15	D14	D13	D12	D11	D10	D9	D8	D7	D6	D5	D4	D3	D2	D1	D0
SR15	SR14	SR13	SR12	SR11	SR10	SR9	SR8	SR7	SR6	SR5	SR4	SR3	SR2	SR1	SR0

SR[15:0] Handset DAC/ADC Sample Rate.

Default Read-only value BB80h, indicating 48 kHz sample rate.

**6.1.26 Line 1 DAC/ADC Level (Index 46h)**

D15	D14	D13	D12	D11	D10	D9	D8	D7	D6	D5	D4	D3	D2	D1	D0
Mute				DAC3	DAC2	DAC1	DAC0	Mute				ADC3	ADC2		

Mute[D15] Mute. Mutes the input of Line 1 DAC.

Mute[D7] Mute. Mutes the output of Line 1 ADC.

DAC[3:0] Line 1 DAC attenuation. Least significant bit represents 1.5 dB with 00000 = 0 dB. The total range is 0 dB to -22.5 dB.

ADC[3:2] Line 1 ADC gain. Least significant bit represents 6 dB with 00 = 0 dB. The total range is 0 dB to +18 dB.

Default 8080h indicating mute with 0 dB attenuation or gain.

When EAM of the *AC Mode Control (Index 5Eh)* is set, the Line 1 DAC attenuation is controlled by ML[4:0] of the *Alternate Volume (Index 04h)* register.

**6.1.27 Line 2 DAC/ADC Level (Index 48h)**

D15	D14	D13	D12	D11	D10	D9	D8	D7	D6	D5	D4	D3	D2	D1	D0
Mute				DAC3	DAC2	DAC1	DAC0	Mute				ADC3	ADC2		

Mute[D15] Mute. Mutes the input of Line 2 DAC.

Mute[D7] Mute. Mutes the output of Line 2 ADC.

DAC[3:0] Line 2 DAC attenuation. Least significant bit represents 1.5 dB with 00000 = 0 dB. The total range is 0 dB to -22.5 dB.

ADC[3:2] Line 2 ADC gain. Least significant bit represents 6 dB with 00 = 0 dB. The total range is 0 dB to +18 dB.

Default 8080h indicating mute with 0 dB attenuation or gain.

When EAM of the *AC Mode Control (Index 5Eh)* is set, the Line 2 DAC attenuation is controlled by MR[4:0] of the *Alternate Volume (Index 04h)* register.

**6.1.28 Handset DAC/ADC Level (Index 4Ah)**

D15	D14	D13	D12	D11	D10	D9	D8	D7	D6	D5	D4	D3	D2	D1	D0
Mute				DAC3	DAC2	DAC1	DAC0	Mute				ADC3	ADC2		

Mute[D15] Mute. Mutes the input of Handset DAC.

Mute[D7] Mute. Mutes the output of Handset ADC.

DAC[3:0] Handset1 DAC attenuation. Least significant bit represents 1.5 dB with 00000 = 0 dB. The total range is 0 dB to -22 dB.

ADC[3:2] Handset ADC gain. Least significant bit represents 6 dB with 00 = 0 dB. The total range is 0 dB to +18 dB.

Default 8080h indicating mute with 0 dB attenuation or gain.



**6.1.29 GPIO Pin Configuration (Index 4Ch)**

D15	D14	D13	D12	D11	D10	D9	D8	D7	D6	D5	D4	D3	D2	D1	D0
0	0	0	0	0	0	GC9	GC8	GC7	GC6	GC5	GC4	GC3	GC2	GC1	GC0

GC[9:0] GPIO Pin Configuration. When set defines the corresponding GPIO pin as an input

Default 03FFh

After a cold reset, power up, or modem register reset (see Extended Modem ID (*Index 3Ch*)) all GPIO pins are configured as inputs.

**6.1.30 GPIO Pin Polarity/Type Configuration (Index 4Eh)**

D15	D14	D13	D12	D11	D10	D9	D8	D7	D6	D5	D4	D3	D2	D1	D0
1	1	1	1	1	1	GP9	GP8	GP7	GP6	GP5	GP4	GP3	GP2	GP1	GP0

GP[9:0] GPIO Pin Configuration. The definition of GP[9:0] changes based on the pin defined as an input or an output by GC[9:0] of *GPIO Pin Configuration (Index 4Ch)*.

Default FFFFh

When the GPIO pin is defined as an input, its status is reported in the GPIO Pin Status (*Index 54h*) register as well as Slot 12.

GCx	GPx	Function	
0	0	Output	CMOS drive
0	1	Output	Open drain
1	0	Input	Active Low
1	1	Input	Active High (default)

**Table 7. GPIO Input/Output Configuration**

**6.1.31 GPIO Pin Sticky (Index 50h)**

D15	D14	D13	D12	D11	D10	D9	D8	D7	D6	D5	D4	D3	D2	D1	D0
						GS9	GS8	GS7	GS6	GS5	GS4	GS3	GS2	GS1	GS0

GS[9:0] GPIO Pin Sticky. If set, the GPIO pin input is latched.

Default 0000h

If a GPIO is defined as “sticky” the input requires a transition of the GPIO input pin to set the corresponding bit in Slot 12 and the *GPIO Pin Status (Index 54h)* register. When “sticky” is set the corresponding bit in *GPIO Pin Polarity/Type Configuration (Index 4Ah)* register determines which edge of the GPIO pin will set GI[x]. If GP[x] is set, a low to high transition sets the GI[x] bit. A high to low transition sets GI[x] if GP[x] is clear. Once set, writing a 0 to GI[x] will clear the “sticky” input.

**6.1.32 GPIO Pin Wakeup Mask (Index 4Ch)**

D15	D14	D13	D12	D11	D10	D9	D8	D7	D6	D5	D4	D3	D2	D1	D0
						GW9	GW8	GW7	GW6	GW5	GW4	GW3	GW2	GW1	GW0

GS[9:0] Wake up mask. If set, allow the GPIO input to generate AC-LINK wake up protocol.  
 Default 0000h

The CS4298 has the ability to generate a “wake up” cycle by a transition of a GPIO pin when the AC-Link has been powered down. If a mask bit is set, a one being set in the corresponding GPIO Pin Status (Index 54h) will initiate a wake up interrupt. Bit 0 of SDATA\_IN Slot 12 will be set indicating a GPIO interrupt. GPIO pins must be defined as “input”, “sticky”, and the mask set to allow a GPIO interrupt. The GPIO interrupt is cleared by writing a 0 to the respective status bit in *GPIO Pin Status (Index 54h)* register.

**6.1.33 GPIO Pin Status (Index 54h)**

D15	D14	D13	D12	D11	D10	D9	D8	D7	D6	D5	D4	D3	D2	D1	D0
						GI9	GI8	GI7	GI6	GI5	GI4	GI3	GI2	GI1	GI0

GI[9:0] GPIO pin status. Reflects the state of all GPIO pins either input or output. If the GPIO pin is defined as an output, the respective bit reflects the state of SDATA\_OUT Slot 12. If the GPIO pin is defined as an input, the register is reflected in SDATA\_IN Slot 12. GPIO output pins cannot be accessed by Slot 1,2 register access, only by SDATA\_OUT Slot 12.

**6.1.34 Misc. Modem AFE Status (Index 56h)**

Mode	D15	D14	D13	D12	D11	D10	D9	D8	D7	D6	D5	D4	D3	D2	D1	D0
0						HSB2	HSB1	HSB0						L1B2	L1B1	L1B0
1										L2B2	L2B1	L2B0		L1B2	L1B1	L1B0
2														L1B2	L1B1	L1B0
3																

HSB[2:0] Handset Loopback.  
 L2B[2:0] Line 2 Loopback.  
 L1B[2:0] Line 1 Loopback.

Default 0000h.

Loop Back Mode HSB[2:0], L2B[2:0], L1B[2:0]	Function
000	Disabled
001	Digital Loop Back
010	Local Analog Loop Back
011	DAC to ADC 1-Bit data Loop Back
100	Remote Analog Loop Back
101	AC-Link Loop Back
110-111	Not Used

**Table 8. Misc. Modem Configuration**

**6.1.35 AC Mode Control (Index 5Eh)**

D15	D14	D13	D12	D11	D10	D9	D8	D7	D6	D5	D4	D3	D2	D1	D0
					EDM	EAM	DDM							MD1	MD0

**DDM** DAC Direct Mode. This bit controls the source to the line and alternate line output drivers. When set, the Left and Right DAC directly drive the line and alternate line outputs by bypassing the audio mixer. When clear, the audio mixer is the source for the line and alternate line outputs.

**EAM** Extended Audio Mode. When set the output of MDAC2 and MDAC1 are mapped to the ALT\_LINE OUTPUT. The MDAC volumes are set by the *Alternate Line Volume (Index 04h)* register when in this mode.

**EDM** Extended Docking Mode. When set the output of the analog input mixer is routed to the MADC1 and MADC2 inputs. This allows any analog input mix to be digitized and routed to a second AC '97 codec or allows the host controller to add effects processing to analog sources.

**MD[1:0]** Mode. Sets basic operating mode for the codec. This effects the mapping of the ADCs and DACs to AC-LINK Slot locations. See the Mode of Operation subsection for additional detail. Table XXX below details the Slot mapping.

**Default** 0000h

Mode	Definition	Audio DAC1	Audio DAC2	Audio ADC1	Audio ADC2	Modem DAC1	Modem DAC2	Modem ADC1	Modem ADC2	GPIO
0	Basic	Left	Right	Left	Right	Line 1	Handset	Line 1	Handset	
		3	4	3	4	5	11	5	11	12
1	2 Line	Left	Right	Left	Right	Line 1	Line 2	Line 1	Line 2	
		3	4	3	4	5	10	5	10	12
2	Speakerphone	Left	Right	Left	Right	Line 1	Handset	Line 1	Mic	
		3	4	3	4	5	11	5	6	12
3	Extended 4 Channel	Surrnd Left	Surrnd Right	Left	Right	Center	LFE	Line 1	Handset	
		7	8	3	4	6	9	5	11	12

**Table 9. Slot Assignments**
**6.1.36 S/PDIF Control (Index 68h)**

D15	D14	D13	D12	D11	D10	D9	D8	D7	D6	D5	D4	D3	D2	D1	D0
SPEN	V	0	0	L	CC6	CC5	CC4	CC3	CC2	CC1	CC0	Pre	Copy	#Audio	0

**SPEN** S/PDIF Enable. When set, Slot 6 and Slot 9 are mapped to the SPDIF\_OUT pin. When in Mode 3 and SPEN set, data is not passed to Modem DAC1 and Modem DAC2.

**V** Validity Bit. When set, this bit notifies the S/PDIF receiver that the subframe data is not suitable for conversion.

**L** Generation Level.

**CC[6:0]** Category Code.

**Pre** Premphasis. If set, filter premphasis is 50/15  $\mu$ s. If clear, premphasis is none.

**Copy** Copyright. When clear, copyright is asserted. If clear, copyright is not asserted.

**#Audio** #Audio valid. When clear, the data routed to the S/PDIF transmitter contains valid PCM data. For transmitting all other compressed data formats, the #Audio bit must be set.

**Default** 0000h.

**6.1.37 Vendor ID1 (Index 7Ch)**

D15	D14	D13	D12	D11	D10	D9	D8	D7	D6	D5	D4	D3	D2	D1	D0
F7	F6	F5	F4	F3	F2	F1	F0	S7	S6	S5	S4	S3	S2	S1	S0

F[7:0] First Character of Vendor ID.  
43h - ASCII 'C' character.

S[7:0] Second Character of Vendor ID.  
52h - ASCII 'R' character.

Read-only data4352h.

**6.1.38 Vendor ID2 (Index 7Eh)**

D15	D14	D13	D12	D11	D10	D9	D8	D7	D6	D5	D4	D3	D2	D1	D0
T7	T6	T5	T4	T3	T2	T1	T0		PID2	PID1	PID0		RID2	RID1	RID0

T[7:0] Third Character of Vendor ID.  
59h - ASCII 'Y' character.

PID[3:0] Part ID.  
See Table10 below.

RID[2:0] Revision.  
See Table10 below.

Read-only data5923h.

The two Vendor ID registers provide a means to determine the manufacturer of the AC '97 Codec. The first three bytes of the ID registers contain the ASCII code for the first 3 letters of Crystal (CRY). The final byte of the Vendor ID2 register is divided into a Part ID field and a Revision field. Table 10 lists the Part ID's defined to date.

PID3-PID0	Part Name
000	CS4297
001	CS4297A
010	CS4294 Rev C *
010	CS4298
011	CS4299
	* D3 set

**Table 10. Reg. 7Eh Defined Part ID's**

**7. ANALOG HARDWARE DESCRIPTION**

The analog hardware consist of a four line-level stereo inputs, two selectable mono microphone inputs, two mono inputs, a mono output, and dual, independent stereo line outputs. This section describes the analog hardware needed to interface with these pins.

**7.1 Line-Level Inputs**

The analog inputs consist of four stereo analog inputs and four mono inputs. As shown in Figure 8, the input to the ADCs comes from the Input Mux which selects one of the following: Phone (Mono), Aux, Video, CD, Mic1 or Mic2 (Mono), Line, Stereo Output Mix, or the Mono Output Mix (Mono). Unused analog inputs should be connected together and then connected through a capacitor to analog ground or tied to the Vrefout line directly.

The analog input mixer is designed to accommodate five stereo inputs and one mono input. These inputs are: a stereo line-level input (LINE), a mono microphone input (MIC), a stereo CD-ROM input (CD), a stereo auxiliary line-level input (AUX), and the PCM output from the DACs. Each of the stereo inputs has separate volume controls for each channel and one mute control for each left/right pair. The mono microphone input has one mute and one volume control.

The inputs to the output mixer are: the input mixer output, the PC Beep mono input, and the Phone mono input.

All analog inputs to the CS4298, including CD\_GND, should be capacitively coupled to the input pins.

Since many analog levels can be as large as 2 V<sub>RMS</sub>, the circuit shown in Figure 10 can be used to attenuate the analog input by 6 dB (to 1 V<sub>RMS</sub>) which is the maximum voltage allowed for all the stereo line-level inputs: LINE\_IN, AUX\_IN, and VIDEO\_IN.

The CD line-level inputs have an extra pin, CD\_GND, which provides a pseudo-differential input for both CD\_L and CD\_R. This pin takes the common-mode noise out of the CD inputs when connected to the ground coming from the CD analog source. Connecting the CD pins as shown in Figure 11 provides extra attenuation of common mode noise coming from the CDROM drive, thereby producing a higher quality signal. One percent resistors are recommended since the better the resistors match, the better the common-mode attenuation of unwanted signals. If CD is not used, the inputs should be connected through AC capacitors to analog ground or connected to Vrefout.

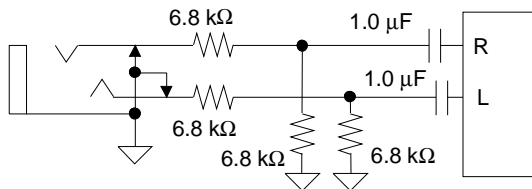

**Figure 10. Line Inputs**

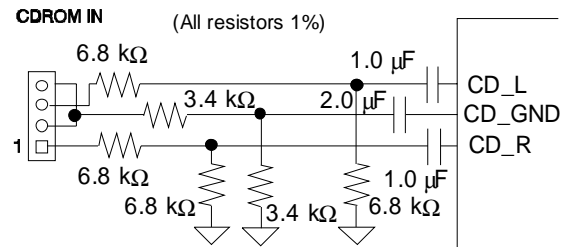

**Figure 11. Differential CDROM In**

**7.2 Microphone Level Inputs**

The microphone level inputs, MIC1 and MIC2, include a selectable -34.5 dB to +12 dB gain stage for interfacing to an external microphone. An additional 20 dB gain block is also available. Figure 12 illustrates a single-ended microphone input buffer circuit that will support lower gain mics. The circuit in Figure 12 supports dynamic mics and phantom-powered mics that use the right channel (ring) of the jack for power..

**7.3 Line Level Outputs**

The analog output section provides a stereo line-level output and an alternate stereo line-level output. LINE\_OUT\_L, LINE\_OUT\_R, ALT\_LINE\_OUT\_L, and ALT\_LINE\_OUT\_R outputs should be capacitively coupled to external circuitry.

The mono output, MONO\_OUT, can be used as either a sum of the left and right output channels attenuated by 6 dB to prevent clipping at full scale or the selected MIC\_IN signal. The mono out channel can be used to drive the PC internal mono speaker using an appropriate drive circuit. This approach allows the traditional PC sounds to be integrated with the rest of the audio system. The mute control is independent of the line outputs allowing the mono channel to mute the speaker without muting the line outputs.

Each of the 5 analog outputs, if used in the design, require 680 pF or larger NPO dielectric capacitors between the corresponding pin and AGND. Each analog output is DC biased up to the Vrefout voltage signal reference which is nominally 2.2 V. This requires that the output either be AC coupled to external circuitry (AC load must be greater than 10 kΩ) or DC coupled to a buffer op-amp biased at the Vrefout voltage (see Figure 13 for the recommended headphone op-amp circuit).

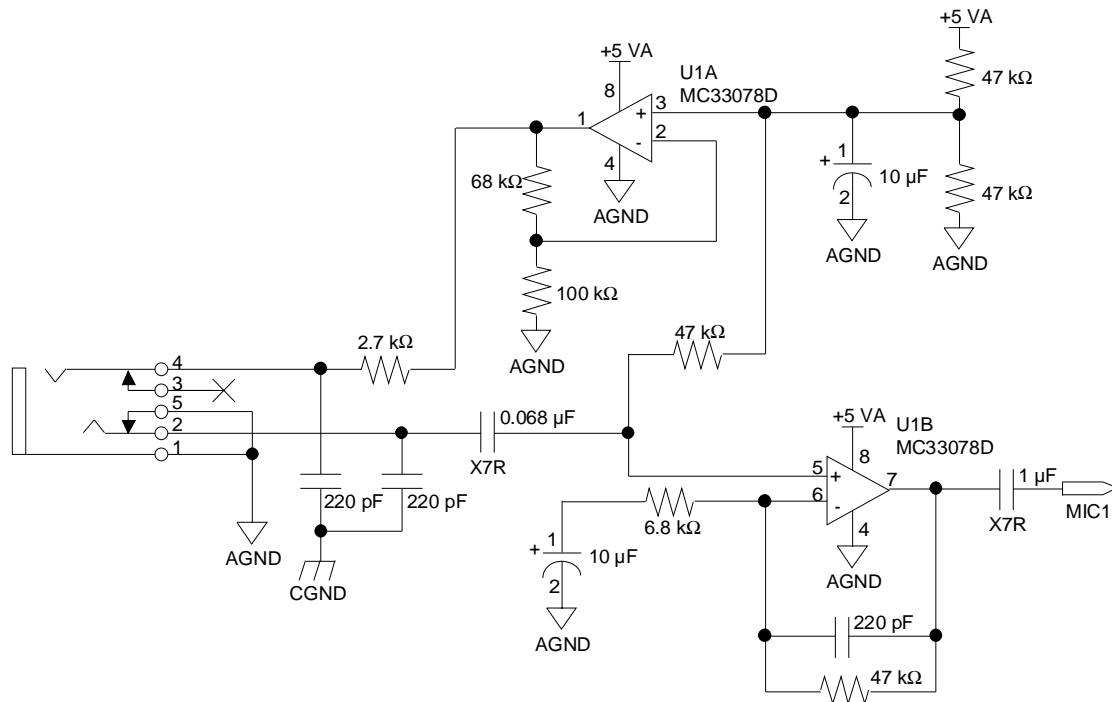

**Figure 12. PC '99 Microphone Pre-amplifier**

**7.4 Consumer IEC-958 Digital Interface (S/PDIF)**

The CS4298 supports the industry standard IEC-958 consumer digital interface. Sometimes this standard is referred to as S/PDIF, which refers to an older version of this standard. This output provides an interface, external to the PC, for storing digital CD-ROM) or playing digital audio from digital speakers. Figure 14 illustrates the circuit necessary for implementation of the IEC-958 consumer interface. The CS4298 is capable of directly driving the voltage divider for the 75 Ω interface. An optional current driver is shown when an increase of the transmission range of the coaxial circuitry is required. An optional fiber optic circuit may be connected directly to the CS4298.

**7.5 Miscellaneous Analog Signals**

The AFILT1 and AFILT2 pins must have a 1000 pF NPO capacitor (must not be smaller than 390 pF) to analog ground. These capacitors, along with an internal resistor, provide a single-pole low-pass filter at the inputs to the ADCs. By placing these filters at the input to the ADCs, low-pass filters at each analog input pin are not necessary.

The REFFLT pin lowers the noise of the internal voltage reference. A 1 μF (must not be greater than 1 μF) and 0.1 μF capacitor to analog ground should be connected with a short, wide trace to this pin. No other connection should be made, as any coupling onto this pin will degrade the analog performance of the Codec. Likewise, digital signals should be kept away from REFFLT for similar reasons.

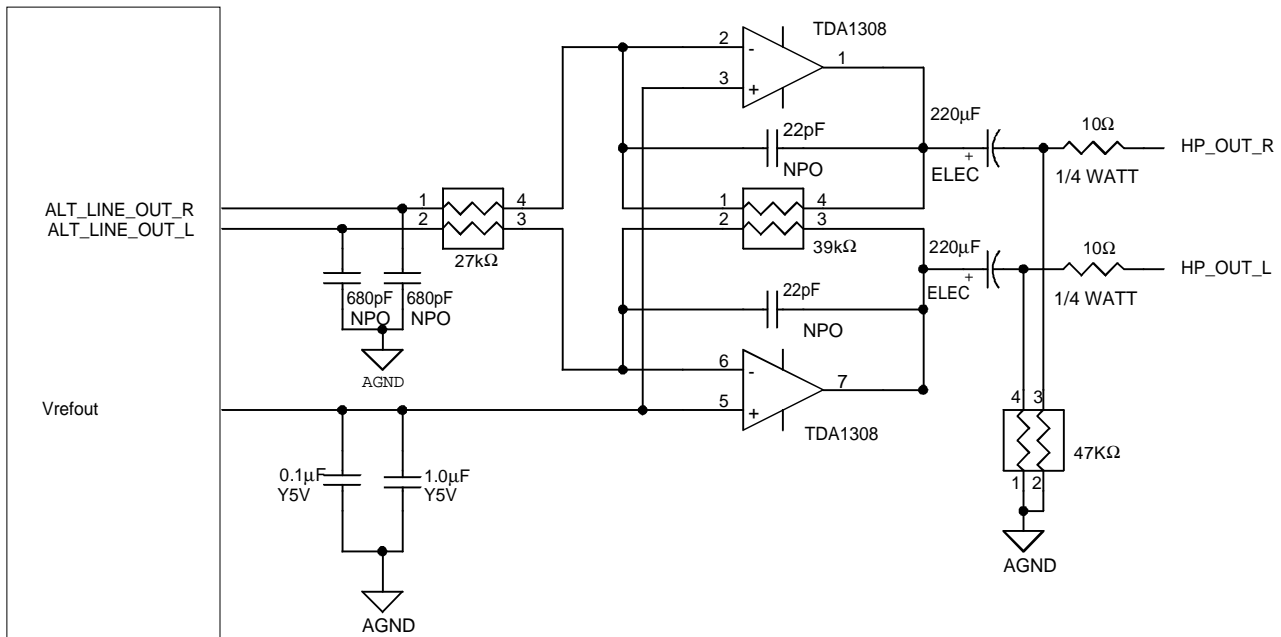

**Figure 13. Headphones Driver**

The Vrefout pin is typically 2.2 V and provides a common mode signal for single-supply external circuits. Vrefout only supports light DC loads and should be buffered if AC loading is needed. For typical use, a 0.1  $\mu\text{F}$  in parallel with a 1  $\mu\text{F}$  capacitor should be connected to Vrefout.

**7.6 Power Supplies**

The power supplies providing analog power should be as clean as possible to minimize coupling into the analog section which could degrade analog performance. The pins AVdd1 and AVdd2 supply power to all the analog circuitry on the CS4298. This 5 Volt analog supply should be generated from a voltage regulator (7805 type) connected to a +12 Volt supply. This helps isolate the analog circuitry from noise typically found on +5 V digital supplies which power many digital circuits in a PC environment. A typical voltage regulator circuit for analog power using an MC78M05CDT is shown in Figure 15.

The digital power pins DVdd1 and DVdd2 should be connected to the same digital supply as the AC '97 Controller's AC-Link interface. Since the digital interface on the CS4298 may operate at either 3.3 V or 5 V, proper connection of these pins will depend on the digital power supply of the AC '97 Controller. connections (vias). The AC-Link digital interface connection traces should be routed

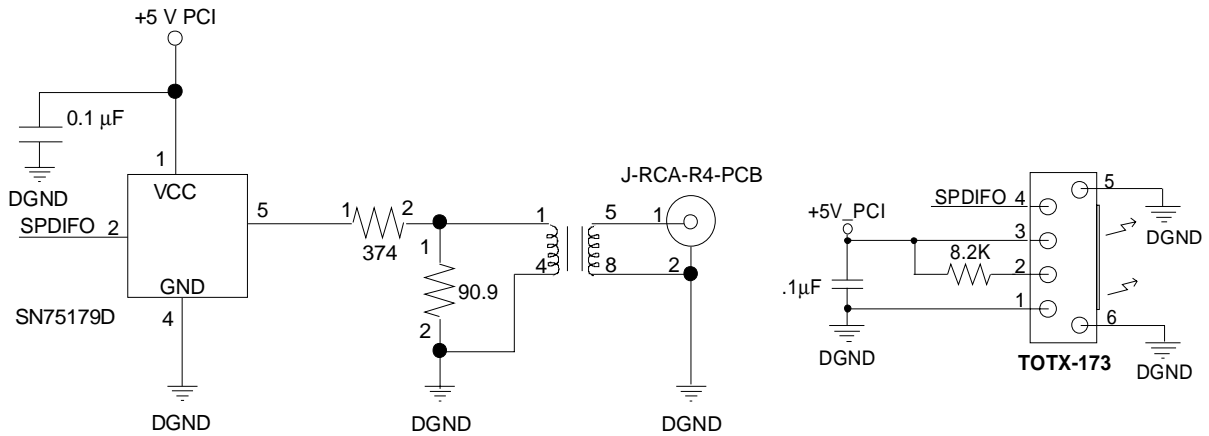

**Figure 14. IEC-958 Interface Examples**

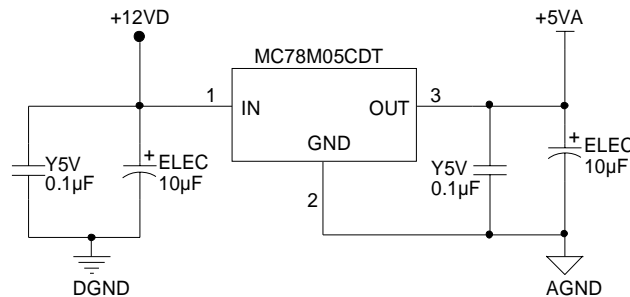

**Figure 15. Voltage Regulator**



such that digital ground plane lies underneath these signals (on the internal ground layer) from the AC '97 Controller continuously to the CS4298.

**7.7 Hybrid Interface**

Figure 16 indicates the required components for the secondary side of the hybrid circuitry required for the CS4298. The multiple configurations required for the line interface are beyond the scope of this document. Please contact Crystal applications engineering for additional information.

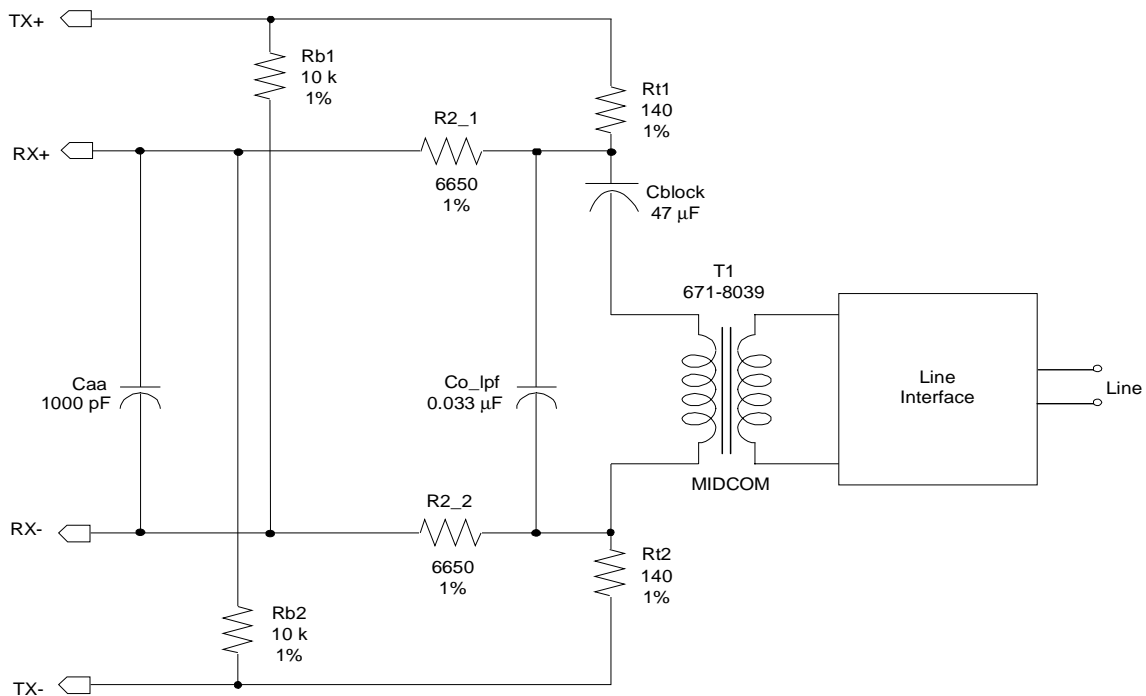

**Figure 16. Hybrid Circuit Secondary**

**Schematic & Layout Review Service**

Confirm Optimum  
Schematic & Layout  
Before Building Your Board.

For Our Free Review Service  
Call Applications Engineering.

C a l l : ( 5 1 2 ) 4 4 5 - 7 2 2 2

**8. PIN DESCRIPTIONS**

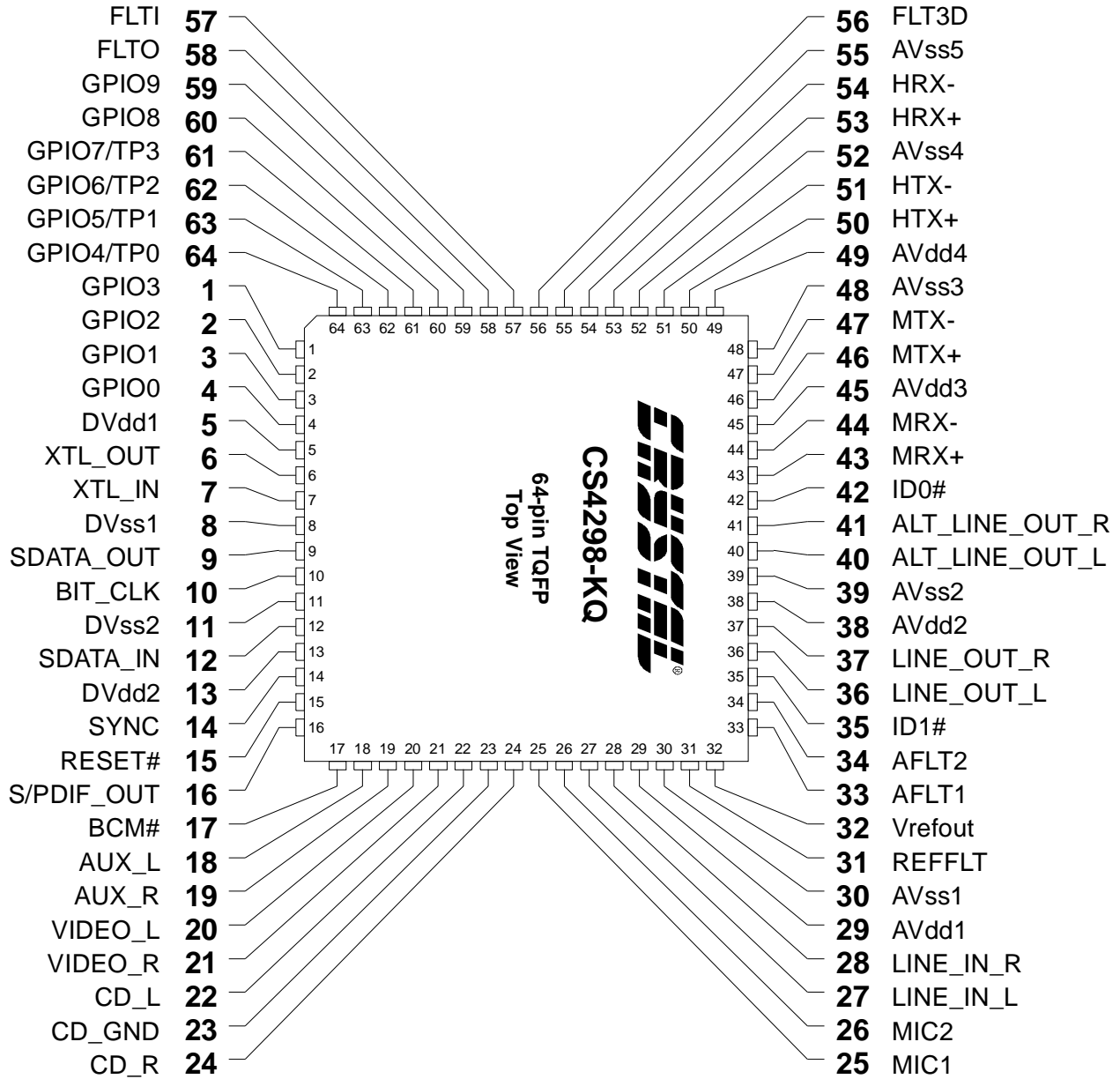

8.1 g2

## Digital I/O Pins

**RESET# - AC '97 Chip Reset, Input**

This active low signal is the asynchronous Cold Reset input to the CS4298. The CS4298 must be reset before it can enter normal operating mode. When the PR4 bit of register 26h is set, the RESET# rising edge will be used as an AC '97 2.1 Warm Reset only, preserving register values.

**SYNC - AC-link Serial Port Sync pulse, Input**

This signal is the serial port timing signal for the AC-link of the CS4298. Its period is the reciprocal of the sample rate of the CS4298, 48 kHz. This signal is generated by the AC '97 Controller and is synchronous to BIT\_CLK. SYNC is also an asynchronous input when the CS4298 is in a PR4 powerdown state and is configured as a primary codec. A series terminating resistor of 47  $\Omega$  should be connected on this signal close to the device driving the signal.

**BIT\_CLK - AC-link Serial Port Master Clock, Input/Output**

This input/output signal controls the master clock timing for the AC-link. In codec primary mode, this signal is an output 12.288 MHz clock signal which is divided down by two from the XTL\_IN input clock pin. In codec secondary mode, this signal is an input which controls the AC-link serial interface. In BIT\_CLK mode, this signal generates all internal clocking including the AC-link serial interface timing. A series terminating resistor of 47  $\Omega$  should be connected on this signal close to the CS4298 in primary mode or close to the BIT\_CLK source if in secondary mode.

**SDATA\_OUT - AC-link Serial Data Input Stream to AC '97, Input**

This input signal transmits the control information and digital audio output streams to be sent to the DACs. The data is clocked into the CS4298 on the falling edge of BIT\_CLK. A series terminating resistor of 47  $\Omega$  should be connected on this signal close to the device driving the input.

**SDATA\_IN - AC-link Serial Data Output Stream from AC '97, Output**

This output signal transmits the status information and digital audio input streams from the ADCs. The data is clocked out of the CS4298 on the rising edge of BIT\_CLK. A series terminating resistor of 47  $\Omega$  should be connected on this signal as close to the CS4298 as possible.

**XTL\_IN - Crystal Input**

This pin accepts either a crystal, with the other pin attached to XTL\_OUT, or an external CMOS clock. XTL\_IN must have a crystal or clock source attached for proper operation except when operating in BIT\_CLK mode. The crystal frequency must be 24.576 MHz and designed for fundamental mode, parallel resonance operation.

---

**XTL\_OUT - Crystal Output**

This pin is used for a crystal placed between this pin and XLT\_IN. If an external clock is used on XTL\_IN or the codec is in BIT\_CLK mode, this pin must be left floating with no traces or components connected to it.

**ID1#, ID0# - Codec ID, Inputs**

These pins select the codec ID and mode of operation for the CS4298. They are sampled after the rising edge of RESET# and not used after. These inputs have internal 100 kΩ pull-ups and should be left floating for a logic 0 or tied to analog ground for a logic 1. The pins utilize inverted logic, so the condition of both pins floating sets the codec to primary mode while any other combination sets the codec to a secondary mode. In primary mode, the codec is always clocked from an external crystal or an external oscillator connected to the XTL\_IN and/or XTL\_OUT pins with BIT\_CLK as an output. In secondary mode, the clocking mechanism is determined by the state of the BCM# pin with BIT\_CLK always being an input.

**BCM# - BIT\_CLK Mode, Input**

This pin selects the secondary mode clocking mechanism. BCM# is sampled after the rising edge of RESET# and not used after. In codec secondary mode (ID1# and or ID0# grounded), grounding this input will select BIT\_CLK mode. In this mode, BIT\_CLK is defined as an input and all internal timing will be derived from the BIT\_CLK signal and no connections should be made to XTAL\_IN and XTAL\_OUT. When BCM# is floating, all timing will be derived from the XTAL\_IN pin. In this case, XTAL\_IN must be synchronous to BIT\_CLK. In primary mode, BCM# must be left floating.

**S/PDIF\_OUT - Sony/Phillips Digital Interface, Output**

This pin generates IEC 958 consumer compatible (S/PDIF) digital output from the CS4298 using output slots 6 and 9 when the SPDIF\_EN bit in register 68h is set. For use with consumer audio equipment, the output may be used to drive an RS422A compliant interface through an isolation transformer, or a CP-1201 compliant interface through a TOSLINK module. When S/PDIF\_OUT is not being used this output is driven to a logic '0'.

**GPIO[9:0] - General Purpose Input/Output**

These GPIO pins are used to control modem DAAs and other discrete digital functions. When a GPIO pin is configured as an input, it behaves as a Schmitt trigger input with 350 mV of hysteresis at 5 V and 220 mV of hysteresis at 3.3 V. When a GPIO pin is configured as an output, it may function as a normal CMOS output (4 mA drive) or as an open drain output. GPIO pins power up in the high impedance state (tri-state).

## 8.2 Analog I/O Pins

### **MIC1 - Analog Mono Source, Input**

This analog input is a monophonic source to the analog output mixer. It is intended to be used as a desktop microphone connection to the audio subsystem. This input is MUX selectable to the input mixer with the MIC2 input source. The maximum allowable input is 1 V<sub>RMS</sub> (sinusoidal). If the 20 dB internal boost is enabled, the maximum allowable input is 100 mV<sub>RMS</sub> (sinusoidal). This input is internally biased at the Vrefout voltage reference and requires AC coupling to external circuitry. If this input is not used, it should be AC coupled to analog ground.

### **MIC2 - Analog Mono Source, Input**

This analog input is a monophonic source to the analog output mixer. It is intended to be used as an alternate microphone connection to the audio subsystem. This input is MUX selectable to the input mixer with the MIC1 input source. The maximum allowable input is 1 V<sub>RMS</sub> (sinusoidal). If the 20 dB internal boost is enabled, the maximum allowable input is 100 mV<sub>RMS</sub> (sinusoidal). This input is internally biased at the Vrefout voltage reference and requires AC coupling to external circuitry. If this input is not used, it should be AC coupled to analog ground.

### **LINE\_IN\_L and LINE\_IN\_R- Analog Line Source, Inputs**

These inputs form a stereo input pair to the CS4298. The maximum allowable input is 1 V<sub>RMS</sub> (sinusoidal). These inputs are internally biased at the Vrefout voltage reference. AC coupling to external circuitry is required. If these inputs are not used, they should both be connected to the Vrefout pin or both AC coupled, with separate AC coupling caps, to analog ground.

### **CD\_L and CD\_R - Analog CD Source, Inputs**

These inputs form a stereo input pair to the CS4298. It is intended to be used for the Red Book CD audio connection to the audio subsystem. The maximum allowable input is 1 V<sub>RMS</sub> (sinusoidal). These inputs are internally biased at the Vrefout voltage reference. AC coupling to external circuitry is required. If these inputs are not used, they should both be connected to the Vrefout pin or both AC coupled, with separate AC coupling caps, to analog ground.

### **CD\_GND - Analog CD Common Source, Input**

This analog input is used to remove common mode noise from Red Book CD audio signals. The impedance on the input signal path should be one half the impedance on the CD\_L and CD\_R input paths. This pin requires AC coupling to external circuitry. If this input is not used, it should be connected to the Vrefout pin or AC coupled to analog ground.

**VIDEO\_L and VIDEO\_R - Analog Video Audio Source, Inputs**

These inputs form a stereo input pair to the CS4298. It is intended to be used for the audio signal output of a video device. The maximum allowable input is 1 V<sub>RMS</sub> (sinusoidal). These inputs are internally biased at the Vrefout voltage reference. AC coupling to external circuitry is required. If these inputs are not used, they should both be connected to the Vrefout pin or both AC coupled, with separate AC coupling caps, to analog ground.

**AUX\_L and AUX\_R - Analog Auxiliary Source, Inputs**

These inputs form a stereo input pair to the CS4298. The maximum allowable input is 1 V<sub>RMS</sub> (sinusoidal). These inputs are internally biased at the Vrefout voltage reference. AC coupling to external circuitry is required. If these inputs are not used, they should both be connected to the Vrefout pin or both AC coupled, with separate AC coupling caps, to analog ground.

**LINE\_OUT\_L and LINE\_OUT\_R - Analog Line Level Outputs**

These signals are analog outputs from the stereo output mixer. The full scale output voltage for output is nominally 1 V<sub>RMS</sub> and is internally biased at the Vrefout voltage reference. It is required to either AC couple these pins to external circuitry or DC couple them to a buffer op-amp biased at the Vrefout voltage. These pins need a 680 pF NPO capacitor attached to analog ground.

**ALT\_LINE\_OUT\_L and ALT\_LINE\_OUT\_R - Analog Alternate Line Level Outputs**

These signals are analog outputs from the stereo output mixer. The full scale output voltage for each output is nominally 1 V<sub>RMS</sub> and is internally biased at the Vrefout voltage reference. It is required to either AC couple these pins to external circuitry or DC couple them to a buffer op-amp biased at the Vrefout voltage. These pins need a 680 pF NPO capacitor attached to analog ground.

**8.3 *Filter and Reference Pins*****REFFLT - Internal Reference Voltage, Input**

This is the voltage reference used internal to the part. A 0.1 μF and a 1 μF (must not be larger than 1 μF) capacitor with short, wide traces must be connected to this pin. No other connections should be made to this pin.

**Vrefout - Voltage Reference, Output**

All analog inputs and outputs are centered around Vrefout which is nominally 2.2 Volts. This pin may be used to level shift external circuitry, however any external loading should be buffered.

**AFLT1 - Left Channel Antialiasing Filter Input**

This pin needs a 390 pF NPO capacitor attached to analog ground.

**AFLT2 - Right Channel Antialiasing Filter Input**

This pin needs a 390 pF NPO capacitor attached to analog ground.

**FLTI - 3D Filter Input**

A 1000 pF capacitor must be attached between this pin and FLTO if the 3D function is used.

**FLTO - 3D Filter Output**

A 1000 pF capacitor must be attached between this pin and FLTI if the 3D function is used.

**FLT3D - 3D Filter**

A 0.01  $\mu$ F capacitor must be attached from this pin to AGND if the 3D function is used.

**8.4 Modem/Telephony****MRX+, MRX- - Modem Line Differential Receive, Inputs**

This differential input receive pair connects to a 2- to 4-wire hybrid converter or an integrated DAA and is used to sample the analog phone line signal. The maximum full scale differential input is 3.0 Vp-p. These pins may be used in single ended fashion by connecting the input to MRX+ and AC-grounding the MRX- pin, or by tying one of the two inputs to Vrefout to provide DC-biasing.

**HRX+, HRX- - Handset Differential Receive, Inputs**

This differential input receive pair connects to a 2- to 4-wire hybrid converter and is used to communicate with the local handset. These input pins may also be used to interface to a second telephone line. The maximum full scale differential input is 3.0 Vp-p. These pins may be used in single ended fashion by connecting the input to HRX+ and AC-grounding the HRX- pin, or by tying one of the two inputs to Vrefout to provide DC-biasing.

**MTX+, MTX- - Modem Line Differential Transmit, Outputs**

This differential transmit output pair connects the a 2- to 4-wire hybrid converter or an integrated DAA and is used to transmit over the analog phone line. The maximum full scale differential output is 5.6 Vp-p (MTX+ to MTX-). Each output pin is internally biased at the Vrefout voltage. These pins may be used in single ended fashion by using one leg of the differential output pair. The maximum output for each pin is 2.8 Vp-p or 1.0 Vrms.

**HTX+, HTX- - Handset Differential Transmit, Outputs**

This differential transmit output pair connects the a 2- to 4-wire hybrid converter or an integrated DAA and is used to transmit over the analog phone line. The maximum full scale differential output is 5.6 Vp-p (HTX+ to HTX-). Each output pin is internally biased at the Vrefout voltage. These pins may be used in single ended fashion by using one leg of the differential output pair. The maximum output for each pin is 2.8 Vp-p or 1.0 Vrms.

### 8.5 Power Supplies

#### **DVdd1, DVdd2 - Digital Supply Voltage**

These pins provide the digital supply voltage for the AC-link section of the CS4298. These pins may be tied to +5 V digital or to +3.3 V digital. The CS4298 and digital controller's AC-link should share a common digital supply.

#### **DVss1, DVss2 - Digital Ground**

These pins are the digital ground connection for the AC-link section of the CS4298. These pins should be isolated from analog ground currents.

#### **AVdd1, AVdd2, AVdd3, AVdd4 - Analog Supply Voltage**

These pins provide the analog supply voltage for the analog and mixed signal sections of the CS4298. These pins must be tied to +5 V analog supply. It is strongly recommended that +5 V be generated from a voltage regulator to ensure proper supply currents and noise immunity from the rest of the system.

#### **AVss1, AVss2, AVss3, AVss4, AVss5 - Analog Ground**

These pins are the ground connection for the analog, mixed signal, and substrate sections of the CS4298. These pins should be isolated from digital ground currents.



---

## 9. PARAMETER AND TERM DEFINITIONS

### AC '97 Specification

Refers to the *Audio Codec '97 Component Specification Ver 2.1* published by Intel<sup>®</sup> Corporation [].

### AC '97 Controller or Controller

Refers to the control chip which interfaces to the Codec's AC-link. This has been also called *DC '97* for Digital Controller '97 [].

### AC '97 Registers or Codec registers

Refers to the 64-field register map defined in the AC '97 Specification.

### ADC

Refers to a single Analog-to-Digital converter in the Codec. "ADCs" refers to the stereo pair of Analog-to-Digital converters.

### DAC

A single Digital-to-Analog converter in the Codec "DACs" refers to the stereo pair of Digital-to-Analog converters.

### SRC

Sample Rate converter. Converts data derived at one sample rate to a differing sample rate.

### Codec

Refers to the chip containing the ADCs, DACs, and analog mixer. In this data sheet, the Codec is the CS4297A9.

### FFT

Fast Fourier Transform.

### Resolution

The number of bits in the output words to the DACs, and in the input words to the ADCs.

### Differential Nonlinearity

The worst case deviation from the ideal code width. Units in LSB.

### dB FS A

dB FS is defined as dB relative to full-scale. The "A" indicates an A weighting filter was used.

**Frequency Response (FR)**

FR is the deviation in signal level verses frequency. The 0 dB reference point is 1 kHz. The amplitude corner,  $A_c$ , lists the maximum deviation in amplitude above and below the 1 kHz reference point. The listed minimum and maximum frequencies are guaranteed to be within the  $A_c$  from minimum frequency to maximum frequency inclusive.

**Dynamic Range (DR)**

DR is the ratio of the RMS full-scale signal level divided by the RMS sum of the noise floor, in the presence of a signal, available at any instant in time (no change in gain settings between measurements). Measured over a 20 Hz to 20 kHz bandwidth with units in dB FS A.

**Total Harmonic Distortion plus Noise (THD+N)**

THD+N is the ratio of the RMS sum of all non-fundamental frequency components, divided by the RMS full-scale signal level. It is tested using a -3 dB FS input signal and is measured over a 20 Hz to 20 kHz bandwidth with units in dB FS.

**Signal to Noise Ratio (SNR)**

SNR, similar to DR, is the ratio of an arbitrary sinusoidal input signal to the RMS sum of the noise floor, in the presence of a signal. It is measured over a 20 Hz to 20 kHz bandwidth with units in dB.

**S/PDIF**

Sony/Phillips Digital Interface. This interface was established as a means of digitally interconnecting consumer audio equipment. The documentation for S/PDIF has been superseded by the IEC-958 consumer digital interface document.

**Interchannel Isolation**

The amount of 1 kHz signal present on the output of the grounded AC-coupled line input channel with 1 kHz, 0 dB, signal present on the other line input channel. Units in dB.

**Interchannel Gain Mismatch**

For the ADCs, the difference in input voltage to get an equal code on both channels. For the DACs, the difference in output voltages for each channel when both channels are fed the same code. Units in dB.

**PATHS**

A-D: Analog in, through the ADC, onto the serial link.

D-A: Serial interface inputs through the DAC to the analog output.

A-A: Analog in to Analog out (analog mixer).

**10. REFERENCES**

Intel, Audio Codec '97 Component Specification, Revision 2.1, May 22, 1998.  
<http://developer.intel.com/pc-supp/platform/ac97/>

11. PACKAGE DIMENSIONS

64L TQFP PACKAGE DRAWING

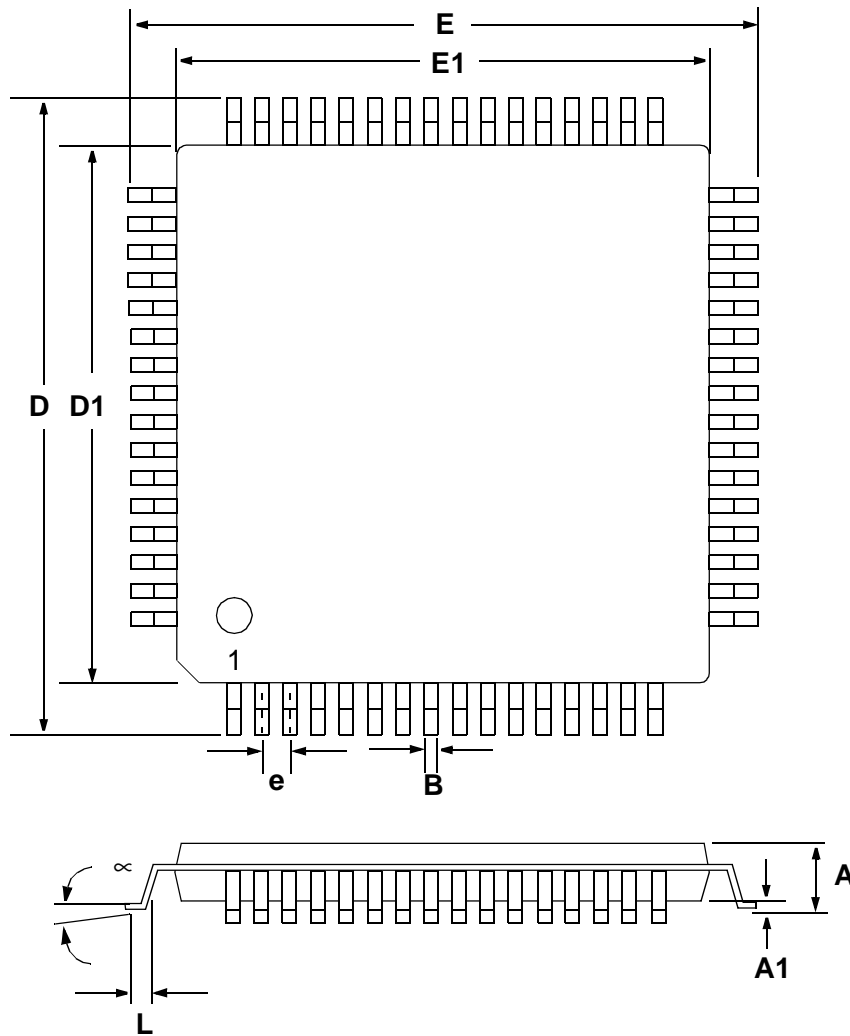

DIM	INCHES		MILLIMETERS	
	MIN	MAX	MIN	MAX
A	---	0.063	---	1.60
A1	0.002	0.006	0.05	0.15
B	0.007	0.011	0.17	0.27
D	0.461	0.484	11.70	12.30
D1	0.390	0.398	9.90	10.10
E	0.461	0.484	11.70	12.30
E1	0.390	0.398	9.90	10.10
e*	0.016	0.024	0.40	0.60
L	0.018	0.030	0.45	0.75
∞	0.000°	7.000°	0.00°	7.00°

\* Nominal pin pitch is 0.50 mm

Controlling dimension is mm.

JEDEC Designation: MS026

SMART  
Analog™