

### FEATURES

- 34 MHz Full Power Bandwidth
- ±0.1 dB Gain Flatness to 8 MHz
- 72 dB Crosstalk Rejection @ 10 MHz
- 0.03°/0.01% Differential Phase/Gain
- Cascadable for Switch Matrices
- MIL-STD-883 Compliant Versions Available

### APPLICATIONS

- Video Routing
- Medical Imaging
- Electro Optics
- ECM Systems
- Radar Systems
- Data Acquisition

### GENERAL DESCRIPTION

The AD9300 is a monolithic high speed video signal multiplexer usable in a wide variety of applications.

Its four channels of video input signals can be randomly switched at megahertz rates to the single output. In addition, multiple devices can be configured in either parallel or cascade arrangements to form switch matrices. This flexibility in using the AD9300 is possible because the output of the device is in a high-impedance state when the chip is not enabled; when the chip is enabled, the unit acts as a buffer with a high input impedance and low output impedance.

An advanced bipolar process provides fast, wideband switching capabilities while maintaining crosstalk rejection of 72 dB at 10 MHz. Full power bandwidth is a minimum 27 MHz. The device can be operated from ±10 V to ±15 V power supplies.

### FUNCTIONAL BLOCK DIAGRAM

(Based on Cerdip)

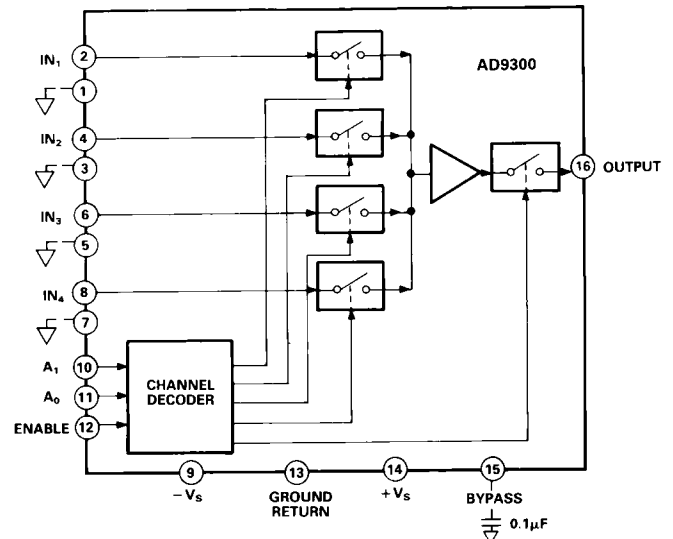

The AD9300K is available in a 16-pin ceramic DIP and a 20-pin PLCC and is designed to operate over the commercial temperature range of 0°C to +70°C. The AD9300TQ is a hermetic 16-pin ceramic DIP for military temperature range (-55°C to +125°C) applications. This part is also available processed to MIL-STD-883. The AD9300 is available in a 20-pin LCC as the model AD9300TE, which operates over a temperature range of -55°C to +125°C.

The AD9300 Video Multiplexer is available in versions compliant with MIL-STD-883. Refer to the Analog Devices *Military Products Databook* or current AD9300/883B data sheet for detailed specifications.

### PIN DESIGNATIONS

#### DIP

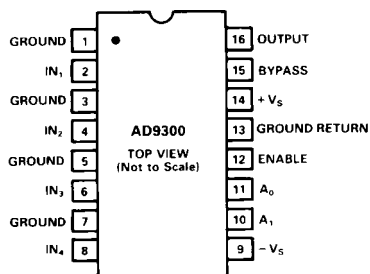

#### LCC and PLCC

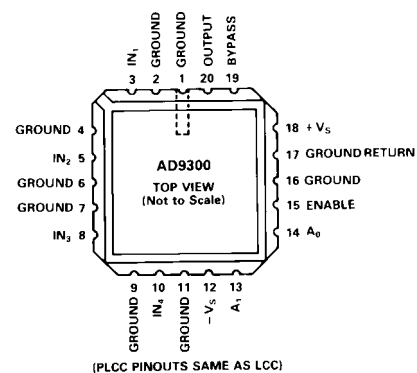

### REV. A

Information furnished by Analog Devices is believed to be accurate and reliable. However, no responsibility is assumed by Analog Devices for its use, nor for any infringements of patents or other rights of third parties which may result from its use. No license is granted by implication or otherwise under any patent or patent rights of Analog Devices.

# AD9300—SPECIFICATIONS

## ELECTRICAL CHARACTERISTICS ( $\pm V_S = \pm 12\text{ V} \pm 5\%$ ; $C_L = 10\text{ pF}$ ; $R_L = 2\text{ k}\Omega$ , unless otherwise noted)

Parameter (Conditions)	Temp	Test Level	COMMERCIAL 0°C to +70°C AD9300KQ/KP			Units
			Min	Typ	Max	
<b>INPUT CHARACTERISTICS</b>						
Input Offset Voltage	+25°C	I		3	10	mV
Input Offset Voltage	Full	VI			14	mV
Input Offset Voltage Drift <sup>2</sup>	Full	V		75		$\mu\text{V}/^\circ\text{C}$
Input Bias Current	+25°C	I		15	37	$\mu\text{A}$
Input Bias Current	Full	VI			55	$\mu\text{A}$
Input Resistance	+25°C	V		3.0		M $\Omega$
Input Capacitance	+25°C	V		2		pF
Input Noise Voltage (dc to 8 MHz)	+25°C	V		16		$\mu\text{V rms}$
<b>TRANSFER CHARACTERISTICS</b>						
Voltage Gain <sup>3</sup>	+25°C	I	0.990	0.994		V/V
Voltage Gain <sup>3</sup>	Full	VI	0.985			V/V
DC Linearity <sup>4</sup>	+25°C	V		0.01		%
Gain Tolerance ( $V_{IN} = \pm 1\text{ V}$ )						
dc to 5 MHz	+25°C	I		0.05	0.1	dB
5 MHz to 8 MHz	+25°C	I		0.1	0.3	dB
Small-Signal Bandwidth ( $V_{IN} = 100\text{ mV p-p}$ )	+25°C	V		350		MHz
Full Power Bandwidth <sup>5</sup> ( $V_{IN} = 2\text{ V p-p}$ )	+25°C	I	27	34		MHz
Output Swing	Full	VI	$\pm 2$			V
Output Current (Sinking @ = +25°C)	+25°C	V		5		mA
Output Resistance	+25°C	IV, V		9	15	$\Omega$
<b>DYNAMIC CHARACTERISTICS</b>						
Slew Rate <sup>6</sup>	+25°C	I	170	215		V/ $\mu\text{s}$
Settling Time (to 0.1% on $\pm 2\text{ V}$ Output)	+25°C	IV		70	100	ns
Overshoot						
To T-Step <sup>7</sup>	+25°C	V		<0.1		%
To Pulse <sup>8</sup>	+25°C	V		<10		%
Differential Phase <sup>9</sup>	+25°C	IV		0.03	0.1	$^\circ$
Differential Gain <sup>9</sup>	+25°C	IV		0.01	0.1	%
Crosstalk Rejection						
Three Channels <sup>10</sup>	+25°C	IV	68	72		dB
One Channel <sup>11</sup>	+25°C	IV	70	76		dB
<b>SWITCHING CHARACTERISTICS<sup>12</sup></b>						
$A_X$ Input to Channel HIGH Time <sup>13</sup> ( $t_{HIGH}$ )	+25°C	I		40	50	ns
$A_X$ Input to Channel LOW Time <sup>14</sup> ( $t_{LOW}$ )	+25°C	I		35	45	ns
Enable to Channel ON Time <sup>15</sup> ( $t_{ON}$ )	+25°C	I		35	45	ns
Enable to Channel OFF Time <sup>16</sup> ( $t_{OFF}$ )	+25°C	I		35	45	ns
Switching Transient <sup>17</sup>	+25°C	V		60		mV
<b>DIGITAL INPUTS</b>						
Logic "1" Voltage	Full	VI	2			V
Logic "0" Voltage	Full	VI			0.8	V
Logic "1" Current	Full	VI			5	$\mu\text{A}$
Logic "0" Current	Full	VI			1	$\mu\text{A}$
<b>POWER SUPPLY</b>						
Positive Supply Current (+12 V)	+25°C	I		13	16	mA
Positive Supply Current (+12 V)	Full	VI		13	16	mA
Negative Supply Current (-12 V)	+25°C	I		12.5	15	mA
Negative Supply Current (-12 V)	Full	VI		12.5	16	mA
Power Supply Rejection Ratio ( $\pm V_S = \pm 12\text{ V} \pm 5\%$ )	Full	VI	67	75		dB
Power Dissipation ( $\pm 12\text{ V}$ ) <sup>18</sup>	+25°C	V		306		mW

## NOTES

- <sup>1</sup>Permanent damage may occur if any one absolute maximum rating is exceeded. Functional operation is not implied, and device reliability may be impaired by exposure to higher-than-recommended voltages for extended periods of time.
- <sup>2</sup>Measured at extremes of temperature range.
- <sup>3</sup>Measured as slope of  $V_{OUT}$  versus  $V_{IN}$  with  $V_{IN} = \pm 1$  V.
- <sup>4</sup>Measured as worst deviation from endpoint fit with  $V_{IN} = \pm 1$  V.
- <sup>5</sup>Full Power Bandwidth (FPBW) based on Slew Rate (SR).  $FPBW = SR/2\pi V_{PEAK}$
- <sup>6</sup>Measured between 20% and 80% transition points of  $\pm 1$  V output.
- <sup>7</sup>T-Step =  $\text{Sin}^2 \times \text{Step}$ , when Step between 0 V and +700 mV points has 10% to 90% risetime = 125 ns.
- <sup>8</sup>Measured with a pulse input having slew rate  $>250$  V/ $\mu$ s.
- <sup>9</sup>Measured at output between 0.28 V dc and 1.0 V dc with  $V_{IN} = 284$  mV p-p at 3.58 MHz and 4.43 MHz.
- <sup>10</sup>This specification is critically dependent on circuit layout. Value shown is measured with selected channel grounded and 10 MHz 2 V p-p signal applied to remaining three channels. If selected channel is grounded through 75  $\Omega$ , value is approximately 6 dB higher.
- <sup>11</sup>This specification is critically dependent on circuit layout. Value shown is measured with selected channel grounded and 10 MHz 2 V p-p signal applied to one other channel. If selected channel is grounded through 75  $\Omega$ , value is approximately 6 dB higher. Minimum specification in ( ) applies to DIPs.
- <sup>12</sup>Consult system timing diagram.
- <sup>13</sup>Measured from address change to 90% point of  $-2$  V to  $+2$  V output LOW-to-HIGH transition.
- <sup>14</sup>Measured from address change to 90% point of  $+2$  V to  $-2$  V output HIGH-to-LOW transition.
- <sup>15</sup>Measured from 50% transition point of ENABLE input to 90% transition of 0 V to  $-2$  V and 0 V to  $+2$  V output.
- <sup>16</sup>Measured from 50% transition point of ENABLE input to 10% transition of  $+2$  V to 0 V and  $-2$  V to 0 V output.
- <sup>17</sup>Measured while switching between two grounded channels.
- <sup>18</sup>Maximum power dissipation is a package-dependent parameter related to the following typical thermal impedances:
- |                |   |
|----------------|---|
| 16-Pin Ceramic | $\theta_{JA} = 87^\circ\text{C/W}$ ; $\theta_{JC} = 25^\circ\text{C/W}$ |
| 20-Pin LCC     | $\theta_{JA} = 74^\circ\text{C/W}$ ; $\theta_{JC} = 10^\circ\text{C/W}$ |
| 20-Pin PLCC    | $\theta_{JA} = 71^\circ\text{C/W}$ ; $\theta_{JC} = 26^\circ\text{C/W}$ |

Specifications subject to change without notice.

**ABSOLUTE MAXIMUM RATINGS<sup>1</sup>**

Supply Voltages ( $\pm V_S$ )	$\pm 16$ V
Analog Input Voltage Each Input ( $IN_1$ thru $IN_4$ )	$\pm 3.5$ V
Differential Voltage Between Any Two Inputs ( $IN_1$ thru $IN_4$ )	5 V
Digital Input Voltages ( $A_0$ , $A_1$ , ENABLE)	$-0.5$ V to $+5.5$ V
Output Current	
Sinking	6.0 mA
Sourcing	6.0 mA
Operating Temperature Range	
AD9300KQ/KP	$0^\circ\text{C}$ to $+70^\circ\text{C}$
Storage Temperature Range	$-65^\circ\text{C}$ to $+150^\circ\text{C}$
Junction Temperature	$+175^\circ\text{C}$
Lead Soldering (10 sec)	$+300^\circ\text{C}$

**EXPLANATION OF TEST LEVELS**

Test Level I	– 100% production tested.
Test Level II	– 100% production tested at $+25^\circ\text{C}$ , and sample tested at specified temperatures.
Test Level III	– Sample tested only.
Test Level IV	– Parameter is guaranteed by design and characterization testing.
Test Level V	– Parameter is a typical value only.
Test Level VI	– All devices are 100% production tested at $+25^\circ\text{C}$ . 100% production tested at temperature extremes for military temperature devices; sample tested at temperature extremes for commercial/industrial devices.

**ORDERING GUIDE**

Device	Temperature Range	Description	Package Option <sup>1</sup>
AD9300KQ	$0^\circ\text{C}$ to $+70^\circ\text{C}$	16-Pin Cerdip, Commercial	Q-16
AD9300TE/883B <sup>2</sup>	$-55^\circ\text{C}$ to $+125^\circ\text{C}$	20-Pin LCC, Military Temperature	E-20A
AD9300TQ/883B <sup>2</sup>	$-55^\circ\text{C}$ to $+125^\circ\text{C}$	16-Pin Cerdip, Military Temperature	Q-16
AD9300KP	$0^\circ\text{C}$ to $+70^\circ\text{C}$	20-Pin PLCC, Commercial	P-20A

## NOTES

<sup>1</sup>E = Ceramic Leadless Chip Carrier; P = Plastic Leaded Chip Carrier; Q = Cerdip.

<sup>2</sup>For specifications, refer to Analog Devices *Military Products Databook*.

**CAUTION**

ESD (electrostatic discharge) sensitive device. Electrostatic charges as high as 4000 V readily accumulate on the human body and test equipment and can discharge without detection. Although the AD9300 features proprietary ESD protection circuitry, permanent damage may occur on devices subjected to high energy electrostatic discharges. Therefore, proper ESD precautions are recommended to avoid performance degradation or loss of functionality.



# AD9300

## AD9300 BURN-IN DIAGRAM

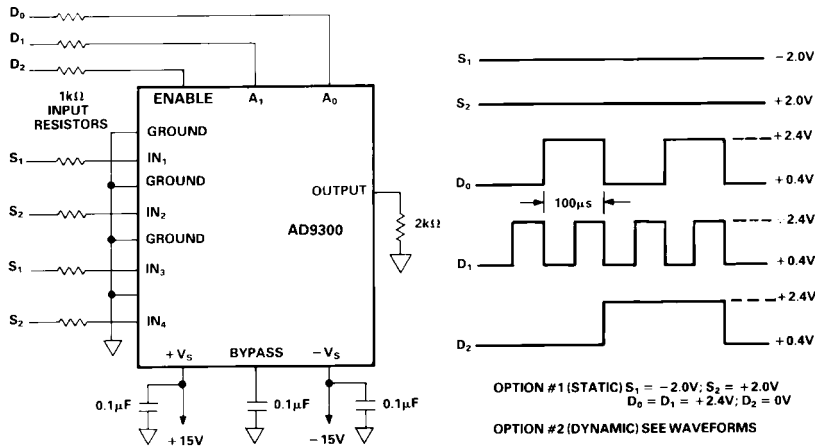

ALL RESISTORS  $\pm 5\%$   
 ALL CAPACITORS  $\pm 20\%$   
 ALL SUPPLY VOLTAGES  $\pm 5\%$

## SUGGESTED LAYOUT OF AD9300 PC BOARD

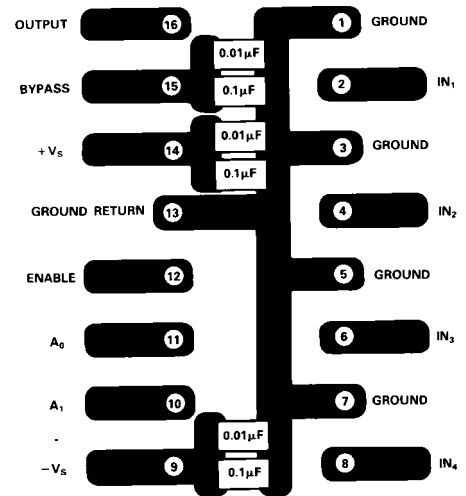

Suggested Layout of AD9300 PC Board  
 (Bottom View - Not to Scale)  
 Component Side Should be Ground Plane

## FUNCTIONAL DESCRIPTION

- IN<sub>1</sub>-IN<sub>4</sub>** Four analog input channels.
- GROUND** Analog input shielding grounds, not internally connected. Connect each to external low-impedance ground as close to device as possible.
- A<sub>0</sub>** One of two TTL decode control lines required for channel selection. See Logic Truth Table.
- A<sub>1</sub>** One of two TTL decode control lines required for channel selection. See Logic Truth Table.
- ENABLE** TTL-compatible chip enable. In enabled mode (logic HIGH), output signal tracks selected input channel; in disabled mode (logic LOW), output is high impedance and no signal appears at output.
- V<sub>S</sub>** Negative supply voltage; normally -10 V dc to -15 V dc.
- +V<sub>S</sub>** Positive supply voltage; normally +10 V dc to +15 V dc.
- OUTPUT** Analog output. Tracks selected input channel when enabled.
- BYPASS** Bypass terminal for internal bias line; must be decoupled externally to ground through 0.1 μF capacitor.
- GROUND RETURN** Analog signal and power supply ground return.

## METALIZATION PHOTOGRAPH

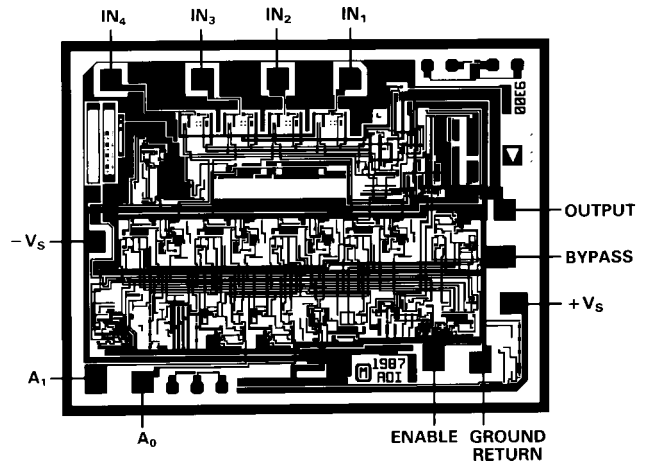

## MECHANICAL INFORMATION

Die Dimensions . . . . . 84 × 104 × 18 (max) mils  
 Pad Dimensions . . . . . 4 × 4 (min) mils  
 Metalization . . . . . Aluminum  
 Backing . . . . . None  
 Substrate Potential . . . . . -V<sub>S</sub>  
 Passivation . . . . . Oxynitride  
 Die Attach . . . . . Gold Eutectic  
 Bond Wire . . . . . 1.25 mil, Aluminum; Ultrasonic Bonding  
 or 1 mil, Gold; Gold Ball Bonding

## LOGIC TRUTH TABLE

ENABLE	A <sub>1</sub>	A <sub>0</sub>	OUTPUT
0	X	X	High Z
1	0	0	IN <sub>1</sub>
1	0	1	IN <sub>2</sub>
1	1	0	IN <sub>3</sub>
1	1	1	IN <sub>4</sub>

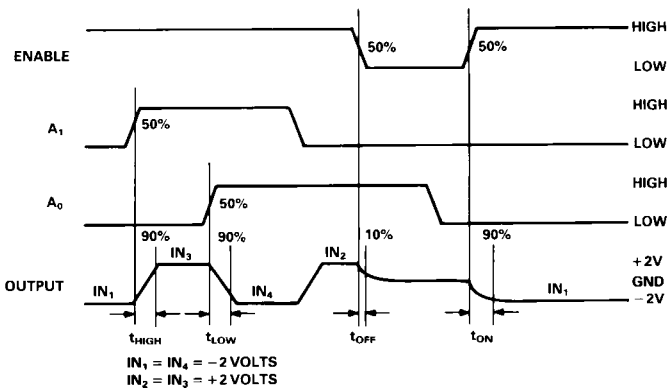

AD9300 Timing Diagram

## THEORY OF OPERATION

Refer to the functional block diagram of the AD9300.

As shown in the drawing, this diagram is based on the pinouts of the DIP packaging of the models AD9300KQ and AD9300TQ. The AD9300KP and AD9300TE are packaged in 20-pin surface mount packages. The extra pins are used for ground connections; the theory of operation remains the same.

The AD9300 Video Multiplexer allows the user to connect any one of four analog input channels ( $IN_1$ – $IN_4$ ) to the output of the device and to switch between channels at megahertz rates.

The input channel, which is connected to the output is determined by a 2-bit TTL digital code applied to  $A_0$  and  $A_1$ . The selected input will not appear at the output unless a digital "1" is also applied to the ENABLE input pin; unless the output is enabled, it is a high impedance. Necessary combinations to accomplish channel selection are shown in the Logic Truth Table.

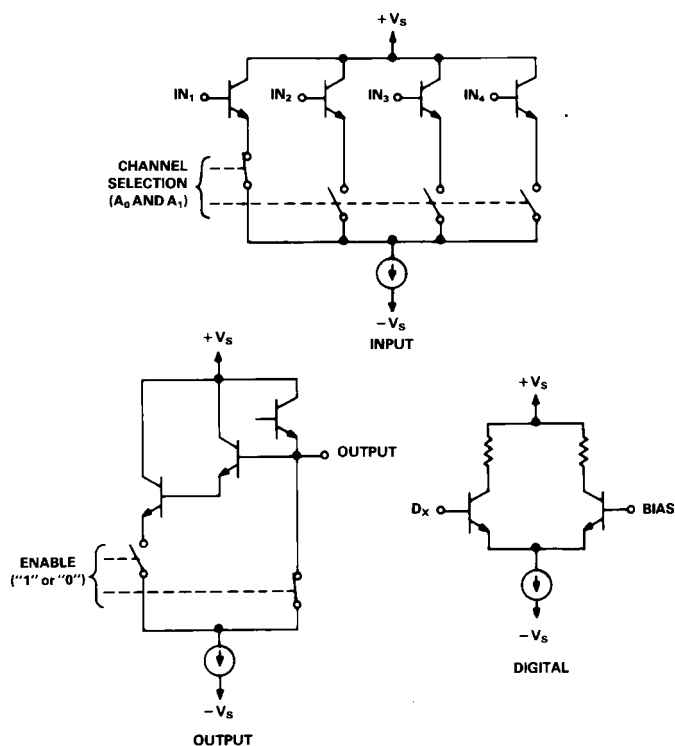

Figure 1. Input and Output Equivalent Circuits

Bipolar construction used in the AD9300 ensures that the input impedance of the device remains high and will not vary with power supply voltages. This characteristic makes the AD9300, in effect, a switchable-input buffer. An onboard bias network makes the performance of the AD9300 independent of applied supply voltages, which can have any nominal value from  $\pm 10$  V dc to  $\pm 15$  V dc.

Although the primary application for the AD9300 is the routing of video signals, the harmonic and dynamic attributes of the device make it appropriate for other applications. The AD9300 has exceptional performance when switching video signals and can also be used for switching other analog signals requiring greater dynamic range and/or precision than those in video.

As shown in Figure 1, each analog input is connected to the base of a bipolar transistor. If Channel 1 is selected, a current switch is closed and routes current through the input transistor for Channel 1.

If Channel 2 is then selected by the digital inputs, the current switch for Channel 1 is opened and the current switch for Channel 2 is closed. This causes current to be routed away from the Channel 1 transistor and into the Channel 2 input transistor. Whenever a channel's input device is carrying current, the analog input applied to that channel is passed to the output stage.

The operation of the output stage is similar to that of the input stages. Whenever the output stage is enabled with a HIGH digital "1" signal at the ENABLE pin, the output transistor will carry current and pass the selected analog input.

When the output stage is disabled (by virtue of the ENABLE pin being driven LOW with a digital "0"), the output current switch is opened. This routes the current to other circuits within the AD9300 that keep the output transistor biased "off." These circuits require approximately  $1 \mu\text{A}$  of bias current from the load connected to the output of the multiplexer. In the absence of a terminating load and the resulting dc bias, the output of the AD9300 "floats" at  $-2.5$  V.

In summary, when the AD9300 is enabled by the ENABLE pin being driven HIGH with a digital "1," the selected analog input channel acts as a buffer for the input and the output of the multiplexer is a low impedance. When the AD9300 is disabled with a digital "0" LOW signal, the selected channel acts as an open switch for the input, and the output of the unit becomes a high impedance. This characteristic allows the user to wire-or several AD9300 Analog Multiplexers together to form switch matrices.

# AD9300

## AD9300 APPLICATIONS

To ensure optimum performance from circuits using the AD9300, it is important to follow a few basic rules that apply to all high speed devices.

A large, low-impedance ground plane under the AD9300 is critical. Generally, GROUND and GROUND RETURN connections should be connected solidly to this plane. GROUND pin connections are signal isolation grounds that are not

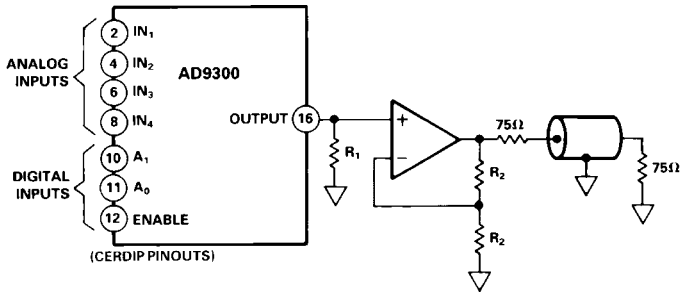

Figure 2. 4 x 1 AD9300 Multiplexer with Buffered Output Driving 75 Ω Coaxial Cable

connected internally; they can be left unconnected, but there may be some degradation in crosstalk rejection. GROUND RETURN, on the other hand, serves as the internal ground reference for the AD9300 and, without exception, should be connected to the ground plane.

The output stage of the unit is capable of driving a 2 kΩ||10 pF load. Larger capacitive loads may limit full power bandwidth and increase t<sub>OFF</sub> (the interval between the 50% point of the ENABLE high-to-low transition and the instant the output becomes a high impedance).

For applications such as driving cables (see Figure 2), output buffers are recommended.

It is recommended that the AD9300 be soldered directly into circuit boards rather than using socket assemblies. If sockets must be used, individual pin sockets are preferred rather than a socket assembly. A second requirement for proper high speed design involves decoupling the power supply and internal bias supply lines from ground to improve noise immunity. Chip capacitors are recommended for connecting 0.1 μF and 0.01 μF capacitors between ground and the ±V<sub>S</sub> supplies (Pins 9 and 14) and the BYPASS connection (Pin 15).

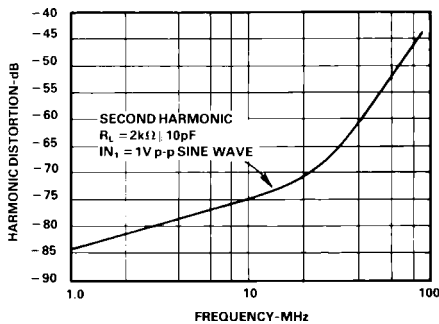

Figure 3. Harmonic Distortion vs. Frequency

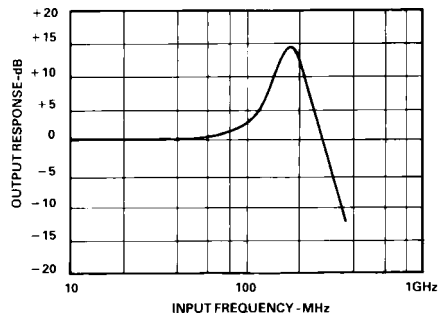

Figure 4. Output vs. Frequency

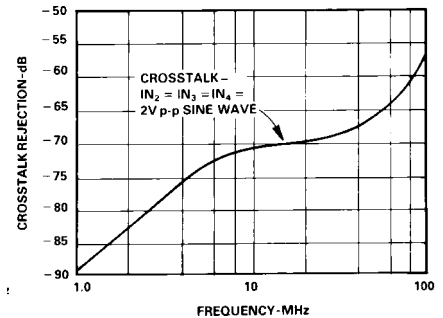

Figure 5. Crosstalk vs. Frequency

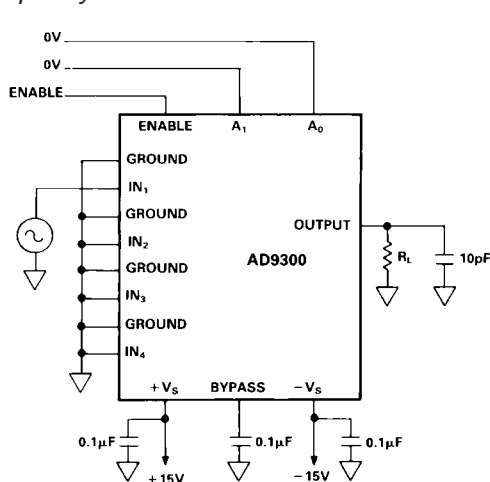

Figure 6. Test Circuit for Harmonic Distortion, Pulse Response, T-Step Response and Disable Characteristics

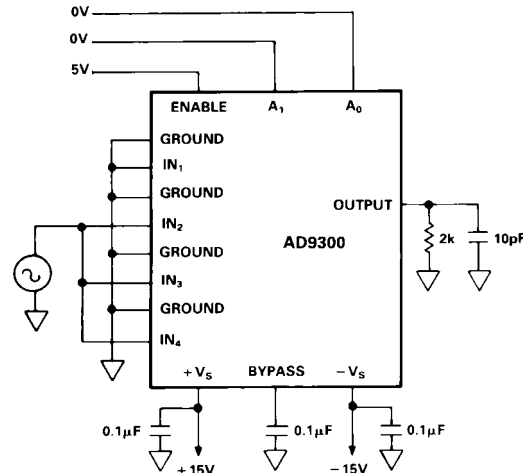

Figure 7. Crosstalk Rejection Test Circuit



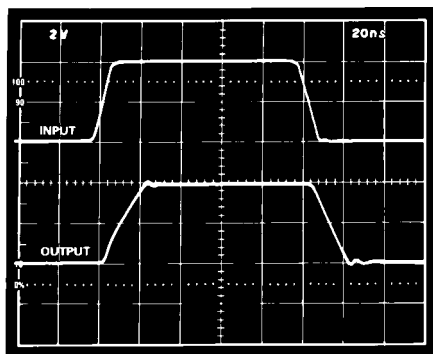

Figure 8. Pulse Response

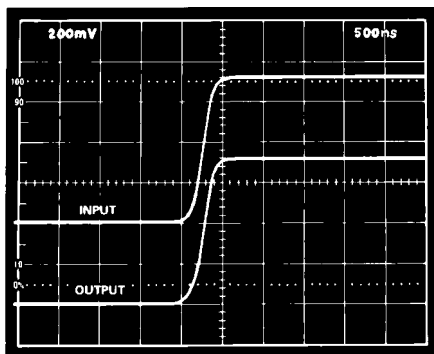

Figure 9. T-Step Response

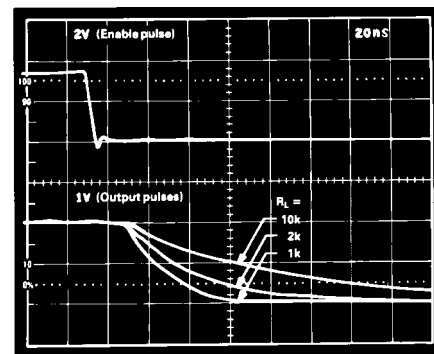
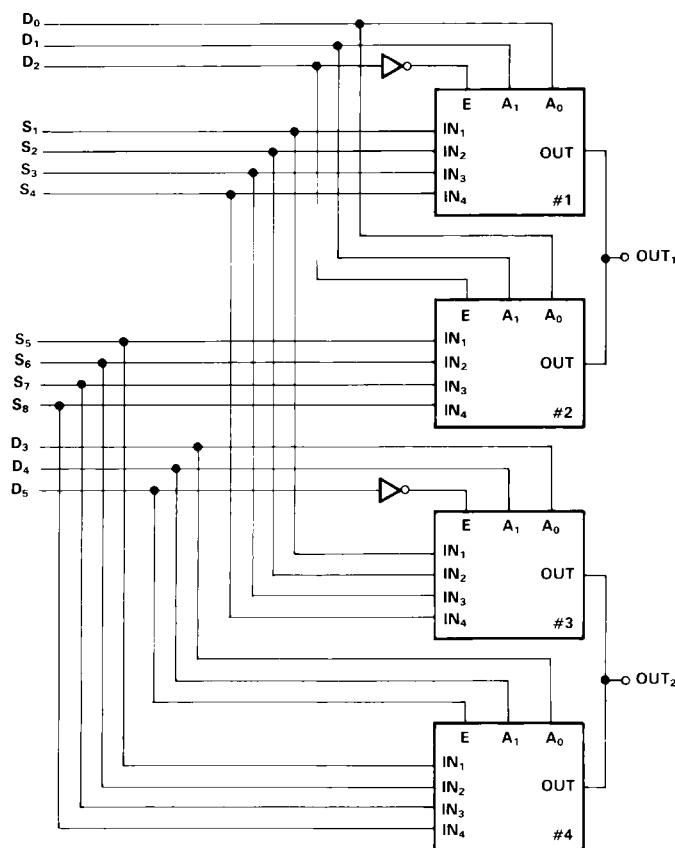

Figure 10. Enable to Channel "Off" Response

**CROSSPOINT CIRCUIT APPLICATIONS**

Four AD9300 multiplexers can be used to implement an 8 × 2 crosspoint, as shown in Figure 11. The circuit is modular in concept, with each pair of multiplexers (#1 and #2; #3 and #4) forming an 8 × 1 crosspoint. When the inputs to all four units are connected as shown, the result is an 8 × 2 crosspoint circuit.



8 X 2 SIGNAL CROSSPOINT USING FOUR AD9300 MULTIPLEXERS

Figure 11. 8 x 2 Signal Crosspoint Using Four AD9300 Multiplexers

The truth table describes the relationships among the digital inputs (D<sub>0</sub>–D<sub>5</sub>) and the analog inputs (S<sub>1</sub>–S<sub>8</sub>) and which signal input is selected at the outputs (OUT<sub>1</sub> and OUT<sub>2</sub>). The number of crosspoint modules that can be connected in parallel is limited by the drive capabilities of the input signal sources. High input impedance (3 MΩ) and low input capacitance (2 pF) of the AD9300 help minimize this limitation.

8 × 2 Crosspoint Truth Table

D <sub>2</sub> or D <sub>5</sub>	D <sub>1</sub> or D <sub>4</sub>	D <sub>0</sub> or D <sub>3</sub>	OUT <sub>1</sub> or OUT <sub>2</sub>
0	0	0	S <sub>1</sub>
0	0	1	S <sub>2</sub>
0	1	0	S <sub>3</sub>
0	1	1	S <sub>4</sub>
1	0	0	S <sub>5</sub>
1	0	1	S <sub>6</sub>
1	1	0	S <sub>7</sub>
1	1	1	S <sub>8</sub>

Adding to the number of inputs applied to each crosspoint module is simply a matter of adding AD9300 multiplexers in parallel to the module. Eight devices connected in parallel result in a 32 × 1 crosspoint, which can be used with input signals having 30 MHz bandwidth and 1 V peak-to-peak amplitude. Even more AD9300 units can be added if input signal amplitude and/or bandwidth are reduced; if they are not, distortion of the output signals can result.

When an AD9300 is enabled, its low output impedance causes the "off" isolation of disabled parallel devices to be greater than the crosstalk rejection of a single unit.

**OUTLINE DIMENSIONS**  
 Dimensions shown in inches and (mm).

**16-Pin Cerdip (Q) Package**

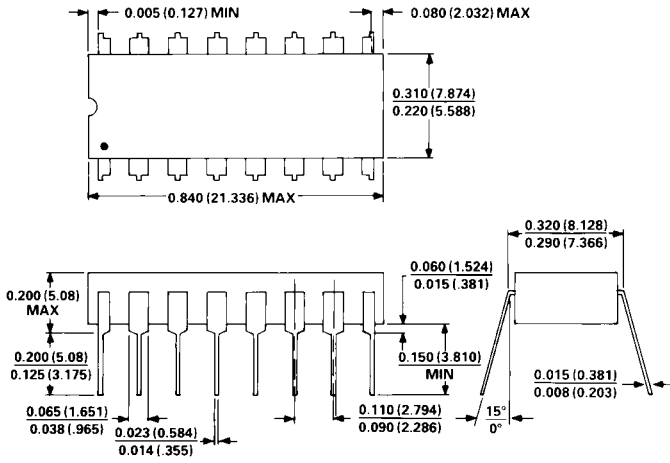

NOTES:  
 LEAD NO. 1 IDENTIFIED BY DOT OR NOTCH.  
 LEADS ARE SOLDER-DIPPED OR TIN-PLATED KOVAR OR ALLOY 42.

**20-Pin LCC (E) Package**

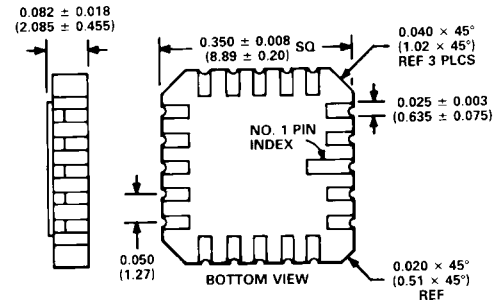

**20-Pin PLCC (P) Package**

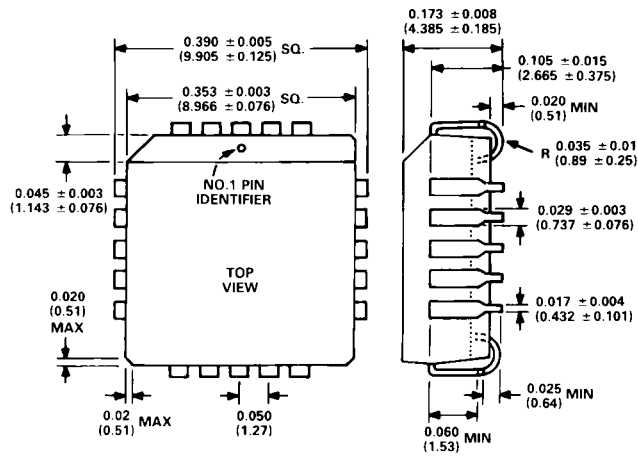

C-1184a-21-11/90

PRINTED IN U.S.A.