

### Features

- Operating voltage: 4.4V~5.5V
- Operating frequency:  $f_{SYS}=6M$
- Design for Windows 95/98/NT/2000/XP
- Phantom key detection
- Low voltage reset function
- USB and PS2 modes supported
- Auto detect USB or PS2 interface
- USB 1.1 low speed function
- Supports PS2 code set 1 and code set 2
- Supports multimedia key
- Supports ACPI key
- Supports mini-keyboard with Fn key
- Built-in Watchdog Timer
- HALT function and wake-up feature for USB mode to reduce power consumption
- 40-pin DIP package

### General Description

The HT82K629A can function both in USB and PS2 interface environment. For PS2 interface, it supports IBM PC/AT, IBM PS/2 and all compatible machines and provides a 16-character first-in-first-out buffer in which data

is stored. For USB interface, it can support the USB standard request as well as HID class request version 1.1.

### Block Diagram

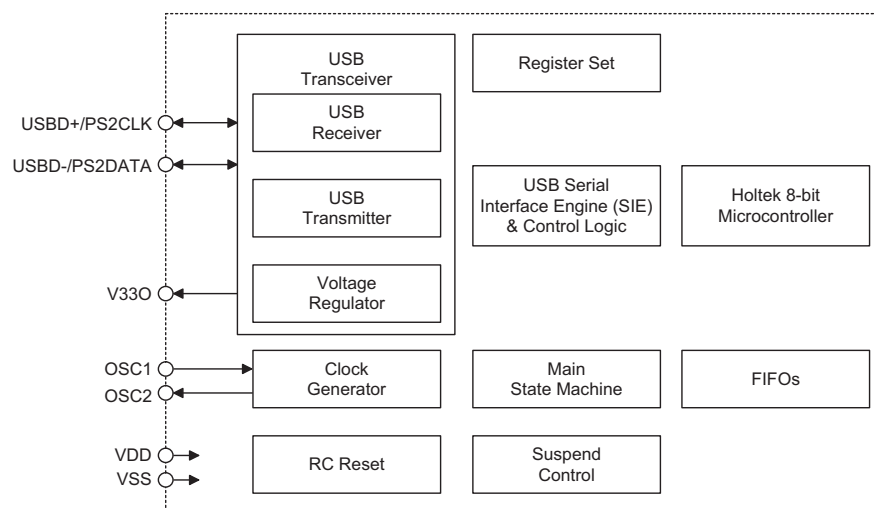

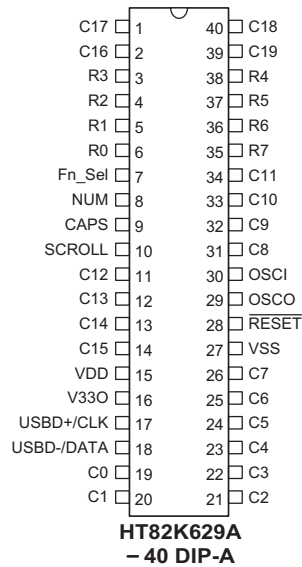
**Pin Assignment**

**Pin Description**

Pin No.	Pin Name	I/O	Description
1, 2, 11~14 19~26, 31~34 39, 40	C0~C19	O	Keyboard matrix scanning output pins
3~6, 35~38	R0~R7	I	Keyboard matrix scanning input pins
7	Fn_Sel	I	Mini-keyboard select, the function is enabled if connected to .
8	NUM	O	Num lock indicator
9	CAPS	O	Caps lock indicator
10	SCROLL	O	Scroll lock indicator
15	VDD	—	Positive power supply
16	V33O	—	3.3V regulator output
17	USBD+/CLK	I/O	USB- or PS2 CLK I/O line USB or PS2 function is controlled by software control register.
18	USB-/DATA	I/O	USB- or PS2 DATA I/O line USB or PS2 function is controlled by software control register.
27	VSS	—	Negative power supply, ground
28	RESET	I	Schmitt trigger input. Active low.
29	OSCO	O	OSCO, OSCI are connected to a 6MHz or 12MHz crystal/resonator for the internal system clock.
30	OSCI	I	

**Absolute Maximum Ratings**

Supply Voltage .....	$V_{SS}-0.3V$ to $V_{SS}+6.0V$	Storage Temperature .....	$-50^{\circ}C$ to $125^{\circ}C$
Input Voltage .....	$V_{SS}-0.3V$ to $V_{DD}+0.3V$	Operating Temperature .....	$0^{\circ}C$ to $70^{\circ}C$

Note: These are stress ratings only. Stresses exceeding the range specified under "Absolute Maximum Ratings" may cause substantial damage to the device. Functional operation of this device at other conditions beyond those listed in the specification is not implied and prolonged exposure to extreme conditions may affect device reliability.

**D.C. Characteristics**

Ta=25°C

Symbol	Parameter	Test Conditions		Min.	Typ.	Max.	Unit
		V <sub>DD</sub>	Conditions				
V <sub>DD</sub>	Operating Voltage	5V	—	4.4	—	5.5	V
f <sub>SYS</sub>	Operating Frequency	5V	f <sub>SYS</sub> =6MHz	5.9747	6	6.0258	MHz
I <sub>SB</sub>	Standby Current	5V	No load, system HALT	—	—	500	μA
I <sub>OP</sub>	Operating Current	5V	No load, f <sub>SYS</sub> =6MHz	—	—	12	mA
V <sub>V330</sub>	3.3V Regulator Output	5V	I <sub>V330</sub> =-5mA	3	3.3	3.6	V
R <sub>ph</sub>	Internal Pull-high Resistance (C0~C19, R0~R7)	5V	—	25	50	75	kΩ
V <sub>IL1</sub>	Input Low Voltage for I/O Ports	5V	—	0	—	0.8	V
V <sub>IH1</sub>	Input High Voltage for I/O Ports	5V	—	2	—	5	V
V <sub>IL2</sub>	Input Low Voltage ( $\overline{\text{RESET}}$ )	5V	—	0	—	0.4V <sub>DD</sub>	V
V <sub>IH2</sub>	Input High Voltage ( $\overline{\text{RESET}}$ )	5V	—	0.9V <sub>DD</sub>	—	V <sub>DD</sub>	V
I <sub>OL1</sub>	Sink Current (Fn_sel)	5V	V <sub>OL</sub> =0.4V	10	25	—	mA
I <sub>OL2</sub>	Sink Current (R0~R7)	5V	V <sub>OL</sub> =0.4V	5	10	—	mA
I <sub>OL3</sub>	Sink Current (C0~C19, NUM, CAPS, SCROLL)	5V	V <sub>OL</sub> =0.4V	2	4	—	mA
I <sub>OL4</sub>	Sink Current (C0~C19, NUM, CAPS, SCROLL)	5V	V <sub>OL</sub> =3.4V	12	17	—	mA
I <sub>OH1</sub>	Source Current (Fn_sel)	5V	V <sub>OH</sub> =3.4V	-8	-16	—	mA
I <sub>OH2</sub>	Source Current (C0~C19, R0~R7, NUM, CAPS, SCROLL)	5V	V <sub>OH</sub> =3.4V	-2	-5	—	mA

**A.C. Characteristics**

Ta=25°C

Symbol	Parameter	Test Conditions		Min.	Typ.	Max.	Unit
		V <sub>DD</sub>	Conditions				
f <sub>WDT</sub>	Built-in 32kHz RC OSC for Watchdog Timer	—	—	—	32	—	kHz

## Functional Description

### Command from the Host

The following table shows the commands that the host may send and their hexadecimal values.

Command	Hex Value
Set/Reset Status Indicators	ED
Echo	EE
Invalid Command	EF
Select Alternate Scan Codes	F0
Invalid Command	F1
Read ID	F2
Set Typematic Rate/Delay	F3
Enable	F4
Default Disable	F5
Set Default	F6
Set All Keys – Typematic	F7
Set All Keys – Make/Break	F8
Set All Keys – Make	F9
Set All Keys – Typematic/Make/Break	FA
Set Key Type – Typematic	FB
Set Key Type – Make/Break	FC
Set Key Type – Make	FD
Resend	FE
Reset	FF

The commands may be sent to the HT82K629A at any time and the HT82K629A will respond within 25ms except when performing the internal diagnostics or executing a Reset command.

### EDH – Set/Reset Status Indicators

Three status indicators on the keyboard-Num Lock, Caps Lock, and Scroll Lock-are accessible by the host. The HT82K629A activates or deactivates these indicators when it receives a valid command-code sequence from the system. The command sequence begins with the command byte (hex ED). The HT82K629A responds to the command byte with ACK, discontinues scanning, assignments for this option byte are as follow:

Bit	Indicator
0	Scroll Lock Indicator
1	Num Lock Indicator
2	Caps Lock Indicator
3~7	Reserved (Must be 0)

If a bit for an indicator is set to 1, the indicator is turned on. If a bit is set to 0, the indicator is turned off.

The HT82K629A responds to the option byte with ACK, sets the indicators and if the HT82K629A was previously enabled, continues scanning. The status of the indicators will reflect the bits in the option byte and can be activated or deactivated in any combination. If another command is received in place of the option byte, execution of the Set/Reset Mode Indicators command is stopped, with no change to the indicator status, and the new command is processed.

Immediately after power-on, the lights default to the off state. If the Set Default and Default Disable commands are received, the lamps remain in the state they were in before the command was received.

### EEH – Echo

Echo is a diagnostic aid. When the HT82K629A receives this command, it issues a hex EE response and if the HT82K629A was previously enabled, continues scanning.

### EFH and F1H – Invalid Command

EFH and F1H are invalid commands and are not supported. If HT82K629A receives one of these and sends it, the HT82K629A will not acknowledge the command, but returns a Resend command and continues in its previous scanning state.

### F0H – Select Alternate Scan Codes

This command instructs the HT82K629A to select one of the two sets of scan codes. The HT82K629A acknowledges receipt of this command with ACK, clears both the output buffer and the typematic key. The host then sends the option byte and the keyboard responds with another ACK. An option byte value of hex 01 selects scan code set 1, hex 02 selects set 2.

An option byte value of hex 00 causes the HT82K629A to acknowledge with ACK and sends a byte telling the host which scan code set is currently in use.

After establishing the new scan code set, the HT82K629A returns to the scanning state it was in before receiving the Select Alternate Scan Codes command.

### F2H – Read ID

This command requests identification information from the HT82K629A. The HT82K629A responds with , discontinues scanning and sends the two keyboard ID bytes hex 83h and ABh. After the output of the second ID byte, the HT82K629A resumes scanning.

**F3H – Set Typematic Rate/Delay**

The host issues the Set Typematic Rate/Delay command to change the typematic rate and delay. The HT82K629A responds to the command with ACK, stops scanning and waits for the system to issue the rate/delay value byte. The HT82K629A responds to the value byte with another ACK, sets the rate and delay to the value indicated, and continues scanning (if it was previously enabled). Bits 6 and 5 indicate the delay, and bits 4, 3, 2, 1 and 0 indicate the rate. Bit7 is always 0. The delay is equal to 1 plus the binary value bit 6 and 5, multiplied by 250ms±20%.

The period (interval from one typematic output to the next) is determined by the following equation:

$$\text{Period} = (8+A) \cdot (2^B) \cdot 0.00417 \text{ seconds.}$$

Where:

A = binary value of bits 2, 1, and 0.

B = binary value of bits 4, and 3.

The typematic rate is 1 for each period and are listed as follows:

Bit	Typematic Rate ± 20%	Bit	Typematic Rate ± 20%
00000	30.0	10000	7.5
00001	26.7	10001	6.7
00010	24.0	10010	6.0
00011	21.8	10011	5.5
00100	20.0	10100	5.0
00101	18.5	10101	4.6
00110	17.1	10110	4.3
00111	16.0	10111	4.0
01000	15.0	11000	3.7
01001	13.3	11001	3.3
01010	12.0	11010	3.0
01011	10.9	11011	2.7
01100	10.0	11100	2.5
01101	9.2	11101	2.3
01110	8.0	11110	2.1
01111	8.0	11111	2.0

The default values for the HT82K629A are as follows:

Typematic rate= 10.9 characters per second ± 20%

Delay = 500ms±20%

The execution of this command stops without changes to the existing rate if another command is received instead of the rate/delay value byte.

**F4H – Enable**

Upon receipt of this command, the HT82K629A will respond with ACK, clears its output buffer, clears the last typematic key, and starts scanning.

**F5H – Default Disable**

The Default Disable command resets all conditions to the power on default states. The HT82K629A will respond with ACK, clears its output buffer, sets the default typematic rate/delay, and clears the last typematic key. The HT82K629A then stops scanning and awaits further command.

**F6H – Set Default**

The Set Default command resets all conditions to the power on default states. The HT82K629A will respond with ACK, clears its output buffer, sets the default key typematic rate/delay, and clears the last typematic key then continues scanning.

**F7H, F8H, F9H, FAH – Set All Keys**

Since HT82K629A do not support keyboard code set 3 format, so it will not acknowledge the command but returns a Resend command and continues in its previous scanning state.

**FBH, FCH, FDH – Set Key Type**

Since HT82K629A do not support keyboard code set 3 format, so it will not acknowledge the command but returns a Resend command and continues in its previous scanning state.

**FEH – Resend**

The host sends this command when it detects an error in any transmission from the HT82K629A. It is sent only after a data transmission and before the host allows the next data output. When a Resend is received, the HT82K629A sends the previous output again (unless the previous output was Resent, in which case the HT82K629A sends the last byte before the Resend command).

**Commands to the Host**

The following table shows the commands that the HT82K629A may send to the host and their hexadecimal values.

Command	Hex Value
Key Detection Error/Overrun	00 (Code Set 2)
Keyboard ID	83AB
Bat Completion Code	AA
Bat Failure Core	FC
Echo	EE
Acknowledge	FA
Resend	FE
Key Detection Error/Overrun	FF (Code Set 1)

**00H or FFH – Key Detection Error**

The HT82K629A sends a key detection error character if conditions in the keyboard make it impossible to identify a switch closure. If the HT82K629A is using scan code set 1, the code is FFH. For sets 2, the code is 00H.

**00H or FFH – Overrun**

An overrun character is placed in the HT82K629A buffer and replaces the last code when the buffer capacity has been exceeded. The code is sent to the host when it reaches the top of the buffer queue. If the HT82K629A is using scan code set 1, the code is FFH. For sets 2, the code is 00H.

**83AbH – Keyboard ID**

The keyboard ID consists of 2 bytes, Hex 83AbH. The HT82K629A responds to the Read ID with ACK, discontinues scanning and sends 2 ID bytes. The low byte is sent first followed by the high byte. Following the output of Keyboard ID, the HT82K629A begins scanning.

**EEH – Echo**

The HT82K629A sends this code in response to an Echo command.

**AAH – BAT Completion Code**

Following a satisfactory completion of the BAT, the HT82K629A sends AAH. Any other code indicates keyboard failure.

**FCH – BAT Failure Code**

If a BAT failure occurs, the HT82K629A sends this code, discontinues scanning and waits for a host response or reset.

**FEH – Resend**

The HT82K629A issues a Resend command following receipt of an invalid input or any input with incorrect parity. If the host sends nothing to the HT82K629A, no response is required.

**Data Communications**

- Data output
    - ♦ If CLK=0, no transmission (keyboard is inhibited).
    - ♦ If CLK=1, DATA=0, no transmission (system request to send).
    - ♦ If CLK=1, DATA=1, transmission permitted.
    - ♦ Data will be valid before the trailing edge and beyond the leading edge of the clock.
    - ♦ The KB checks the clock line for an active level every 60ms.
    - ♦ If line contention occurs (system brings the clock low before the tenth clock), set clock=data=high.
  - Data input
    - ♦ The system overrides the clock line for at least 60ms.
    - ♦ The keyboard checks the clock line state at intervals of 10ms.
    - ♦ If a system request-to-send is detected, the keyboard counts 11 data bits.
    - ♦ Data will be valid before the rising edge and beyond the falling edge.
    - ♦ After the 10th bit, the keyboard checks for an active level on the "data" line. If the line is active it is forced to be inactive, and counts one more bits.
- Note: This action signals the system that the keyboard has received its data. Upon reception of this signal, the system returns to the ready state, in which it can accept keyboard outputs or goes to the inhibit state until it is ready.

If the keyboard "data" line is found to be at an inactive level following the 10th bit, a frame error has occurred, and the keyboard continues to count until the "data" line becomes active. The keyboard then makes the "data" line inactive and sends a Resend.

**Data Stream**

Mode 1,2,3	
B1	Start bit (always 0)
B2	Data bit 0
B3	Data bit 1
B4	Data bit 2
B5	Data bit 3
B6	Data bit 4
B7	Data bit 5
B8	Data bit 6
B9	Data bit 7
B10	Parity bit (odd par)
B11	Stop bit (always 1)

Note: The parity bit is either 1 or 0, and the 8 data bits, plus the parity bit, always have an odd number of 1µs.

**Key Code Set 1**

Key Number and Symbol			Make/Break Code	Key Number and Symbol		Make/Break Code
1	~	'	29/A9	47	X	2D/AD
2	!	1	02/82	48	C	2E/AE
3	@	2	03/83	49	V	2F/AF
4	#	3	04/84	50	B	30/B0
5	\$	4	05/85	51	N	31/B1
6	%	5	06/86	52	M	32/B2
7	^	6	07/87	53	<   ,	33/B3
8	&	7	08/88	54	>   .	34/B4
9	*	8	09/89	55	?   /	35/B5
10	(	9	0A/8A	57	Shift (R)	36/B6
11	)	0	0B/8B	58	Ctrl (L)	1D/9D
12	_	-	0C/8C	60	Alt (L)	38/B8
13	+	=	0D/8D	61	Space	39/B9
14	Keycode14 (*J)		7D/FD	62	Alt (R)	E0 38/E0 B8
15	Back Space		0E/8E	64	Ctrl (R)	E0 1D/E0 9D
16	Tab		0F/8F	90	Num Lock	45/C5
17	Q		10/90	91	7   Home	47/C7
18	W		11/91	92	4   ←	4B/CB
19	E		12/92	93	1   End	4F/CF
20	R		13/93	96	8   ↑	48/C8
21	T		14/94	97	5	4C/CC
22	Y		15/95	98	2   ↓	50/D0
23	U		16/96	99	0   Ins	52/D2
24	I		17/97	100	*	37/B7
25	O		18/98	101	9   PgUp	49/C9
26	P		19/99	102	6   →	4D/CD
27	{   [		1A/9A	103	3   PgDn	51/D1
28	}   ]		1B/9B	104	.   Del	53/D3
29	Keycode29 (*4)		2B/AB	105	-	4A/CA
30	Caps Lock		3A/BA	106	+	4E/CE
31	A		1E/9E	107	Keycode107 (*B)	7E/FE
32	S		1F/9F	108	Enter_R	E0 1C/E0 9C
33	D		20/A0	110	ESC	01/81
34	F		21/A1	112	F1	3B/BB
35	G		22/A2	113	F2	3C/BC
36	H		23/A3	114	F3	3D/BD
37	J		24/A4	115	F4	3E/BE
38	K		25/A5	116	F5	3F/BF
39	L		26/A6	117	F6	40/C0
40	:	;	27/A7	118	F7	41/C1
41	"	'	28/A8	119	F8	42/C2

Key Number and Symbol		Make/Break Code	Key Number and Symbol		Make/Break Code
42	Keycode42 (*5BJ)	2B/AB	120	F9	43/C3
43	Enter_L	1C/9C	121	F10	44/C4
44	Shift (L)	2A/AA	122	F11	57/D7
45	Keycode45 (*5B)	56/D6	123	F12	58/D8
46	Z	2C/AC	125	Scroll Lock	46/C6

Key Number and Symbol	Base Case Shift+Num	Left-Shift	Right-Shift	Num Lock
75	Insert /E0 D2	E0 AA E0 52 /E0 D2 E0 2A	E0 B6 E0 52 /E0 D2 E0 36	E0 2A E0 52 /E0 D2 E0 AA
76	Delete /E0 D3	E0 AA E0 53 /E0 D3 E0 2A	E0 B6 E0 53 /E0 D3 E0 36	E0 2A E0 53 /E0 D3 E0 AA
79	← /E0 CB	E0 AA E0 4B /E0 CB E0 2A	E0 B6 E0 4B /E0 CB E0 36	E0 2A E0 4B /E0 CB E0 AA
80	Home E0 47 /E0 C7	E0 AA E0 47 /E0 C7 E0 2A	E0 B6 E0 47 /E0 C7 E0 36	E0 2A E0 47 /E0 C7 E0 AA
81	End E0 4F /E0 CF	E0 AA E0 4F /E0 CF E0 2A	E0 B6 E0 4F /E0 CF E0 36	E0 2A E0 4F /E0 CF E0 AA
83	↑ E0 48 /E0 C8	E0 AA E0 48 /E0 C8 E0 2A	E0 B6 E0 48 /E0 C8 E0 36	E0 2A E0 48 /E0 C8 E0 AA
84	↓ E0 50 /E0 D0	E0 AA E0 50 /E0 D0 E0 2A	E0 B6 E0 50 /E0 D0 E0 36	E0 2A E0 50 /E0 D0 E0 AA
85	PgUp E0 49 /E0 C9	E0 AA E0 49 /E0 C9 E0 2A	E0 B6 E0 49 /E0 C9 E0 36	E0 2A E0 49 /E0 C9 E0 AA
86	PgDn E0 51 /E0 D1	E0 AA E0 51 /E0 D1 E0 2A	E0 B6 E0 51 /E0 D1 E0 36	E0 2A E0 51 /E0 D1 E0 AA
89	→ E0 4D /E0 CD	E0 AA E0 4D /E0 CD E0 2A	E0 B6 E0 4D /E0 CD E0 36	E0 2A E0 4D /E0 CD E0 AA
When both shift keys are held down: key number 75		Both Shift E0 AA E0 B6 E0 52/E0 D2 E0 2A E0 36		

Key Number and Symbol	Base	Left-Shift	Right-Shift
95	/	E0 AA E0 35/E0 B5 E0 2A	E0 B6 E0 35/E0 B5 E0 36
When both shift keys are held down: key number 95		Both Shift E0 AA E0 B6 E0 35/E0 B5 E0 2A E0 36	

Key Number and Symbol	Base	Shift/Ctrl	Alt
124	Print Screen	E0 37/E0 B7	54/D4

Key Number and Symbol	Base	Ctrl
126	Pause	E0 46 E0 C6
This key is not typematic, all associated scan codes occur on the make code.		

Key Number and Function	Make/Break Code	Default
56 (*BJ)	Brazil BA0	73/F3
131 (*J)	Japanese J131	7B/FB
132 (*J)	Japanese J132	79/F9
133 (*J)	Japanese J133	70/F0
150	Korea KC-L	F1/-
151	Korea KC-R	F0/-



Key Number and Function		Make/Break Code	Default
ACPI	Power	E0 5E/E0 DE	Make/Break
ACPI	Sleep	E0 5F/E0 DF	Make/Break
ACPI	Wake-up	E0 63/E0 E3	Make/Break
Windows Key	L Win	E0 5B	Make/Break/Typematic
		/E0 DB	
Windows Key	R Win	E0 5C	Make/Break/Typematic
		/E0 DC	
Windows Key	APP	E0 5D	Make/Break/Typematic
		/E0 DD	
Multimedia Key	E-Mail	E0 6C/E0 EC	Make/Break
Multimedia Key	WWW Home	E0 32/E0 B2	Make/Break
Multimedia Key	WWW Favorites	E0 66/E0 E6	Make/Break
Multimedia Key	WWW Search	E065/E0 E5	Make/Break
Multimedia Key	WWW Refresh	E0 67/E0 E7	Make/Break
Multimedia Key	WWW Stop	E0 68/E0 E8	Make/Break
Multimedia Key	WWW Forward	E0 69/E0 E9	Make/Break
Multimedia Key	WWW Back	E0 6A/E0 EA	Make/Break
Multimedia Key	Media	E0 6D/E0 ED	Make/Break
Multimedia Key	Play/Pause	E0 22/E0 A2	Make/Break
Multimedia Key	Stop	E0 24/E0 A4	Make/Break
Multimedia Key	Prev Track	E0 10/E0 90	Make/Break
Multimedia Key	Next Track	E0 19/E0 99	Make/Break
Multimedia Key	Volume+	E0 30/E0 B0	Make/Break/Typematic
Multimedia Key	Volume-	E0 2E/E0 AE	Make/Break/Typematic
Multimedia Key	Mute	E0 20/E0 A0	Make/Break
Multimedia Key	My Computer	E0 6B/E0 EB	Make/Break
Multimedia Key	Calculator	E0 21/E0 A1	Make/Break
Multimedia Key	Screen save	E0 26/E0 A6	Make/Break
Multimedia Key	Rec	E0 1E/E0 9E	Make/Break
Multimedia Key	Rew	E0 17/E0 97	Make/Break
Multimedia Key	Minimize	E0 2D/E0 AD	Make/Break
Multimedia Key	Eject	E0 11/E0 91	Make/Break
* 4 – 104 Keyboard Only * 5 – 105 Keyboard Only		*B – 107 Keyboard Only *J – 109 Keyboard Only	

**Key Code Set 2**

Key Number and Symbol			Make/Break Code	Key Number and Symbol		Make/Break Code
1	~	'	0E/F0 0E	47	X	22/F0 22
2	!	1	16/F0 16	48	C	21/F0 21
3	@	2	1E/F0 1E	49	V	2A/F0 2A
4	#	3	26/F0 26	50	B	32/F0 32
5	\$	4	25/F0 25	51	N	31/F0 31
6	%	5	2E/F0 2E	52	M	3A/F0 3A
7	^	6	36/F0 36	53	<   ,	41/F0 41
8	&	7	3D/F0 3D	54	>   .	49/F0 49
9	*	8	3E/F0 3E	55	?   /	4A/F0 4A
10	(	9	46/F0 46	57	Shift (R)	59/F0 59
11	)	0	45/F0 45	58	Ctrl (L)	14/F0 14
12	_	-	4E/F0 4E	60	Alt (L)	11/F0 11
13	+	=	55/F0 55	61	Space	29/F0 29
14	Keycode14 (*J)		6A/F0 6A	62	Alt (R)	E0 11/E0 F0 11
15	Back Space		66/F0 66	64	Ctrl (R)	E0 14/E0 E0 F0 14
16	Tab		0D/F0 0D	90	Num Lock	77/F0 77
17	Q		15/F0 15	91	7   Home	6C/F0 6C
18	W		1D/F0 1D	92	4   ←	6B/F0 6B
19	E		24/F0 24	93	1   End	69/F0 69
20	R		2D/F0 2D	96	8   ↑	75/F0 75
21	T		2C/F0 2C	97	5	73/F0 73
22	Y		35/F0 35	98	2   ↓	72/F0 72
23	U		3C/F0 3C	99	0   Ins	70/F0 70
24	I		43/F0 43	100	*	7C/F0 7C
25	O		44/F0 44	101	9   PgUp	7D/F0 7D
26	P		4D/F0 4D	102	6   →	74/ F0 74
27	{   [		54/F0 54	103	3   PgDn	7A/ F0 7A
28	}   ]		5B/F0 5B	104	.   Del	71/F0 71
29	Keycode29 (*4)		5D/F0 5D	105	-	7B/F0 7B
30	Caps Lock		58/F0 58	106	+	79/F0 79
31	A		1C/F0 1C	107	Keycode107 (*B)	6D/F0 6D
32	S		1B/F0 1B	108	Enter_R	E0 5A/E0 F0 5A
33	D		23/F0 23	110	ESC	76/F0 76
34	F		2B/F0 2B	112	F1	05/F0 05
35	G		34/F0 34	113	F2	06/F0 06
36	H		33/F0 33	114	F3	04/F0 04
37	J		3B/F0 3B	115	F4	0C/F0 0C
38	K		42/F0 42	116	F5	03/F0 03
39	L		4B/F0 4B	117	F6	0B F0 0B
40	:	;	4C/F0 4C	118	F7	83/F0 83
41	"	'	52/F0 52	119	F8	0A/F0 0A

Key Number and Symbol		Make/Break Code	Key Number and Symbol		Make/Break Code
42	Keycode42 (*5BJ)	5D/F0 5D	120	F9	01/F0 01
43	Enter_L	5A/F0 5A	121	F10	09/F0 09
44	Shift (L)	12/F0 12	122	F11	78/F0 78
45	Keycode45 (*5B)	61/F0 61	123	F12	07/F0 07
46	Z	1A/F0 1A	125	Scroll Lock	7E/F0 7E

Key Number and Symbol	Base Case Shift+Num	Left-Shift	Right-Shift	Num Lock	
75	Insert E0 70 /E0 F0 70	E0 F0 12 E0 70 /E0 F0 70 E0 12	E0 F0 59 E0 70 /E0 F0 70 E0 59	E0 12 E0 70 /E0 F0 70 E0 F0 12	
76	Delete E0 71 /E0 F0 71	E0 F0 12 E0 71 /E0 F0 71 E0 12	E0 F0 59 E0 71 /E0 F0 71 E0 59	E0 12 E0 71 /E0 F0 71 E0 F0 12	
79	← E0 6B /E0 F0 6B	E0 F0 12 E0 6B /E0 F0 6B E0 12	E0 F0 59 E0 6B /E0 F0 6B E0 59	E0 12 E0 6B /E0 F0 6B E0 F0 12	
80	Home E0 6C /E0 F0 6C	E0 F0 12 E0 6C /E0 F0 6C E0 12	E0 F0 59 E0 6C /E0 F0 6C E0 59	E0 12 E0 6C /E0 F0 6C E0 F0 12	
81	End E0 69 /E0 F0 69	E0 F0 12 E0 69 /E0 F0 69 E0 12	E0 F0 59 E0 69 /E0 F0 69 E0 59	E0 12 E0 69 /E0 F0 69 E0 F0 12	
83	↑ E0 75 /E0 F0 75	E0 F0 12 E0 75 /E0 F0 75 E0 12	E0 F0 59 E0 75 /E0 F0 75 E0 59	E0 12 E0 75 /E0 F0 75 E0 F0 12	
84	↓ E0 72 /E0 F0 72	E0 F0 12 E0 72 /E0 F0 72 E0 12	E0 F0 59 E0 72 /E0 F0 72 E0 59	E0 12 E0 72 /E0 F0 72 E0 F0 12	
85	PgUp E0 7D /E0 F0 7D	E0 F0 12 E0 7D /E0 F0 7D E0 12	E0 F0 59 E0 7D /E0 F0 7D E0 59	E0 12 E0 7D /E0 F0 7D E0 F0 12	
86	PgDn E0 7A /E0 F0 7A	E0 F0 12 E0 7A /E0 F0 7A E0 12	E0 F0 59 E0 7A /E0 F0 7A E0 59	E0 12 E0 7A /E0 F0 7A E0 F0 12	
89	→ E0 74 /E0 F0 74	E0 F0 12 E0 74 /E0 F0 74 E0 12	E0 F0 59 E0 74 /E0 F0 74 E0 59	E0 12 E0 74 /E0 F0 74 E0 F0 12	
When both Shift keys are held down: key number 75		Both Shift E0 AA E0 B6 E0 52/E0 D2 E0 2A E0 36			

Key Number and Symbol	Base	Left-Shift	Right-Shift
95	/ E0 4A/E0 F0 4A	E0 F0 12 E0 4A/E0 F0 4A E0 12	E0 F0 59 E0 4A/E0 F0 4A E0 59
When both Shift keys are held down: key number 95		Both Shift E0 F0 12 E0 F0 59 E0 4A/E0 F0 4A E0 12 E0 59	

Key Number and Symbol	Base	Shift/Ctrl	Alt
124	Print Screen E0 12 E0 7C/E0 F0 7C E0 F0 12	E0 7C/E0 F0 7C	84/F0 84

Key Number and Symbol	Base	Ctrl
126	Pause E1 14 77 E1 F0 14 F0 77	E0 7E E0 F0 7E
This key is not typematic, all associated scan codes occur on the make code.		

Key Number and Function	Make/Break code	Default
56 (*BJ)	Brazil BA0 51/F0 51	Make/Break/Typematic
131 (*J)	Japanese J131 67/F0 67	Make/Break/Typematic
132 (*J)	Japanese J132 64/F0 64	Make/Break/Typematic
133 (*J)	Japanese J133 13/F0 13	Make/Break/Typematic
150	Korea KC-L F1/-	Make
151	Korea KC-R F2/-	Make

Key Number and Function		Make/Break code	Default
ACPI	Power	E0 37/E0 F0 37	Make/Break
ACPI	Sleep	E0 3F/E0 F0 3F	Make/Break
ACPI	Wake-up	E0 5E/E0 F0 5E	Make/Break
Windows Key	L Win	E0 1F	Make/Break/Typematic
		/E0 F0 1F	
Windows Key	R Win	E0 27	Make/Break/Typematic
		/E0 F0 27	
Windows Key	APP	E0 2F	Make/Break/Typematic
		/E0 F0 2F	
Multimedia Key	E-Mail	E0 48/E0 F0 48	Make/Break
Multimedia Key	WWW Home	E0 3A/E0 F0 3A	Make/Break
Multimedia Key	WWW Favorites	E0 18/E0 F0 18	Make/Break
Multimedia Key	WWW Search	E0 10/E0 F0 10	Make/Break
Multimedia Key	WWW Refresh	E0 20/E0 F0 20	Make/Break
Multimedia Key	WWW Stop	E0 28/E0 F0 28	Make/Break
Multimedia Key	WWW Forward	E0 30/E0 F0 30	Make/Break
Multimedia Key	WWW Back	E0 38/E0 F0 38	Make/Break
Multimedia Key	Media	E0 50/E0 F0 50	Make/Break
Multimedia Key	Play/Pause	E0 34/E0 F0 34	Make/Break
Multimedia Key	Stop	E0 3B/E0 F0 3B	Make/Break
Multimedia Key	Prev Track	E0 15/E0 F0 15	Make/Break
Multimedia Key	Next Track	E0 4D/E0 F0 4D	Make/Break
Multimedia Key	Volume+	E0 32/E0 F0 32	Make/Break/Typematic
Multimedia Key	Volume-	E0 21/E0 F0 21	Make/Break/Typematic
Multimedia Key	Mute	E0 23/E0 F0 23	Make/Break
Multimedia Key	My Computer	E0 40/E0 F0 40	Make/Break
Multimedia Key	Calculator	E0 2B/E0 F0 2B	Make/Break
Multimedia Key	Screen save	E0 4B/E0 F0 4B	Make/Break
Multimedia Key	Rec	E0 1C/E0 F0 1C	Make/Break
Multimedia Key	Rew	E0 43/E0 F0 43	Make/Break
Multimedia Key	Minimize	E0 22/E0 F0 22	Make/Break
Multimedia Key	Eject	E0 1D/E0 F0 1D	Make/Break
* 4 – 104 Keyboard Only * 5 – 105 Keyboard Only		*B – 107 Keyboard Only *J – 109 Keyboard Only	

**Timing Diagrams**

**Data Output**

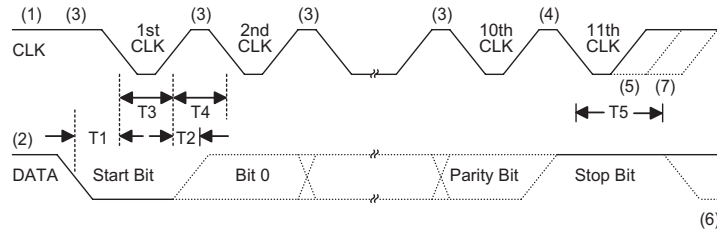

Timing Parameter	Min/Max
T1 DATA transition to the falling edge of CLK	5/25 $\mu$ sec
T2 Rising edge of CLK to DATA transition	5/T4-5 $\mu$ sec
T3 Duration of CLK inactive	30/50 $\mu$ sec
T4 Duration of CLK active	30/50 $\mu$ sec
T5 Time to auxiliary device inhibit after clock 11 to ensure that the auxiliary device does not start another transmission.	>0/50 $\mu$ sec

**Keyboard Data Input**

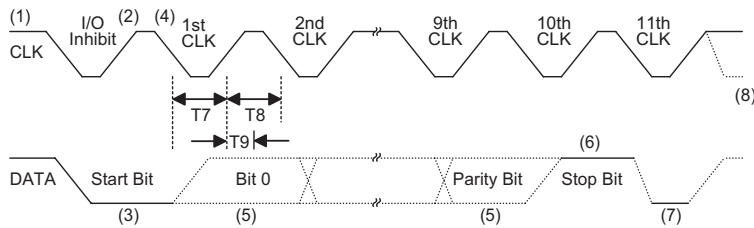

Timing Parameter	Min/Max
T7 Duration of CLK inactive	30/50 $\mu$ sec
T8 Duration of CLK active	30/50 $\mu$ sec
T9 Time from inactive to active CLK transition, used to time when the auxiliary device samples DATA	5/25 $\mu$ sec

**USB Interface**

HT82K629A has one control pipe for USB configuration, command and status type communication flows between clients software (BIOS, Win 98, Win 2K, Win ME and Win XP etc.) and HT82K629A keyboard encoder device. It also has two interrupt pipes to send the HID page 7 Standard keyboard code and ACPI, multimedia key correspondingly to clients software. For LED output, it comes from the control pipe.

HT82K629A can support USB standard request and HID class request. It is shown in the following table:

Item	Command	Description	Support	
USB1.1 Standard Request	Get_Status	USB get endpoints status such as STALL, wake-up, power information	Yes	
	Clear Feature	USB clear device STALL, or remote wake-up function.	Yes	
	Set Feature	USB set device STALL, or remote wake-up function.	Yes	
	Set Address	USB set device address	Yes	
	Get_Descriptor		USB get HT82K629A device, configuration information	Yes
			USB get HT82K629A string descriptor (option command)	No, response STALL
	Set_Descriptor		USB set device descriptor data (option command)	No, response STALL
	Get_Configuration		USB get device, configuration value	Yes (default 0 value)
	Set_Configuration		USB set device, configuration value	Yes
	Get_Interface		USB get device, interface	No, response STALL
	Set_Interface		USB set device, interface	No, response STALL
SYNCH_Frame		USB output frame number	No, response STALL	
HID1.1 Class Request	Get_Descriptor	USB get HT82K629A HID, report information	Yes	
	Set_Descriptor	USB set device descriptor data (option command)	No, response STALL	
	Get_Report	USB get keyboard, ACPI, multimedia data	Yes	
	Set_Report	Set keyboard LED	Yes	
	Get_Protocol	USB get boot or report protocol for endpoint	Yes (default report protocol)	
	Set_Protocol	USB set boot or report protocol for endpoint	Yes	
	Get_Idle	USB set keyboard idle rate	Yes (default 500ms)	
	Set_Idle	USB get keyboard idle rate	Yes	

**Keyboard Output Format for USB Interface**

- Endpoint1 – standard keyboard endpoint

The Endpoint1 of HT82K629A is used to send standard keyboard key code and is configured as interrupt pipe. It contain 8 bytes data. The first byte is a modified byte to send the left and right of the (Shift, ALT, CTRL and WIN) key status. It is in bitmap format. The second byte is a reserved byte. The third to eight bytes are used to send the other HID page7 key codes (except for the above modified key). The key code list is shown as the USB HID standard keyboard code table.

Bit 7	Bit 6	Bit 5	Bit 4	Bit 3	Bit 2	Bit 1	Bit 0
R_Win	R_ALT	R_Shift	R_Ctrl	L_Win	L_ALT	L_Shift	L_Ctrl
1: Key is pressed 0: Key is released							

**The Modified Byte Definition**

- Endpoint2 – ACPI, multimedia key endpoint

The Endpoint2 of the HT82K629A is used to send ACPI and multimedia key and is configured as interrupt pipe. For ACPI, there are two bytes data, the first byte is report ID byte = 01H, the second is ACPI key status.

Byte No.	Bit 7	Bit6	Bit 5	Bit 4	Bit 3	Bit 2	Bit 1	Bit 0
1	00000001b							
2	00000b					Wake-up	Sleep	Power
1: Key is pressed 0: Key is released								

**The ACPI Key Byte Definition**

For multimedia keys, there are four bytes data, the first byte is report ID byte = 02H, The second to fourth is the multimedia key status.

Byte No.	Bit 7	Bit6	Bit 5	Bit 4	Bit 3	Bit 2	Bit 1	Bit 0
1	00000010b							
2	Eject	CD Stop	Prev. Track	Next Track	Play/Pause	Mute	Volume-	Volume+
3	Refresh	WWW Stop	WWW Forward	WWW Back	WWW Home	WWW Favorites	WWW Search	E-Mail
4	Rewind	Record	Minimize	My Computer	Screen Save	Calculator	Explorer	Media
1: Key is pressed 0: Key is released								

**The Multimedia Key Bytes Definition**

- USB LED output

Client Software Output one byte LED data to HT82K629A, to control the LED status, through Endpoint0. The format is shown in the following table:

Bit 7	Bit 6	Bit 5	Bit 4	Bit 3	Bit 2	Bit 1	Bit 0
00000b					Scroll Lock	Cap Lock	Num Lock
1: LED on 0: LED off							

**USB HID Standard Keyboard Code Table**

Key Number and Symbol	HID Page	HID Code	Key Number and Symbol	HID Page	HID Code
1 ~ `	07	35	54 > .	07	37
2 ! 1	07	1E	55 ? /	07	38
3 @ 2	07	1F	56 Keycode56 (*BJ)	07	87
4 # 3	07	20	57 Shift (R)	07	E5
5 \$ 4	07	21	58 Ctrl (L)	07	E0
6 % 5	07	22	60 Alt (L)	07	E2
7 ^ 6	07	23	61 Ctrl (L)	07	2C
8 & 7	07	24	62 Alt (R)	07	E6
9 * 8	07	25	64 Ctrl (R)	07	E4
10 ( 9	07	26	75 Insert	07	49
11 ) 0	07	27	76 Delete	07	4C
12 _ -	07	2D	79 Left Arrow	07	50
13 + =	07	2E	80 Home	07	4A

Key Number and Symbol		HID Page	HID Code	Key Number and Symbol		HID Page	HID Code		
14	Keycode14 (*J)	07	89	81	End	07	4D		
15	Back Space	07	2A	83	↑	07	52		
16	Tab	07	2B	84	↓	07	51		
17	Q	07	14	85	PgUp	07	4B		
18	W	07	1A	86	PgDn	07	4E		
19	E	07	08	89	→	07	4F		
20	R	07	15	90	Num Lock	07	53		
21	T	07	17	91	7	Home	07	5F	
22	Y	07	1C	92	4	←	07	5C	
23	U	07	18	93	1	End	07	59	
24	I	07	0C	95	/		07	54	
25	O	07	12	96	8	↑	07	60	
26	P	07	13	97	5		07	5D	
27	{	[	07	2F	98	2	↓	07	5A
28	}	]	07	30	99	0	Ins	07	62
29	Keycode29 (*4)	07	31	100	*		07	55	
30	Caps Lock	07	39	101	9	PgUp	07	61	
31	A	07	04	102	6	→	07	5E	
32	S	07	16	103	3	PgDn	07	5B	
33	D	07	07	104	.	Del	07	63	
34	F	07	09	105	-		07	56	
35	G	07	0A	106	+		07	57	
36	H	07	0B	107	Keycode107 (*B)		07	85	
37	J	07	0D	108	Enter_R		07	58	
38	K	07	0E	110	ESC		07	29	
39	L	07	0F	112	F1		07	3A	
40	:	;	07	33	113	F2	07	3B	
41	"	'	07	34	114	F3	07	3C	
42	Keycode42 (*5BJ)	07	32	115	F4		07	3D	
43	Enter_L	07	28	116	F5		07	3E	
44	Shift (L)	07	E1	117	F6		07	3F	
45	Keycode45 (*5B)	07	64	118	F7		07	40	
46	Z	07	1D	119	F8		07	41	
47	X	07	1B	120	F9		07	42	
48	C	07	06	121	F10		07	43	
49	V	07	19	122	F11		07	44	
50	B	07	05	123	F12		07	45	
51	N	07	11	124	Print Screen		07	46	
52	M	07	10	125	Scroll Lock		07	47	
53	<	,	07	36	126	Pause	07	48	



Key Number and Symbol	HID Page	HID Code	Key Number and Symbol	HID Page	HID Code
* 4 – 104 Keyboard Only			*B – 107 Keyboard Only		
* 5 – 105 Keyboard Only			*J – 109 Keyboard Only		

Key Number and Symbol		HID Page	HID Code
131 (*J)	Japanese J131	07	8B
132 (*J)	Japanese J132	07	8A
133 (*J)	Japanese J133	07	88
150	Korea KC-L, Key_Hangul	07	90
151	Korea KC-R, Key_Hanja	07	91
ACPI	Power	01	81
ACPI	Sleep	01	82
ACPI	Wake-up	01	83
Windows Key	L WIN	07	E3
Windows Key	R WIN	07	E7
Windows Key	APP	07	65

Multimedia Key Number and Symbol	HID Page	HID Code
E-Mail	0C	018A
WWW Home	0C	0223
WWW Favorites	0C	022A
WWW Search	0C	0221
WWW Refresh	0C	0227
WWW Stop	0C	0226
WWW Forward	0C	0225
WWW Back	0C	0224
Media	0C	0183
Play/Pause	0C	00CD
CD Stop	0C	00B7
Prev Track	0C	00B6
Next Track	0C	00B5
Volume+	0C	00E9
Volume-	0C	00EA
Mute	0C	00E2
My Computer	0C	0194
Calculator	0C	0192
The following keys need a driver		
Explorer (Internet Browser)	0C	0196
Screen Save	0C	019E
Record	0C	00B2
Rewind	0C	00B4
Minimize	0C	0206

**Function Key Usage**

Key Location	Status							
	Fn	Num Lock	Fn	Num Lock	Fn	Num Lock	Fn	Num Lock
	OFF	OFF	ON	OFF	OFF	ON	ON	ON
7	&7		Home		7		7	
8	*8		↑		8		8	
9	(9		PgUp		9		9	
0	)0		*		*		0	
U	U		←		4		U	
I	I				5		I	
O	O		→		6		O	
P	P		-		-		P	
J	J		End		1		J	
K	K		↓		2		K	
L	L		PgDn		3		L	
::	::		+		+		::	
M	M		Ins		0		M	
>.	>.		Del		.		>.	
?/	?/		/		/		?/	
Enter	Enter (L)		Enter(R)		Enter(R)		Enter(L)	
F1/F11	F1		F11		F1		F11	
F2/F12	F2		F12		F2		F12	
F10/ ScrLock	F10		ScrLock		F10		ScrLock	
↑/PgUp	↑		Page Up		↑		Page Up	
↓/PgDn	↓		Page Down		↓		Page Down	
←/Home	←		Home		←		Home	
→/End	→		End		→		End	

**Key Matrix**

	R0/PA0	R1/PA1	R2/PA2	R3/PA3	R4/PA4	R5/PA5	R6/PA6	R7/PA7
<b>C0/PB0</b>	PAUSE 126	Pre Track	Stop	Play/Pause	CTRL-R 64	Next Track	CTRL-L 58	F5 116
<b>C1/PB1</b>	Q 17	TAB 16	A 31	ESC 110	Z 46	N-CHG 131	'(~) 1	1(!) 2
<b>C2/PB2</b>	W 18	CAPS 30	S 32	(\) 45	X 47	CHG 132	F1 112	2(@) 3
<b>C3/PB3</b>	E 19	F3 114	D 33	F4 115	C 48	ROMA 133	F2 113	3(#) 4
<b>C4/PB4</b>	R 20	T 21	F 34	G 35	V 49	B 50	5(%) 6	4(\$) 5
<b>C5/PB5</b>	U 23	Y 22	J 37	H 36	M 52	N 51	6(^) 7	7(&) 8
<b>C6/PB6</b>	I 24	]}) 28	K 38	F6 117	,(<) 53	\(-) 56	=(+) 13	8(*) 9
<b>C7/PB7</b>	O 25	F7 118	L 39		.(>) 54	APP 119	F8 119	9('') 10
<b>C8/PD0</b>	7(Home) 91	4(←) 92	1(End) 93	SPACE 61	NUM LOCK 90	↓ 84	DEL 76	POWER
<b>C9/PD1</b>	(\) 14	BACK 15	\( ) 29	F11 122	ENTER-L 43	F12 123	F9 120	F10 121
<b>C10/PD2</b>	SCROLL 125		Vol- 60	ALT-L 60	Vol+ 62	ALT-R 62	Mute	PRINT SCREEN
<b>C11/PD3</b>	P 26	[{) 27	:(:) 40	'(") 41	(\) 42	/(?) 55	_(-) 12	0(') 11
<b>C12/PD4</b>	Screen Save	WIN-L		Rec	Rew	Min	Eject	F10/ Scroll
<b>C13/PD5</b>	KC-L 150		WIN-R	00	000		F2/F12	KC-R 151
<b>C14/PD6</b>	Media	E-mail	WWW Home	WWW Back	WWW Forward	WWW Stop	WWW Refresh	WWW Bkmk
<b>C15/PD7</b>	My Computer	Calculator	↑/ Page Up	↓/ Page Down	←/ Home	→/ END	Explorer	
<b>C16/PC4</b>	Wake-up	SHIFT-L 44	SHIFT-R 57	WWW Search			F1/F11	FN
<b>C17/PC5</b>	+ 106	. 107	ENTER-R 108	↑ 83		← 79	HOME 80	END 81
<b>C18/PC6</b>	9(PgUp) 101	6(→) 102	3(PgDn) 103	.(Del) 104	* 100	- 105	PgUp 85	PgDn 86
<b>C19/PC7</b>	8(↑) 96	5 97	2(↓) 98	0(Ins) 99	/ 95	→ 89	INS 75	SLEEP

The following table shows which key needs a driver in the different OS

<b>OS</b>	<b>Key Need Drive</b>
MS DOS, Win95	<ul style="list-style-type: none"><li>• Media, My computer, Calculator</li><li>• E-mail, WWW Home, WWW Back, WWW Forward, WWW Stop, WWW Refresh, WWW Favorite, WWW Search</li><li>• Vol-, Vol+, Mute, Pre Track, CD Stop, Play/Pause, Next Track</li><li>• Rec, Rew, Min, Eject, Screen Save, Explorer</li><li>• Power, Wake-up, Sleep</li></ul>
Win 98	<ul style="list-style-type: none"><li>• Media, My computer, Calculator</li><li>• E-mail, WWW Home, WWW Back, WWW Forward, WWW Stop, WWW Refresh, WWW Favorite, WWW Search</li><li>• Vol-, Vol+, Mute, Pre Track, CD Stop, Play/Pause, Next Track</li><li>• Rec, Rew, Min, Eject, Screen Save, Explorer</li></ul>
Win ME, Win 2K, Win XP	<ul style="list-style-type: none"><li>• Rec, Rew, Min, Eject, Screen Save, Explorer</li></ul>

Application Circuits

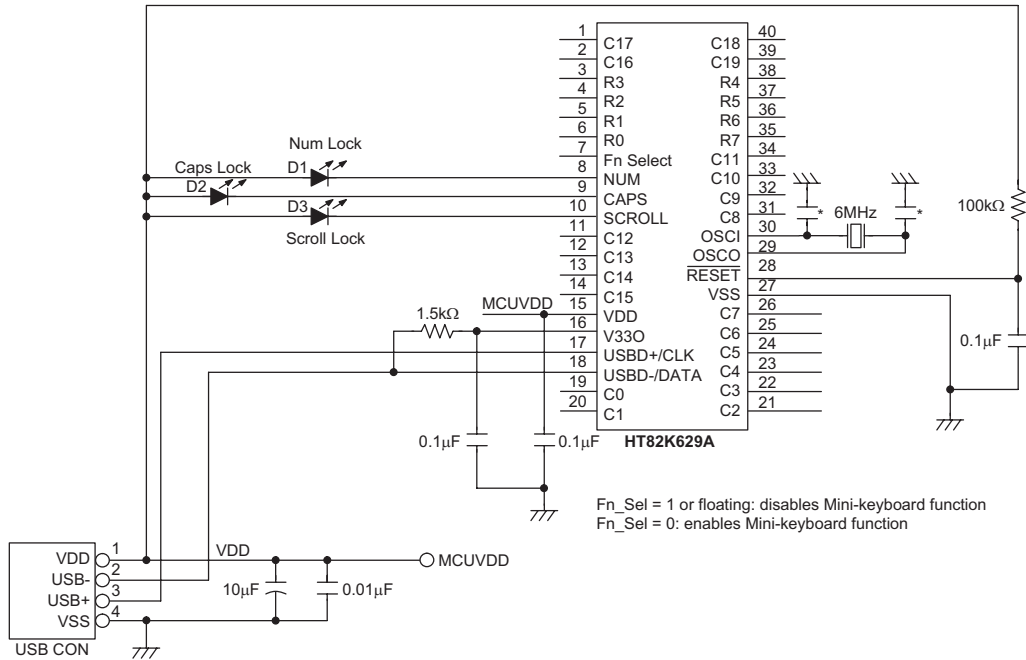

Note: For single side PCB, the GND should be routed first. Avoid routing the GND line and VDD line with jumping wires.

The GND and VDD lines should be as wide as possible, also it is recommended that the GND and VDD lines are placed in an empty area, in order to increase their area. Wherever possible the GND plane should surround pins such as OSC1, OSC0, VDD, V330, RESET etc and other related circuits to minimize the noise effects.

The GND/VDD loop area should be minimized. Try to keep GND and VDD lines parallel.

Allow room in the layout for the 0.1µF capacitor that is connected to the VDD pin. This capacitor should be connected as close as possible to the VDD pin. The function of this capacitor is to filter out high frequency noise.

The lines connecting the OSC1 and OSC0 pins to the crystal must be kept as short as possible to minimize any cross coupling of noise from these pins.

The 0.1µF capacitor connected to the RESET pin should be placed as close as possible to the RESET pin. The function of this capacitor is to filter out high frequency noise to minimize the possibility of a glitch on this line causing a false reset.

The 0.1µF capacitor connected to the V330 pin should be placed as close as possible to the V330 pin.

The USB+ and USB- lines to the USB connector should be kept as short as possible and should not be placed close to the other lines to reduce the possibility of noise coupling into other lines. The externally connected 1.5kΩ resistor connected to the USB- pin should be placed as close to as possible the USB- pin.

The USB cable should preferably have proper shielding.

Components with \* are used for resonator only if necessary.

**Package Information**

40-pin DIP (600mil) outline dimensions

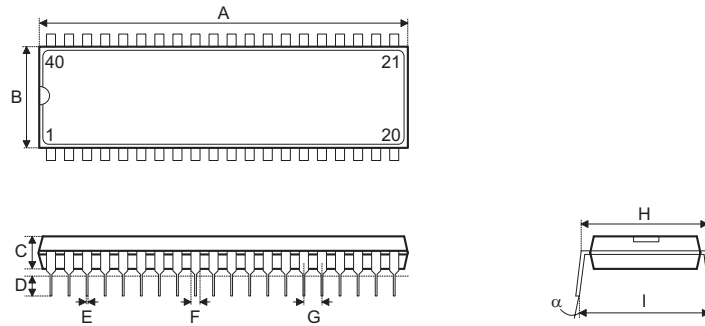

Symbol	Dimensions in mil		
	Min.	Nom.	Max.
A	2045	—	2065
B	535	—	555
C	145	—	155
D	125	—	145
E	16	—	20
F	50	—	70
G	—	100	—
H	595	—	615
I	635	—	670
$\alpha$	0°	—	15°

**Holtek Semiconductor Inc. (Headquarters)**

No.3, Creation Rd. II, Science Park, Hsinchu, Taiwan  
Tel: 886-3-563-1999  
Fax: 886-3-563-1189  
<http://www.holtek.com.tw>

**Holtek Semiconductor Inc. (Taipei Sales Office)**

4F-2, No. 3-2, YuanQu St., Nankang Software Park, Taipei 115, Taiwan  
Tel: 886-2-2655-7070  
Fax: 886-2-2655-7373  
Fax: 886-2-2655-7383 (International sales hotline)

**Holtek Semiconductor Inc. (Shanghai Sales Office)**

7th Floor, Building 2, No.889, Yi Shan Rd., Shanghai, China 200233  
Tel: 86-21-6485-5560  
Fax: 86-21-6485-0313  
<http://www.holtek.com.cn>

**Holtek Semiconductor Inc. (Shenzhen Sales Office)**

5/F, Unit A, Productivity Building, Cross of Science M 3rd Road and Gaoxin M 2nd Road, Science Park, Nanshan District, Shenzhen, China 518057  
Tel: 86-755-8616-9908, 86-755-8616-9308  
Fax: 86-755-8616-9722

**Holtek Semiconductor Inc. (Beijing Sales Office)**

Suite 1721, Jinyu Tower, A129 West Xuan Wu Men Street, Xicheng District, Beijing, China 100031  
Tel: 86-10-6641-0030, 86-10-6641-7751, 86-10-6641-7752  
Fax: 86-10-6641-0125

**Holtek Semiconductor Inc. (Chengdu Sales Office)**

709, Building 3, Champagne Plaza, No.97 Dongda Street, Chengdu, Sichuan, China 610016  
Tel: 86-28-6653-6590  
Fax: 86-28-6653-6591

**Holtek Semiconductor (USA), Inc. (North America Sales Office)**

46729 Fremont Blvd., Fremont, CA 94538  
Tel: 1-510-252-9880  
Fax: 1-510-252-9885  
<http://www.holtek.com>

Copyright © 2007 by HOLTEK SEMICONDUCTOR INC.

The information appearing in this Data Sheet is believed to be accurate at the time of publication. However, Holtek assumes no responsibility arising from the use of the specifications described. The applications mentioned herein are used solely for the purpose of illustration and Holtek makes no warranty or representation that such applications will be suitable without further modification, nor recommends the use of its products for application that may present a risk to human life due to malfunction or otherwise. Holtek's products are not authorized for use as critical components in life support devices or systems. Holtek reserves the right to alter its products without prior notification. For the most up-to-date information, please visit our web site at <http://www.holtek.com.tw>.