

**Product Specification**  
**R0605300L**

Si Reverse, low current, 5 – 65MHz, 30.2dB typ. Gain @ 65MHz, 140mA max. @ 24VDC



**FEATURES**

- Excellent linearity
- Superior return loss performance
- Extremely low distortion
- Optimal reliability
- Low noise
- Unconditionally stable under all terminations

**APPLICATION**

- 5 to 65 MHz CATV amplifier for reverse channel systems

**DESCRIPTION**

- Hybrid reverse amplifier employing silicon dies

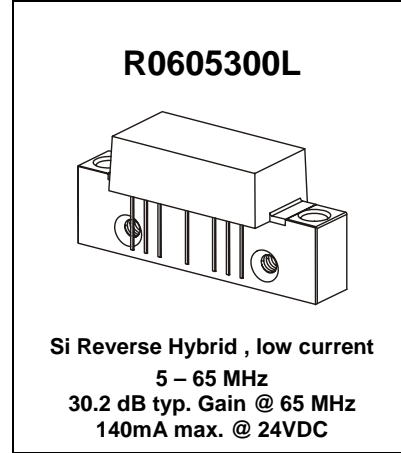

**LIMITING VALUES**

In accordance with the Absolute Maximum Rating System (IEC 60134)

SYMBOL	PARAMETER	MIN.	MAX.	UNIT
V <sub>i</sub>	RF input voltage (single tone)	-	65	dBmV
V <sub>ov</sub>	DC supply over-voltage (5 minutes)	-	30	V
T <sub>stg</sub>	storage temperature	- 40	+ 100	°C
T <sub>mb</sub>	operating mounting base temperature	- 30	+ 100	°C

**CHARACTERISTICS**

Table 1: S-Parameter, Noise Figure, DC Current; V<sub>B</sub> = 24V; T<sub>mb</sub> = 30°C; Z<sub>S</sub> = Z<sub>L</sub> = 75 Ω

SYMBOL	PARAMETER	CONDITIONS	MIN.	TYP.	MAX.	UNIT
G <sub>p</sub>	power gain	f = 5 MHz	29.5	30.0	30.5	dB
		f = 65 MHz	29.3	30.2	-	dB
SL	slope <sup>1)</sup>	f = 5 to 65 MHz	-0.2	0.1	0.4	dB
FL	flatness of frequency response	f = 5 to 65 MHz	-		± 0.3	dB
S <sub>11</sub>	input return loss	f = 5 to 65 MHz	20.0		-	dB
S <sub>22</sub>	output return loss	f = 5 to 65 MHz	20.0		-	dB
F	noise figure	f = 65 MHz	-	1.8	3.0	dB
I <sub>tot</sub>	total current consumption (DC)		125.0	130	140.0	mA

Notes:

1) The slope is defined as the difference between the gain at the start frequency and the gain at the stop frequency.

**Product Specification**  
**R0605300L**

SI Reverse, low current, 5 – 65MHz, 30.2dB typ. Gain @ 65MHz, 140mA max. @ 24VDC



**CHARACTERISTICS**

Table 2: Distortion data 5 – 65 MHz;  $V_B = 24V$ ;  $T_{mb} = 30^\circ C$ ;  $Z_S = Z_L = 75 \Omega$

SYMBOL	PARAMETER	CONDITION	MIN.	TYP.	MAX.	UNIT
CTB	composite triple beat	7 ch. flat; $V_o = 50 \text{ dBmV}^{1)}$	-		- 64	dBc
XMOD	cross modulation	7 ch. flat; $V_o = 50 \text{ dBmV}^{1)}$	-		- 55	dB
CSO	composite second order distortion	7 ch. flat; $V_o = 50 \text{ dBmV}^{1)}$	-		- 68	dBc
$d_2$	second order distortion				- 70	dBc
STB	third order distortion				- 66	dBc

Notes:

- 1) 7 channels, US frequency raster: T7 – T13 (7.0 to 43.0 MHz), +50 dBmV flat output level.
- 2)  $f_1 = 7 \text{ MHz}$ ;  $V_1 = 50 \text{ dBmV}$ ;  $f_2 = 25 \text{ MHz}$ ;  $V_2 = 50 \text{ dBmV}$ ;  $f_{TEST} = f_1 + f_2 = 32 \text{ MHz}$ .
- 3)  $f_1 = 13 \text{ MHz}$ ;  $V_1 = 50 \text{ dBmV}$ ;  $f_2 = 25 \text{ MHz}$ ;  $V_2 = V_1$ ;  $f_3 = 7 \text{ MHz}$ ;  $V_3 = V_1$ ;  
 $f_{TEST} = f_1 + f_2 - f_3 = 31 \text{ MHz}$ .

**Composite Second Order (CSO)**

The CSO parameter (both sum and difference products) is defined by the NCTA.

**Composite Triple Beat (CTB)**

The CTB parameter is defined by the NCTA.

**Cross Modulation (XMOD)**

Cross modulation (XMOD) is measured at baseband (selective voltmeter method), referenced to 100% modulation of the carrier being tested.

**Product Specification**  
**R0605300L**

Si Reverse, low current, 5 – 65MHz, 30.2dB typ. Gain @ 65MHz, 140mA max. @ 24VDC

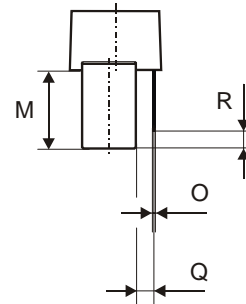
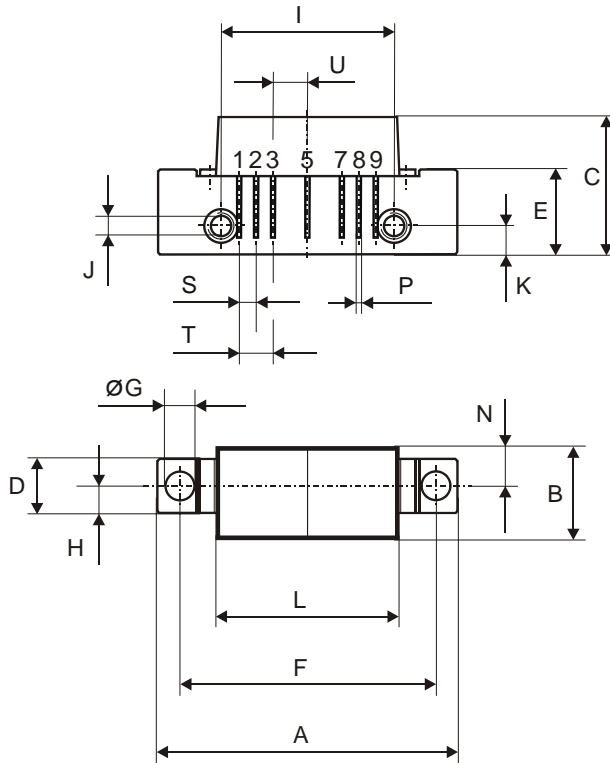

All Dimensions in mm:

	nominal	min	max
A	44,6 ± 0,2	44,4	44,8
B	13,6 ± 0,2	13,4	13,8
C	20,4 ± 0,5	19,9	20,9
D	8 ± 0,15	7,85	8,15
E	12,6 ± 0,15	12,45	12,75
F	38,1 ± 0,2	37,9	38,3
G	4 +0,2 / -0,05	3,95	4,2
H	4 ± 0,2	3,8	4,2
I	25,4 ± 0,2	25,2	25,6
J	UNC 6-32	-	-
K	4,2 ± 0,2	4,0	4,4
L	27,2 ± 0,2	27,0	27,4
M	11,6 ± 0,5	11,1	12,1
N	5,8 ± 0,4	5,4	6,2
O	0,25 ± 0,02	0,23	0,27
P	0,45 ± 0,03	0,42	0,48
Q	2,54 ± 0,3	2,24	2,84
R	2,54 ± 0,5	2,04	3,04
S	2,54 ± 0,25	2,29	2,79
T	5,08 ± 0,25	4,83	5,33
U	5,08 ± 0,25	4,83	5,33

**Pinning:**

	1	2	3	4	5	6	7	8	9
	INPUT	GND	GND	+VB	GND	GND	GND	OUTPUT	

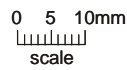

**Notes:**

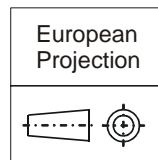

<b>Product Specification</b> <b>R0605300L</b>  <small>SI Reverse, low current, 5 – 65MHz, 30.2dB typ. Gain @ 65MHz, 140mA max. @ 24VDC</small>	
---	--

## DEFINITIONS

<b>Data Sheet Status</b>	
Objective Product Specification	This data sheet contains target or goal specifications for product development.
Preliminary Product Specification	This data sheet contains preliminary data; supplementary data may be published later.
Product Specification	This data sheet contains final product specifications.
<b>Limiting values</b>	
Limiting values given are in accordance with the Absolute Maximum Rating System (IEC 60134). Stress above one or more of the limiting values may cause permanent damage to the device. These are stress ratings only and operation of the device at these or at any other conditions above those given in the Characteristics sections of the specification is not implied. Exposure to limiting values for extended periods may affect device reliability.	
<b>Application information</b>	
Where application information is given, it is advisory and does not form part of the specification.	

RFMD Germany GmbH reserves the right to make changes without further notice to any products herein. RFMD Germany GmbH makes no warranty representation or guarantee regarding the suitability of its products for any particular purpose, nor does RFMD Germany GmbH assume any liability arising out of the application or use of any product or circuit, and specifically disclaims any and all liability, including without limitation consequential or incidental damages. "Typical" parameters which may be provided in RFMD Germany GmbH datasheets and/or specifications can and do vary in different applications and actual performance may vary over time. All operating parameters, including "Typicals" must be validated for each customer application by customer's technical experts. RFMD Germany GmbH does not convey any license under its patent rights nor the rights of others. RFMD Germany GmbH products are not designed, intended, or authorized for use as components in systems intended for surgical implant into the body, or other applications intended to support or sustain life, or for any other application in which the failure of the RFMD Germany GmbH product could create a situation where personal injury or death may occur. Should Buyer purchase or use Premier Devices products for any such unintended or unauthorized application, Buyer shall indemnify and hold RFMD Germany GmbH and its officers, employees, subsidiaries, affiliates, and distributors harmless against all claims, costs, damages, and expenses, and reasonable attorney fees arising out of, directly or indirectly, and claim of personal injury or death associated with such unintended or unauthorized use, even if such claim alleges that RFMD Germany GmbH was negligent regarding the design or manufacture of the part.

© RFMD Germany GmbH 2008

### How to contact us:

RFMD Germany GmbH

Loeffelholzstrasse 20, D-90441 Nuernberg, Germany  
 Phone: +49 (0) 911 9411 233, FAX: +49 (0) 911 9411 198,  
 Email: [sales.germany@rfmd.com](mailto:sales.germany@rfmd.com), Internet: <http://www.rfmd.com/>

Page 4 of 4	2008 Mar 20	Document Revision Level F
-------------	-------------	---------------------------