

Single-chip 8-bit microcontroller

8031AH/8051AH

DESCRIPTION

The Philips 8031AH/8051AH is a high-performance microcontroller fabricated with Philips high-density highly reliable +5V, depletion-load, N-channel, silicon-gate, N500 MOS process technology. It provides the hardware features, architectural enhancements and instructions that are necessary to make it a powerful and cost-effective controller for applications requiring up to 64k bytes of program memory and/or up to 64k bytes of data storage.

The 8051AH contains a 4k x 8 read-only program memory, a 128 x 8 read-only data memory, 32 I/O lines, two 16-bit counter/timers, a five-source, two-priority level nested interrupt structure, a serial I/O port for either multi-processor communications, I/O expansion or full duplex UART, and on-chip oscillator and clock circuits. The 8031AH is identical, except that it lacks the program memory. For systems that require extra capability, the 8051AH can be expanded using standard TTL compatible memories and byte oriented peripheral controllers.

The 8051AH microcontroller, like its 8048 predecessor, is efficient both as a controller and as an arithmetic processor. It has extensive facilities for binary and BCD arithmetic and excels in bit-handling capabilities. Efficient use of program memory results from an instruction set consisting of 44% one-byte, 41% two-byte, and 15% three-byte instructions. With a 12MHz crystal, 58% of the instructions execute in 1µs, 40% in 2µs and multiply and divide require only 4µs.

FEATURES

- Reduced supply current
- 4k x 8 ROM (8051AH)
- 128 x 8 RAM
- Four 8-bit ports, 32 I/O lines
- Two 16-bit timer/event counters
- High-performance full-duplex serial channel
- External memory expandable to 128k
- Boolean processor
- Industry standard 8051 architecture:
 - Non-paged jumps
 - Direct addressing
 - Four 8-register banks
 - Stack depth up to 128-bytes
 - Multiply, divide, subtract, compare
- Most instructions execute in 1µs
- 4µs multiply and divide

PIN CONFIGURATIONS

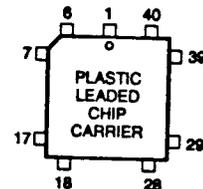
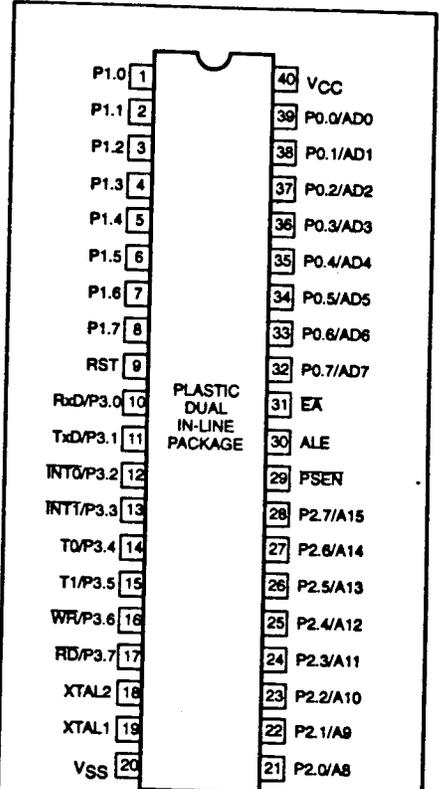

Pin	Function	Pin	Function	Pin	Function
1	NC	15	INT1/P3.3	30	P2.6/A14
2	P1.0	16	T0/P3.4	31	P2.7/A15
3	P1.1	17	T1/P3.5	32	PSEN
4	P1.2	18	WR/P3.6	33	ALE
5	P1.3	19	RD/P3.7	34	NC
6	P1.4	20	XTAL2	35	EA
7	P1.5	21	XTAL1	36	P0.7/AD7
8	P1.6	22	VSS	37	P0.6/AD6
9	P1.7	23	NC	38	P0.5/AD5
10	RST	24	P2.0/A8	39	P0.4/AD4
11	RxD/P3.0	25	P2.1/A9	40	P0.3/AD3
12	NC	26	P2.2/A10	41	P0.2/AD2
13	TxD/P3.1	27	P2.3/A11	42	P0.1/AD1
14	INT0/P3.2	28	P2.4/A12	43	P0.0/AD0
		29	P2.5/A13	44	VCC

LOGIC SYMBOL

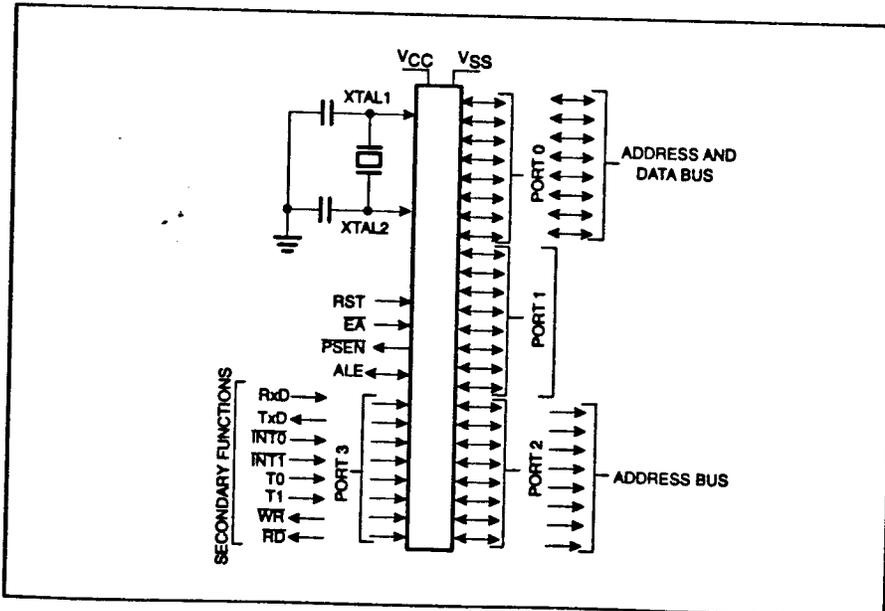

Single-chip 8-bit microcontroller

8031AH/8051AH

PART NUMBER SELECTION

PHILIPS			PHILIPS NORTH AMERICA		TEMPERATURE °C AND PACKAGE	FREQ. MHz	DRAWING NUMBER
ROMless (MARKING NUMBER)	ROMless (ORDER NUMBER)	ROM	ROMless	ROM			
MAF8031AH-2-12P	MAF8031A-2 N	MAF8051AH-2P	SCN8031HACN40	SCN8051HACN40	-40 to +85, Plastic Dual In-Line Package	12	0415C
MAB8031AH-2-12P	MAB8031A-2 N	MAB8051AH-2P	SCN8031HCCN40	SCN8051HCCN40	0 to +70, Plastic Dual In-Line Package	12	0415C
			SCN8031HCFN40	SCN8051HCFN40	0 to +70, Plastic Dual In-Line Package	15	0415C
			SCN8031HAFN40	SCN8051HAFN40	-40 to +85, Plastic Dual In-Line Package	15	0415C
MAB8031AH-2-12WP	MAB8031A-2 A	MAB8051AH-2WP	SCN8031HCCA44	SCN8051HCCA44	0 to +70, Plastic Leaded Chip Carrier	12	0403G
MAF8031AH-2-12WP	MAF8031A-2 A	MAF8051AH-2WP	SCN8031HACA44	SCN8051HACA44	-40 to +85, Plastic Leaded Chip Carrier	12	0403G
			SCN8031HCFA44	SCN8051HCFA44	0 to +70, Plastic Leaded Chip Carrier	15	0403G
			SCN8031HAFA44	SCN8051HAFA44	-40 to +85, Plastic Leaded Chip Carrier	15	0403G

Single-chip 8-bit microcontroller

8031AH/8051AH

BLOCK DIAGRAM

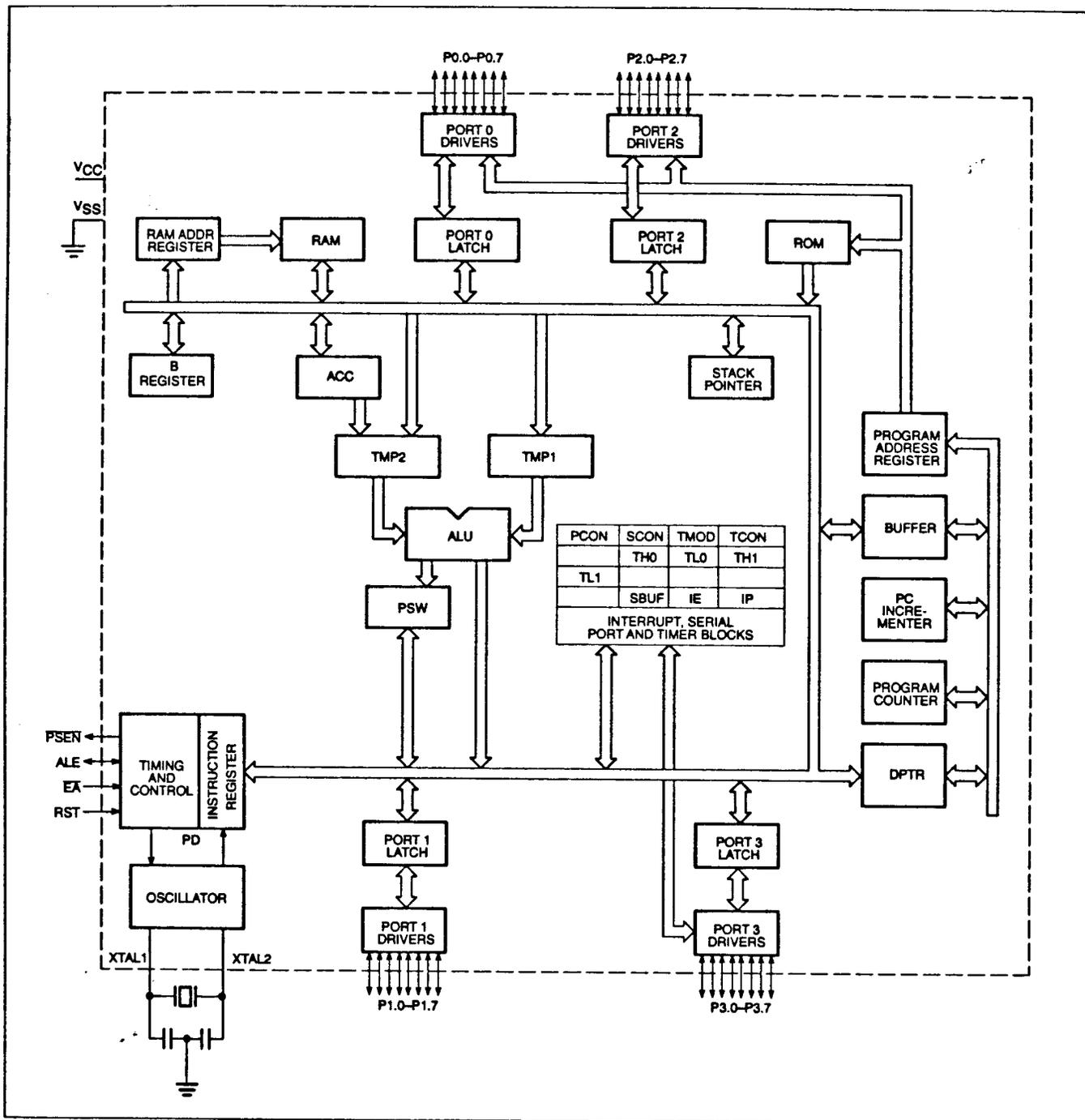

Single-chip 8-bit microcontroller

8031AH/8051AH

PIN DESCRIPTIONS

MNEMONIC	PIN NO.		TYPE	NAME AND FUNCTION
	DIP	LCC		
V _{SS}	20	22	I	Ground: 0V reference.
V _{CC}	40	44	I	Power Supply: This is the power supply voltage for normal, idle, and power-down operation.
P0.0–P0.7	39–32	43–36	I/O	Port 0: Port 0 is an open-drain, bidirectional I/O port. Port 0 pins that have 1s written to them float and can be used as high-impedance inputs. Port 0 is also the multiplexed low-order address and data bus during accesses to external program and data memory. In this application, it uses strong internal pull-ups when emitting 1s.
P1.0–P1.7	1–8	2–9	I/O	Port 1: Port 1 is an 8-bit bidirectional I/O port with internal pull-ups. Port 1 pins that have 1s written to them are pulled high by the internal pull-ups and can be used as inputs. As inputs, port 1 pins that are externally pulled low will source current because of the internal pull-ups. (See DC Electrical Characteristics: I _{IL}).
P2.0–P2.7	21–28	24–31	I/O	Port 2: Port 2 is an 8-bit bidirectional I/O port with internal pull-ups. Port 2 pins that have 1s written to them are pulled high by the internal pull-ups and can be used as inputs. As inputs, port 2 pins that are externally being pulled low will source current because of the internal pull-ups. (See DC Electrical Characteristics: I _{IL}). Port 2 emits the high-order address byte during fetches from external program memory and during accesses to external data memory that use 16-bit addresses (MOVX @DPTR). In this application, it uses strong internal pull-ups when emitting 1s. During accesses to external data memory that use 8-bit addresses (MOV @Ri), port 2 emits the contents of the P2 special function register.
P3.0–P3.7	10–17	11, 13–19	I/O	Port 3: Port 3 is an 8-bit bidirectional I/O port with internal pull-ups. Port 3 pins that have 1s written to them are pulled high by the internal pull-ups and can be used as inputs. As inputs, port 3 pins that are externally being pulled low will source current because of the pull-ups. (See DC Electrical Characteristics: I _{IL}). Port 3 also serves the special features of the 80C51 family, as listed below:
			I	RxD (P3.0): Serial input port
			O	TxD (P3.1): Serial output port
			I	INT0 (P3.2): External interrupt
			I	INT1 (P3.3): External interrupt
			I	T0 (P3.4): Timer 0 external input
			I	T1 (P3.5): Timer 1 external input
			O	WR (P3.6): External data memory write strobe
			O	RD (P3.7): External data memory read strobe
RST	9	10	I	Reset: A high on this pin for two machine cycles while the oscillator is running, resets the device. An internal diffused resistor to V _{SS} permits a power-on reset using only an external capacitor to V _{CC} .
ALE	30	33	I/O	Address Latch Enable: Output pulse for latching the low byte of the address during an access to external memory. In normal operation, ALE is emitted at a constant rate of 1/6 the oscillator frequency, and can be used for external timing or clocking. Note that one ALE pulse is skipped during each access to external data memory.
PSEN	29	32	O	Program Store Enable: The read strobe to external program memory. When the device is executing code from the external program memory, PSEN is activated twice each machine cycle, except that two PSEN activations are skipped during each access to external data memory. PSEN is not activated during fetches from internal program memory.
EA	31	35	I	External Access Enable: EA must be externally held low to enable the device to fetch code from external program memory locations 0000H to 0FFFH. If EA is held high, the device executes from internal program memory unless the program counter contains an address greater than 0FFFH.
XTAL1	19	21	I	Crystal 1: Input to the inverting oscillator amplifier.
XTAL2	18	20	O	Crystal 2: Output from the inverting oscillator amplifier and input to the internal clock generator circuits.

OSCILLATOR CHARACTERISTICS

XTAL1 and XTAL2 are the input and output, respectively, of an inverting amplifier. The pins can be configured for use as an on-chip oscillator, as shown in the logic symbol.

To drive the device from an external clock source, XTAL2 should be driven while XTAL1 is connected to ground. There are no requirements on the duty cycle of the external clock signal, because the input to the internal clock circuitry is through a divide-by-two flip-flop. However, minimum and maximum

high and low times specified in the data sheet must be observed.

DESIGN CONSIDERATIONS

At power-on, the voltage on V_{CC} and RST should come up at the same time for a proper start-up.

Single-chip 8-bit microcontroller

8031AH/8051AH

ABSOLUTE MAXIMUM RATINGS^{1, 2, 3}

PARAMETER	RATING	UNIT
Storage temperature range	-65 to +150	°C
Voltage on any other pin to V _{SS}	-0.5 to +7.0	V
Input, output current on any single pin	10	mA
Power dissipation	1.0	W

DC ELECTRICAL CHARACTERISTICS

T_{amb} = 0°C to +70°C, V_{CC} = 5V ±10%, V_{SS} = 0V^{4, 5}

SYMBOL	PARAMETER	TEST CONDITIONS	LIMITS		UNIT
			MIN	MAX	
V _{IL}	Input low voltage		-0.5	0.8	V
V _{IH}	Input high voltage; except XTAL2, RST		2.0	V _{CC} +0.5	V
V _{IH1}	Input high voltage to RST for reset, XTAL2	XTAL1 to V _{SS}	2.5	V _{CC} +0.5	V
V _{OL}	Output low voltage; ports 1, 2, 3 ⁶	I _{OL} = 1.6mA		0.45	V
V _{OL1}	Output low voltage; port 0, ALE, PSEN ⁶	I _{OL} = 3.2mA		0.45	V
V _{OH}	Output high voltage; ports 1, 2, 3	I _{OH} = -80µA	2.4		V
V _{OH1}	Output high voltage; port 0, ALE, PSEN ³	I _{OH} = -400µA	2.4		V
I _{IL}	Logical 0 input current; ports 1, 2, 3	V _{IN} = 0.45V		-500	µA
I _{IH1}	Input high current to RST for reset	V _{IN} < V _{CC} - 1.5V		500	µA
I _I	Input leakage current; port 0, EA	0.45 < V _{IN} < V _{CC}		±10	µA
I _{IL2}	Logical 0 input current for XTAL2	XTAL1 = V _{SS} , V _{IN} = 0.45V		-3.2	mA
I _{CC}	Power supply current	All outputs disconnected and EA = V _{CC}		125	mA
C _{IO}	Pin capacitance			10	pF

T_{amb} = -40°C to +85°C, V_{CC} = 5V ±10%, V_{SS} = 0V

SYMBOL	PARAMETER	TEST CONDITIONS	LIMITS		UNIT
			MIN	MAX	
V _{IH}	Input high voltage; except XTAL2, RST		2.1	V _{CC} +0.5	V
V _{IH1}	Input high voltage to RST and XTAL2	XTAL1 = V _{SS}	2.6	V _{CC} +0.5	V
I _{IL2}	Logical 0 input current for XTAL2	XTAL1 = V _{SS} , V _{IN} = 0.45V		-4.0	mA
I _{CC}	Power supply current	All outputs disconnected and EA = V _{CC}		135	mA

NOTES:

- Stresses above those listed under Absolute Maximum Ratings may cause permanent damage to the device. This is a stress rating only and functional operation of the device at these or any conditions other than those described in the AC and DC Electrical Characteristics section of this specification is not implied.
- For operating at elevated temperatures, the device must be derated based on +150°C maximum junction temperature.
- This product includes circuitry specifically designed for the protection of its internal devices from the damaging effects of excessive static charge. Nonetheless, it is suggested that conventional precautions be taken to avoid applying greater than the rated maxima.
- Parameters are valid over operating temperature range unless otherwise specified. All voltages are with respect to V_{SS} unless otherwise noted.
- All voltage measurements are referenced to ground. For testing, all input signals swing between 0.45V and 2.4V with a transition time of 20ns maximum. All time measurements are referenced at input voltages of 0.8V and 2.0V and at output voltages of 0.8V and 2.0V as appropriate.
- V_{OL} is derated when the device rapidly discharges external capacitance. This AC noise is most pronounced during emission of address data. When using external memory, locate the latch or buffer as close as possible to the device.

Datum	Emitting Ports	Degraded I/O Lines	V _{OL} (Peak Max)
Address	P2, P0	P1, P3	0.8V
Write Data	P0	P1, p3, ALE	0.8V

- C_L = 100pF for port 0, ALE and PSEN outputs; C_L = 80pF for all other ports.

Single-chip 8-bit microcontroller

8031AH/8051AH

AC ELECTRICAL CHARACTERISTICS

 $T_{amb} = 0^{\circ}\text{C to } +70^{\circ}\text{C or } -40^{\circ}\text{C to } +85^{\circ}\text{C}$, $V_{CC} = 5\text{V } \pm 20\%$, $V_{SS} = 0\text{V}^{1,2}$

SYMBOL	FIGURE	PARAMETER	12MHz CLOCK		VARIABLE CLOCK		UNIT
			MIN	MAX	MIN	MAX	
$1/t_{CLCL}$		Oscillator frequency: Speed Versions SCN8051/31 C MAB8051/31 -2 MAF8051/31 -2 SCN8051/31 F			3.5 3.5 3.5 3.5	12 12 12 15	MHz MHz MHz MHz
t_{HLL}	1	ALE pulse width	127		$2t_{CLCL}-40$		ns
t_{AVLL}	1	Address valid to ALE low	43		$t_{CLCL}-40$		ns
t_{LLAX}	1	Address hold after ALE low	48		$t_{CLCL}-35$		ns
t_{LLIV}	1	ALE low to valid instruction in		233		$4t_{CLCL}-100$	ns
t_{LLPL}	1	ALE low to PSEN low	58		$t_{CLCL}-25$		ns
t_{PLPH}	1	PSEN pulse width	215		$3t_{CLCL}-35$		ns
t_{PLIV}	1	PSEN low to valid instruction in		125		$3t_{CLCL}-125$	ns
t_{PXIX}	1	Input instruction hold after PSEN	0		0		ns
t_{PXIZ}	1	Input instruction float after PSEN		63		$t_{CLCL}-20$	ns
t_{AVIV}	1	Address to valid instruction in		302		$5t_{CLCL}-115$	ns
t_{PLAZ}	1	PSEN low to address float		20		20	ns
t_{PXAV}	1	PSEN to address valid	75		$t_{CLCL}-8$		ns
Data Memory							
t_{RLRH}	2, 3	RD pulse width	400		$6t_{CLCL}-100$		ns
t_{WLWH}	2, 3	WR pulse width	400		$6t_{CLCL}-100$		ns
t_{RLDV}	2, 3	RD low to valid data in		252		$5t_{CLCL}-165$	ns
t_{RHDX}	2, 3	Data hold after RD	0		0		ns
t_{RHDZ}	2, 3	Data float after RD		97		$2t_{CLCL}-70$	ns
t_{LLDV}	2, 3	ALE low to valid data in		517		$8t_{CLCL}-150$	ns
t_{AVDV}	2, 3	Address to valid data in		585		$9t_{CLCL}-165$	ns
t_{LLWL}	2, 3	ALE low to RD or WR low	200	300	$3t_{CLCL}-50$	$3t_{CLCL}+50$	ns
t_{AVWL}	2, 3	Address valid to WR low or RD low	203		$4t_{CLCL}-130$		ns
t_{QVWX}	2, 3	Data valid to WR transition	23		$t_{CLCL}-60$		ns
t_{QVWH}	2, 3	Data valid to WR high	433		$7t_{CLCL}-150$		ns
t_{WHQX}	2, 3	Data hold after WR	33		$t_{CLCL}-50$		ns
t_{RLAZ}	2, 3	RD low to address float		20		20	ns
t_{WHLH}	2, 3	RD or WR high to ALE high	43	123	$t_{CLCL}-40$	$t_{CLCL}+40$	ns
External Clock							
t_{CHCX}	5	High time	20		20		ns
t_{CLCX}	5	Low time	20		20		ns
t_{CLCH}	5	Rise time		20		20	ns
t_{CHCL}	5	Fall time		20		20	ns

NOTES:

- Parameters are valid over operating temperature range unless otherwise specified.
- Load capacitance for port 0, ALE, and PSEN = 100pF, load capacitance for all other outputs = 80pF.

Single-chip 8-bit microcontroller

8031AH/8051AH

EXPLANATION OF THE AC SYMBOLS

Each timing symbol has five characters. The first character is always 't' (= time). The other characters, depending on their positions, indicate the name of a signal or the logical status of that signal. The designations are:

- A - Address
- C - Clock
- D - Input data
- H - Logic level high
- I - Instruction (program memory contents)
- L - Logic level low, or ALE
- P - PSEN

- Q - Output data
- R - RD signal
- t - Time
- V - Valid
- W - WR signal
- X - No longer a valid logic level
- Z - Float

Examples: t_{AVLL} = Time for address valid to ALE low.
 t_{LLPL} = Time for ALE low to PSEN low.

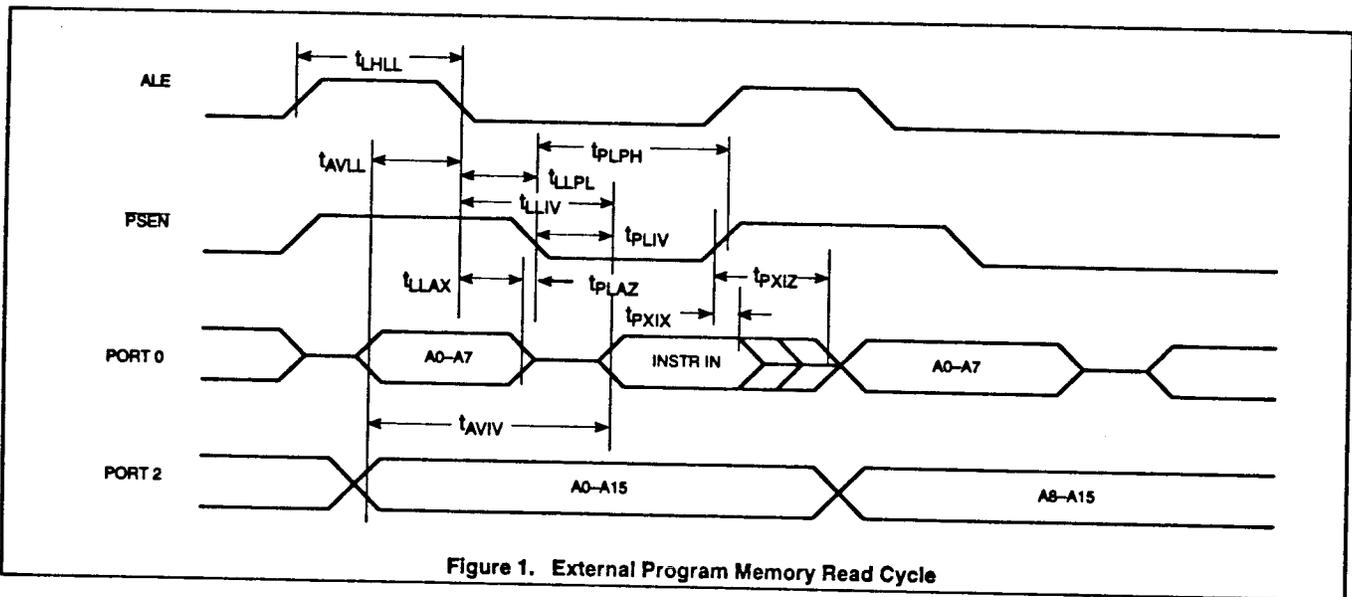

Figure 1. External Program Memory Read Cycle

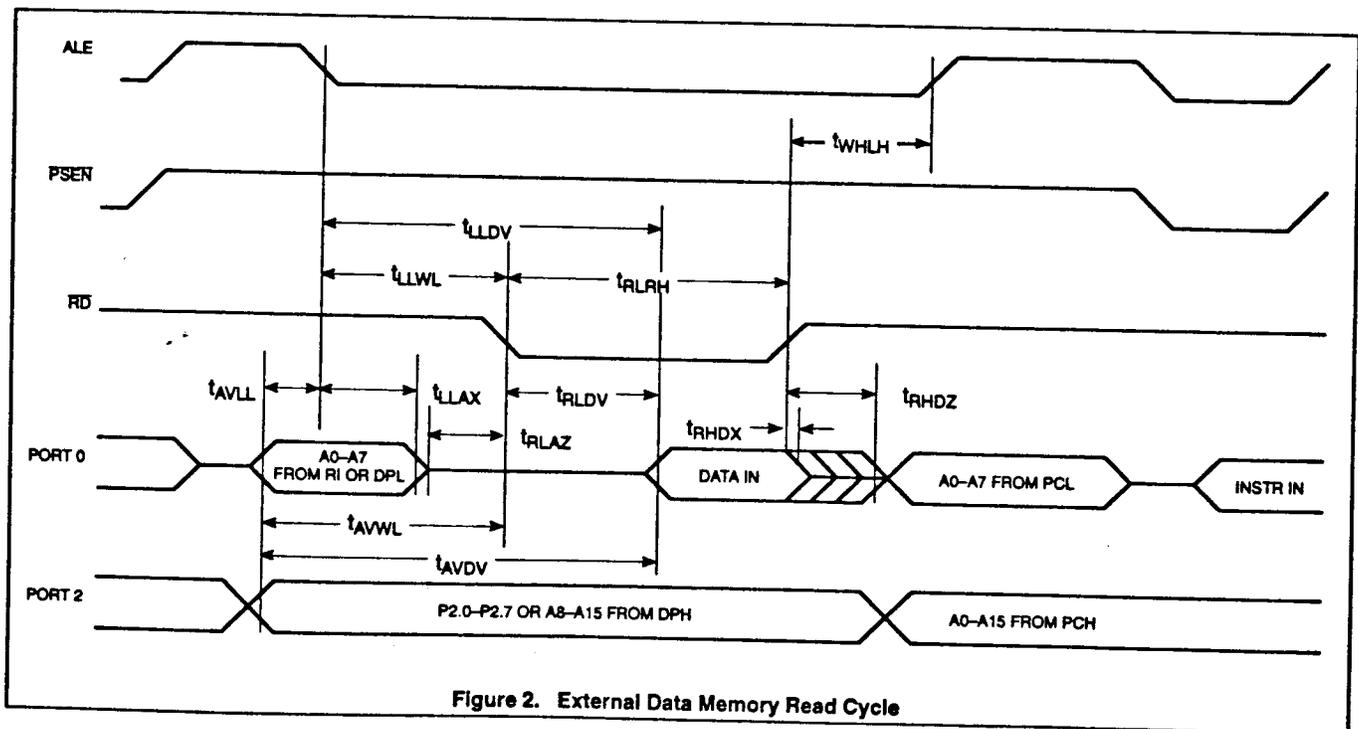

Figure 2. External Data Memory Read Cycle

Single-chip 8-bit microcontroller

8031AH/8051AH

