

2M x 32 SDRAM

*512K x 32bit x 4 Banks
Synchronous DRAM
LVTTL*

Revision 1.3

October 2001

Samsung Electronics reserves the right to change products or specification without notice.

Revision History**Revision 1.3 (October 24, 2000)**

- Removed CAS Latency 1 from the spec.

Revision 1.2 (August 7, 2000) - Target

- Added CAS Latency 1

Revision 1.1 (March 14, 2001)

- Added K4S643232E-55

Revision 1.0 (October 20, 2000)

- Removed Note 5 in page 9. tRDL is set to 2CLK in any case regardless of using AP or frequency

Revision 0.4 (August 24, 2000)

- Updated DC spec

Revision 0.3 (August 1, 2000)

- Changed the wording of tRDL related note for User's clear understanding

Revision 0.2 (July 18, 2000) - Preliminary

- Removed K4S643232E-40/55/7C
- Changed tSH of K4S643232E-45 from 0.7ns to 1.0ns

Revision 0.0 (March 14, 2000) - Target Spec.

- Initial draft

512K x 32Bit x 4 Banks Synchronous DRAM

FEATURES

- 3.3V power supply
- LVTTTL compatible with multiplexed address
- Four banks operation
- MRS cycle with address key programs
 - CAS latency (2 & 3)
 - Burst length (1, 2, 4, 8 & Full page)
 - Burst type (Sequential & Interleave)
- All inputs are sampled at the positive going edge of the system clock
- Burst read single-bit write operation
- DQM for masking
- Auto & self refresh
- 15.6us refresh duty cycle

GENERAL DESCRIPTION

The K4S643232E is 67,108,864 bits synchronous high data rate Dynamic RAM organized as 4 x 524,288 words by 32 bits, fabricated with SAMSUNG's high performance CMOS technology. Synchronous design allows precise cycle control with the use of system clock. I/O transactions are possible on every clock cycle. Range of operating frequencies, programmable burst length and programmable latencies allow the same device to be useful for a variety of high bandwidth, high performance memory system applications.

ORDERING INFORMATION

Part NO.	Max Freq.	Interface	Package
K4S643232E-TC/L45	222MHz	LVTTTL	86 TSOP(II)
K4S643232E-TC/L50	200MHz		
K4S643232E-TC/L55	183MHz		
K4S643232E-TC/L60	166MHz		
K4S643232E-TC/L70	143MHz		

FUNCTIONAL BLOCK DIAGRAM

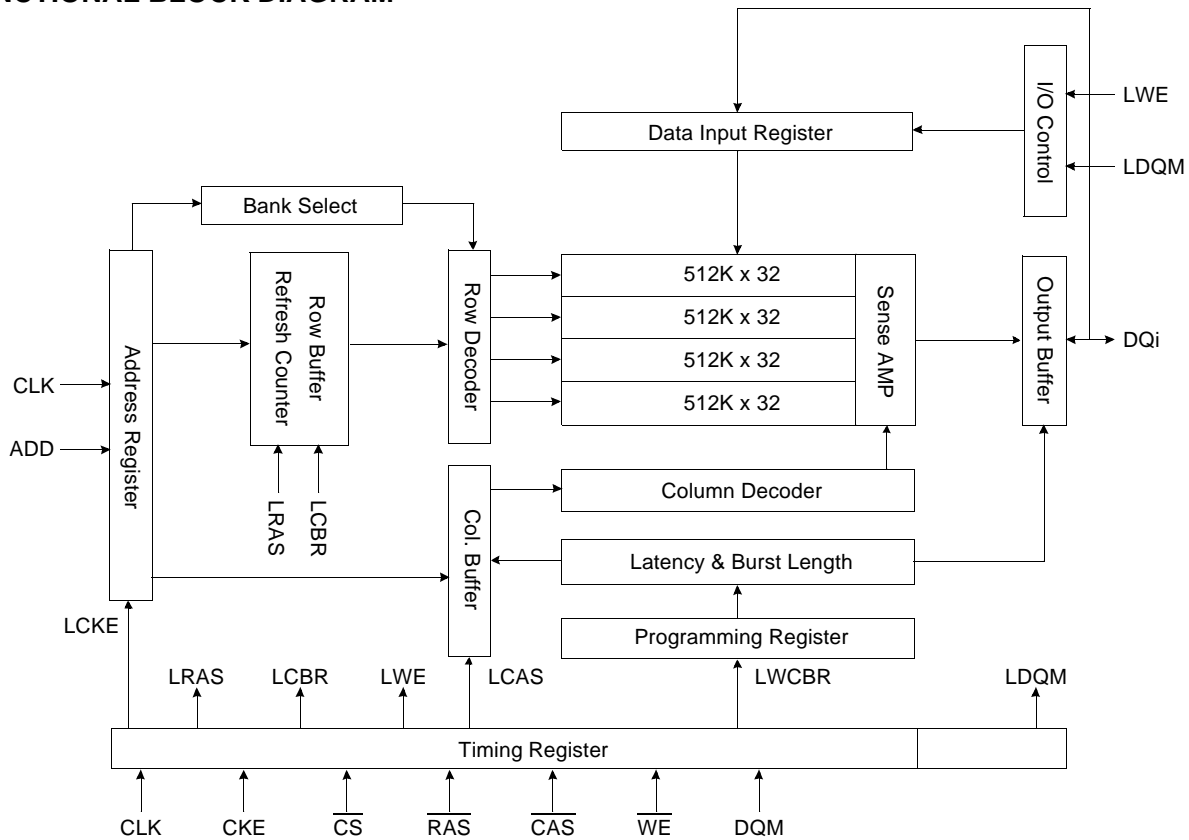

* Samsung Electronics reserves the right to change products or specification without notice.

PIN CONFIGURATION (Top view)

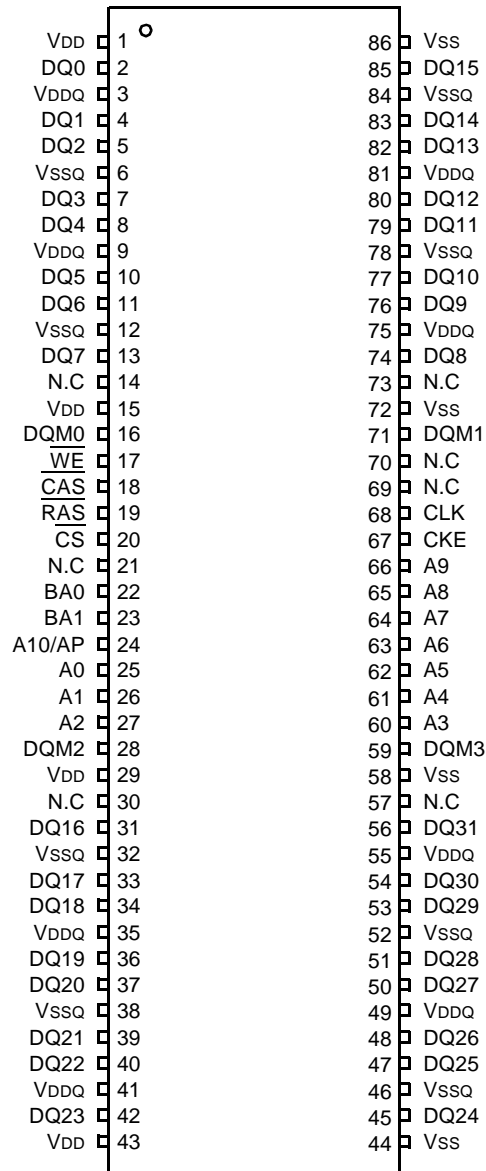

86Pin TSOP (II)
 (400mil x 875mil)
 (0.5 mm Pin pitch)

PIN FUNCTION DESCRIPTION

Pin	Name	Input Function
CLK	<i>System clock</i>	Active on the positive going edge to sample all inputs.
$\overline{\text{CS}}$	<i>Chip select</i>	Disables or enables device operation by masking or enabling all inputs except CLK, CKE and DQM.
CKE	<i>Clock enable</i>	Masks system clock to freeze operation from the next clock cycle. CKE should be enabled at least one cycle prior to new command. Disables input buffers for power down mode.
A ₀ ~ A ₁₀	<i>Address</i>	Row/column addresses are multiplexed on the same pins. Row address : RA ₀ ~ RA ₁₀ , Column address : CA ₀ ~ CA ₇
BA _{0,1}	<i>Bank select address</i>	Selects bank to be activated during row address latch time. Selects bank for read/write during column address latch time.
$\overline{\text{RAS}}$	<i>Row address strobe</i>	Latches row addresses on the positive going edge of the CLK with $\overline{\text{RAS}}$ low. Enables row access & precharge.
$\overline{\text{CAS}}$	<i>Column address strobe</i>	Latches column addresses on the positive going edge of the CLK with $\overline{\text{CAS}}$ low. Enables column access.
$\overline{\text{WE}}$	<i>Write enable</i>	Enables write operation and row precharge. Latches data in starting from $\overline{\text{CAS}}$, $\overline{\text{WE}}$ active.
DQM ₀ ~ 3	<i>Data input/output mask</i>	Makes data output Hi-Z, t _{SHZ} after the clock and masks the output. Blocks data input when DQM active.
DQ ₀ ~ 31	<i>Data input/output</i>	Data inputs/outputs are multiplexed on the same pins.
V _{DD} /V _{SS}	<i>Power supply/ground</i>	Power and ground for the input buffers and the core logic.
V _{DDQ} /V _{SSQ}	<i>Data output power/ground</i>	Isolated power supply and ground for the output buffers to provide improved noise immunity.
NC	<i>No Connection</i>	This pin is recommended to be left No connection on the device.

ABSOLUTE MAXIMUM RATINGS

Parameter	Symbol	Value	Unit
Voltage on any pin relative to Vss	V _{IN} , V _{OUT}	-1.0 ~ 4.6	V
Voltage on VDD supply relative to Vss	V _{DD} , V _{DDQ}	-1.0 ~ 4.6	V
Storage temperature	T _{STG}	-55 ~ +150	°C
Power dissipation	P _D	1	W
Short circuit current	I _{OS}	50	mA

Note : Permanent device damage may occur if "ABSOLUTE MAXIMUM RATINGS" are exceeded.
Functional operation should be restricted to recommended operating condition.
Exposure to higher than recommended voltage for extended periods of time could affect device reliability.

DC OPERATING CONDITIONS

Recommended operating conditions (Voltage referenced to Vss = 0V, T_A = 0 to 70°C)

Parameter	Symbol	Min	Typ	Max	Unit	Note
Supply voltage	V _{DD} , V _{DDQ}	3.0	3.3	3.6	V	
Input logic high voltage	V _{IH}	2.0	3.0	V _{DDQ} +0.3	V	1
Input logic low voltage	V _{IL}	-0.3	0	0.8	V	2
Output logic high voltage	V _{OH}	2.4	-	-	V	I _{OH} = -2mA
Output logic low voltage	V _{OL}	-	-	0.4	V	I _{OL} = 2mA
Input leakage current	I _{LI}	-10	-	10	µA	3

Notes : 1. V_{IH} (max) = 5.6V AC. The overshoot voltage duration is ≤ 3ns.
2. V_{IL} (min) = -2.0V AC. The undershoot voltage duration is ≤ 3ns.
3. Any input 0V ≤ V_{IN} ≤ V_{DDQ},
Input leakage currents include Hi-Z output leakage for all bi-directional buffers with Tri-State outputs.
4. The V_{DD} condition of K4S643232E-45/50/55/60 is 3.135V ~ 3.6V

CAPACITANCE (V_{DD} = 3.3V, T_A = 23°C, f = 1MHz, V_{REF} = 1.4V ± 200 mV)

Pin	Symbol	Min	Max	Unit
Clock	C _{CLK}	-	4	pF
RAS, CAS, WE, CS, CKE, DQM	C _{IN}	-	4.5	pF
Address	C _{ADD}	-	4.5	pF
DQ ₀ ~ DQ ₃₁	C _{OUT}	-	6.5	pF

DC CHARACTERISTICS

(Recommended operating condition unless otherwise noted, $T_A = 0$ to 70°C , $V_{IH(\min)}/V_{IL(\max)}=2.0\text{V}/0.8\text{V}$)

Parameter	Symbol	Test Condition	CAS Latency	Speed					Unit	Note
				-45	-50	-55	-60	-70		
Operating Current (One Bank Active)	Icc1	Burst Length =1 $t_{RC} \geq t_{RC(\min)}$, $t_{CC} \geq t_{CC(\min)}$, $I_o = 0\text{mA}$	3	180	175	175	170	155	mA	2
			2	150	150	150	150	150		
Precharge Standby Current in power-down mode	Icc2P	$\text{CKE} \leq V_{IL(\max)}$, $t_{CC} = 15\text{ns}$	3					mA		
	Icc2PS	$\text{CKE} \& \text{CLK} \leq V_{IL(\max)}$, $t_{CC} = \infty$	2							
Precharge Standby Current in non power-down mode	Icc2N	$\text{CKE} \geq V_{IH(\min)}$, $\overline{\text{CS}} \geq V_{IH(\min)}$, $t_{CC} = 15\text{ns}$ Input signals are changed one time during 30ns	20					mA		
	Icc2NS	$\text{CKE} \geq V_{IH(\min)}$, $\text{CLK} \leq V_{IL(\max)}$, $t_{CC} = \infty$ Input signals are stable	10							
Active Standby Current in power-down mode	Icc3P	$\text{CKE} \leq V_{IL(\max)}$, $t_{CC} = 15\text{ns}$	7					mA		
	Icc3PS	$\text{CKE} \leq V_{IL(\max)}$, $t_{CC} = \infty$	5							
Active Standby Current in non power-down mode (One Bank Active)	Icc3N	$\text{CKE} \geq V_{IH(\min)}$, $\overline{\text{CS}} \geq V_{IH(\min)}$, $t_{CC} = 15\text{ns}$ Input signals are changed one time during 30ns	55					mA		
	Icc3NS	$\text{CKE} \geq V_{IH(\min)}$, $\text{CLK} \leq V_{IL(\max)}$, $t_{CC} = \infty$ Input signals are stable	40							
Operating Current (Burst Mode)	Icc4	$I_o = 0\text{mA}$, Page Burst All bank Activated, $t_{CCD} = t_{CCD(\min)}$	3	200	190	190	180	170	mA	2
			2	150	150	150	150	150		
Refresh Current	Icc5	$t_{RC} \geq t_{RC(\min)}$	3	195	190	190	185	165	mA	3
			2	160	160	160	160	160		
Self Refresh Current	Icc6	$\text{CKE} \leq 0.2\text{V}$	3					mA	4	
			450							uA

- Notes :**
1. Unless otherwise notes, Input level is CMOS($V_{IH}/V_{IL}=V_{DDQ}/V_{SSQ}$) in LVTTTL.
 2. Measured with outputs open.
 3. Refresh period is 64ms.
 4. K4S643232E-TC**
 5. K4S643232E-TL**

AC OPERATING TEST CONDITIONS ($V_{DD} = 3.3V \pm 0.3V$, $T_A = 0$ to $70^\circ C$)

Parameter	Value	Unit
AC input levels (V_{ih}/V_{il})	2.4/0.4	V
Input timing measurement reference level	1.4	V
Input rise and fall time	$t_r/t_f = 1/1$	ns
Output timing measurement reference level	1.4	V
Output load condition	See Fig. 2	

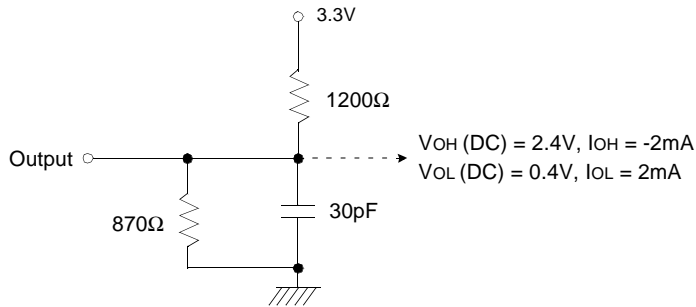

(Fig. 1) DC output load circuit

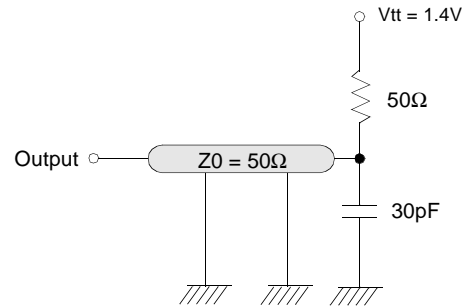

(Fig. 2) AC output load circuit

Notes : 1. The V_{DD} condition of K4S643232E-45/50/55/60 is 3.135V ~ 3.6V

OPERATING AC PARAMETER

(AC operating conditions unless otherwise noted)

Parameter	Symbol	Version										Unit	Note
		-45		-50		-55		-60		-70			
CAS Latency	CL	3	2	3	2	3	2	3	2	3	2	CLK	
CLK cycle time	$t_{CC}(\min)$	4.5	10	5	10	5.5	10	6	10	7	10	ns	
Row active to row active delay	$t_{RRD}(\min)$	2	2	2	2	2	2	2	2	2	2	CLK	1
RAS to CAS delay	$t_{RCD}(\min)$	4	2	3	2	3	2	3	2	3	2	CLK	1
Row precharge time	$t_{RP}(\min)$	4	2	3	2	3	2	3	2	3	2	CLK	1
Row active time	$t_{RAS}(\min)$	9	5	8	5	7	5	7	5	7	5	CLK	1
	$t_{RAS}(\max)$	100											
Row cycle time	$t_{RC}(\min)$	13	7	11	7	10	7	10	7	10	7	CLK	1
Last data in to row precharge	$t_{RD}(\min)$	2										CLK	2
Last data in to new col.address delay	$t_{CD}(\min)$	1										CLK	2
Last data in to burst stop	$t_{BD}(\min)$	1										CLK	2
Col. address to col. address delay	$t_{CCD}(\min)$	1										CLK	3
Mode Register Set cycle time	$t_{MRS}(\min)$	2										CLK	
Number of valid output data	CAS Latency=3	2										ea	4
	CAS Latency=2	1											

Note : 1. The minimum number of clock cycles is determined by dividing the minimum time required with clock cycle time and then rounding off to the next higher integer. Refer to the following ns-unit based AC table.

Parameter	Symbol	Version					Unit
		-45	-50	-55	-60	-70	
Row active to row active delay	tRRD(min)	9	10	11	12	14	ns
RAS to CAS delay	tRCD(min)	18	15	16.5	18	20	ns
Row precharge time	tRP(min)	18	15	16.5	18	20	ns
Row active time	tRAS(min)	40.5	40	38.5	42	49	ns
	tRAS(max)	100					us
Row cycle time	tRC(min)	58.5	55	55	60	70	ns

2. Minimum delay is required to complete write.
3. All parts allow every cycle column address change.
4. In case of row precharge interrupt, auto precharge and read burst stop.

AC CHARACTERISTICS (AC operating conditions unless otherwise noted)

Parameter		Symbol	-45		-50		-55		-60		-70		Unit	Note
			Min	Max	Min	Max	Min	Max	Min	Max	Min	Max		
CLK cycle time	CAS Latency=3	tCC	4.5	1000	5	1000	5.5	1000	6	1000	7	1000	ns	1
	CAS Latency=2		10		10		10		10		10			
CLK to valid output delay	CAS Latency=3	tSAC	-	4.0	-	4.5	-	5.0	-	5.5	-	5.5	ns	1, 2
	CAS Latency=2		-	6	-	6	-	6	-	6	-	6		
Output data hold time		tOH	2	-	2	-	2	-	2	-	2	-	ns	2
CLK high pulse width	CAS Latency=3	tCH	1.75	-	2	-	2	-	2.5	-	3	-	ns	3
	CAS Latency=2		3	-	3	-	3	-	3	-	3	-		
CLK low pulse width	CAS Latency=3	tCL	1.75	-	2	-	2	-	2.5	-	3	-	ns	3
	CAS Latency=2		3	-	3	-	3	-	3	-	3	-		
Input setup time	CAS Latency=3	tSS	1.2	-	1.5	-	1.5	-	1.5	-	1.75	-	ns	3
	CAS Latency=2		2.5	-	2.5	-	2.5	-	2.5	-	2.5	-		
Input hold time		tSH	1	-	1	-	1	-	1	-	1	-	ns	3
CLK to output in Low-Z		tSLZ	1	-	1	-	1	-	1	-	1	-	ns	2
CLK to output in Hi-Z	CAS latency=3	tSHZ	-	4.0	-	4.5	-	5.0	-	5.5	-	5.5	ns	-
	CAS latency=2		-	6	-	6	-	6	-	6	-	6		

- Note :**
1. Parameters depend on programmed CAS latency.
 2. If clock rising time is longer than 1ns, $(tr/2-0.5)ns$ should be added to the parameter.
 3. Assumed input rise and fall time $(tr \ \& \ tf)=1ns$.
If $tr \ \& \ tf$ is longer than 1ns, transient time compensation should be considered, i.e., $[(tr + tf)/2-1]ns$ should be added to the parameter.

SIMPLIFIED TRUTH TABLE

Command		CKEn-1	CKEn	\overline{CS}	\overline{RAS}	\overline{CAS}	\overline{WE}	DQM	BA0,1	A10/AP	A9 ~ A0	Note
Register	Mode register set	H	X	L	L	L	L	X	OP code			1,2
Refresh	Auto refresh	H	H	L	L	L	H	X	X			3
			L									3
	Self refresh	L	H	L	H	H	H	X	X			3
				H	X	X	X					3
Bank active & row addr.		H	X	L	L	H	H	X	V	Row address		
Read & column address	Auto precharge disable	H	X	L	H	L	H	X	V	L	Column address (A0 ~ A7)	4
	Auto precharge enable									H		4,5
Write & column address	Auto precharge disable	H	X	L	H	L	L	X	V	L	Column address (A0 ~ A7)	4
	Auto precharge enable									H		4,5
Burst Stop		H	X	L	H	H	L	X	X			6
Precharge	Bank selection	H	X	L	L	H	L	X	V	L	X	
	All banks								X	H		
Clock suspend or active power down	Entry	H	L	H	X	X	X	X	X			
				L	V	V	V					
	Exit	L	H	X	X	X	X	X	X			
Precharge power down mode	Entry	H	L	H	X	X	X	X	X			
				L	H	H	H					
	Exit	L	H	H	X	X	X	X	X			
				L	V	V	V					
DQM		H	X					V	X		7	
No operation command		H	X	H	X	X	X	X	X			
				L	H	H	H					

(V=Valid, X=Don't care, H=Logic high, L=Logic low)

Notes :1. OP Code : Operand code

A0 ~ A10 & BA0 ~ BA1 : Program keys. (@ MRS)

2. MRS can be issued only at all banks precharge state.

A new command can be issued after 2 CLK cycles of MRS.

3. Auto refresh functions are as same as CBR refresh of DRAM.

The automatic precharge without row precharge command is meant by "Auto".

Auto/self refresh can be issued only at all banks precharge state.

4. BA0 ~ BA1 : Bank select addresses.

If both BA0 and BA1 are "Low" at read, write, row active and precharge, bank A is selected.

If both BA0 is "Low" and BA1 is "High" at read, write, row active and precharge, bank B is selected.

If both BA0 is "High" and BA1 is "Low" at read, write, row active and precharge, bank C is selected.

If both BA0 and BA1 are "High" at read, write, row active and precharge, bank D is selected.

If A10/AP is "High" at row precharge, BA0 and BA1 is ignored and all banks are selected.

5. During burst read or write with auto precharge, new read/write command can not be issued.

Another bank read/write command can be issued after the end of burst.

New row active of the associated bank can be issued at tRP after the end of burst.

6. Burst stop command is valid at every burst length.

7. DQM sampled at positive going edge of a CLK and masks the data-in at the very CLK (Write DQM latency is 0), but makes Hi-Z state the data-out of 2 CLK cycles after. (Read DQM latency is 2)

MODE REGISTER FIELD TABLE TO PROGRAM MODES

Register Programmed with MRS

Address	BA0 ~ BA1	A10/AP	A9	A8	A7	A6	A5	A4	A3	A2	A1	A0
Function	RFU	RFU	W.B.L	TM		CAS Latency			BT	Burst Length		

Test Mode			CAS Latency				Burst Type		Burst Length				
A8	A7	Type	A6	A5	A4	Latency	A3	Type	A2	A1	A0	BT = 0	BT = 1
0	0	Mode Register Set	0	0	0	Reserved	0	Sequential	0	0	0	1	1
0	1	Reserved	0	0	1	Reserved	1	Interleave	0	0	1	2	2
1	0	Reserved	0	1	0	2			0	1	0	4	4
1	1	Reserved	0	1	1	3			0	1	1	8	8
Write Burst Length			1	0	0	Reserved			1	0	0	Reserved	Reserved
A9	Length		1	0	1	Reserved			1	0	1	Reserved	Reserved
0	Burst		1	1	0	Reserved			1	1	0	Reserved	Reserved
1	Single Bit		1	1	1	Reserved			1	1	1	Full Page	Reserved

Full Page Length : x32 (256)

POWER UP SEQUENCE

SDRAMs must be powered up and initialized in a predefined manner to prevent undefined operations.

1. Apply power and start clock. Must maintain CKE= "H", DQM= "H" and the other pins are NOP condition at the inputs.
2. Maintain stable power, stable clock and NOP input condition for a minimum of 200us.
3. Issue precharge commands for all banks of the devices.
4. Issue 2 or more auto-refresh commands.
5. Issue a mode register set command to initialize the mode register.
cf.) Sequence of 4 & 5 is regardless of the order.

The device is now ready for normal operation.

- Note :**
1. If A9 is high during MRS cycle, "Burst Read Single Bit Write" function will be enabled.
 2. RFU (Reserved for future use) should stay "0" during MRS cycle.

BURST SEQUENCE (BURST LENGTH = 4)

Initial Address		Sequential				Interleave			
A1	A0								
0	0	0	1	2	3	0	1	2	3
0	1	1	2	3	0	1	0	3	2
1	0	2	3	0	1	2	3	0	1
1	1	3	0	1	2	3	2	1	0

BURST SEQUENCE (BURST LENGTH = 8)

Initial Address			Sequential								Interleave								
A2	A1	A0																	
0	0	0	0	1	2	3	4	5	6	7	0	1	2	3	4	5	6	7	
0	0	1	1	2	3	4	5	6	7	0	1	0	3	2	5	4	7	6	
0	1	0	2	3	4	5	6	7	0	1	2	3	0	1	6	7	4	5	
0	1	1	3	4	5	6	7	0	1	2	3	2	1	0	7	6	5	4	
1	0	0	4	5	6	7	0	1	2	3	4	5	6	7	0	1	2	3	
1	0	1	5	6	7	0	1	2	3	4	5	4	7	6	1	0	3	2	
1	1	0	6	7	0	1	2	3	4	5	6	7	4	5	2	3	0	1	
1	1	1	7	0	1	2	3	4	5	6	7	6	5	4	3	2	1	0	