

N-CHANNEL SILICON POWER MOSFET

FAP-IIA SERIES

Features

- High speed switching
- Low on-resistance
- No secondary breakdown
- Low driving power
- High voltage
- V_{GS}=±30V Guarantee
- Avalanche-proof

Applications

- Switching regulators
- UPS
- DC-DC converters
- General purpose power amplifier

Maximum ratings and characteristics

Absolute maximum ratings (T_c=25°C unless otherwise specified)

Item	Symbol	Rating	Unit
Drain-source voltage	V _{DS}	600	V
Continuous drain current	I _D	16	A
Pulsed drain current	I _{D(puls)}	64	A
Continuous reverse drain current	I _{DR}	16	A
Gate-source peak voltage	V _{GS}	±30	V
Max. power dissipation	P _D	100	W
Operating and storage temperature range	T _{ch}	+150	°C
	T _{stg}	-55 to +150	°C

Electrical characteristics (T_c =25°C unless otherwise specified)

Item	Symbol	Test Conditions	Min.	Typ.	Max.	Units
Drain-source breakdown voltage	V _{(BR)DSS}	I _D =1mA V _{GS} =0V	600			V
Gate threshold voltage	V _{GS(th)}	I _D =1mA V _{DS} =V _{GS}	2.5	3.0	3.5	V
Zero gate voltage drain current	I _{DSS}	V _{DS} =600V V _{GS} =0V	T _{ch} =25°C	10	500	μA
			T _{ch} =125°C		0.2	1.0
Gate-source leakage current	I _{GSS}	V _{GS} =±30V V _{DS} =0V		10	100	nA
Drain-source on-state resistance	R _{DS(on)}	I _D =8A V _{GS} =10V		0.37	0.55	Ω
Forward transconductance	g _{fs}	I _D =8A V _{DS} =25V	9.0	18.0		S
Input capacitance	C _{iss}	V _{DS} =25V		3300	4950	pF
Output capacitance	C _{oss}	V _{GS} =0V		310	470	
Reverse transfer capacitance	C _{rss}	f=1MHz		70	110	
Turn-on time t _{on} (t _{on} =t _{d(on)} +t _r)	t _{d(on)}	V _{CC} =300V R _G =10 Ω		35	55	ns
	t _r	I _D =16A		70	110	
Turn-off time t _{off} (t _{off} =t _{d(off)} +t _f)	t _{d(off)}	V _{GS} =10V		180	270	
	t _f			100	150	
Avalanche capability	I _{AV}	L=100μH T _{ch} =25°C	16			A
Diode forward on-voltage	V _{SD}	I _F =2xI _{DR} V _{GS} =0V T _{ch} =25°C		1.0	1.5	V
Reverse recovery time	t _{rr}	I _F =I _{DR} V _{GS} =0V -di/dt=100A/μs T _{ch} =25°C		500		ns

Thermal characteristics

Item	Symbol	Test Conditions	Min.	Typ.	Max.	Units
Thermal resistance	R _{th(ch-a)}	channel to ambient			30.0	°C/W
	R _{th(ch-c)}	channel to case			1.25	°C/W

Outline Drawings

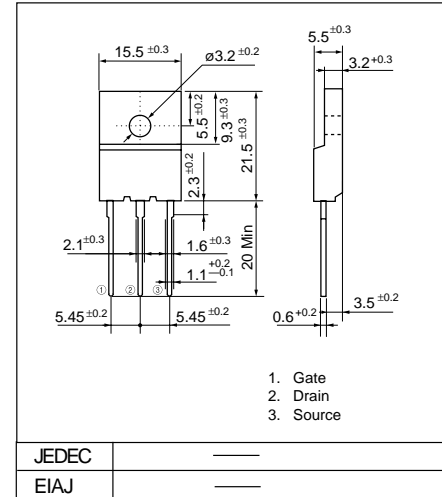

Equivalent circuit schematic

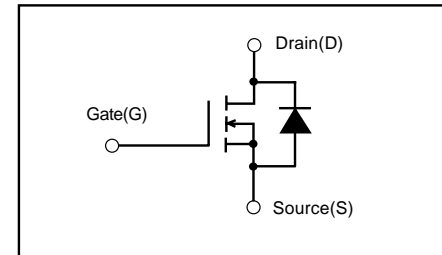

Characteristics

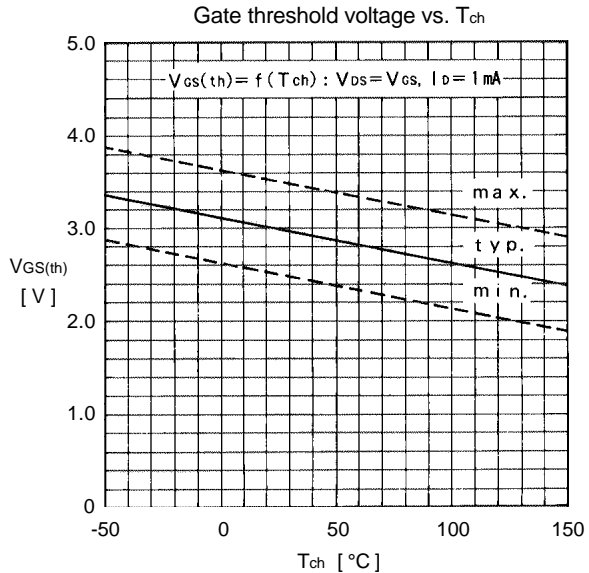
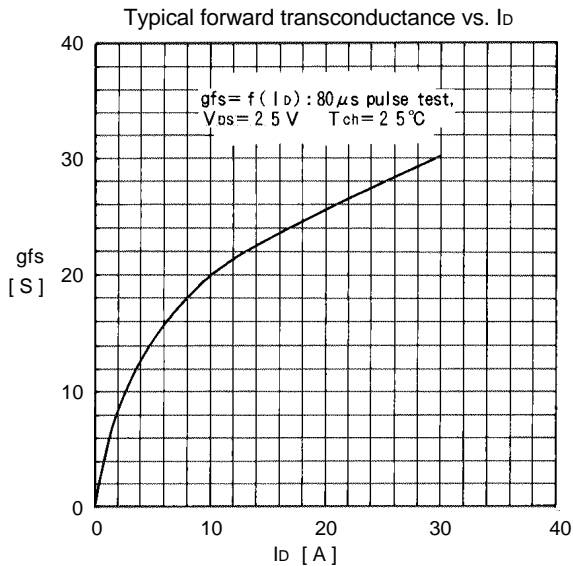
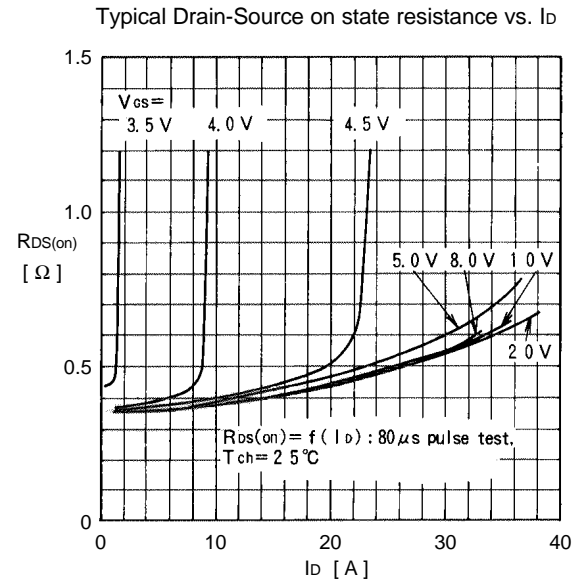
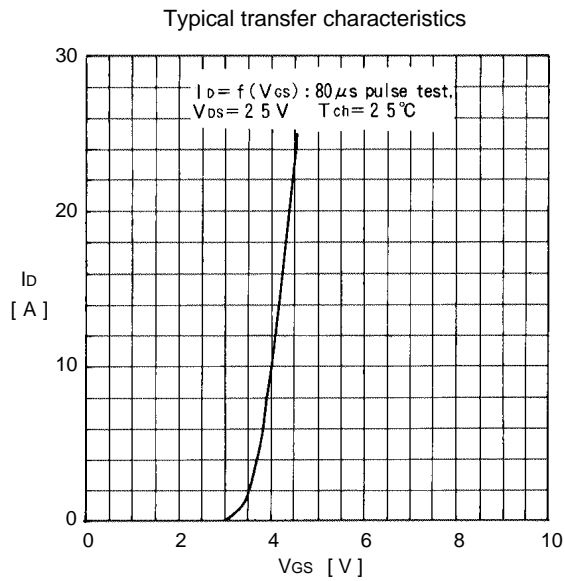
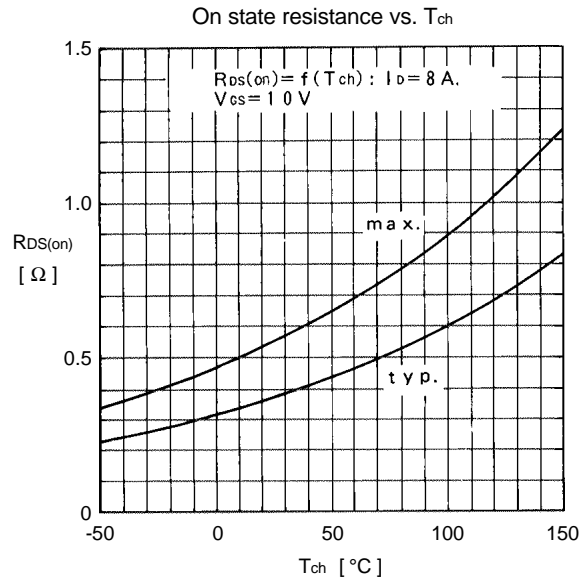
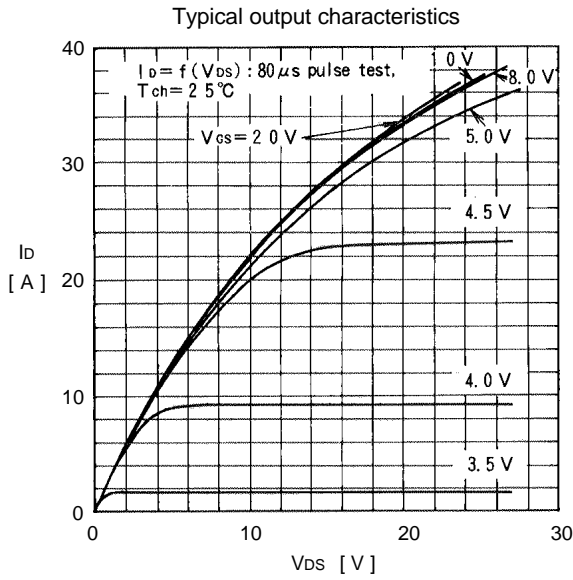

Typical capacitance vs. V_{DS}

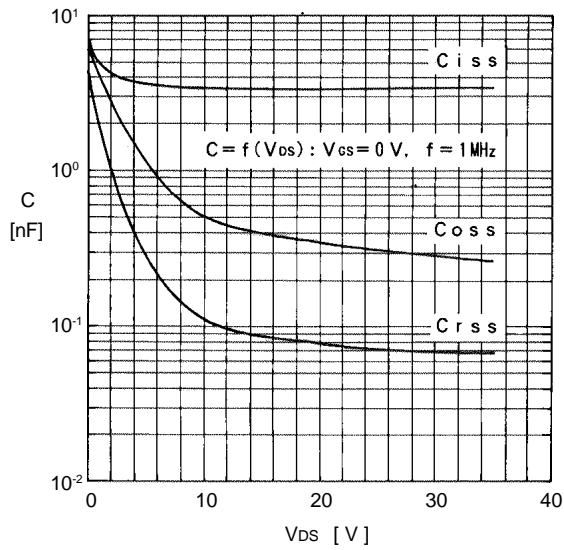

Typical input charge

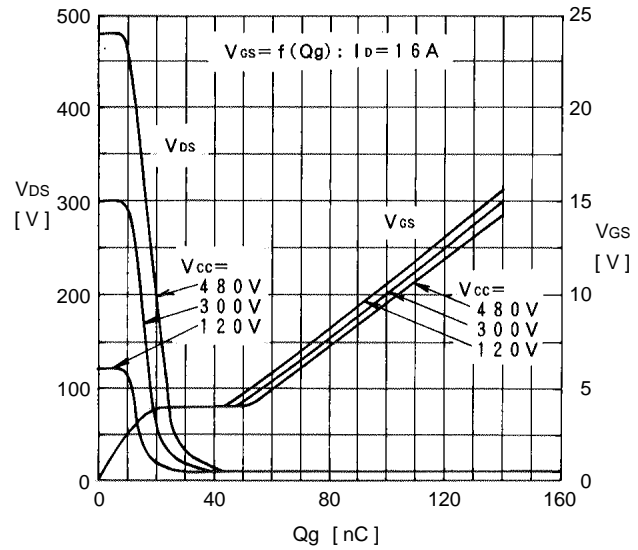

Forward characteristics of reverse diode

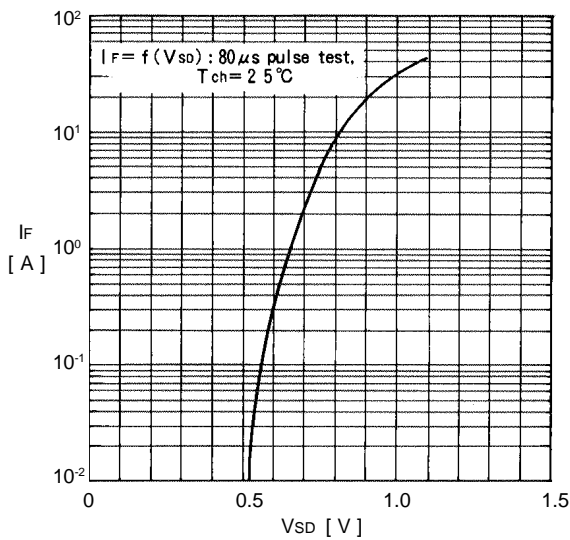

Allowable power dissipation vs. T_c

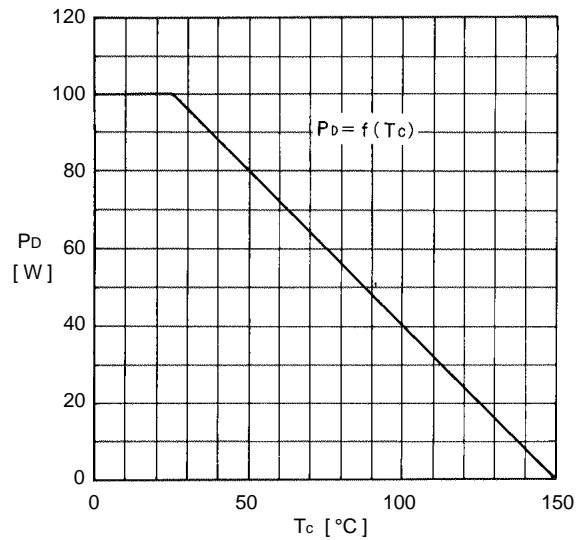

Safe operating area

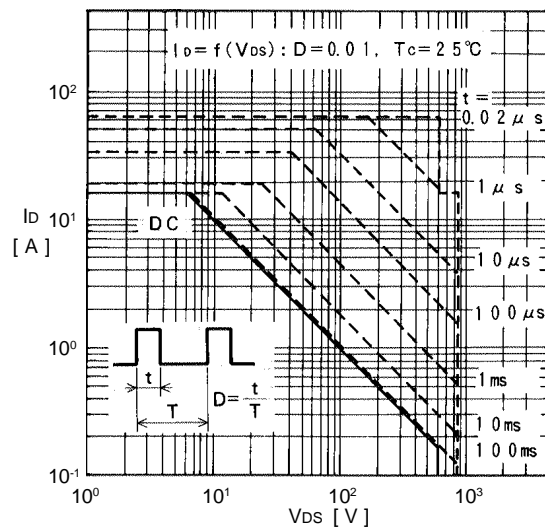

Transient thermal impedance

