



MACH110-12/15/20

High-Density EE CMOS Programmable Logic

DISTINCTIVE CHARACTERISTICS

- 44 Pins
- 32 Macrocells
- 12 ns t_{PD} Commercial
14 ns t_{PD} Industrial
- 77 MHz f_{CNT}
- 38 Inputs
- 32 Outputs
- 32 Flip-flops; 2 clock choices
- 2 "PAL22V16" Blocks
- Pin-compatible with MACH111, MACH210, MACH211, MACH215

GENERAL DESCRIPTION

The MACH110 is a member of AMD's high-performance EE CMOS MACH 1 family. This device has approximately three times the logic macrocell capability of the popular PAL22V10 without loss of speed.

The MACH110 consists of two PAL blocks interconnected by a programmable switch matrix. The two PAL blocks are essentially "PAL22V16" structures complete with product-term arrays and programmable macrocells. The switch matrix connects the PAL blocks to each other and to all input pins, providing a high degree of connectivity between the fully-connected PAL blocks. This allows designs to be placed and routed efficiently.

The MACH110 macrocell provides either registered or combinatorial outputs with programmable polarity. If a registered configuration is chosen, the register can be configured as D-type or T-type to help reduce the number of product terms. The register type decision can be made by the designer or by the software. All macrocells can be connected to an I/O cell. If a buried macrocell is desired, the internal feedback path from the macrocell can be used, which frees up the I/O pin for use as an input.

BLOCK DIAGRAM

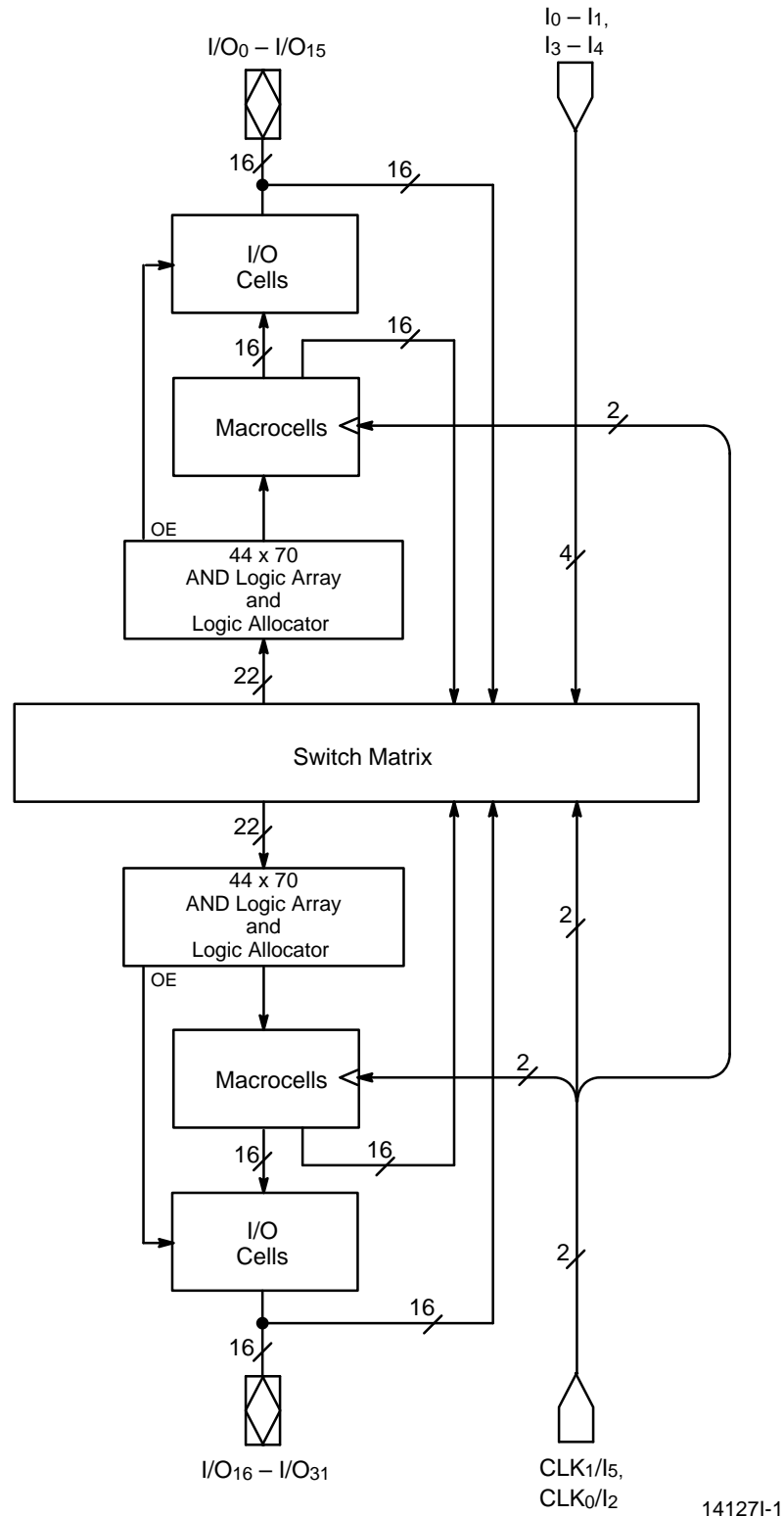

141271-1

CONNECTION DIAGRAM
Top View

PLCC

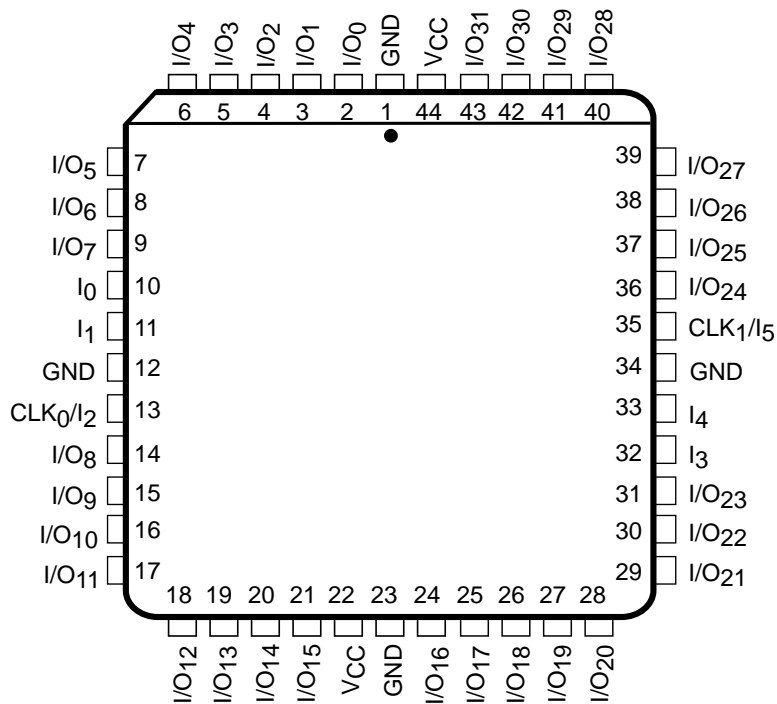

141271-2

Note:
Pin-compatible with MACH111, MACH210, MACH211, and MACH215.

PIN DESIGNATIONS

- CLK/I = Clock or Input
- GND = Ground
- I = Input
- I/O = Input/Output
- V_{CC} = Supply Voltage

ORDERING INFORMATION

Commercial Products

AMD programmable logic products for commercial applications are available with several ordering options. The order number (Valid Combination) is formed by a combination of:

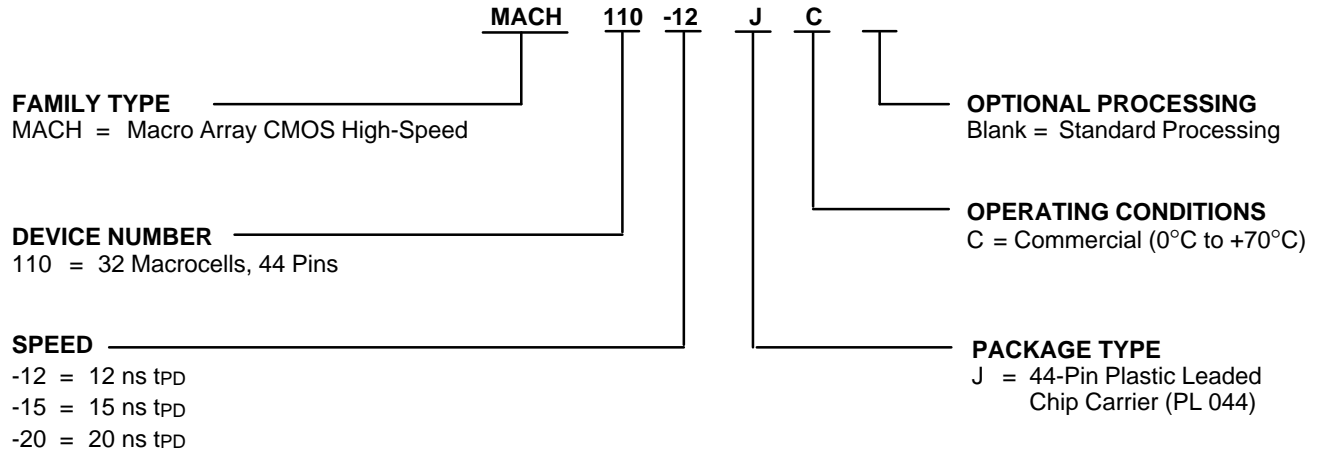

Valid Combinations	
MACH110-12	JC
MACH110-15	
MACH110-20	

Valid Combinations

The Valid Combinations table lists configurations planned to be supported in volume for this device. Consult the local AMD sales office to confirm availability of specific valid combinations and to check on newly released combinations.

ORDERING INFORMATION

Industrial Products

AMD programmable logic products for Industrial applications are available with several ordering options. The order number (Valid Combination) is formed by a combination of:

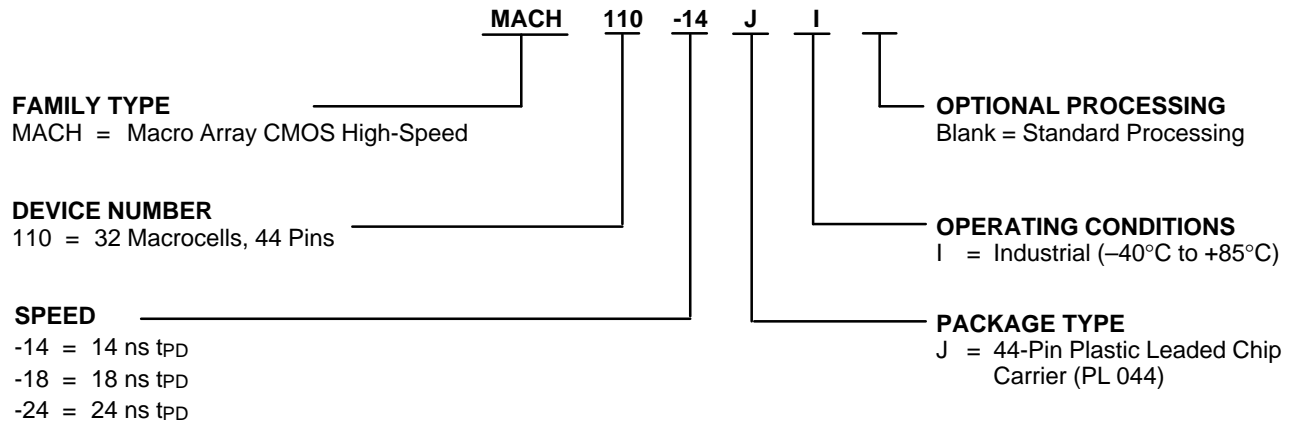

Valid Combinations	
MACH110-14	JI
MACH110-18	
MACH110-24	

Valid Combinations

The Valid Combinations table lists configurations planned to be supported in volume for this device. Consult the local AMD sales office to confirm availability of specific valid combinations and to check on newly released combinations.

FUNCTIONAL DESCRIPTION

The MACH110 consists of two PAL blocks connected by a switch matrix. There are 32 I/O pins and 6 dedicated input pins feeding the switch matrix. These signals are distributed to the two PAL blocks for efficient design implementation. There are two clock pins that can also be used as dedicated inputs.

The PAL Blocks

Each PAL block in the MACH110 (Figure 1) contains a 64-product-term logic array, a logic allocator, 16 macrocells and 16 I/O cells. The switch matrix feeds each PAL block with 22 inputs. This makes the PAL block look effectively like an independent “PAL22V16”.

There are four additional output enable product terms in each PAL block. For purposes of output enable, the 16 I/O cells are divided into 2 banks of 8 macrocells. Each bank is allocated two of the output enable product terms.

An asynchronous reset product term and an asynchronous preset product term are provided for flip-flop initialization. All flip-flops within the PAL block are initialized together.

The Switch Matrix

The MACH110 switch matrix is fed by the inputs and feedback signals from the PAL blocks. Each PAL block provides 16 internal feedback signals and 16 I/O feedback signals. The switch matrix distributes these signals back to the PAL blocks in an efficient manner that also provides for high performance. The design software automatically configures the switch matrix when fitting a design into the device.

The Product-Term Array

The MACH110 product-term array consists of 64 product terms for logic use, and 6 special-purpose product terms. Four of the special-purpose product terms provide programmable output enable, one provides asynchronous reset, and one provides a synchronous preset. Two of the output enable product terms are used for the first eight I/O cells; the other two control the last eight macrocells.

The Logic Allocator

The logic allocator in the MACH110 takes the 64 logic product terms and allocates them to the 16 macrocells as needed. Each macrocell can be driven by up to 12 product terms. The design software automatically configures the logic allocator when fitting the design into the device.

Table 1 illustrates which product term clusters are available to each macrocell within a PAL block. Refer to Figure 1 for cluster and macrocell numbers.

Table 1. Logic Allocation

Output Macrocell	Available Clusters
M ₀	C ₀ , C ₁
M ₁	C ₀ , C ₁ , C ₂
M ₂	C ₁ , C ₂ , C ₃
M ₃	C ₂ , C ₃ , C ₄
M ₄	C ₃ , C ₄ , C ₅
M ₅	C ₄ , C ₅ , C ₆
M ₆	C ₅ , C ₆ , C ₇
M ₇	C ₆ , C ₇
M ₈	C ₈ , C ₉
M ₉	C ₈ , C ₉ , C ₁₀
M ₁₀	C ₉ , C ₁₀ , C ₁₁
M ₁₁	C ₁₀ , C ₁₁ , C ₁₂
M ₁₂	C ₁₁ , C ₁₂ , C ₁₃
M ₁₃	C ₁₂ , C ₁₃ , C ₁₄
M ₁₄	C ₁₃ , C ₁₄ , C ₁₅
M ₁₅	C ₁₄ , C ₁₅

The Macrocell

The MACH110 macrocells can be configured as either registered or combinatorial, with programmable polarity. The macrocell provides internal feedback whether configured as registered or combinatorial. The flip-flops can be configured as D-type or T-type, allowing for product-term optimization.

The flip-flops can individually select one of two clock pins, which are also available as data inputs. The registers are clocked on the LOW-to-HIGH transition of the clock signal. The flip-flops can also be asynchronously initialized with the common asynchronous reset and preset product terms.

The I/O Cell

The I/O cell in the MACH110 consists of a three-state output buffer. The three-state buffer can be configured in one of three ways: always enabled, always disabled, or controlled by a product term. If product term control is chosen, one of two product terms may be used to provide the control. The two product terms that are available are common to eight I/O cells. Within each PAL block, two product terms are available for selection by the first eight three-state outputs; two other product terms are available for selection by the last eight three-state outputs.

These choices make it possible to use the macrocell as an output, an input, a bidirectional pin, or a three-state output for use in driving a bus.

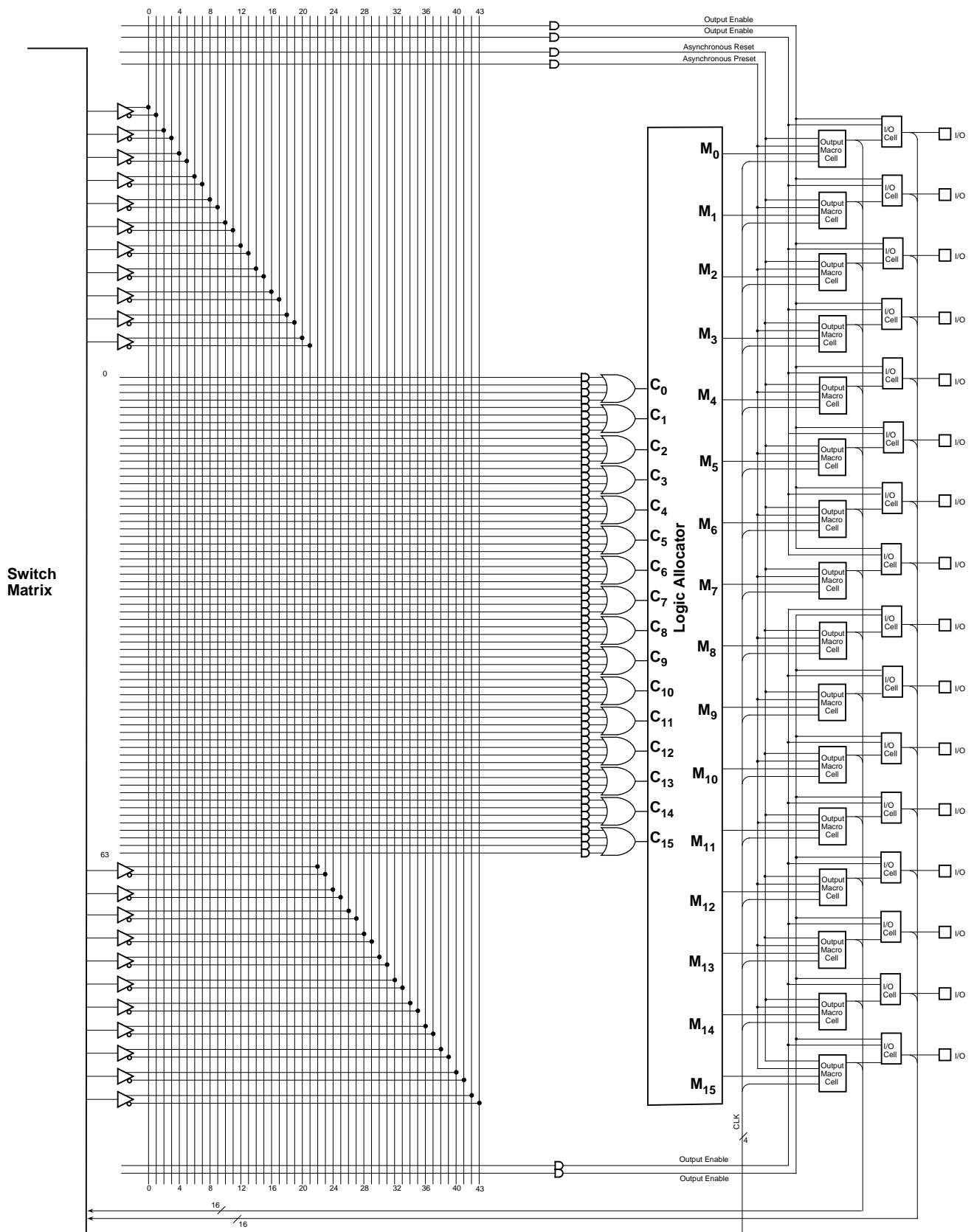

141271-3

Figure 1. MACH110 PAL Block

ABSOLUTE MAXIMUM RATINGS

Storage Temperature	−65°C to +150°C
Ambient Temperature	
With Power Applied	−55°C to +125°C
Supply Voltage with Respect to Ground	−0.5 V to +7.0 V
DC Input Voltage	−0.5 V to $V_{CC} + 0.5$ V
DC Output or I/O Pin Voltage	−0.5 V to $V_{CC} + 0.5$ V
Static Discharge Voltage	2001 V
Latchup Current ($T_A = 0^\circ\text{C}$ to 70°C)	200 mA

Stresses above those listed under Absolute Maximum Ratings may cause permanent device failure. Functionality at or above these limits is not implied. Exposure to Absolute Maximum Ratings for extended periods may affect device reliability. Programming conditions may differ.

OPERATING RANGES

Commercial (C) Devices

Ambient Temperature (T_A)	
Operating in Free Air	0°C to +70°C
Supply Voltage (V_{CC})	
with Respect to Ground	+4.75 V to +5.25 V

Operating ranges define those limits between which the functionality of the device is guaranteed.

DC CHARACTERISTICS over COMMERCIAL operating ranges unless otherwise specified

Parameter Symbol	Parameter Description	Test Conditions	Min	Typ	Max	Unit
V_{OH}	Output HIGH Voltage	$I_{OH} = -3.2$ mA, $V_{CC} = \text{Min}$ $V_{IN} = V_{IH}$ or V_{IL}	2.4			V
V_{OL}	Output LOW Voltage	$I_{OL} = 16$ mA, $V_{CC} = \text{Min}$ $V_{IN} = V_{IH}$ or V_{IL}			0.5	V
V_{IH}	Input HIGH Voltage	Guaranteed Input Logical HIGH Voltage for all Inputs (Note 1)	2.0			V
V_{IL}	Input LOW Voltage	Guaranteed Input Logical LOW Voltage for all Inputs (Note 1)			0.8	V
I_{IH}	Input HIGH Current	$V_{IN} = 5.25$ V, $V_{CC} = \text{Max}$ (Note 2)			10	μA
I_{IL}	Input LOW Current	$V_{IN} = 0$ V, $V_{CC} = \text{Max}$ (Note 2)			−10	μA
I_{OZH}	Off-State Output Leakage Current HIGH	$V_{OUT} = 5.25$ V, $V_{CC} = \text{Max}$ $V_{IN} = V_{IH}$ or V_{IL} (Note 2)			10	μA
I_{OLZ}	Off-State Output Leakage Current LOW	$V_{OUT} = 0$ V, $V_{CC} = \text{Max}$ $V_{IN} = V_{IH}$ or V_{IL} (Note 2)			−10	μA
I_{SC}	Output Short-Circuit Current	$V_{OUT} = 0.5$ V, $V_{CC} = \text{Max}$ (Note 3)	−30		−160	mA
I_{CC}	Supply Current (Typical)	$V_{CC} = 5$ V, $T_A = 25^\circ\text{C}$, $f = 25$ MHz (Note 4)		95		mA

Notes:

- These are absolute values with respect to device ground and all overshoots due to system and/or tester noise are included.
- I/O pin leakage is the worst case of I_{IL} and I_{OLZ} (or I_{IH} and I_{OZH}).
- Not more than one output should be shorted at a time. Duration of the short-circuit should not exceed one second. $V_{OUT} = 0.5$ V has been chosen to avoid test problems caused by tester ground degradation.
- Measured with a 16-bit up/down counter program. This pattern is programmed in each PAL block and is capable of being loaded, enabled, and reset.

CAPACITANCE (Note 1)

Parameter Symbol	Parameter Description	Test Conditions		Typ	Unit
C _{IN}	Input Capacitance	V _{IN} = 2.0 V	V _{CC} = 5.0 V, T _A = 25°C	6	pF
C _{OUT}	Output Capacitance	V _{OUT} = 2.0 V		f = 1 MHz	8

SWITCHING CHARACTERISTICS over COMMERCIAL operating ranges (Note 2)

Parameter Symbol	Parameter Description		-12		-15		-20		Unit	
			Min	Max	Min	Max	Min	Max		
t _{PD}	Input, I/O, or Feedback to Combinatorial Output (Note 3)			12		15		20	ns	
t _s	Setup Time from Input, I/O, or Feedback to Clock	D-type	7		10		13		ns	
		T-type	8		11		14		ns	
t _H	Hold Time		0		0		0		ns	
t _{CO}	Clock to Output (Note 3)			8		10		12	ns	
t _{WL}	Clock Width		LOW	6		6		8	ns	
t _{WH}			HIGH	6		6		8	ns	
f _{MAX}	Maximum Frequency (Note 1)	External Feedback	1/(t _s + t _{CO})		D-type	66.7		50		MHz
			T-type	62.5		47.6		38.5		MHz
		Internal Feedback (f _{CNT})	D-type	76.9		66.6		47.6		MHz
			T-type	71.4		55.5		43.5		MHz
No Feedback	1/(t _{WL} + t _{WH})		83.3		83.3		62.5		MHz	
t _{AR}	Asynchronous Reset to Registered Output			16		20		25	ns	
t _{ARW}	Asynchronous Reset Width (Note 1)		12		15		20		ns	
t _{ARR}	Asynchronous Reset Recovery Time (Note 1)		8		10		15		ns	
t _{AP}	Asynchronous Preset to Registered Output			16		20		25	ns	
t _{APW}	Asynchronous Preset Width (Note 1)		12		15		20		ns	
t _{APR}	Asynchronous Preset Recovery Time (Note 1)		8		10		15		ns	
t _{EA}	Input, I/O, or Feedback to Output Enable (Note 3)			12		15		20	ns	
t _{ER}	Input, I/O, or Feedback to Output Disable (Note 3)			12		15		20	ns	

Notes:

1. These parameters are not 100% tested, but are evaluated at initial characterization and at any time the design is modified where capacitance may be affected.
2. See Switching Test Circuit, for test conditions.
3. Parameters measured with 16 outputs switching.

ABSOLUTE MAXIMUM RATINGS

Storage Temperature	−65°C to +150°C
Ambient Temperature	
With Power Applied	−55°C to +125°C
Supply Voltage with Respect to Ground	−0.5 V to +7.0 V
DC Input Voltage	−0.5 V to $V_{CC} + 0.5$ V
DC Output or I/O Pin Voltage	−0.5 V to $V_{CC} + 0.5$ V
Static Discharge Voltage	2001 V
Latchup Current ($T_A = -40^\circ\text{C}$ to $+85^\circ\text{C}$)	200 mA

Stresses above those listed under Absolute Maximum Ratings may cause permanent device failure. Functionality at or above these limits is not implied. Exposure to Absolute Maximum Ratings for extended periods may affect device reliability. Programming conditions may differ.

INDUSTRIAL OPERATING RANGES

Ambient Temperature (T_A)	
Operating in Free Air	−40°C to +85°C
Supply Voltage (V_{CC}) with Respect to Ground	+4.5 V to +5.5 V

Operating ranges define those limits between which the functionality of the device is guaranteed.

DC CHARACTERISTICS over INDUSTRIAL operating ranges unless otherwise specified

Parameter Symbol	Parameter Description	Test Conditions	Min	Typ	Max	Unit
V_{OH}	Output HIGH Voltage	$I_{OH} = -3.2$ mA, $V_{CC} = \text{Min}$ $V_{IN} = V_{IH}$ or V_{IL}	2.4			V
V_{OL}	Output LOW Voltage	$I_{OL} = 16$ mA, $V_{CC} = \text{Min}$ $V_{IN} = V_{IH}$ or V_{IL}			0.5	V
V_{IH}	Input HIGH Voltage	Guaranteed Input Logical HIGH Voltage for all Inputs (Note 1)	2.0			V
V_{IL}	Input LOW Voltage	Guaranteed Input Logical LOW Voltage for all Inputs (Note 1)			0.8	V
I_{IH}	Input HIGH Current	$V_{IN} = 5.25$ V, $V_{CC} = \text{Max}$ (Note 2)			10	μA
I_{IL}	Input LOW Current	$V_{IN} = 0$ V, $V_{CC} = \text{Max}$ (Note 2)			−10	μA
I_{OZH}	Off-State Output Leakage Current HIGH	$V_{OUT} = 5.25$ V, $V_{CC} = \text{Max}$ $V_{IN} = V_{IH}$ or V_{IL} (Note 2)			10	μA
I_{OZL}	Off-State Output Leakage Current LOW	$V_{OUT} = 0$ V, $V_{CC} = \text{Max}$ $V_{IN} = V_{IH}$ or V_{IL} (Note 2)			−10	μA
I_{SC}	Output Short-Circuit Current	$V_{OUT} = 0.5$ V, $V_{CC} = \text{Max}$ (Note 3)	−30		−160	mA
I_{CC}	Supply Current (Typical)	$V_{CC} = 5$ V, $T_A = 25^\circ\text{C}$, $f = 25$ MHz (Note 4)		95		mA

Notes:

- These are absolute values with respect to device ground and all overshoots due to system and/or tester noise are included.
- I/O pin leakage is the worst case of I_{IL} and I_{OZL} (or I_{IH} and I_{OZH}).
- Not more than one output should be shorted at a time. Duration of the short-circuit should not exceed one second. $V_{OUT} = 0.5$ V has been chosen to avoid test problems caused by tester ground degradation.
- Measured with a 16-bit up/down counter pattern. This pattern is programmed in each PAL block and is capable of being loaded, enabled, and reset.

CAPACITANCE (Note 1)

Parameter Symbol	Parameter Description	Test Conditions		Typ	Unit
C _{IN}	Input Capacitance	V _{IN} = 2.0 V	V _{CC} = 5.0 V, T _A = 25°C	6	pF
C _{OUT}	Output Capacitance	V _{OUT} = 2.0 V	f = 1 MHz	8	pF

SWITCHING CHARACTERISTICS over INDUSTRIAL operating ranges (Note 2)

Parameter Symbol	Parameter Description		-14		-18		-24		Unit	
			Min	Max	Min	Max	Min	Max		
t _{PD}	Input, I/O, or Feedback to Combinatorial Output (Note 3)			14.5		18		24	ns	
t _s	Setup Time from Input, I/O, or Feedback to Clock	D-type	8.5		12		16		ns	
		T-type	10		13.5		17		ns	
t _H	Hold Time		0		0		0		ns	
t _{CO}	Clock to Output (Note 3)			10		12		14.5	ns	
t _{WL}	Clock Width		LOW	7.5		7.5		10	ns	
t _{WH}			HIGH	7.5		7.5		10	ns	
f _{MAX}	Maximum Frequency (Note 1)	External Feedback	1/(t _s + t _{CO})	D-type	53.5		40		32	MHz
			T-type	50		38		30	MHz	
		Internal Feedback (f _{CNT})	D-type	61.5		53		38	MHz	
			T-type	57		44		34.5	MHz	
No Feedback	1/(t _{WL} + t _{WH})	66.5		66.5		50	MHz			
t _{AR}	Asynchronous Reset to Registered Output			19.5		24		30	ns	
t _{ARW}	Asynchronous Reset Width (Note 1)		14.5		18		24		ns	
t _{ARR}	Asynchronous Reset Recovery Time (Note 1)		10		12		18		ns	
t _{AP}	Asynchronous Preset to Registered Output			19.5		24		30	ns	
t _{APW}	Asynchronous Preset Width (Note 1)		14.5		18		24		ns	
t _{APR}	Asynchronous Preset Recovery Time (Note 1)		10		12		18		ns	
t _{EA}	Input, I/O, or Feedback to Output Enable (Note 3)			14.5		18		24	ns	
t _{ER}	Input, I/O, or Feedback to Output Disable (Note 3)			14.5		18		24	ns	

Notes:

1. These parameters are not 100% tested, but are evaluated at initial characterization and at any time the design is modified where capacitance may be affected.
2. See Switching Test Circuit, for test conditions.
3. Parameters measured with 16 outputs switching.

TYPICAL CURRENT VS. VOLTAGE (I-V) CHARACTERISTICS

$V_{CC} = 5.0\text{ V}$, $T_A = 25^\circ\text{C}$

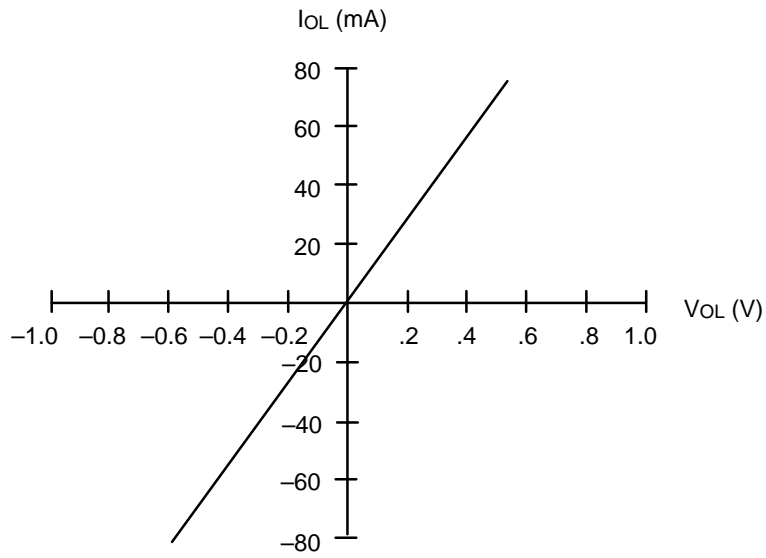

Output, LOW

141271-4

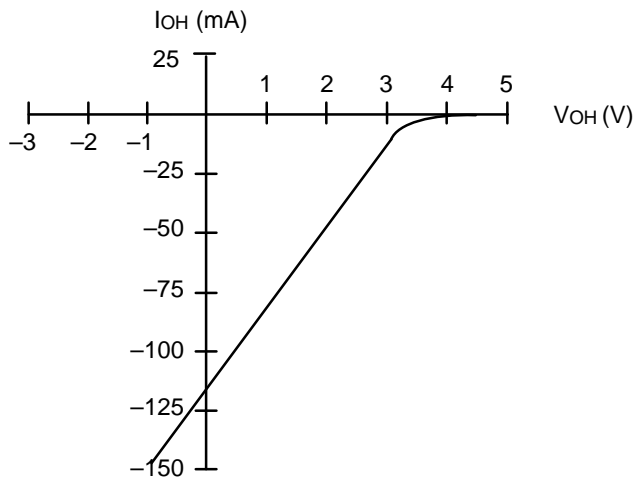

Output, HIGH

141271-5

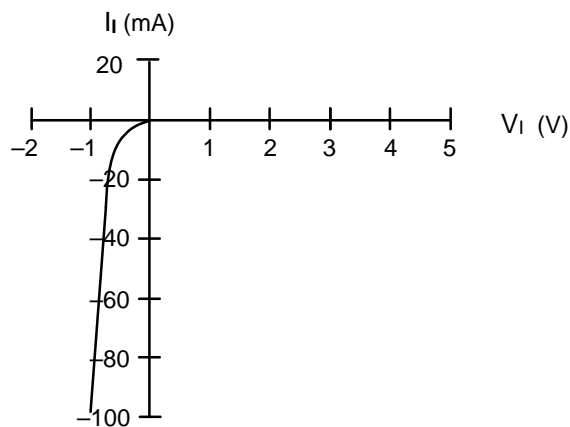

Input

141271-6

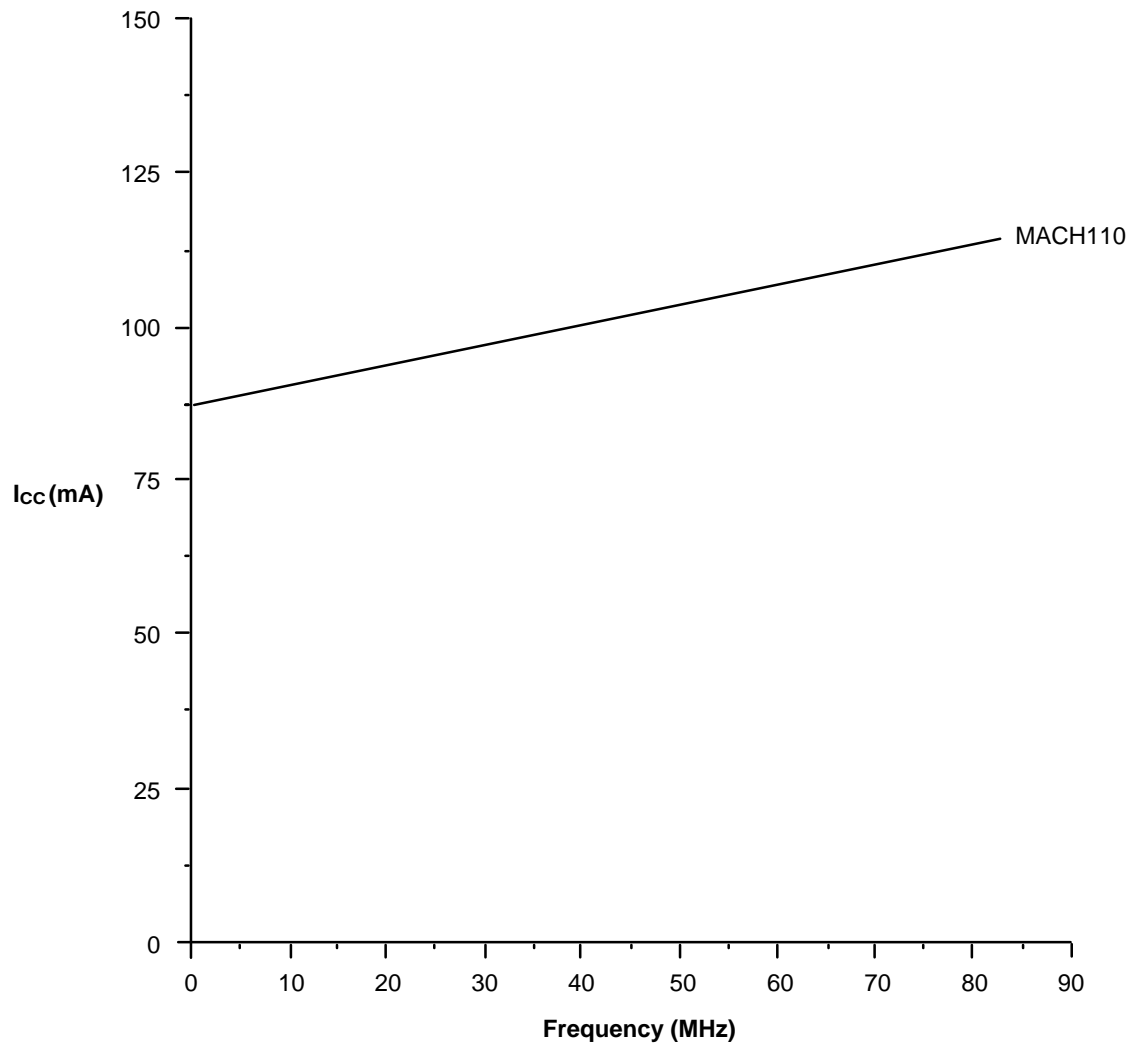
TYPICAL I_{CC} CHARACTERISTICS $V_{CC} = 5\text{ V}$, $T_A = 25^\circ\text{C}$ 

141271-7

The selected "typical" pattern is a 16-bit up/down counter. This pattern is programmed in each PAL block and is capable of being loaded, enabled, and reset.

Maximum frequency shown uses internal feedback and a D-type register.

TYPICAL THERMAL CHARACTERISTICS

Measured at 25°C ambient. These parameters are not tested.

Parameter Symbol	Parameter Description	Typ	Unit	
		PLCC		
θ_{jc}	Thermal impedance, junction to case	14	°C/W	
θ_{ja}	Thermal impedance, junction to ambient	39	°C/W	
θ_{jma}	Thermal impedance, junction to ambient with air flow	200 lfpm air	33	°C/W
		400 lfpm air	30	°C/W
		600 lfpm air	27	°C/W
		800 lfpm air	25	°C/W

Plastic θ_{jc} Considerations

The data listed for plastic θ_{jc} are for reference only and are not recommended for use in calculating junction temperatures. The heat-flow paths in plastic-encapsulated devices are complex, making the θ_{jc} measurement relative to a specific location on the package surface. Tests indicate this measurement reference point is directly below the die-attach area on the bottom center of the package. Furthermore, θ_{jc} tests on packages are performed in a constant-temperature bath, keeping the package surface at a constant temperature. Therefore, the measurements can only be used in a similar environment.

SWITCHING WAVEFORMS

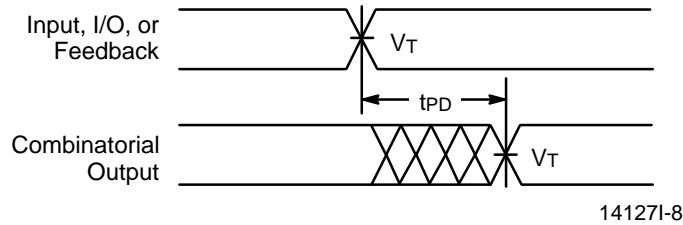

Combinatorial Output

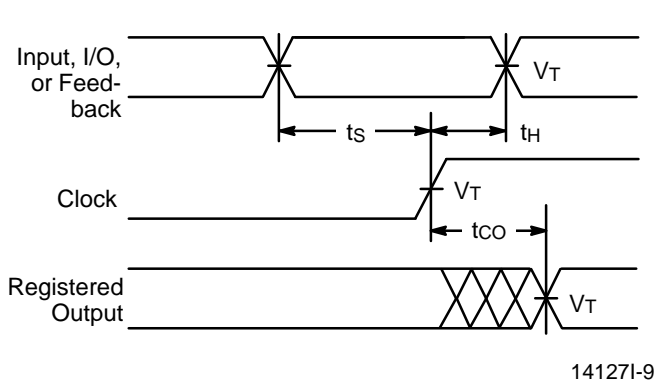

Registered Output

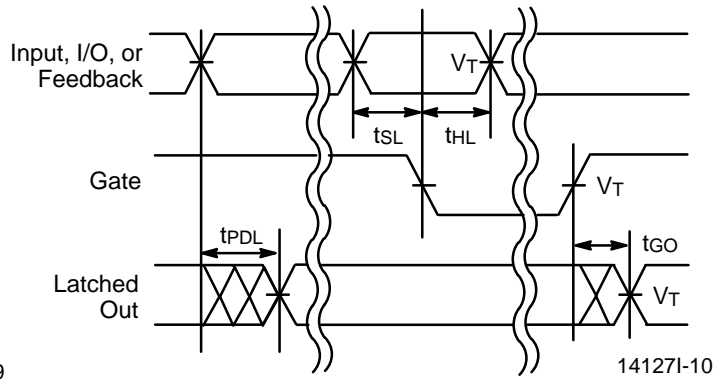

Latched Output (MACH 2, 3, and 4)

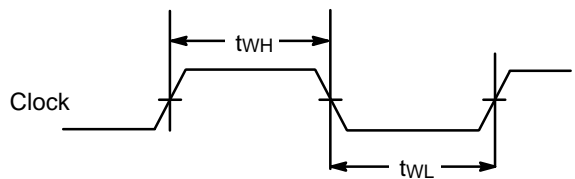

Clock Width

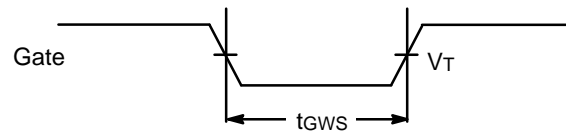

Gate Width (MACH 2, 3, and 4)

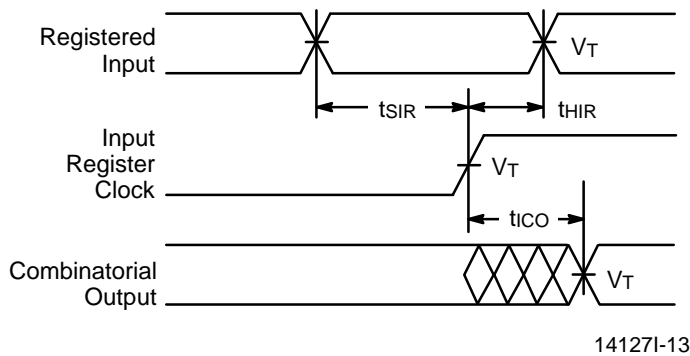

Registered Input (MACH 2 and 4)

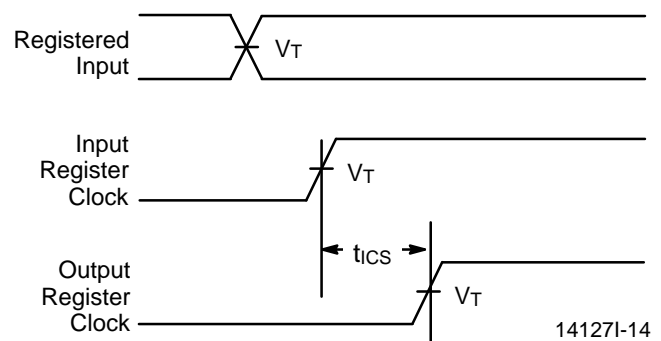

Input Register to Output Register Setup (MACH 2 and 4)

Notes:

1. $V_T = 1.5\text{ V}$.
2. Input pulse amplitude 0 V to 3.0 V.
3. Input rise and fall times 2 ns–4 ns typical.

SWITCHING WAVEFORMS

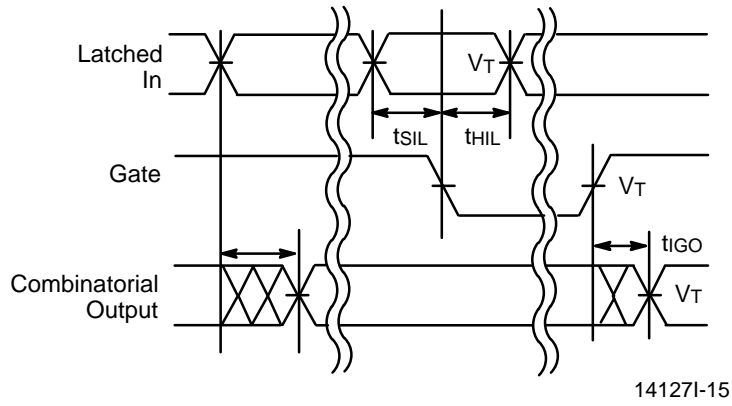

Latched Input (MACH 2 and 4)

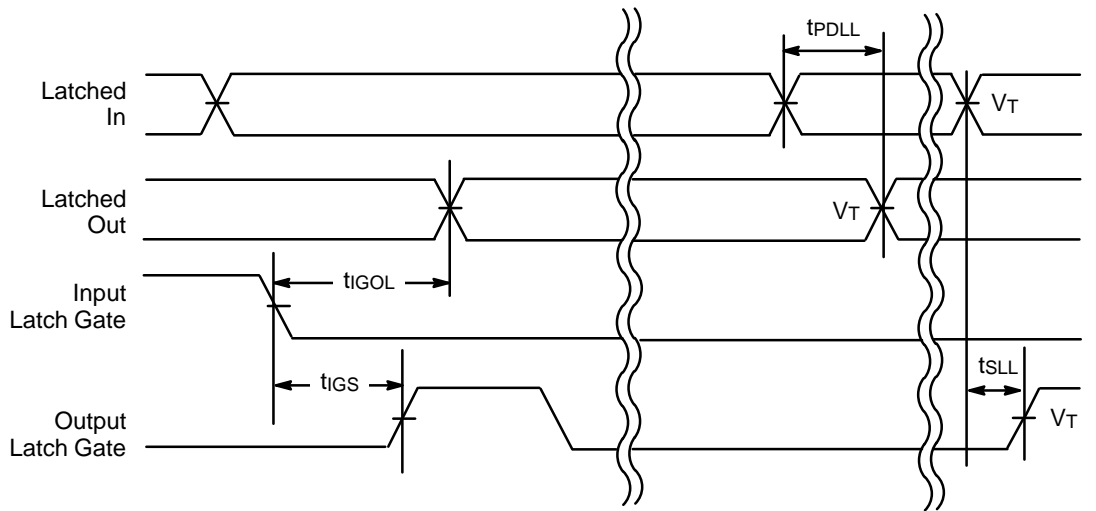

Latched Input and Output (MACH 2, 3, and 4)

Notes:

1. $V_T = 1.5\text{ V}$.
2. Input pulse amplitude 0 V to 3.0 V.
3. Input rise and fall times 2 ns–4 ns typical.

SWITCHING WAVEFORMS

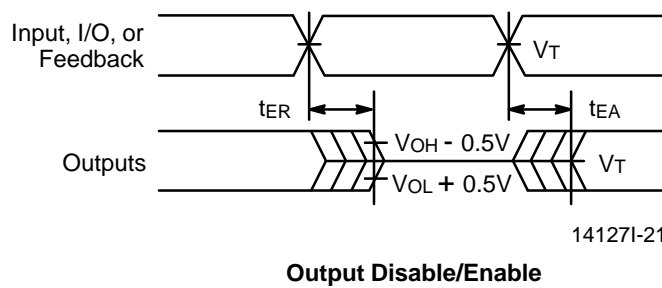
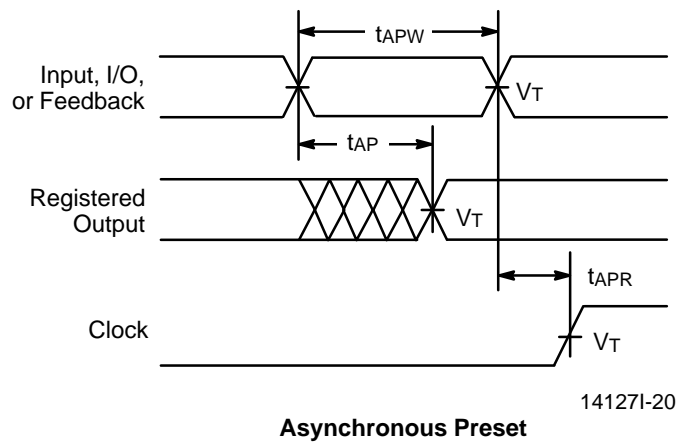
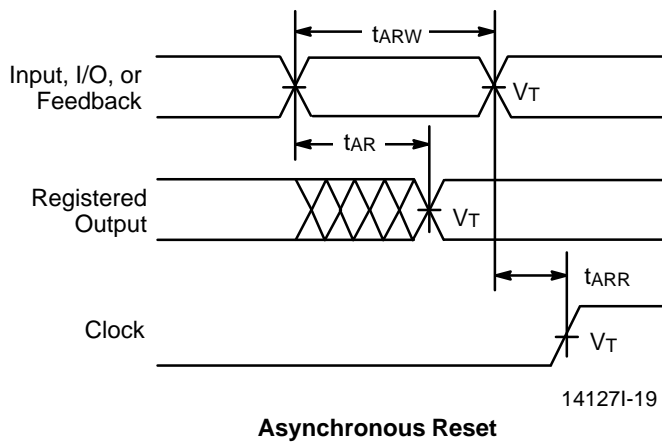
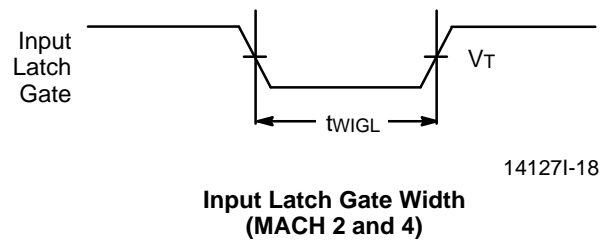
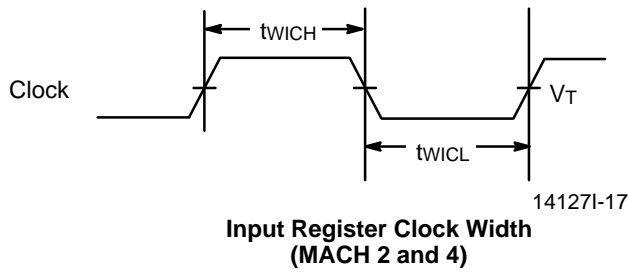

Notes:

1. $V_T = 1.5\text{ V}$.
2. Input pulse amplitude 0 V to 3.0 V.
3. Input rise and fall times 2 ns–4 ns typical.

KEY TO SWITCHING WAVEFORMS

WAVEFORM	INPUTS	OUTPUTS
	Must be Steady	Will be Steady
	May Change from H to L	Will be Changing from H to L
	May Change from L to H	Will be Changing from L to H
	Don't Care, Any Change Permitted	Changing, State Unknown
	Does Not Apply	Center Line is High-Impedance "Off" State

KS000010-PAL

SWITCHING TEST CIRCUIT

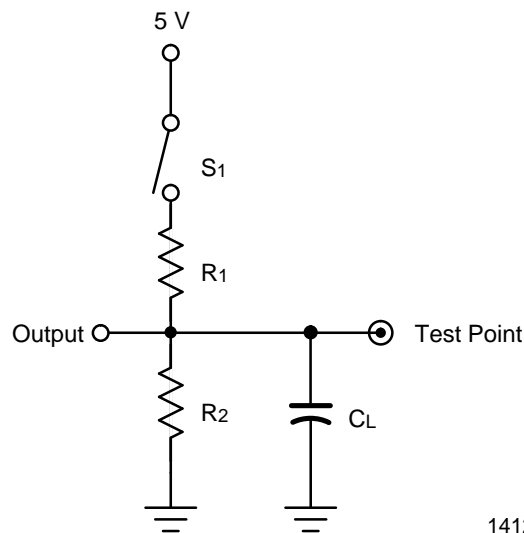

14127I-22

Specification	S ₁	C _L	Commercial		Measured Output Value
			R ₁	R ₂	
t _{PD} , t _{CO}	Closed	35 pF	300 Ω	390 Ω	1.5 V
t _{EA}	Z → H: Open Z → L: Closed				1.5 V
t _{ER}	H → Z: Open L → Z: Closed	5 pF			H → Z: V _{OH} - 0.5 V L → Z: V _{OL} + 0.5 V

*Switching several outputs simultaneously should be avoided for accurate measurement.

f_{MAX} PARAMETERS

The parameter f_{MAX} is the maximum clock rate at which the device is guaranteed to operate. Because the flexibility inherent in programmable logic devices offers a choice of clocked flip-flop designs, f_{MAX} is specified for three types of synchronous designs.

The first type of design is a state machine with feedback signals sent off-chip. This external feedback could go back to the device inputs, or to a second device in a multi-chip state machine. The slowest path defining the period is the sum of the clock-to-output time and the input setup time for the external signals (t_s + t_{CO}). The reciprocal, f_{MAX}, is the maximum frequency with external feedback or in conjunction with an equivalent speed device. This f_{MAX} is designated "f_{MAX} external."

The second type of design is a single-chip state machine with internal feedback only. In this case, flip-flop inputs are defined by the device inputs and flip-flop outputs. Under these conditions, the period is limited by the internal delay from the flip-flop outputs through the internal feedback and logic to the flip-flop inputs. This f_{MAX} is designated "f_{MAX} internal". A simple internal counter is a good example of this type of design; therefore, this parameter is sometimes called "f_{CNT}."

The third type of design is a simple data path application. In this case, input data is presented to the flip-flop and clocked through; no feedback is employed. Under these conditions, the period is limited by the sum of the data setup time and the data hold time (t_s + t_H). However, a lower limit for the period of each f_{MAX} type is the minimum clock period (t_{WH} + t_{WL}). Usually, this minimum clock period determines the period for the third f_{MAX}, designated "f_{MAX} no feedback."

For devices with input registers, one additional f_{MAX} parameter is specified: f_{MAXIR}. Because this involves no feedback, it is calculated the same way as f_{MAX} no feedback. The minimum period will be limited either by the sum of the setup and hold times (t_{SIR} + t_{HIR}) or the sum of the clock widths (t_{WICL} + t_{WICH}). The clock widths are normally the limiting parameters, so that f_{MAXIR} is specified as 1/(t_{WICL} + t_{WICH}). Note that if both input and output registers are used in the same path, the overall frequency will be limited by t_{ICS}.

All frequencies except f_{MAX} internal are calculated from other measured AC parameters. f_{MAX} internal is measured directly.

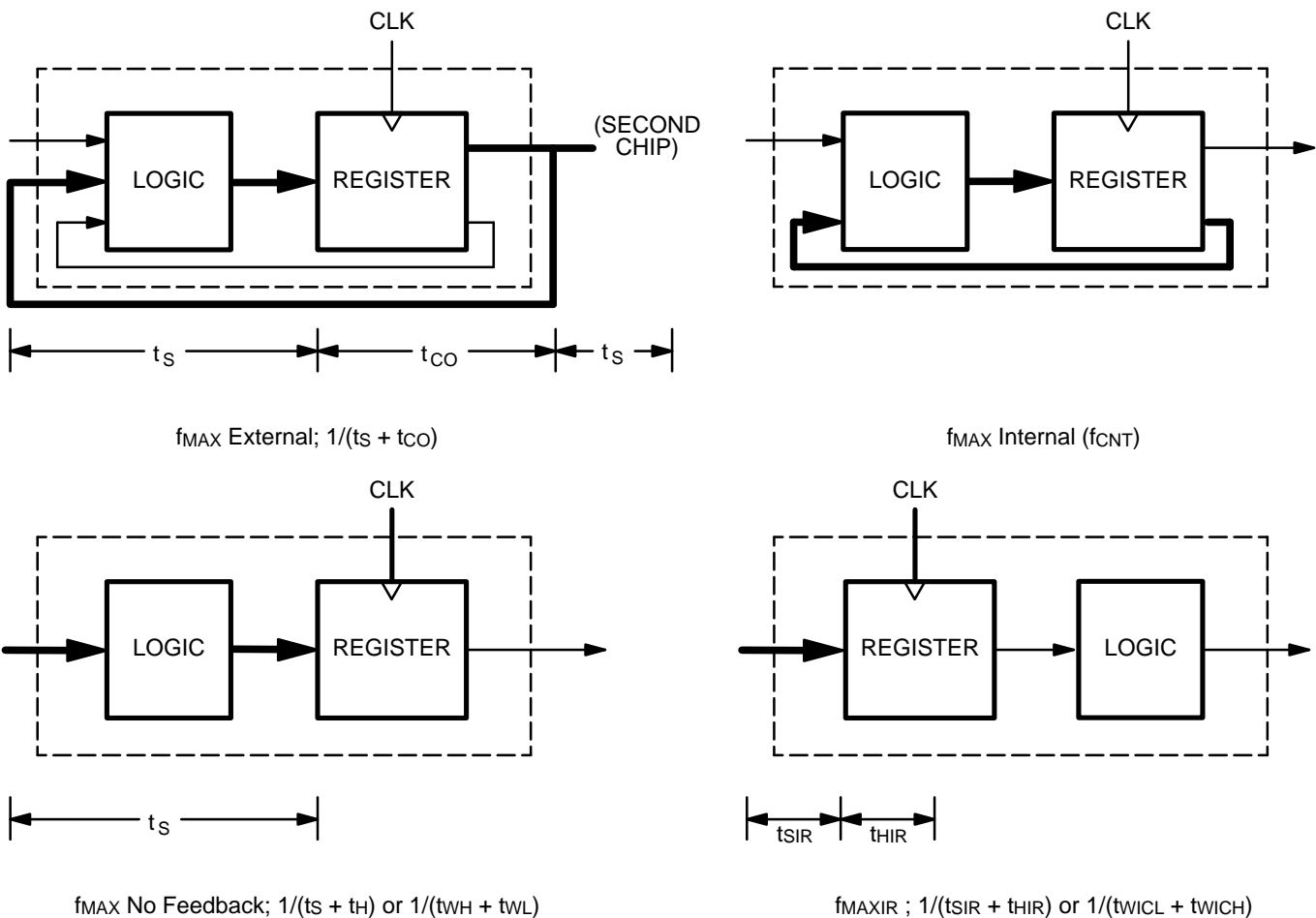

ENDURANCE CHARACTERISTICS

The MACH families are manufactured using AMD's advanced Electrically Erasable process. This technology uses an EE cell to replace the fuse link used in

bipolar parts. As a result, the device can be erased and reprogrammed, a feature which allows 100% testing at the factory.

Endurance Characteristics

Parameter Symbol	Parameter Description	Min	Units	Test Conditions
t _{DR}	Min Pattern Data Retention Time	10	Years	Max Storage Temperature
		20	Years	Max Operating Temperature
N	Max Reprogramming Cycles	100	Cycles	Normal Programming Conditions

INPUT/OUTPUT EQUIVALENT SCHEMATICS

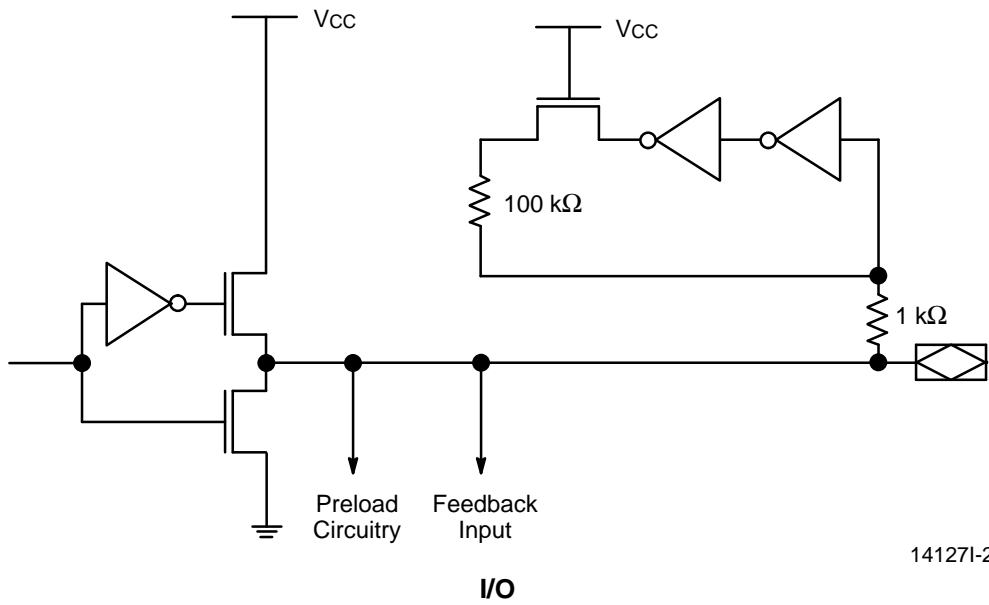
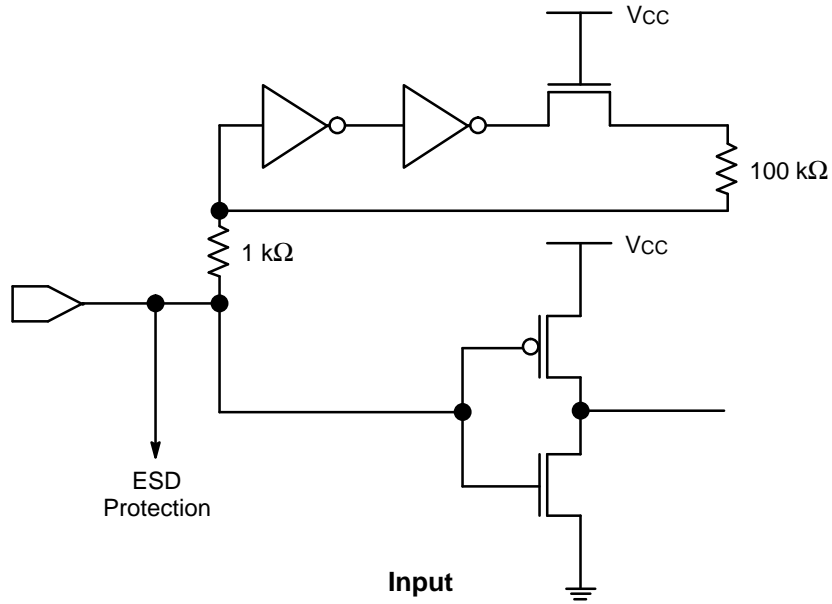

141271-24

POWER-UP RESET

The MACH devices have been designed with the capability to reset during system power-up. Following power-up, all flip-flops will be reset to LOW. The output state will depend on the logic polarity. This feature provides extra flexibility to the designer and is especially valuable in simplifying state machine initialization. A timing diagram and parameter table are shown below. Due to the synchronous operation of the power-up reset and the

wide range of ways V_{CC} can rise to its steady state, two conditions are required to insure a valid power-up reset. These conditions are:

1. The V_{CC} rise must be monotonic.
2. Following reset, the clock input must not be driven from LOW to HIGH until all applicable input and feedback setup times are met.

Parameter Symbol	Parameter Descriptions	Max	Unit
t_{PR}	Power-Up Reset Time	10	μs
t_s	Input or Feedback Setup Time	See Switching Characteristics	
t_{WL}	Clock Width LOW	See Switching Characteristics	

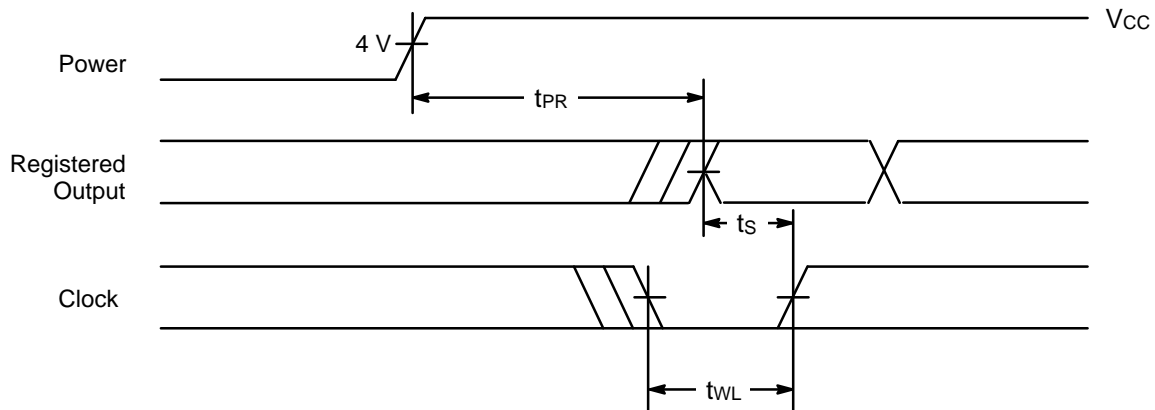

141271-25

Power-Up Reset Waveform

USING PRELOAD AND OBSERVABILITY

In order to be testable, a circuit must be both controllable and observable. To achieve this, the MACH devices incorporate register preload and observability.

In preload mode, each flip-flop in the MACH device can be loaded from the I/O pins, in order to perform functional testing of complex state machines. Register preload makes it possible to run a series of tests from a known starting state, or to load illegal states and test for proper recovery. This ability to control the MACH device's internal state can shorten test sequences, since it is easier to reach the state of interest.

The observability function makes it possible to see the internal state of the buried registers during test by overriding each register's output enable and activating the output buffer. The values stored in output and buried registers can then be observed on the I/O pins. Without this feature, a thorough functional test would be impossible for any designs with buried registers.

While the implementation of the testability features is fairly straightforward, care must be taken in certain instances to insure valid testing.

One case involves asynchronous reset and preset. If the MACH registers drive asynchronous reset or preset lines and are preloaded in such a way that reset or preset are asserted, the reset or preset may remove the preloaded data. This is illustrated in Figure 2. Care should be taken when planning functional tests, so that states that will cause unexpected resets and presets are not preloaded.

Another case to be aware of arises in testing combinatorial logic. When an output is configured as combinatorial, the observability feature forces the output into registered mode. When this happens, all product terms are forced to zero, which eliminates all combinatorial data. For a straight combinatorial output, the correct value will be restored after the preload or observe function, and there will be no problem. If the function implements a combinatorial latch, however, it relies on feedback to hold the correct value, as shown in Figure 3. As this value may change during the preload or observe operation, you cannot count on the data being correct after the operation. To insure valid testing in these cases, outputs that are combinatorial latches should not be tested immediately following a preload or observe sequence, but should first be restored to a known state.

All MACH 2 devices support both preload and observability.

Contact individual programming vendors in order to verify programmer support.

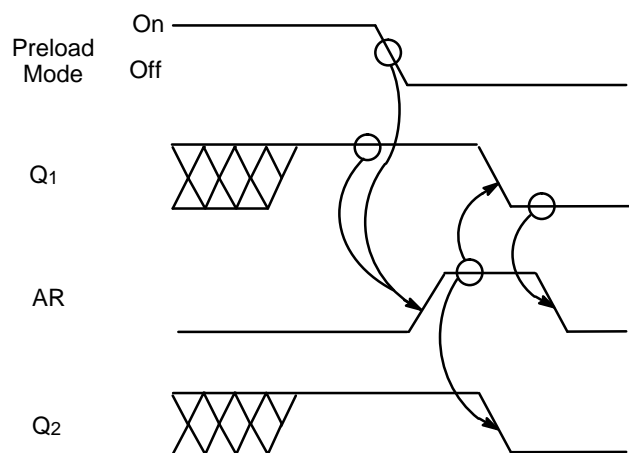
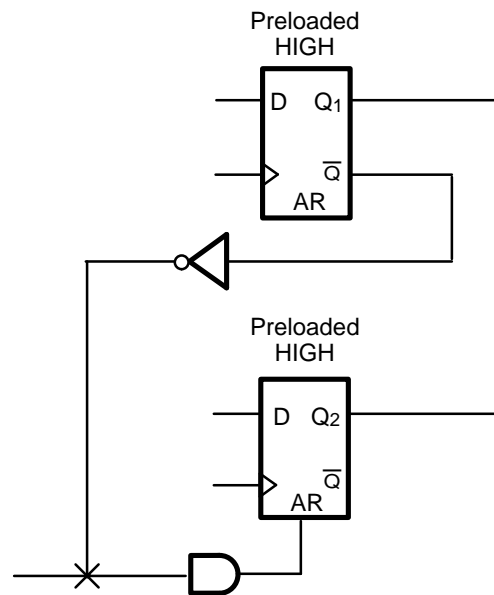

Figure 2. Preload/Reset Conflict

141271-26

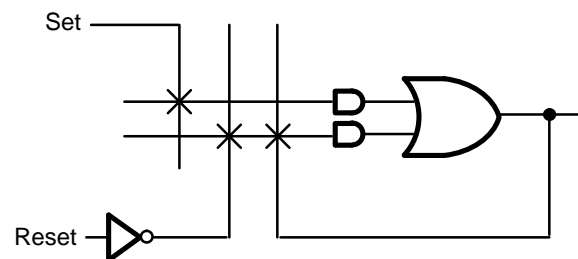

Figure 3. Combinatorial Latch

141271-27

DEVELOPMENT SYSTEMS (subject to change)

For more information on the products listed below, please consult the AMD FusionPLD Catalog.

MANUFACTURER	SOFTWARE DEVELOPMENT SYSTEMS
Advanced Micro Devices, Inc. P.O. Box 3453, MS 1028 Sunnyvale, CA 94088-3543 (800) 222-9323 or (408) 732-2400	MACHXL [®] Software Ver. 2.0
Advanced Micro Devices, Inc. P.O. Box 3453, MS 1028 Sunnyvale, CA 94088-3543 (800) 222-9323 or (408) 732-2400	Design Center/AMD Software
Advanced Micro Devices, Inc. P.O. Box 3453, MS 1028 Sunnyvale, CA 94088-3543 (800) 222-9323 or (408) 732-2400	AMD-ABEL Software Data I/O MACH Fitters
Advanced Micro Devices, Inc. P.O. Box 3453, MS 1028 Sunnyvale, CA 94088-3543 (800) 222-9323 or (408) 732-2400	PROdeveloper/AMD Software PROsynthesis/AMD Software
Cadence Design Systems 555 River Oaks Pkwy San Jose, CA 95134 (408) 943-1234	ComposerPIC [™] Designer (Requires MACH Fitter) Verilog, LeapFrog, RapidSim Simulators (Models also available from Logic Modeling) Ver. 3.3
Capilano Computing 960 Quayside Dr., Suite 406 New Westminster, B.C. Canada V3M 6G2 (800) 444-9064 or (604) 552-6200	MacABEL [™] Software (Requires SmartPart MACH Fitter)
CINA, Inc. P.O. Box 4872 Mountain View, CA 94040 (415) 940-1723	SmartCAT Circuit Analyzer
Data I/O Corporation 10525 Willows Road N.E. P.O. Box 97046 Redmond, WA 98073-9746 (800) 332-8246 or (206) 881-6444	ABEL [™] -5 Software (Requires MACH Fitter) Synario [™] Software
iNt GmbH Busenstrasse 6 D-8033 Martinsried, Munich, Germany (89) 857-6667	PLDSim 90
ISDATA GmbH Daimlerstr. 51 D7500 Karlsruhe 21 Germany Germany: 0721/75 10 87 U.S.: (510) 531-8553	LOG/iC [™] Software (Requires MACH Fitter)
Logic Modeling 19500 NW Gibbs Dr. P.O. Box 310 Beaverton, OR 97075 (503) 690-6900	SmartModel [®] Library
Logical Devices, Inc. 692 S. Military Trail Deerfield Beach, FL 33442 (800) 331-7766 or (305) 428-6868	CUPL [™] Software

DEVELOPMENT SYSTEMS (subject to change) (continued)

MANUFACTURER	SOFTWARE DEVELOPMENT SYSTEMS
Mentor Graphics Corp. 8005 S.W. Boeckman Rd. Wilsonville, OR 97070-7777 (800) 547-3000 or (503) 685-7000	PLDSynthesis™ (Requires MACH Fitter) QuickSim Simulator (Models also available from Logic Modeling)
MicroSim Corp. 20 Fairbanks Irvine, CA 92718 (714) 770-3022	Design Center Software (Requires MACH Fitter)
MINC Incorporated 6755 Earl Drive, Suite 200 Colorado Springs, CO 80918 (800) 755-FPGA or (719) 590-1155	PLDesigner™-XL Software (Requires MACH Fitter)
OrCAD 3175 N.W. Aloclek Dr. Hillsboro, OR 97124 (503) 690-9881	Programmable Logic Design Tools 386+ Schematic Design Tool 386+ Digital Simulation Tools
SUSIE-CAD 10000 Nevada Highway, Suite 201 Boulder City, NV 89005 (702) 293-2271	SUSIE™ Simulator
Teradyne EDA 321 Harrison Ave. Boston, MA 02118 (800) 777-2432 or (617) 422-2793	MultiSIM Interactive Simulator LASAR
Viewlogic Systems, Inc. 293 Boston Post Road West Marlboro, MA 01752 (800) 442-4660 or (508) 480-0881	ViewPLD or PROPLD (Requires PROSim Simulator MACH Fitter) ViewSim Simulator (Models for ViewSim also available from Logic Modeling)
MANUFACTURER	TEST GENERATION SYSTEM
Acugen Software, Inc. 427-3 Amherst St., Suite 391 Nashua, NH 03063 (603) 891-1995	ATGEN™ Test Generation Software
iNt GmbH Busenstrasse 6 D-8033 Martinsried, Munich, Germany (87) 857-6667	PLDCheck 90

Advanced Micro Devices is not responsible for any information relating to the products of third parties. The inclusion of such information is not a representation nor an endorsement by AMD of these products.

APPROVED PROGRAMMERS (subject to change)

For more information on the products listed below, please consult the AMD FusionPLD Catalog.

MANUFACTURER	PROGRAMMER CONFIGURATION
Advin Systems, Inc. 1050-L East Duane Ave. Sunnyvale, CA 94086 (408) 243-7000	Pilot U84
BP Microsystems 100 N. Post Oak Rd. Houston, TX 77055-7237 (800) 225-2102 or (713) 688-4600	BP1200
Data I/O Corporation 10525 Willows Road N.E. P.O. Box 97046 Redmond, WA 98073-9746 (800) 332-8246 or (206) 881-6444	UniSite™ Model 3900 AutoSite
Logical Devices Inc./Digelec 692 S. Military Trail Deerfield Beach, FL 33442 (800) 331-7766 or (305) 428-6868	ALLPRO™-88
SMS North America, Inc. 16522 NE 135th Place Redmond, WA 98052 (800) 722-4122 or SMS Im Grund 15 D-7988 Vangen Im Allgau, Germany 07522-5018	Sprint/Expert
Stag Microsystems Inc. 1600 Wyatt Dr. Suite 3 Santa Clara, CA 95054 (408) 988-1118 or Stag House Martinfield, Welwyn Garden City Herfordshire UK AL7 1JT 707-332148	Stag Quazar
System General 510 S. Park Victoria Dr. Milpitas, CA 95035 (408) 263-6667 or 3F, No. 1, Alley 8, Lane 45 Bao Shing Rd., Shin Diau Taipei, Taiwan 2-917-3005	Turpro-1

APPROVED ON-BOARD PROGRAMMERS

MANUFACTURER	PROGRAMMER CONFIGURATION
Corelis, Inc. 12607 Hidden Creek Way, Suite H Cerritos, California 70703 (310) 926-6727	JTAG PROG
Advanced Micro Devices P.O. Box 3453, MS-1028 Sunnyvale, CA 94088-3453 (800) 222-9323	MACHpro

PROGRAMMER SOCKET ADAPTERS (subject to change)

MANUFACTURER	PART NUMBER
EDI Corporation P.O. Box 366 Patterson, CA 95363 (209) 892-3270	Contact Manufacturer
Emulation Technology 2344 Walsh Ave., Bldg. F Santa Clara, CA 95051 (408) 982-0660	Contact Manufacturer
Logical Systems Corp. P.O. Box 6184 Syracuse, NY 13217-6184 (315) 478-0722	Contact Manufacturer
Procon Technologies, Inc. 1333 Lawrence Expwy, Suite 207 Santa Clara, CA 95051 (408) 246-4456	Contact Manufacturer

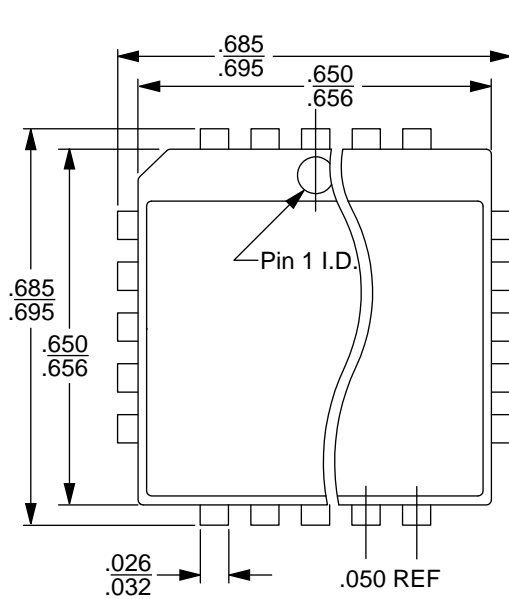
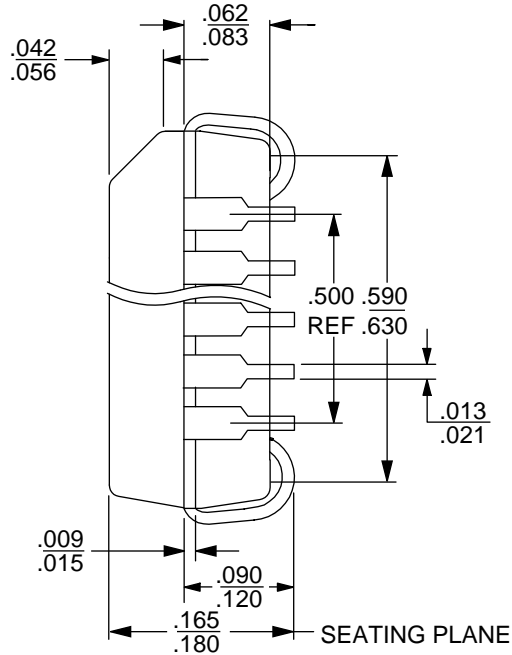
PHYSICAL DIMENSIONS*
PL 044
44-Pin Plastic Leaded Chip Carrier (measured in inches)

TOP VIEW

SIDE VIEW

 16-038-SQ
 PL 044
 DA78
 6-28-94 ae

*For reference only. BSC is an ANSI standard for Basic Space Centering.

Trademarks

Copyright © 1995 Advanced Micro Devices, Inc. All rights reserved.

AMD, the AMD logo, MACH, and PAL are registered trademarks of Advanced Micro Devices, Inc.

Product names used in this publication are for identification purposes only and may be trademarks of their respective companies.