

## +5V, Single Chip WAN Multi-Mode Serial Transceiver

- Interface Modes Supported:
  - ✓ RS-232 (v.28)      ✓ X.21/RS-422 (v.11)
  - ✓ EIA-530 (v.10 & v.11)    ✓ EIA-530A (v.10 & v.11)
  - ✓ RS-449 (v.10 & v.11)    ✓ V.35 (v.35 & v.28)
- Software Selectable Protocols
- Highest Differential Transmission Rates available at over 20Mbps
- +5V Only Operation
- Seven (7) Drivers and Seven (7) Receivers
- Driver and Receiver Tri-state Control
- Internal Transceiver Termination Resistors for V.11 and V.35 Protocols
- Improved ESD Tolerance for Analog I/Os
- Compliant to NET1/2 and TBR2 Physical Layer Requirements
- Used in WAN Serial Ports in Routers Switches, DSU/CSU's and other Access Devices
- Available in 132-Lead Small Scale Ball Grid Array and 80-Lead MQFP

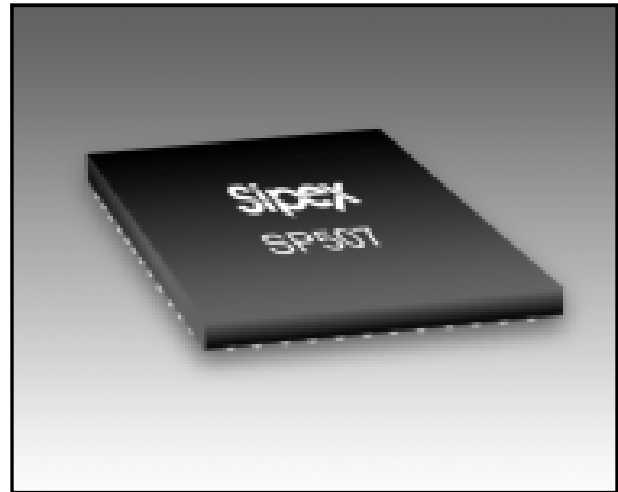

### DESCRIPTION

The **SP507** is a monolithic IC that supports seven (7) popular serial interface standards for DTE/DCE connectivity. The seven (7) drivers and seven (7) receivers transmit and receive signals at over 20Mbps. The **SP507** requires no additional external components for compliant operation for all seven (7) modes of operation. All necessary termination is integrated within the **SP507** and is switchable when V.35 drivers, V.35 receivers, and V.11 receivers are used. The **SP507** can operate as either a DTE or DCE.

Additional features include a latch enable pin with the driver and receiver address decoder. Tri-state ability for the driver and receiver outputs is controlled by supplying a 3-bit word into the address decoder. Four (4) drivers and four (4) receivers in the **SP507** include separate enable pins for added convenience.

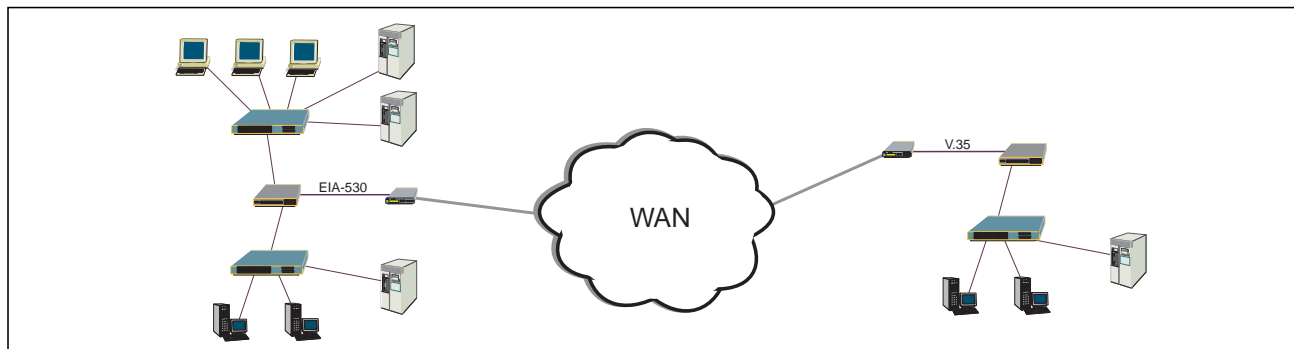

## ABSOLUTE MAXIMUM RATINGS

These are stress ratings only and functional operation of the device at these ratings or any other above those indicated in the operation sections of the specifications below is not implied. Exposure to absolute maximum rating conditions for extended periods of time may affect reliability.

$V_{CC}$ .....	+7V
Input Voltages:	
Logic.....	-0.3V to ( $V_{CC}+0.5V$ )
Drivers.....	-0.3V to ( $V_{CC}+0.5V$ )
Receivers.....	$\pm 15V$
Output Voltages:	
Logic.....	-0.3V to ( $V_{CC}+0.5V$ )
Drivers.....	$\pm 15V$
Receivers.....	-0.3V to ( $V_{CC}+0.5V$ )
Storage Temperature.....	-65°C to +150°C
Power Dissipation per package	
80-pin QFP (derate 18.3mW/°C above +70°C)...	1500mW

## STORAGE CONSIDERATIONS

Due to the relatively large package size of the 80-pin quad flat-pack, storage in a low humidity environment is preferred. Large high density plastic packages are moisture sensitive and should be stored in Dry Vapor Barrier Bags. Prior to usage, the parts should remain bagged and stored below 40°C and 60%RH. If the parts are removed from the bag, they should be used within 48 hours or stored in an environment at or below 20%RH. If the above conditions cannot be followed, the parts should be baked for four hours at 125°C in order to remove moisture prior to soldering. Sipex ships the 80-pin QFP in Dry Vapor Barrier Bags with a humidity indicator card and desiccant pack. The humidity indicator should be below 30%RH.

## SPECIFICATIONS

$T_A = +25^\circ\text{C}$  and  $V_{CC} = +4.75V$  to  $+5.25V$  unless otherwise noted.

	MIN.	TYP.	MAX.	UNITS	CONDITIONS
<b>LOGIC INPUTS</b>					
$V_{IL}$ $V_{IH}$	2.0		0.8	Volts Volts	
<b>LOGIC OUTPUTS</b>					
$V_{OL}$ $V_{OH}$	2.4		0.4	Volts Volts	$I_{OUT} = -3.2\text{mA}$ $I_{OUT} = 1.0\text{mA}$
<b>V.28 DRIVER</b>					
<b>DC Parameters</b>					
Outputs					
Open Circuit Voltage			$\pm 15$	Volts	per Figure 1
Loaded Voltage	$\pm 5.0$		$\pm 15$	Volts	per Figure 2
Short-Circuit Current			$\pm 100$	mA	per Figure 4
Power-Off Impedance	300			$\Omega$	per Figure 5
<b>AC Parameters</b>					
Outputs					
Transition Time			1.5	$\mu\text{s}$	per Figure 6; +3V to -3V
Instantaneous Slew Rate			30	V/ $\mu\text{s}$	per Figure 3
Propagation Delay					
$t_{PHL}$	0.5	1	5	$\mu\text{s}$	
$t_{PLH}$	0.5	1	5	$\mu\text{s}$	
Max. Transmission Rate	120	230		kbps	
<b>V.28 RECEIVER</b>					
<b>DC Parameters</b>					
Inputs					
Input Impedance	3		7	k $\Omega$	per Figure 7
Open-Circuit Bias			+2.0	Volts	per Figure 8
HIGH Threshold		1.7	3.0	Volts	
LOW Threshold	0.8	1.2		Volts	
<b>AC Parameters</b>					
Propagation Delay					
$t_{PHL}$	50	100	500	ns	$V_{CC} = +5V$ for AC parameters
$t_{PLH}$	50	100	500	ns	

# SPECIFICATIONS

T<sub>A</sub> = +25°C and V<sub>CC</sub> = +4.75V to +5.25V unless otherwise noted.

	MIN.	TYP.	MAX.	UNITS	CONDITIONS
<b>V.28 RECEIVER (continued)</b> <b>AC Parameters (cont.)</b> Max. Transmission Rate	120	230		kbps	
<b>V.10 DRIVER</b> <b>DC Parameters</b> Outputs Open Circuit Voltage Test-Terminated Voltage Short-Circuit Current Power-Off Current <b>AC Parameters</b> Outputs Transition Time Propagation Delay t <sub>PHL</sub> t <sub>PLH</sub> Max. Transmission Rate	±4.0 0.9V <sub>OC</sub>		±6.0 ±150 ±100	Volts Volts mA µA ns ns kbps	per Figure 9 per Figure 10 per Figure 11 per Figure 12 <b>V<sub>CC</sub> = +5V for AC parameters</b> per Figure 13; 10% to 90%
<b>V.10 RECEIVER</b> <b>DC Parameters</b> Inputs Input Current Input Impedance Sensitivity <b>AC Parameters</b> Propagation Delay t <sub>PHL</sub> t <sub>PLH</sub> Max. Transmission Rate	-3.25 4		+3.25 ±0.3	mA kΩ Volts ns ns kbps	per Figures 14 and 15 <b>V<sub>CC</sub> = +5V for AC parameters</b>
<b>V.11 DRIVER</b> <b>DC Parameters</b> Outputs Open Circuit Voltage Test Terminated Voltage Balance Offset Short-Circuit Current Power-Off Current <b>AC Parameters</b> Outputs Transition Time Propagation Delay t <sub>PHL</sub> t <sub>PLH</sub> Differential Skew Max. Transmission Rate	±2.0 0.5V <sub>OC</sub>		±5.0 0.67V <sub>OC</sub> ±0.4 +3.0 ±150 ±100	Volts Volts Volts Volts mA µA ns ns ns Mbps	per Figure 16 per Figure 17 per Figure 17 per Figure 17 per Figure 18 per Figure 19 <b>V<sub>CC</sub> = +5V for AC parameters</b> per Figures 21 and 36; 10% to 90% per Figures 33 and 36, C <sub>L</sub> = 50pF per Figures 33 and 36, C <sub>L</sub> = 50pF per Figures 33 and 36, C <sub>L</sub> = 50pF per Figure 33, C <sub>L</sub> = 50pF f <sub>IN</sub> = 10MHz
<b>V.11 RECEIVER</b> <b>DC Parameters</b> Inputs Common Mode Range Sensitivity	-7		+7 ±0.3	Volts Volts	

# SPECIFICATIONS

T<sub>A</sub> = +25°C and V<sub>CC</sub> = +4.75V to +5.25V unless otherwise noted.

	MIN.	TYP.	MAX.	UNITS	CONDITIONS
<b>V.11 RECEIVER (continued)</b>					
<b>DC Parameters (cont.)</b>					
Input Current	-3.25		±3.25	mA	per Figure 20 and 22
Current w/ 100Ω Termination			±60.75	mA	per Figure 23 and 24
Input Impedance	4			kΩ	
<b>AC Parameters</b>					
Propagation Delay					<b>V<sub>CC</sub> = +5V for AC parameters</b>
t <sub>PHL</sub>	30	65	85	ns	per Figures 33 and 38; C <sub>L</sub> = 50pF
t <sub>PLH</sub>	30	65	85	ns	per Figures 33 and 38; C <sub>L</sub> = 50pF
Differential Skew		10		ns	per Figure 33; C <sub>L</sub> = 50pF
Max. Transmission Rate	20			Mbps	per Figure 33; C <sub>L</sub> = 50pF f <sub>IN</sub> = 10MHz
<b>V.35 DRIVER</b>					
<b>DC Parameters</b>					
Outputs					
Open Circuit Voltage			±1.20	Volts	per Figure 16
Test Terminated Voltage	±0.44		±0.66	Volts	per Figure 25
Offset			±0.6	Volts	per Figure 25
Source Impedance	50		150	Ω	per Figure 27; Z <sub>S</sub> = V <sub>2</sub> /V <sub>1</sub> x 50Ω
Short-Circuit Impedance	135		165	Ω	per Figure 28
<b>AC Parameters</b>					
Outputs					
Transition Time		30	40	ns	per Figure 29; 10% to 90%
Propagation Delay					
t <sub>PHL</sub>	50	70	90	ns	per Figures 33 and 36; C <sub>L</sub> = 20pF
t <sub>PLH</sub>	50	70	90	ns	per Figures 33 and 36; C <sub>L</sub> = 20pF
Differential Skew		7	10	ns	per Figures 33 and 36; C <sub>L</sub> = 20pF
Max. Transmission Rate	20			Mbps	per Figure 33; C <sub>L</sub> = 20pF f <sub>IN</sub> = 10MHz
<b>V.35 RECEIVER</b>					
<b>DC Parameters</b>					
Inputs					
Sensitivity		±80		mV	
Source Impedance	90		110	Ω	per Figure 30; Z <sub>S</sub> = V <sub>2</sub> /V <sub>1</sub> x 50Ω
Short-Circuit Impedance	135		165	Ω	per Figure 31
<b>AC Parameters</b>					
Propagation Delay					<b>V<sub>CC</sub> = +5V for AC parameters</b>
t <sub>PHL</sub>	30	75	90	ns	per Figures 33 and 38; C <sub>L</sub> = 20pF
t <sub>PLH</sub>	30	75	90	ns	per Figures 33 and 38; C <sub>L</sub> = 20pF
Differential Skew		10		ns	per Figure 33; C <sub>L</sub> = 20pF
Max. Transmission Rate	20			Mbps	per Figure 33; C <sub>L</sub> = 20pF f <sub>IN</sub> = 10MHz
<b>TRANSCIEVER LEAKAGE CURRENTS</b>					
Driver Output 3-State Current		500		μA	
Rcvr Output 3-State Current		1	10	μA	per Figure 32; Drivers disabled Mx = 111, 0.4V ≤ V <sub>O</sub> ≤ 2.4V

## OTHER AC CHARACTERISTICS

$T_A = +25^\circ\text{C}$  and  $V_{CC} = +5.0\text{V}$  unless otherwise noted.

PARAMETER	MIN.	TYP.	MAX.	UNITS	CONDITIONS
<b>DRIVER DELAY TIME BETWEEN ACTIVE MODE AND TRI-STATE MODE</b>					
<b>RS-232/V.28</b>					
$t_{PZL}$ ; Tri-state to Output LOW		0.70	5.0	$\mu\text{s}$	$C_L = 100\text{pF}$ , Fig. 34 & 40; $S_1$ closed
$t_{PZH}$ ; Tri-state to Output HIGH		0.40	2.0	$\mu\text{s}$	$C_L = 100\text{pF}$ , Fig. 34 & 40; $S_2$ closed
$t_{PLZ}$ ; Output LOW to Tri-state		0.20	2.0	$\mu\text{s}$	$C_L = 100\text{pF}$ , Fig. 34 & 40; $S_1$ closed
$t_{PHZ}$ ; Output HIGH to Tri-state		0.40	2.0	$\mu\text{s}$	$C_L = 100\text{pF}$ , Fig. 34 & 40; $S_2$ closed
<b>RS-423/V.10</b>					
$t_{PZL}$ ; Tri-state to Output LOW		0.15	2.0	$\mu\text{s}$	$C_L = 100\text{pF}$ , Fig. 34 & 40; $S_1$ closed
$t_{PZH}$ ; Tri-state to Output HIGH		0.20	2.0	$\mu\text{s}$	$C_L = 100\text{pF}$ , Fig. 34 & 40; $S_2$ closed
$t_{PLZ}$ ; Output LOW to Tri-state		0.20	2.0	$\mu\text{s}$	$C_L = 100\text{pF}$ , Fig. 34 & 40; $S_1$ closed
$t_{PHZ}$ ; Output HIGH to Tri-state		0.15	2.0	$\mu\text{s}$	$C_L = 100\text{pF}$ , Fig. 34 & 40; $S_2$ closed
<b>RS-422/V.11</b>					
$t_{PZL}$ ; Tri-state to Output LOW		2.80	10.0	$\mu\text{s}$	$C_L = 100\text{pF}$ , Fig. 34 & 37; $S_1$ closed
$t_{PZH}$ ; Tri-state to Output HIGH		0.10	2.0	$\mu\text{s}$	$C_L = 100\text{pF}$ , Fig. 34 & 37; $S_2$ closed
$t_{PLZ}$ ; Output LOW to Tri-state		0.10	2.0	$\mu\text{s}$	$C_L = 15\text{pF}$ , Fig. 34 & 37; $S_1$ closed
$t_{PHZ}$ ; Output HIGH to Tri-state		0.10	2.0	$\mu\text{s}$	$C_L = 15\text{pF}$ , Fig. 34 & 37; $S_2$ closed
<b>V.35</b>					
$t_{PZL}$ ; Tri-state to Output LOW		2.60	10.0	$\mu\text{s}$	$C_L = 100\text{pF}$ , Fig. 34 & 37; $S_1$ closed
$t_{PZH}$ ; Tri-state to Output HIGH		0.10	2.0	$\mu\text{s}$	$C_L = 100\text{pF}$ , Fig. 34 & 37; $S_2$ closed
$t_{PLZ}$ ; Output LOW to Tri-state		0.10	2.0	$\mu\text{s}$	$C_L = 15\text{pF}$ , Fig. 34 & 37; $S_1$ closed
$t_{PHZ}$ ; Output HIGH to Tri-state		0.15	2.0	$\mu\text{s}$	$C_L = 15\text{pF}$ , Fig. 34 & 37; $S_2$ closed
<b>RECEIVER DELAY TIME BETWEEN ACTIVE MODE AND TRI-STATE MODE</b>					
<b>RS-232/V.28</b>					
$t_{PZL}$ ; Tri-state to Output LOW		0.12	2.0	$\mu\text{s}$	$C_L = 100\text{pF}$ , Fig. 35 & 38; $S_1$ closed
$t_{PZH}$ ; Tri-state to Output HIGH		0.10	2.0	$\mu\text{s}$	$C_L = 100\text{pF}$ , Fig. 35 & 38; $S_2$ closed
$t_{PLZ}$ ; Output LOW to Tri-state		0.10	2.0	$\mu\text{s}$	$C_L = 100\text{pF}$ , Fig. 35 & 38; $S_1$ closed
$t_{PHZ}$ ; Output HIGH to Tri-state		0.10	2.0	$\mu\text{s}$	$C_L = 100\text{pF}$ , Fig. 35 & 38; $S_2$ closed
<b>RS-423/V.10</b>					
$t_{PZL}$ ; Tri-state to Output LOW		0.10	2.0	$\mu\text{s}$	$C_L = 100\text{pF}$ , Fig. 35 & 38; $S_1$ closed
$t_{PZH}$ ; Tri-state to Output HIGH		0.10	2.0	$\mu\text{s}$	$C_L = 100\text{pF}$ , Fig. 35 & 38; $S_2$ closed
$t_{PLZ}$ ; Output LOW to Tri-state		0.10	2.0	$\mu\text{s}$	$C_L = 100\text{pF}$ , Fig. 35 & 38; $S_1$ closed
$t_{PHZ}$ ; Output HIGH to Tri-state		0.10	2.0	$\mu\text{s}$	$C_L = 100\text{pF}$ , Fig. 35 & 38; $S_2$ closed

## OTHER AC CHARACTERISTICS (Continued)

T<sub>A</sub> = +25°C and V<sub>CC</sub> = +5.0V unless otherwise noted.

PARAMETER	MIN.	TYP.	MAX.	UNITS	CONDITIONS
<b>RS-422/V.11</b>					
t <sub>PZL</sub> ; Tri-state to Output LOW		0.10	2.0	μs	C <sub>L</sub> = 100pF, Fig. 35 & 39; S <sub>1</sub> closed
t <sub>PZH</sub> ; Tri-state to Output HIGH		0.10	2.0	μs	C <sub>L</sub> = 100pF, Fig. 35 & 39; S <sub>2</sub> closed
t <sub>PLZ</sub> ; Output LOW to Tri-state		0.10	2.0	μs	C <sub>L</sub> = 15pF, Fig. 35 & 39; S <sub>1</sub> closed
t <sub>PHZ</sub> ; Output HIGH to Tri-state		0.10	2.0	μs	C <sub>L</sub> = 15pF, Fig. 35 & 39; S <sub>2</sub> closed
<b>V.35</b>					
t <sub>PZL</sub> ; Tri-state to Output LOW		0.10	2.0	μs	C <sub>L</sub> = 100pF, Fig. 35 & 39; S <sub>1</sub> closed
t <sub>PZH</sub> ; Tri-state to Output HIGH		0.10	2.0	μs	C <sub>L</sub> = 100pF, Fig. 35 & 39; S <sub>2</sub> closed
t <sub>PLZ</sub> ; Output LOW to Tri-state		0.10	2.0	μs	C <sub>L</sub> = 15pF, Fig. 35 & 39; S <sub>1</sub> closed
t <sub>PHZ</sub> ; Output HIGH to Tri-state		0.10	2.0	μs	C <sub>L</sub> = 15pF, Fig. 35 & 39; S <sub>2</sub> closed
<b>TRANSCEIVER TO TRANSCEIVER SKEW</b> (per Figures 33, 36, 38)					
V.28 Driver		100		ns	[ (t <sub>phl</sub> ) <sub>Tx1</sub> - (t <sub>phl</sub> ) <sub>Tx6,7</sub> ]
		100		ns	[ (t <sub>plh</sub> ) <sub>Tx1</sub> - (t <sub>plh</sub> ) <sub>Tx6,7</sub> ]
V.28 Receiver		20		ns	[ (t <sub>phl</sub> ) <sub>Rx1</sub> - (t <sub>phl</sub> ) <sub>Rx2,7</sub> ]
		20		ns	[ (t <sub>plh</sub> ) <sub>Rx1</sub> - (t <sub>plh</sub> ) <sub>Rx2,7</sub> ]
V.11 Driver		2		ns	[ (t <sub>phl</sub> ) <sub>Tx1</sub> - (t <sub>phl</sub> ) <sub>Tx6,7</sub> ]
		2		ns	[ (t <sub>plh</sub> ) <sub>Tx1</sub> - (t <sub>plh</sub> ) <sub>Tx6,7</sub> ]
V.11 Receiver		3		ns	[ (t <sub>phl</sub> ) <sub>Rx1</sub> - (t <sub>phl</sub> ) <sub>Rx2,7</sub> ]
		3		ns	[ (t <sub>plh</sub> ) <sub>Rx1</sub> - (t <sub>plh</sub> ) <sub>Rx2,7</sub> ]
V.10 Driver		5		ns	[ (t <sub>phl</sub> ) <sub>Tx2</sub> - (t <sub>phl</sub> ) <sub>Tx3,4,5</sub> ]
		5		ns	[ (t <sub>plh</sub> ) <sub>Tx2</sub> - (t <sub>plh</sub> ) <sub>Tx3,4,5</sub> ]
V.10 Receiver		5		ns	[ (t <sub>phl</sub> ) <sub>Rx2</sub> - (t <sub>phl</sub> ) <sub>Rx3,4,5</sub> ]
		5		ns	[ (t <sub>plh</sub> ) <sub>Rx2</sub> - (t <sub>plh</sub> ) <sub>Rx3,4,5</sub> ]
V.35 Driver		4		ns	[ (t <sub>phl</sub> ) <sub>Tx1</sub> - (t <sub>phl</sub> ) <sub>Tx6,7</sub> ]
		4		ns	[ (t <sub>plh</sub> ) <sub>Tx1</sub> - (t <sub>plh</sub> ) <sub>Tx6,7</sub> ]
V.35 Receiver		6		ns	[ (t <sub>phl</sub> ) <sub>Rx1</sub> - (t <sub>phl</sub> ) <sub>Rx2,7</sub> ]
		6		ns	[ (t <sub>plh</sub> ) <sub>Rx1</sub> - (t <sub>plh</sub> ) <sub>Rx2,7</sub> ]

## POWER REQUIREMENTS

PARAMETER	MIN.	TYP.	MAX.	UNITS	CONDITIONS
V <sub>CC</sub>	4.75	5.00	5.25	Volts	
I <sub>CC</sub> (No Mode Selected)		30		mA	All I <sub>CC</sub> values are with V <sub>CC</sub> = +5V f <sub>IN</sub> = 120kbps; Drivers active & loaded. f <sub>IN</sub> = 10Mbps; Drivers active & loaded. f <sub>IN</sub> = 10Mbps; Drivers active & loaded. V.35 @ f <sub>IN</sub> = 10Mbps, V.28 @ 120kbps; Drivers active & loaded.
(V.28/RS-232)		65		mA	
(V.11/X.21)		175		mA	
(EIA-530 & RS-449)		250		mA	
(V.35)		100		mA	

# TEST CIRCUITS

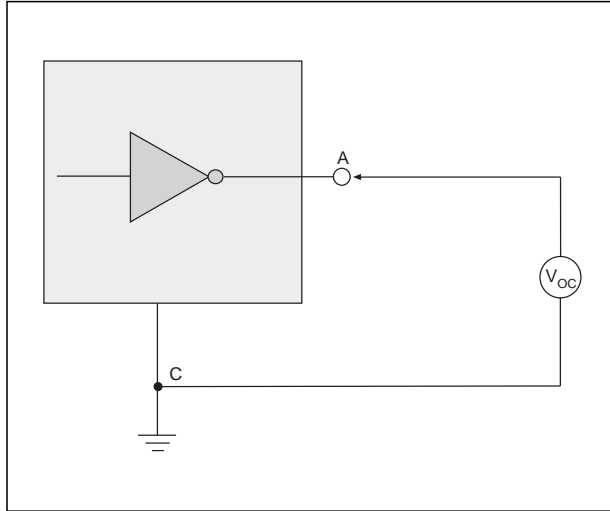

Figure 1. V.28 Driver Output Open Circuit Voltage

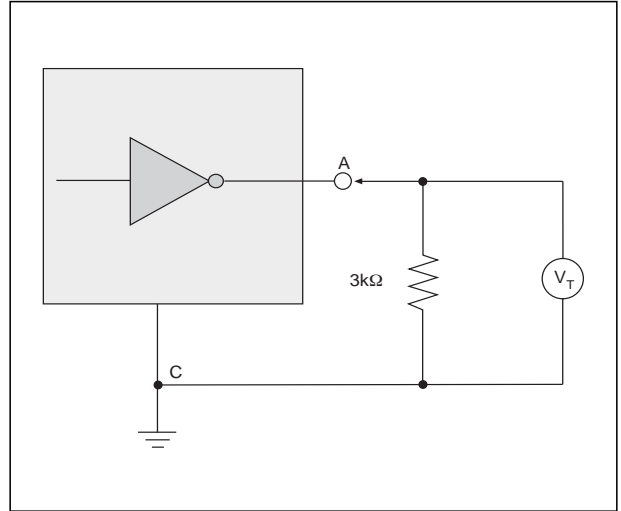

Figure 2. V.28 Driver Output Loaded Voltage

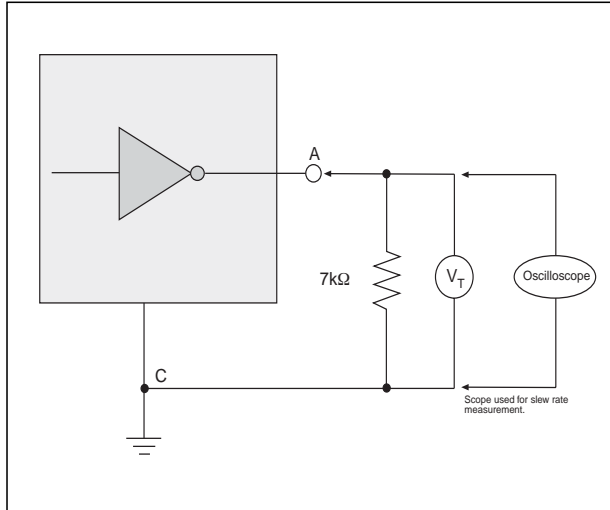

Figure 3. V.28 Driver Output Slew Rate

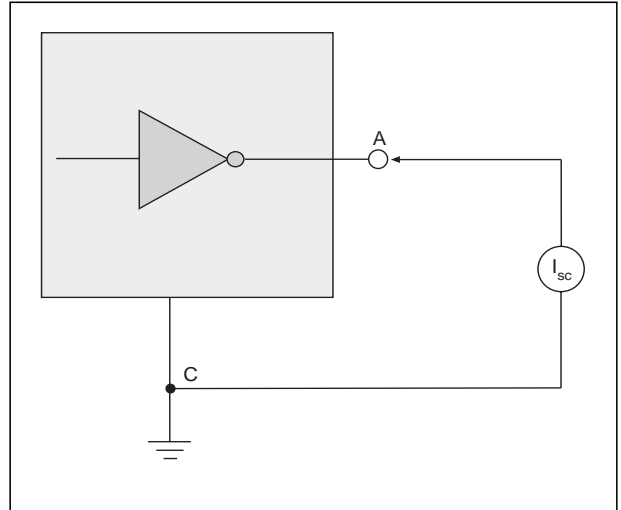

Figure 4. V.28 Driver Output Short-Circuit Current

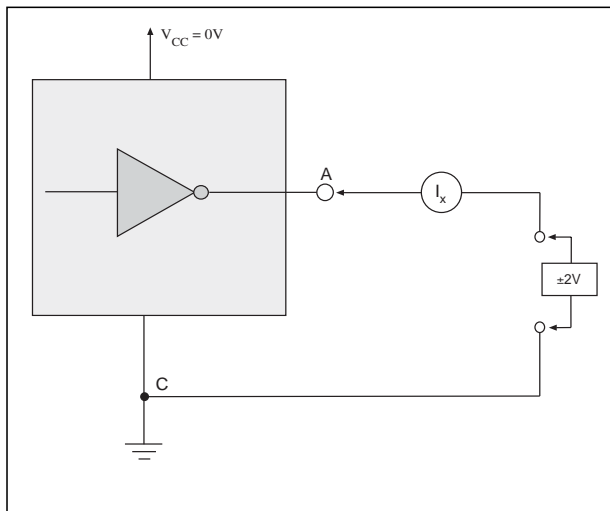

Figure 5. V.28 Driver Output Power-Off Impedance

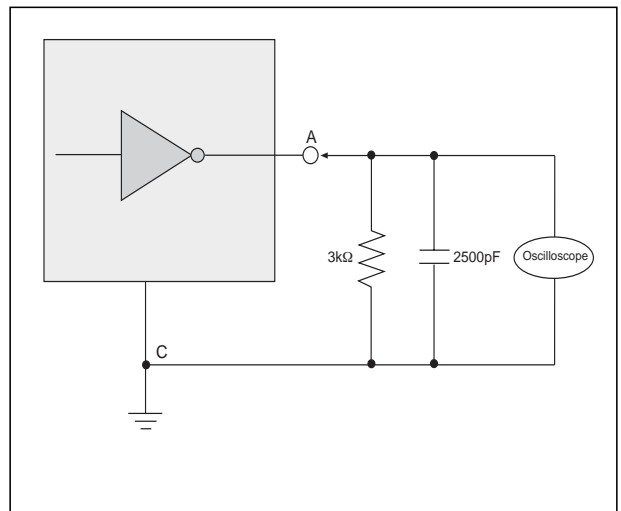

Figure 6. V.28 Driver Output Rise/Fall Times

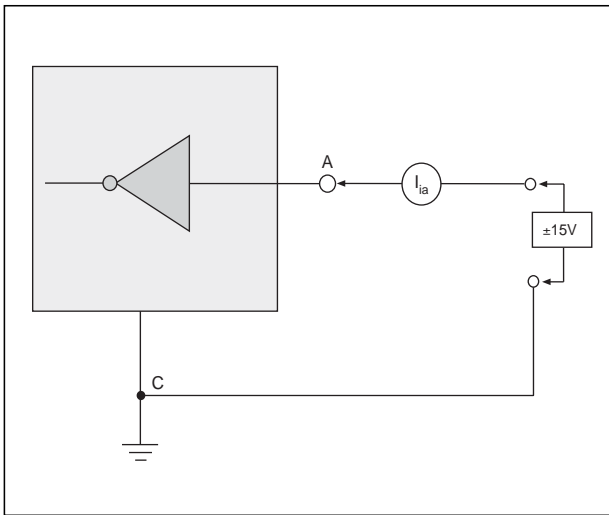

Figure 7. V.28 Receiver Input Impedance

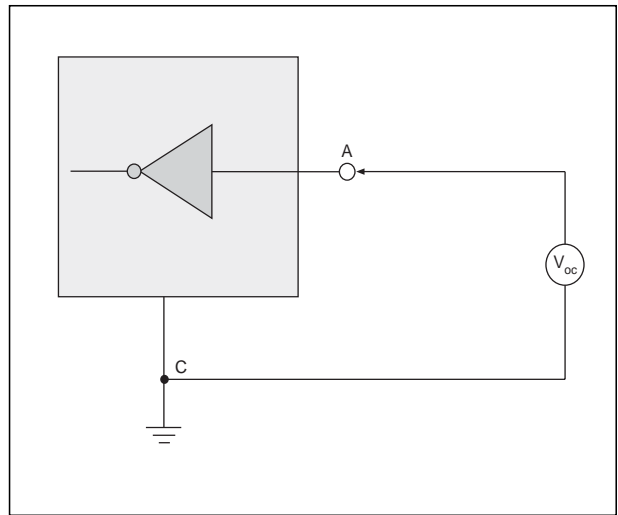

Figure 8. V.28 Receiver Input Open Circuit Bias

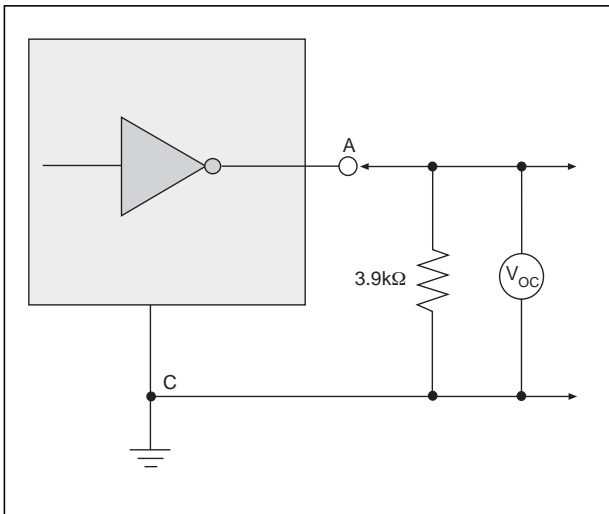

Figure 9. V.10 Driver Output Open-Circuit Voltage

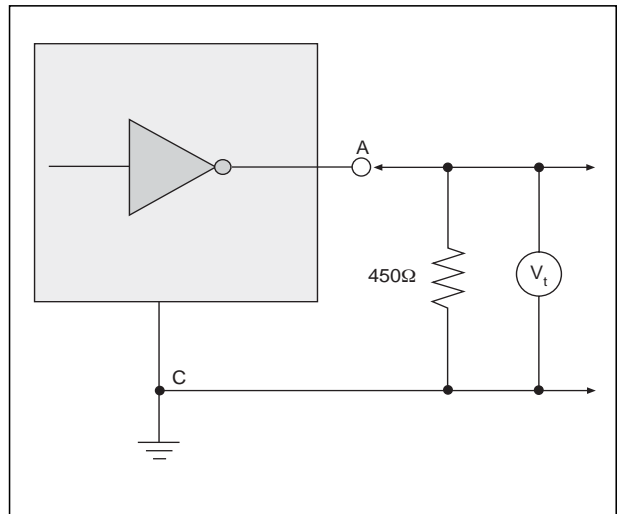

Figure 10. V.10 Driver Output Test Terminated Voltage

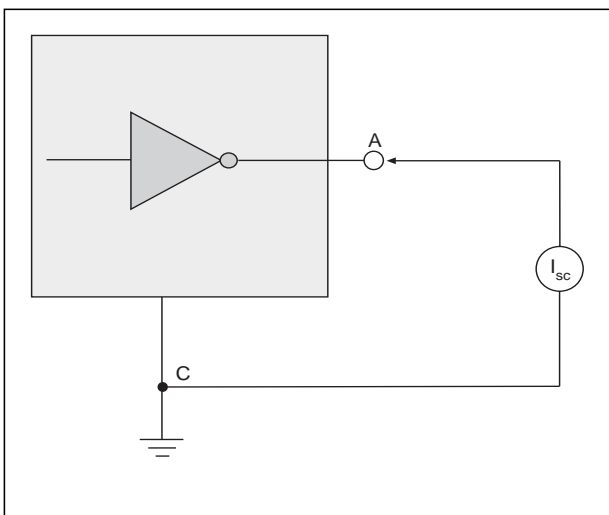

Figure 11. V.10 Driver Output Short-Circuit Current

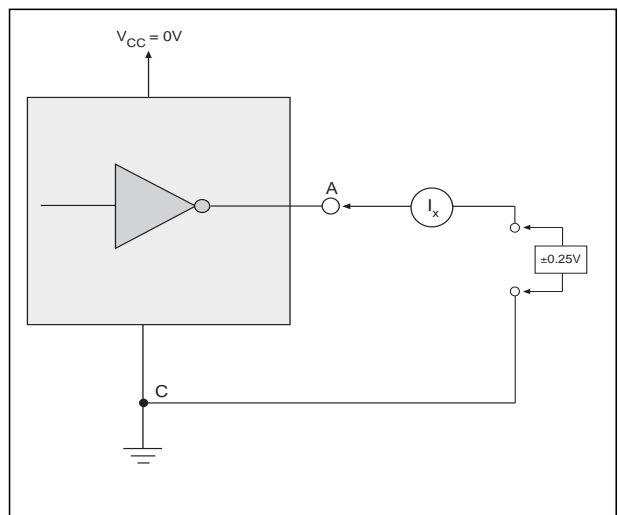

Figure 12. V.10 Driver Output Power-Off Current



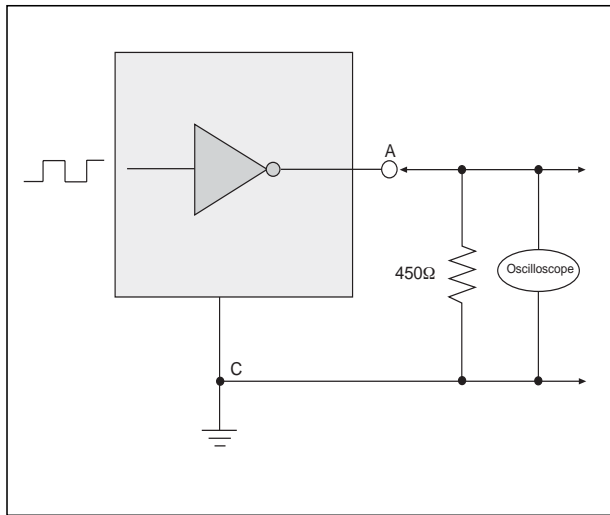

Figure 13. V.10 Driver Output Transition Time

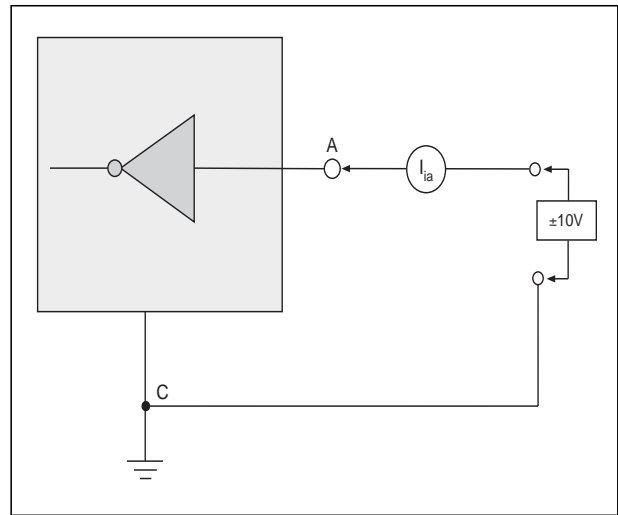

Figure 14. V.10 Receiver Input Current

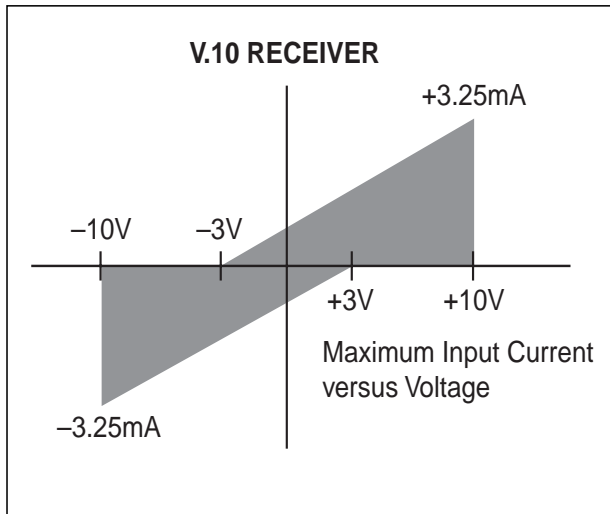

Figure 15. V.10 Receiver Input IV Graph

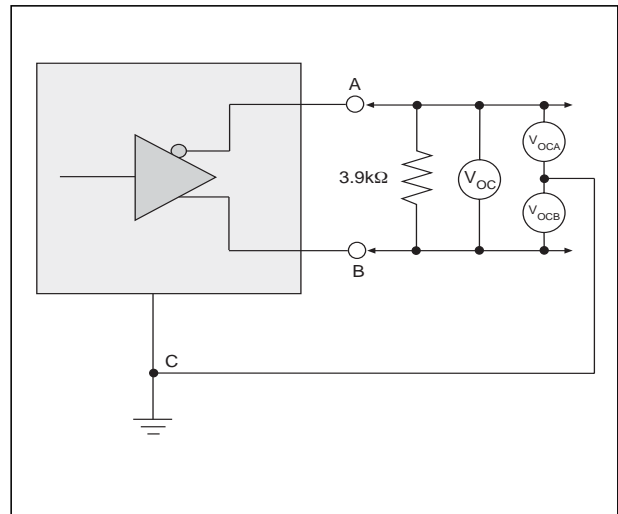

Figure 16. V.11 and V.35 Driver Output Open-Circuit Voltage

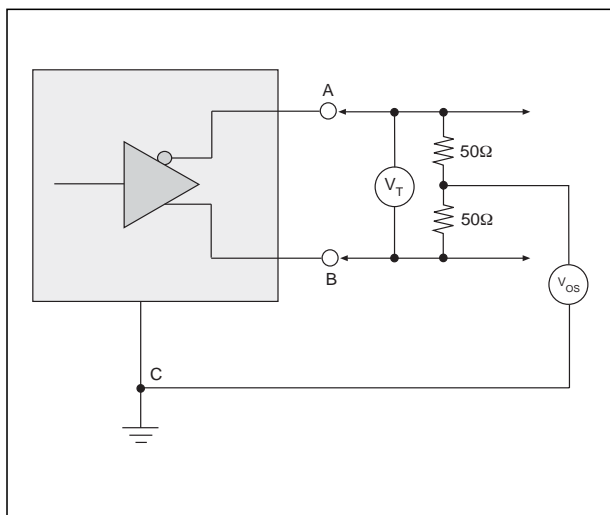

Figure 17. V.11 Driver Output Test Terminated Voltage

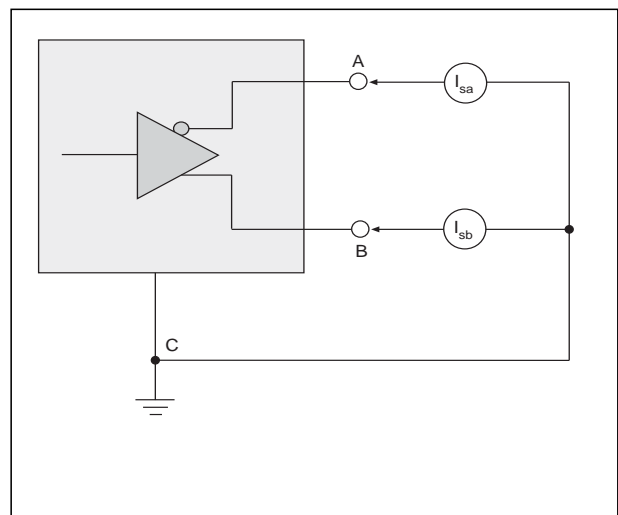

Figure 18. V.11 Driver Output Short-Circuit Current

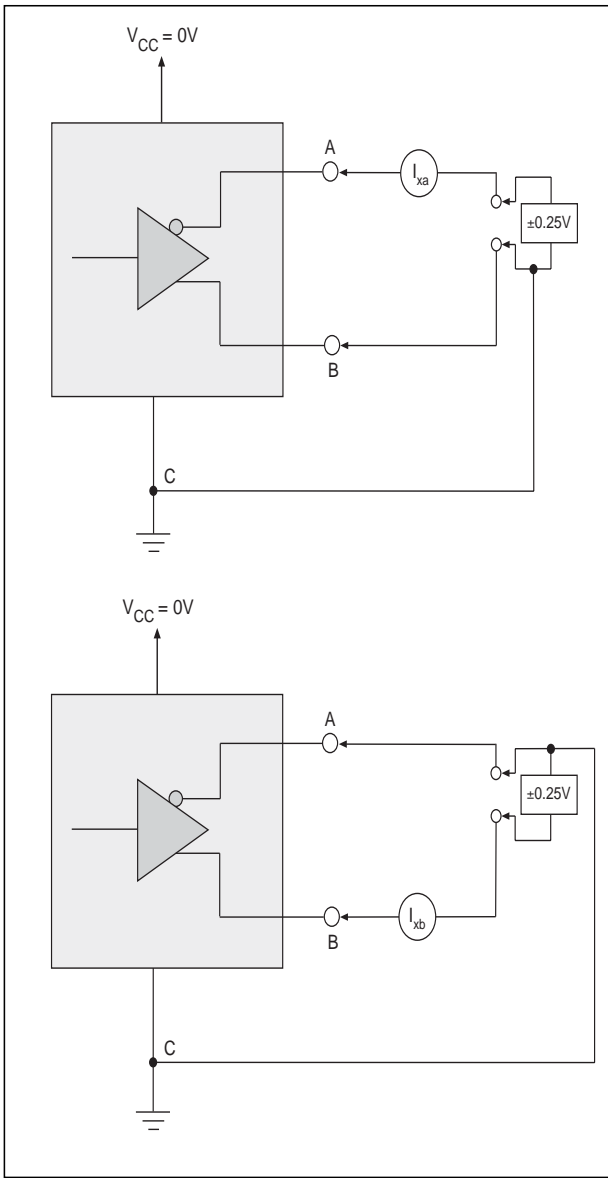

Figure 19. V.11 Driver Output Power-Off Current

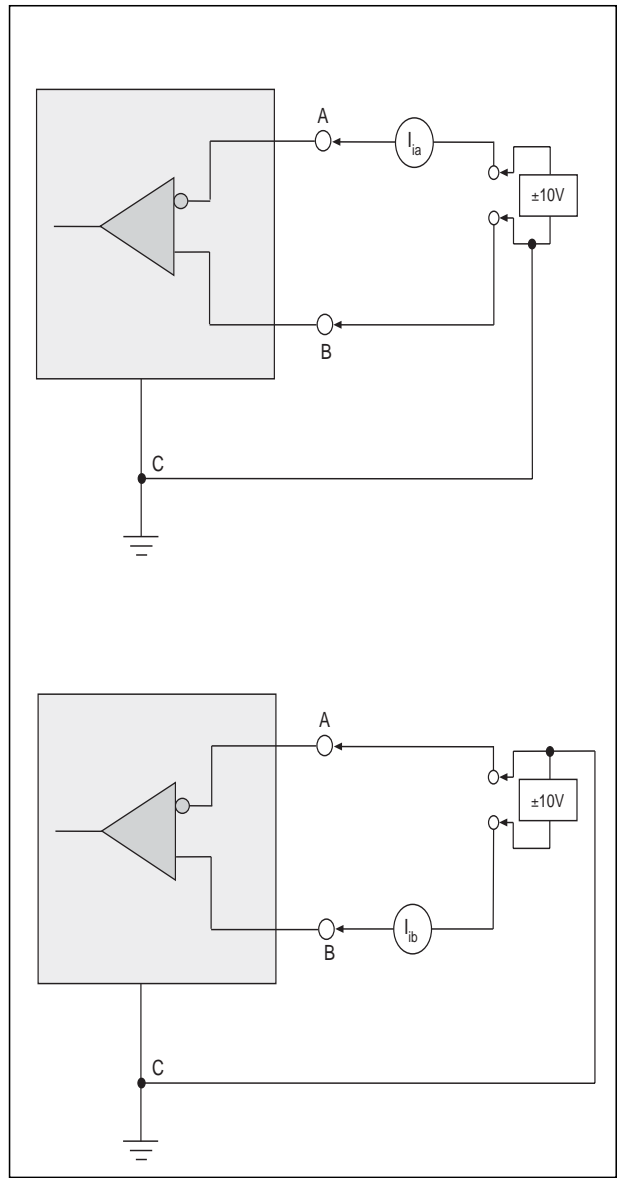

Figure 20. V.11 Receiver Input Current

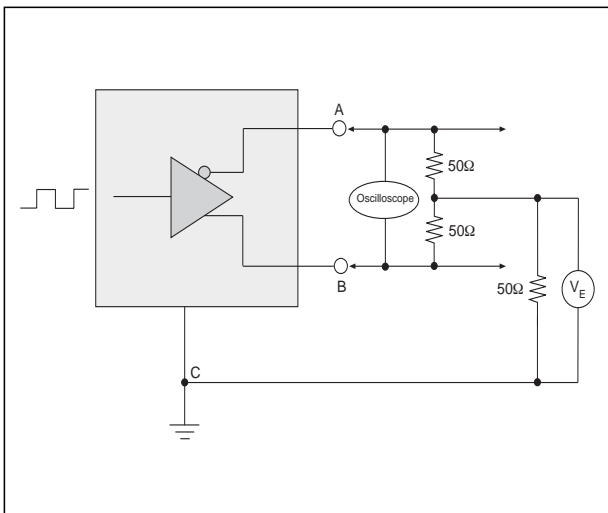

Figure 21. V.11 Driver Output Rise/Fall Time

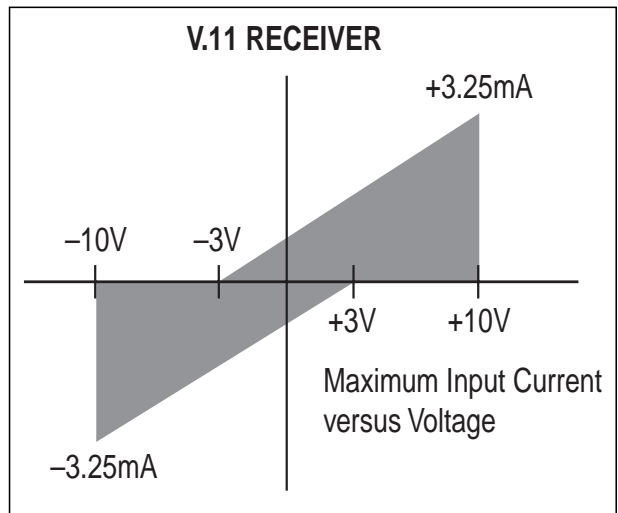

Figure 22. V.11 Receiver Input IV Graph

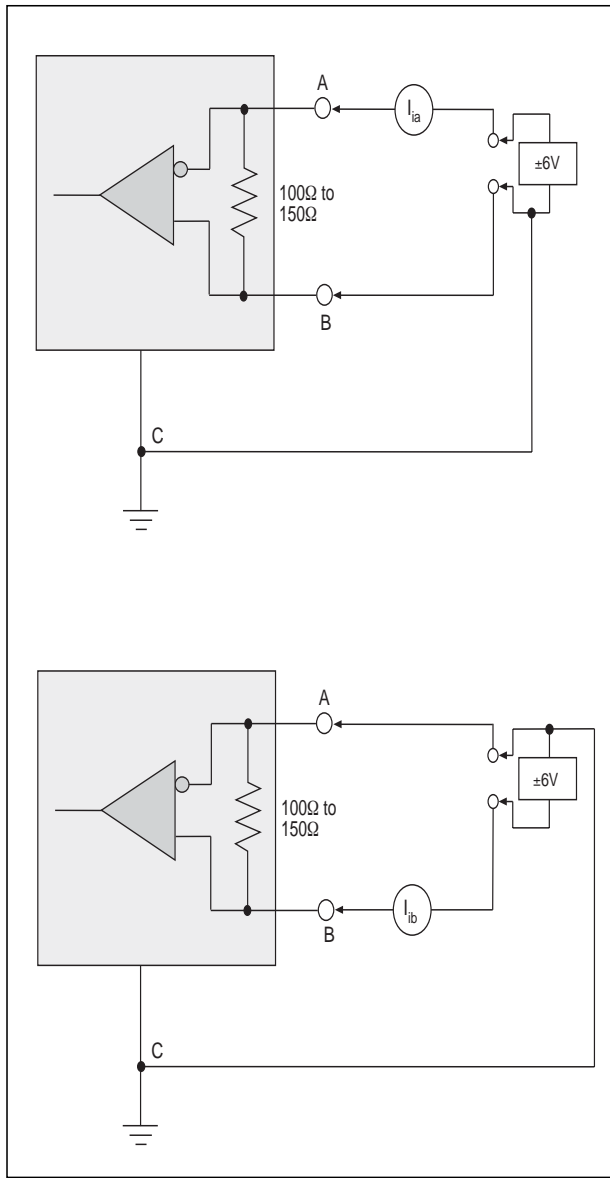

Figure 23. V.11 Receiver Input Current w/ Termination

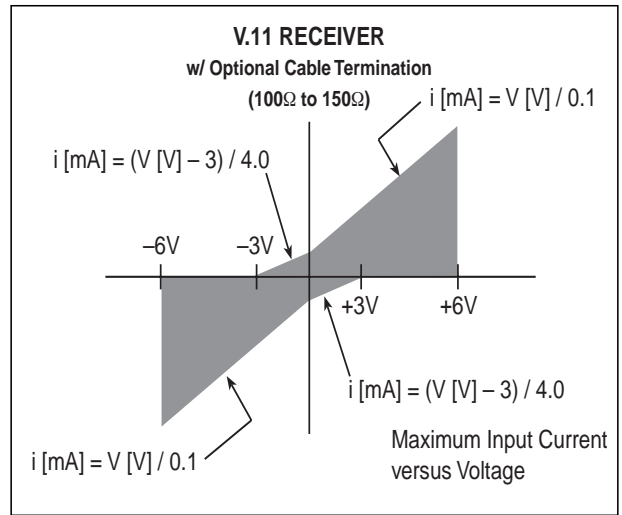

Figure 24. V.11 Receiver Input Graph w/ Termination

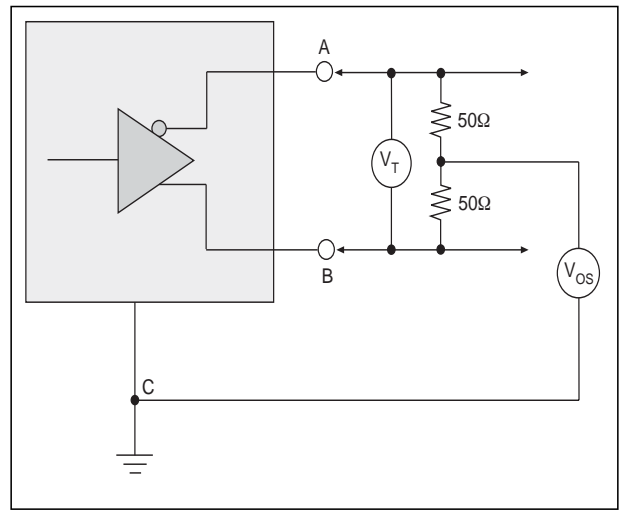

Figure 25. V.35 Driver Output Test Terminated Voltage

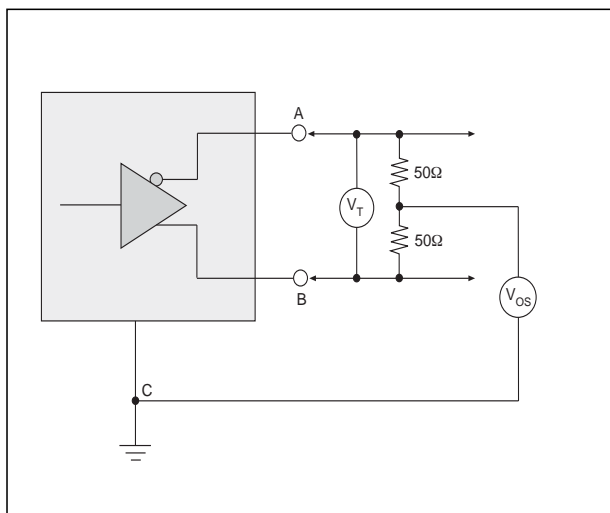

Figure 26. V.35 Driver Output Offset Voltage

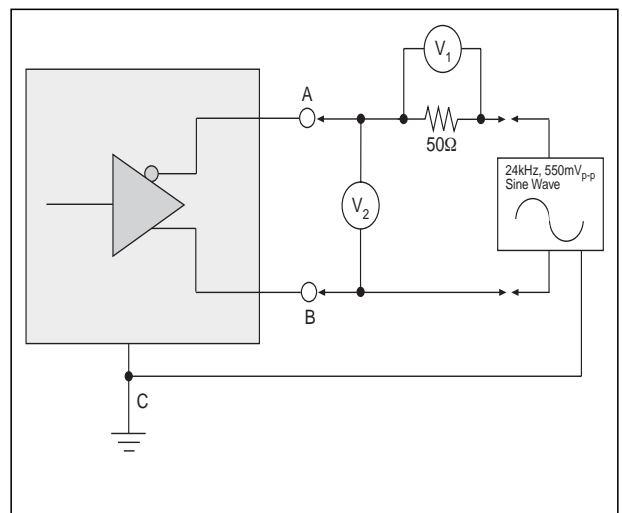

Figure 27. V.35 Driver Output Source Impedance

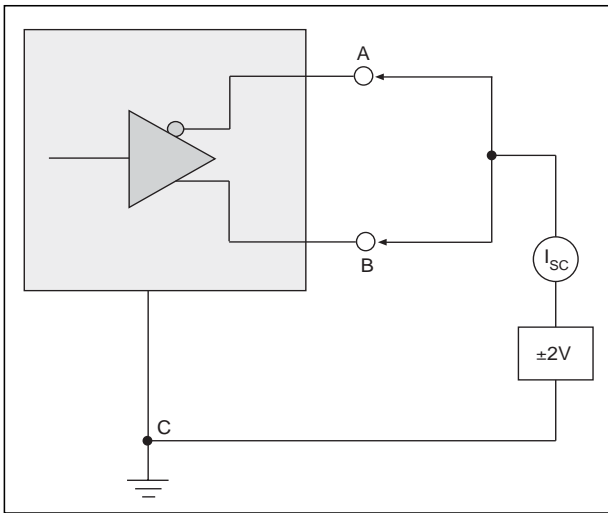

Figure 28. V.35 Driver Output Short-Circuit Impedance

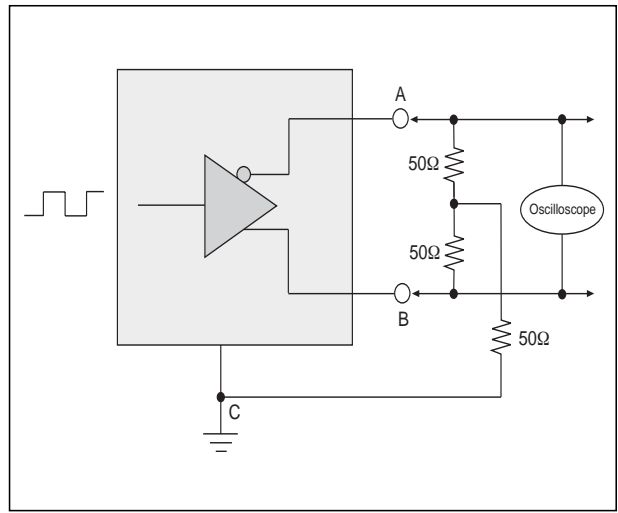

Figure 29. V.35 Driver Output Rise/Fall Time

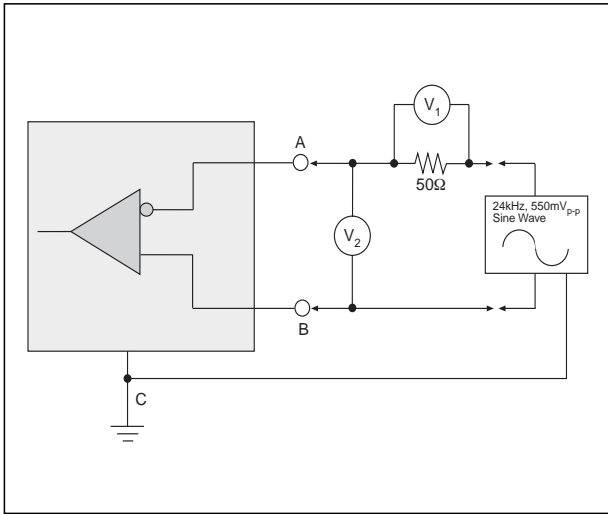

Figure 30. V.35 Receiver Input Source Impedance

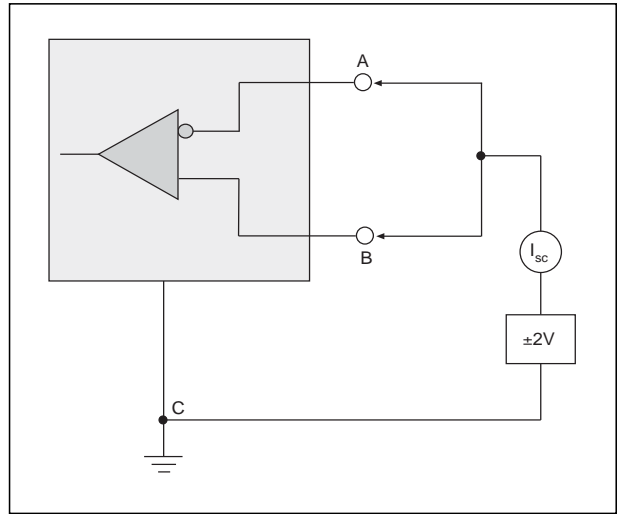

Figure 31. V.35 Receiver Input Short-Circuit Impedance

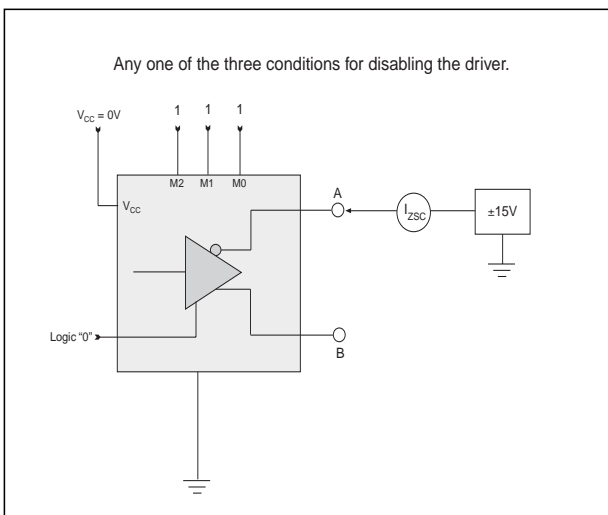

Figure 32. Driver Output Leakage Current Test

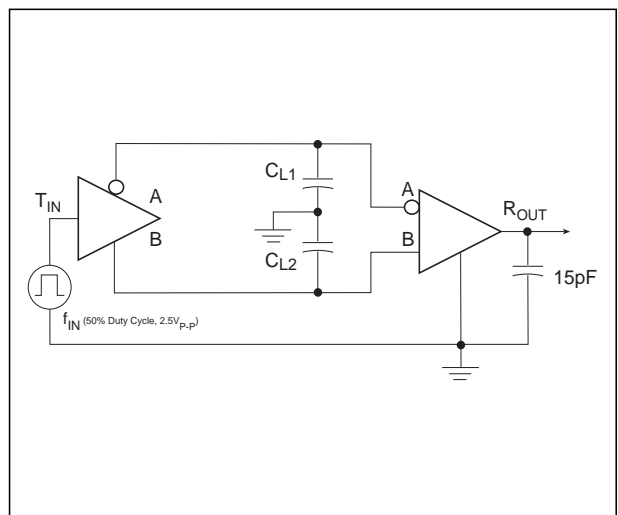

Figure 33. Driver/Receiver Timing Test Circuit

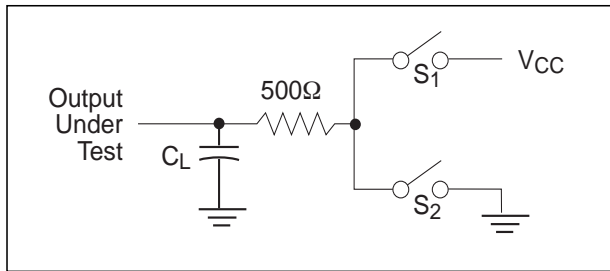

Figure 34. Driver Timing Test Load Circuit

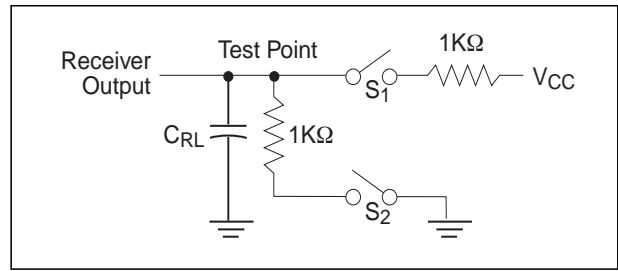

Figure 35. Receiver Timing Test Load Circuit

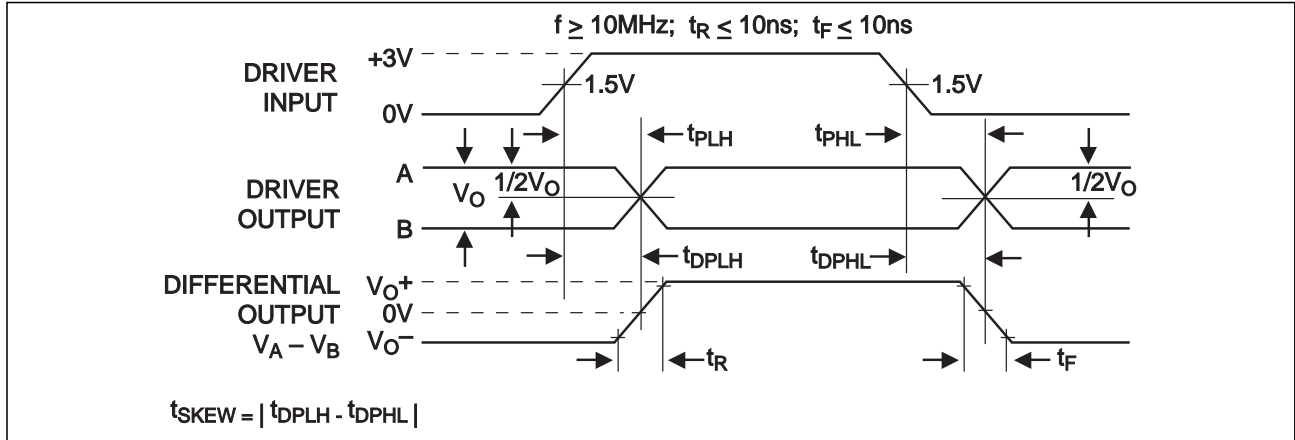

Figure 36. Driver Propagation Delays

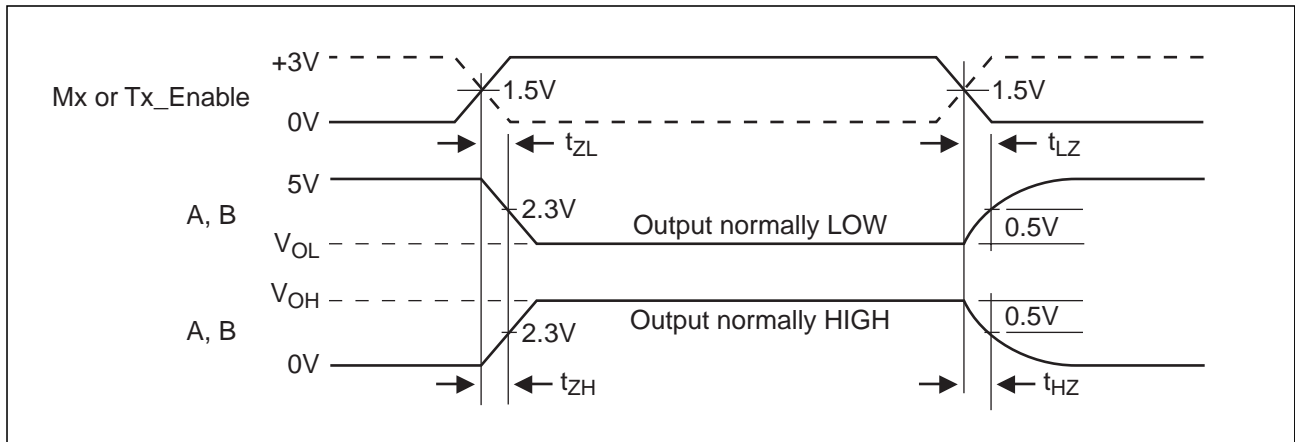

Figure 37. Driver Enable and Disable Times

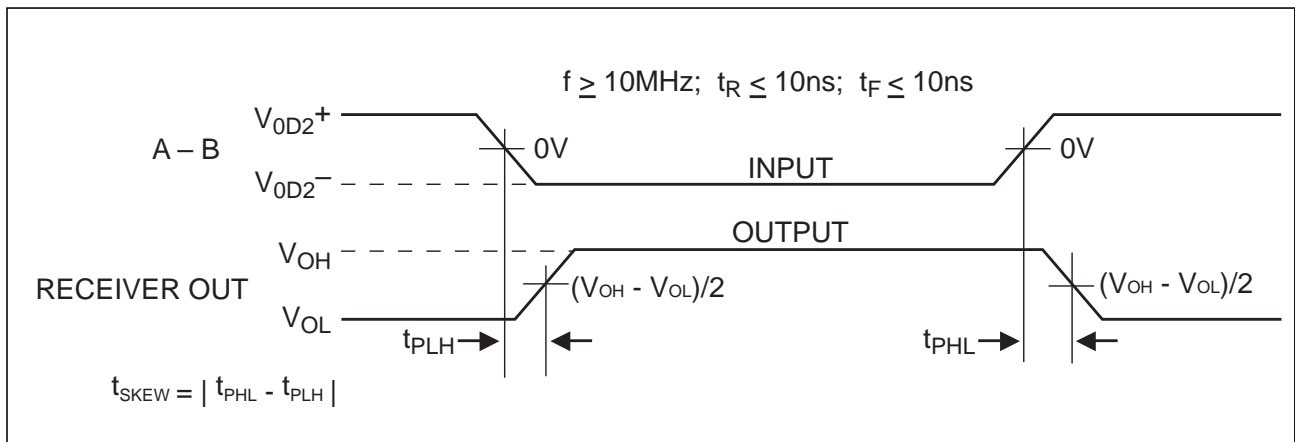

Figure 38. Receiver Propagation Delays

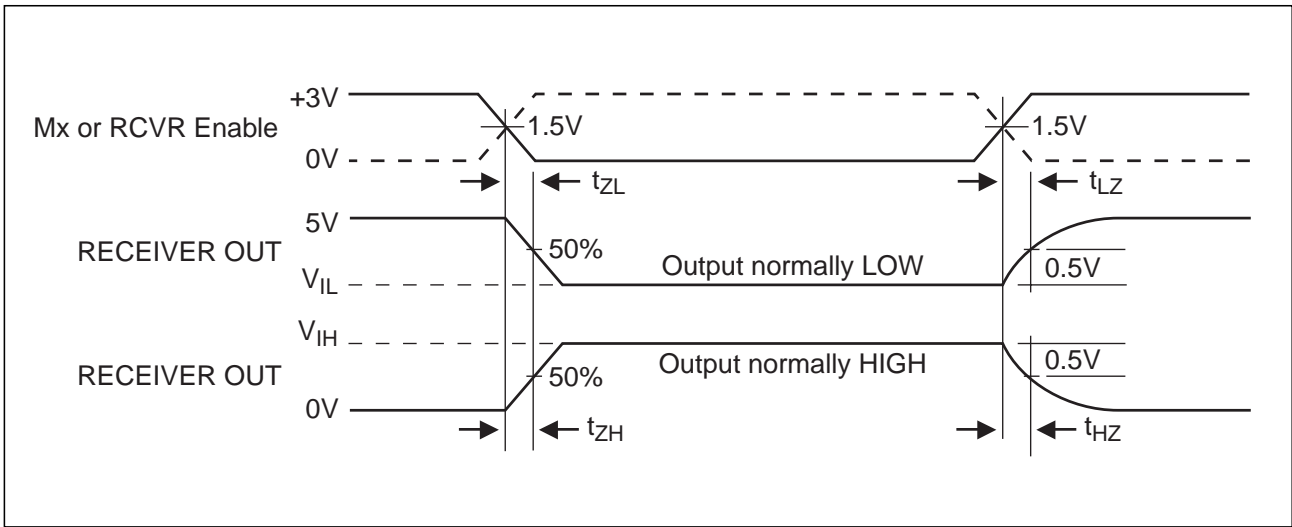

Figure 39. Receiver Enable and Disable Times

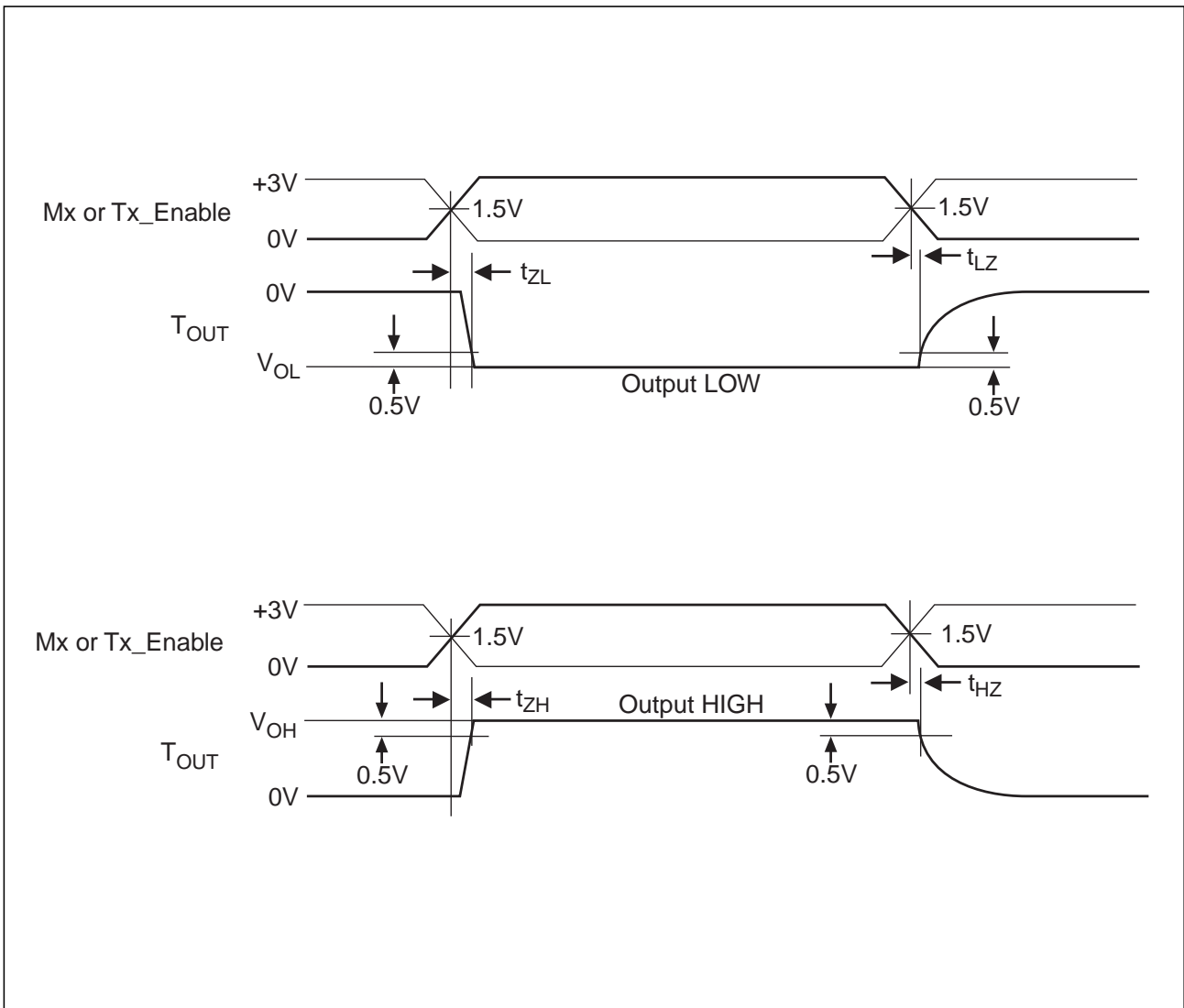

Figure 40. V.28 (RS-232) and V.10 (RS-423) Driver Enable and Disable Times

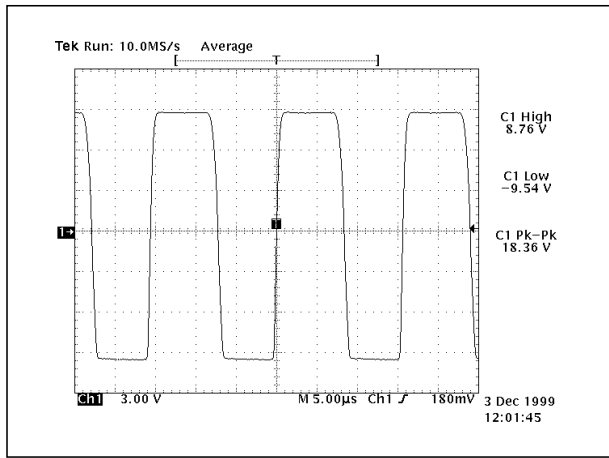

Figure 41. Typical V.28 Driver Output Waveform

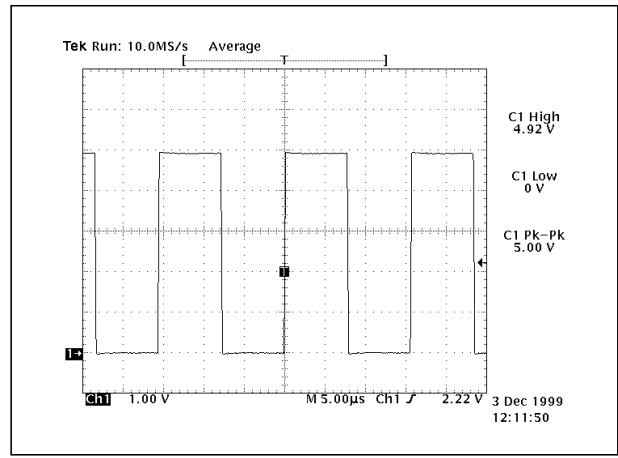

Figure 42. Typical V.10 Driver Output Waveform

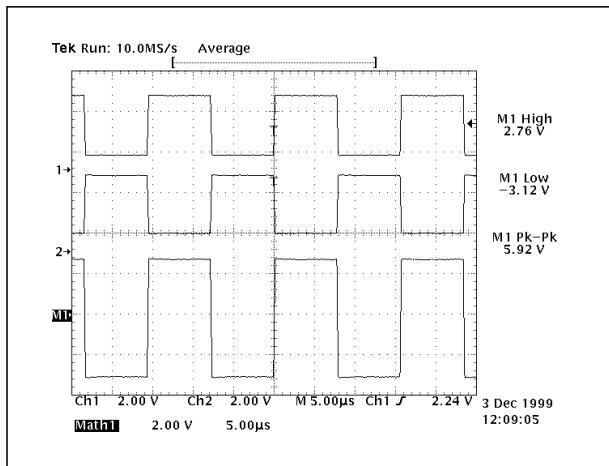

Figure 43. Typical V.11 Driver Output Waveforms

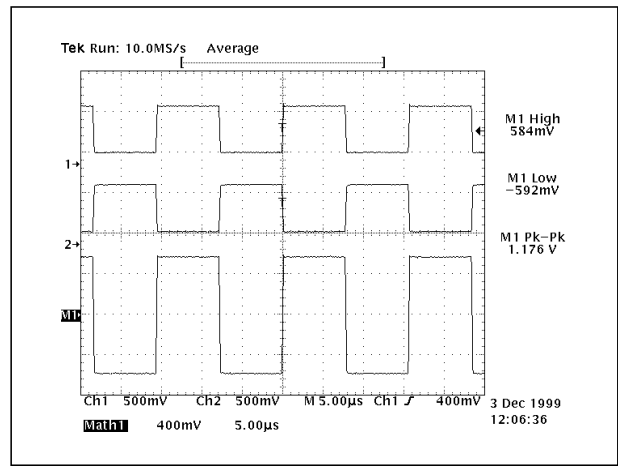
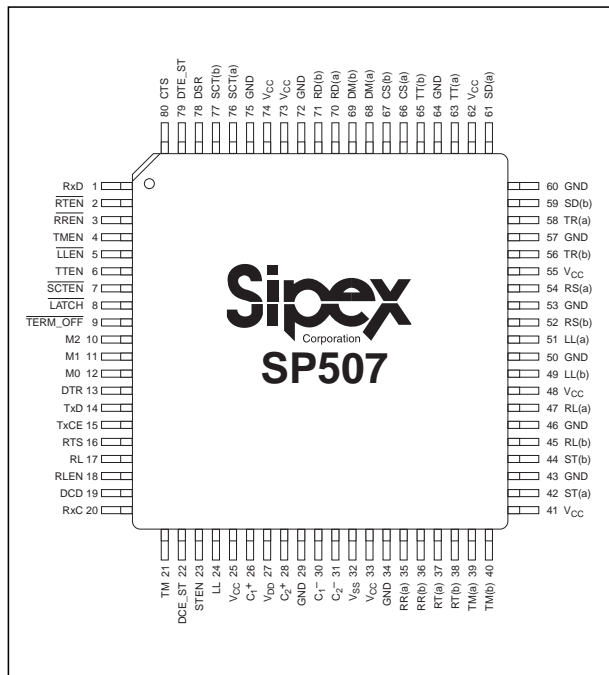

Figure 44. Typical V.35 Driver Output Waveforms

## PINOUT (QFP)



## PIN ASSIGNMENTS

### CLOCK AND DATA GROUP

Pin 1 — RxD — Receive Data; TTL output, sourced from RD(a) and RD(b) inputs.

Pin 14 — TxD — TTL input ; transmit data source for SD(a) and SD(b) outputs.

Pin 15 — TxCE — Transmit Clock; TTL input for TT driver outputs.

Pin 20 — RxC — Receive Clock; TTL output sourced from RT(a) and RT(b) inputs.

Pin 22 — DCE\_ST — Send Timing; TTL input; source for ST(a) and ST(b) outputs.

Pin 37 — RT(a) — Receive Timing; analog input, inverted; source for RxC.

Pin 38 — RT(b) — Receive Timing; analog input, non-inverted; source for RxC.

Pin 42 — ST(a) — Send Timing; analog output, inverted; sourced from DCE\_ST.

Pin 44 — ST(b) — Send Timing; analog output, non-inverted; sourced from DCE\_ST.

Pin 59 — SD(b) — Analog Out — Send data, non-inverted; sourced from TxD.

Pin 61 — SD(a) — Analog Out — Send data, inverted; sourced from TxD.

Pin 63 — TT(a) — Analog Out — Terminal Timing, inverted; sourced from TxCE.

Pin 65 — TT(b) — Analog Out — Terminal Timing, non-inverted; sourced from TxCE.

Pin 70 — RD(a) — Receive Data, analog input; inverted; source for RxD.

Pin 71 — RD(b) — Receive Data; analog input; non-inverted; source for RxD.

Pin 76 — SCT(a) — Serial Clock Transmit; analog input, inverted; source for DCE\_ST.

Pin 77 — SCT(b) — Serial Clock Transmit; analog input, non-inverted; source for DCE\_ST.

Pin 79 — DTE\_ST — Serial Clock Transmit; TTL output; sources from SCT(a) and SCT(b) inputs.

### CONTROL LINE GROUP

Pin 13 — DTR — Data Terminal Ready; TTL input; source for TR(a) and TR(b) outputs.

Pin 16 — RTS — Ready To Send; TTL input; source for RS(a) and RS(b) outputs.

Pin 17 — RL — Remote Loopback; TTL input; source for RL(a) and RL(b) outputs.

Pin 19 — DCD — Data Carrier Detect; TTL output; sourced from RR(a) and RR(b) inputs.

Pin 21 — TM — Ring In; TTL output; sourced from TM(a) and TM(b) inputs.

Pin 24 — LL — Local Loopback; TTL input; source for LL(a) and LL(b) outputs.

Pin 35 — RR(a) — Receiver Ready; analog input, inverted; source for DCD.

Pin 36 — RR(b) — Receiver Ready; analog input, non-inverted; source for DCD.

Pin 39 — TM(a) — Incoming Call; analog input, inverted; source for TM.

Pin 40 — TM(b) — Incoming Call; analog input, non-inverted; source for TM.



Pin 45 — RL(b) — Remote Loopback; analog output, non-inverted; sourced from RL.

Pin 47 — RL(a) — Remote Loopback; analog output inverted; sourced from RL.

Pin 49 — LL(b) — Local Loopback; analog output, non-inverted; sourced from LL.

Pin 51 — LL(a) — Local Loopback; analog output, inverted; sourced from LL.

Pin 52 — RS(b) — Ready To Send; analog output, non-inverted; sourced from RTS.

Pin 54 — RS(a) — Ready To Send; analog output, inverted; sourced from RTS.

Pin 56 — TR(b) — Terminal Ready; analog output, non-inverted; sourced from DTR.

Pin 58 — TR(a) — Terminal Ready; analog output, inverted; sourced from DTR.

Pin 66 — CS(a) — Clear To Send; analog input, inverted; source for CTS.

Pin 67 — CS(b) — Clear To Send; analog input, non-inverted; source for CTS.

Pin 68 — DM(a) — Data Mode; analog input, inverted; source for DSR.

Pin 69 — DM(b) — Data Mode; analog input, non-inverted; source for DSR.

Pin 78 — DSR — Data Set Ready; TTL output; sourced from DM(a) and DM(b) inputs.

Pin 80 — CTS — Clear To Send; TTL output; sourced from CS(a) and CS(b) inputs.

## CONTROL REGISTERS

Pin 2 —  $\overline{\text{RTEN}}$  — Enables RxC receiver, active low; TTL input.

Pin 3 —  $\overline{\text{RREN}}$  — Enables DCD receiver, active low; TTL input.

Pin 4 — TMEN — Enables TM receiver, active high; TTL input.

Pin 5 —  $\overline{\text{LLEN}}$  — Enables LL driver, active low; TTL input.

Pin 6 — TTEN — Enables TxCE driver, active high; TTL input.

Pin 7 —  $\overline{\text{SCTEN}}$  — Enables DTE\_ST receiver; active low; TTL input.

Pin 8 —  $\overline{\text{LATCH}}$  — Latch control for decoder bits (pins 10-12), active low. Logic high input will make decoder transparent.

Pin 9 —  $\overline{\text{TERM\_OFF}}$  — Disables receiver termination networks for RxD, RxC, and DTE\_ST; TTL input.

Pins 10,11, 12 — M2, M1, M0 — Transmitter and receiver decode register; configures transmitter and receiver modes; TTL inputs.

Pin 18 — RLEN — Enables RL driver; active high; TTL input.

Pin 23 — STEN — Enables DTE\_ST driver; active high; TTL input.

## POWER SUPPLIES

Pins 25, 33, 41, 48, 55, 62, 73, 74 —  $V_{CC}$  — +5V input.

Pins 29, 34, 43, 46, 50, 53, 57, 60, 64, 72, 75 — GND — Ground.

Pin 27 —  $V_{DD} +10\text{V}$  Charge Pump Capacitor — Connects from  $V_{DD}$  to  $V_{CC}$ . Suggested capacitor size is 22 $\mu\text{F}$ , 16V.

Pin 32 —  $V_{SS} -10\text{V}$  Charge Pump Capacitor — Connects from ground to  $V_{SS}$ . Suggested capacitor size is 22 $\mu\text{F}$ , 16V.

Pins 26 and 30 —  $C_1^+$  and  $C_1^-$  — Charge Pump Capacitor — Connects from  $C_1^+$  to  $C_1^-$ . Suggested capacitor size is 22 $\mu\text{F}$ , 16V.

Pins 28 and 31 —  $C_2^+$  and  $C_2^-$  — Charge Pump Capacitor — Connects from  $C_2^+$  to  $C_2^-$ . Suggested capacitor size is 22 $\mu\text{F}$ , 16V.

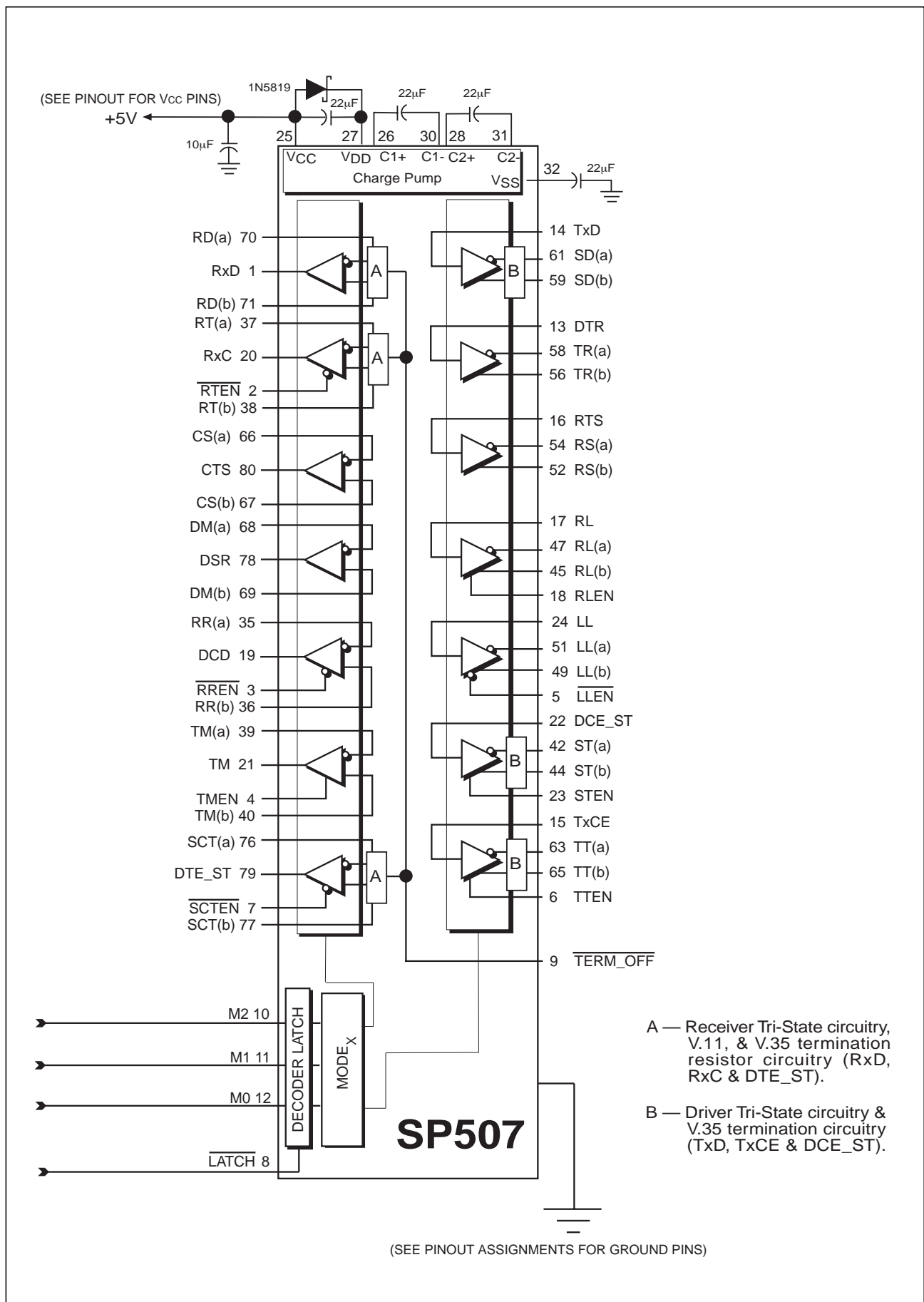

Figure 45. Typical Operating Circuit

## SP507 Driver Mode Selection

Pin Label	Mode	V.11	EIA-530A	EIA-530	X.21	V.35	RS-449	RS-232
<b>M2 - M0</b>	<b>111</b>	<b>000</b>	<b>001</b>	<b>010</b>	<b>011</b>	<b>100</b>	<b>101</b>	<b>110</b>
SD(a)	3-state	V.11-	V.11-	V.11-	V.11-	V.35- 	V.11-	V.28
SD(b)	3-state	V.11+	V.11+	V.11+	V.11+	V.35+ 	V.11+	3-state
TR(a)	3-state	V.11-	V.10	V.11-	V.11-	V.28	V.11-	V.28
TR(b)	3-state	V.11+	3-state	V.11+	V.11+	3-state	V.11+	3-state
RS(a)	3-state	V.11-	V.11-	V.11-	V.11-	V.28	V.11-	V.28
RS(b)	3-state	V.11+	V.11+	V.11+	V.11+	3-state	V.11+	3-state
RL(a)	3-state	V.11-	V.11-	V.11-	V.11-	V.28	V.11-	V.28
RL(b)	3-state	V.11+	V.11+	V.11+	V.11+	3-state	V.11+	3-state
LL(a)	3-state	V.10	V.10	V.10	V.10	V.28	V.10	V.28
LL(b)	3-state	3-state	3-state	3-state	3-state	3-state	3-state	3-state
ST(a)	3-state	V.11-	V.11-	V.11-	V.11-	V.35- 	V.11-	V.28
ST(b)	3-state	V.11+	V.11+	V.11+	V.11+	V.35+ 	V.11+	3-state
TT(a)	3-state	V.11-	V.11-	V.11-	V.11-	V.35- 	V.11-	V.28
TT(b)	3-state	V.11+	V.11+	V.11+	V.11+	V.35+ 	V.11+	3-state

Table 1. SP507 Driver Decoder Table

## SP507 Receiver Mode Selection





































Pin Label	Mode	V.11	EIA-530A	EIA-530	X.21	V.35	RS-449	RS-232
<b>M2 - M0</b>	<b>111</b>	<b>000</b>	<b>001</b>	<b>010</b>	<b>011</b>	<b>100</b>	<b>101</b>	<b>110</b>
RD(a)	>10kΩ to GND	V.11- 	V.11- 	V.11- 	V.11- 	V.35- 	V.11- 	V.28
RD(b)	>10kΩ to GND	V.11+ 	V.11+ 	V.11+ 	V.11+ 	V.35+ 	V.11+ 	>10kΩ to GND
RT(a)	>10kΩ to GND	V.11- 	V.11- 	V.11- 	V.11- 	V.35- 	V.11- 	V.28
RT(b)	>10kΩ to GND	V.11+ 	V.11+ 	V.11+ 	V.11+ 	V.35+ 	V.11+ 	>10kΩ to GND
CS(a)	>10kΩ to GND	V.11-	V.11-	V.11-	V.11-	V.28	V.11-	V.28
CS(b)	>10kΩ to GND	V.11+	V.11+	V.11+	V.11+	>10kΩ to GND	V.11+	>10kΩ to GND
DM(a)	>10kΩ to GND	V.11-	V.10	V.11-	V.11-	V.28	V.11-	V.28
DM(b)	>10kΩ to GND	V.11+	>10kΩ to GND	V.11+	V.11+	>10kΩ to GND	V.11+	>10kΩ to GND
RR(a)	>10kΩ to GND	V.11-	V.11-	V.11-	V.11-	V.28	V.11-	V.28
RR(b)	>10kΩ to GND	V.11+	V.11+	V.11+	V.11+	>10kΩ to GND	V.11+	>10kΩ to GND
TM(a)	>10kΩ to GND	V.10	V.10	V.10	V.10	V.28	V.10	V.28
TM(b)	>10kΩ to GND	>10kΩ to GND	>10kΩ to GND	>10kΩ to GND	>10kΩ to GND	>10kΩ to GND	>10kΩ to GND	>10kΩ to GND
SCT(a)	>10kΩ to GND	V.11- 	V.11- 	V.11- 	V.11- 	V.35- 	V.11- 	V.28
SCT(b)	>10kΩ to GND	V.11+ 	V.11+ 	V.11+ 	V.11+ 	V.35+ 	V.11+ 	>10kΩ to GND

Table 2. SP507 Receiver Decoder Table

MODE: V.11		
DRIVER/RECEIVER		
M2	M1	M0
0	0	0

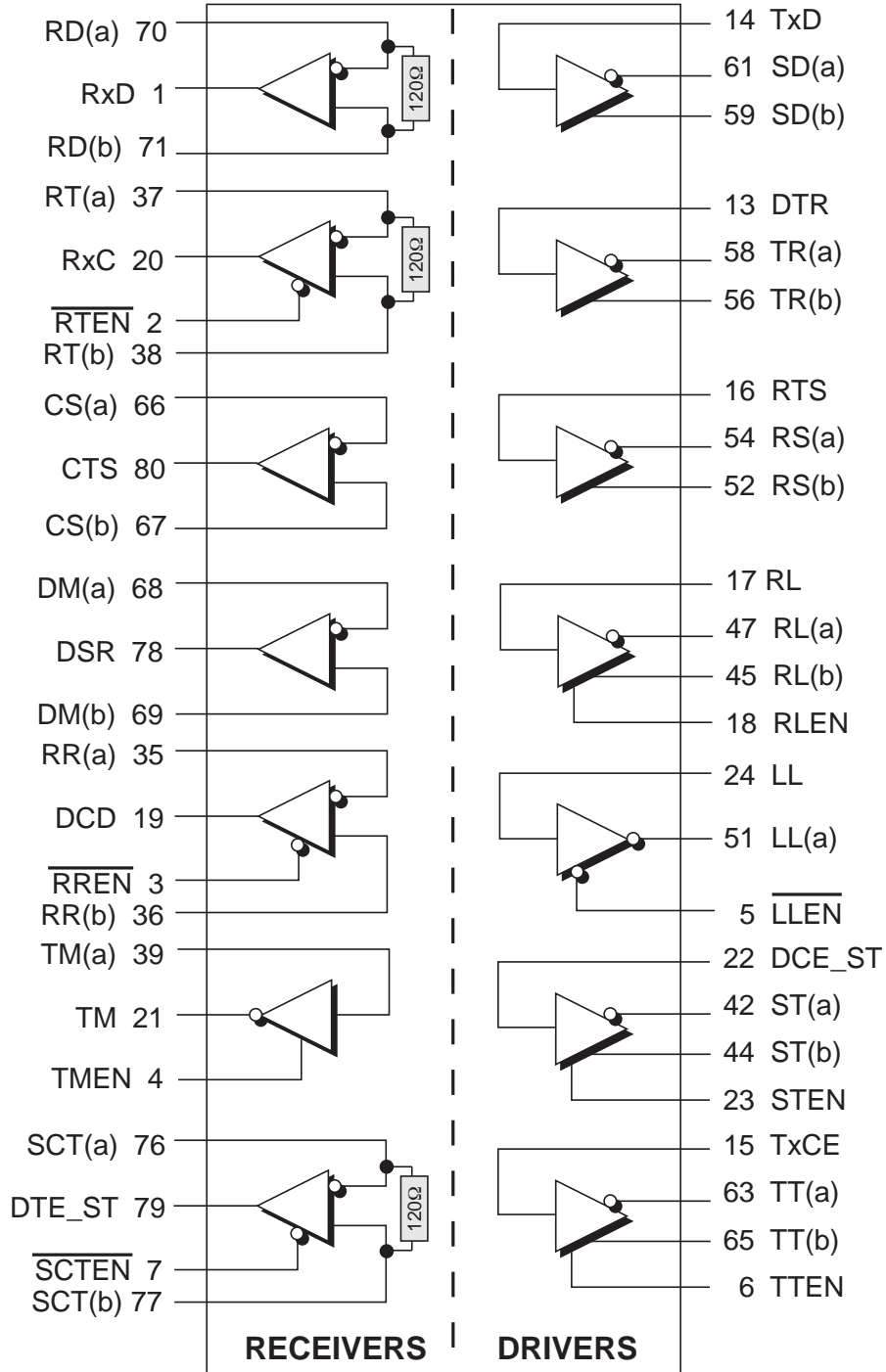

Figure 46. Mode Diagram - V.11

MODE: EIA-530A		
DRIVER/RECEIVER		
M2	M1	M0
0	0	1

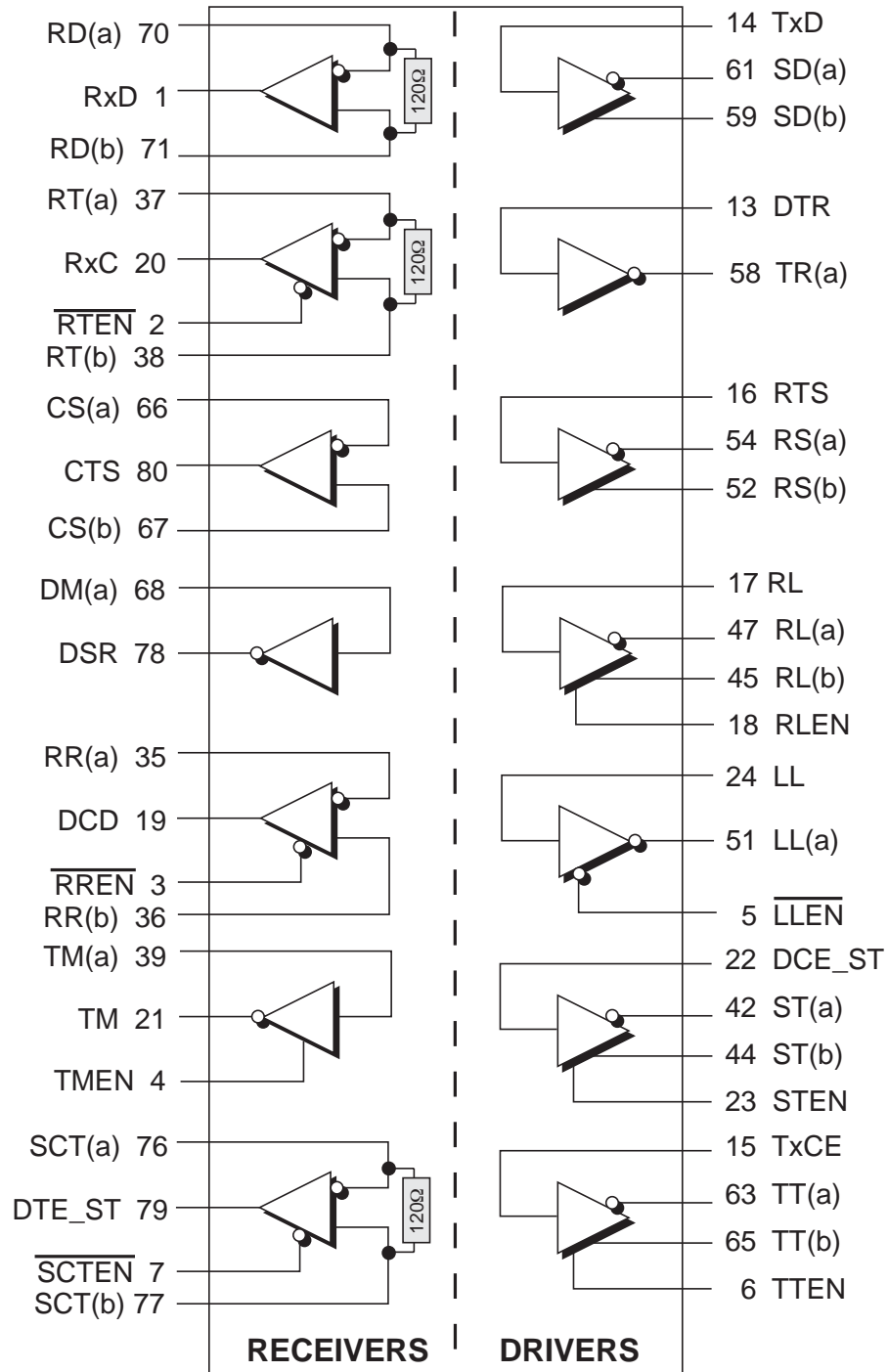

Figure 47. Mode Diagram – EIA-530A

MODE: EIA-530		
DRIVER/RECEIVER		
M2	M1	M0
0	1	0

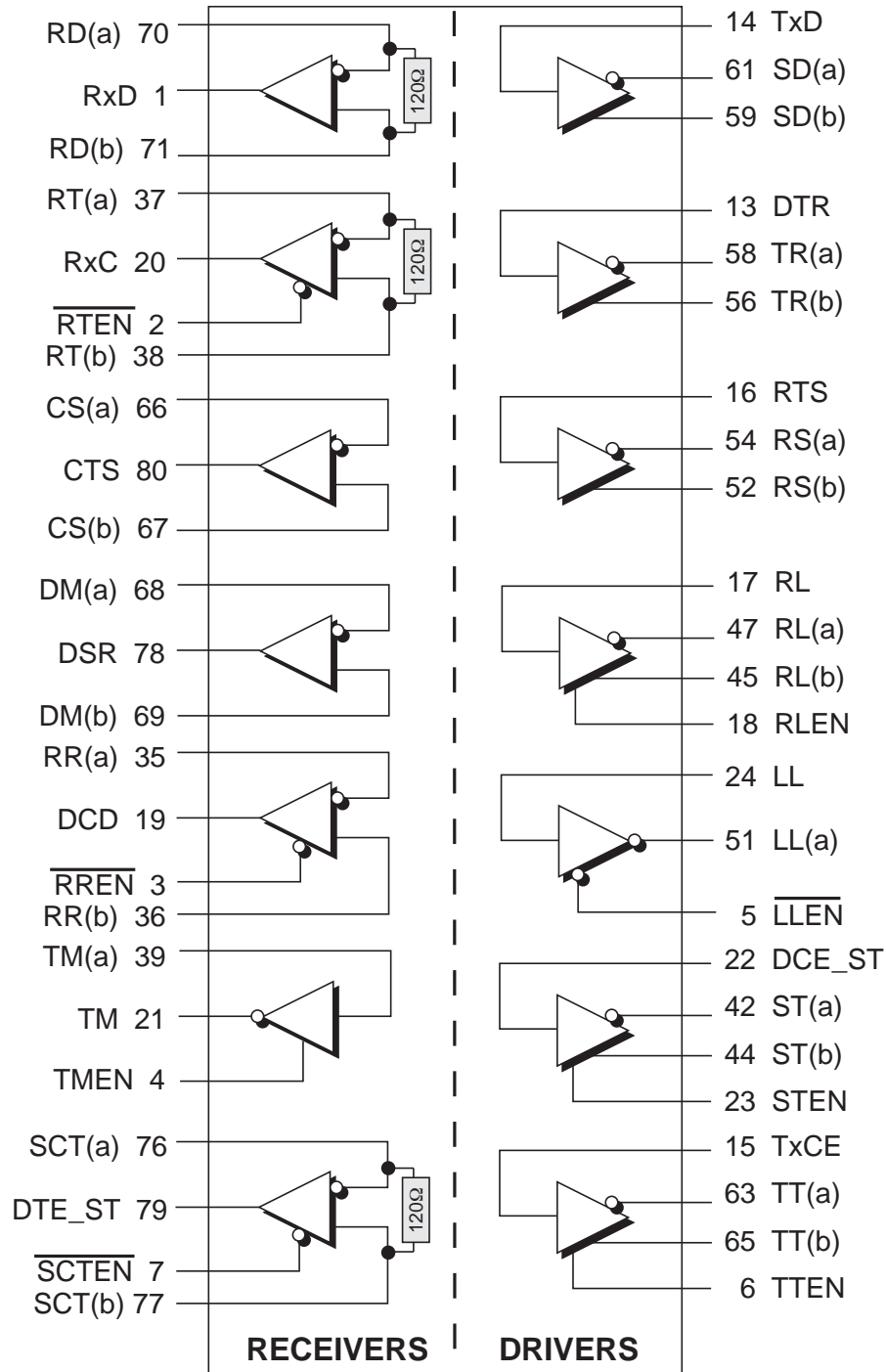

Figure 48. Mode Diagram – EIA-530

MODE: X.21		
DRIVER/RECEIVER		
M2	M1	M0
0	1	1

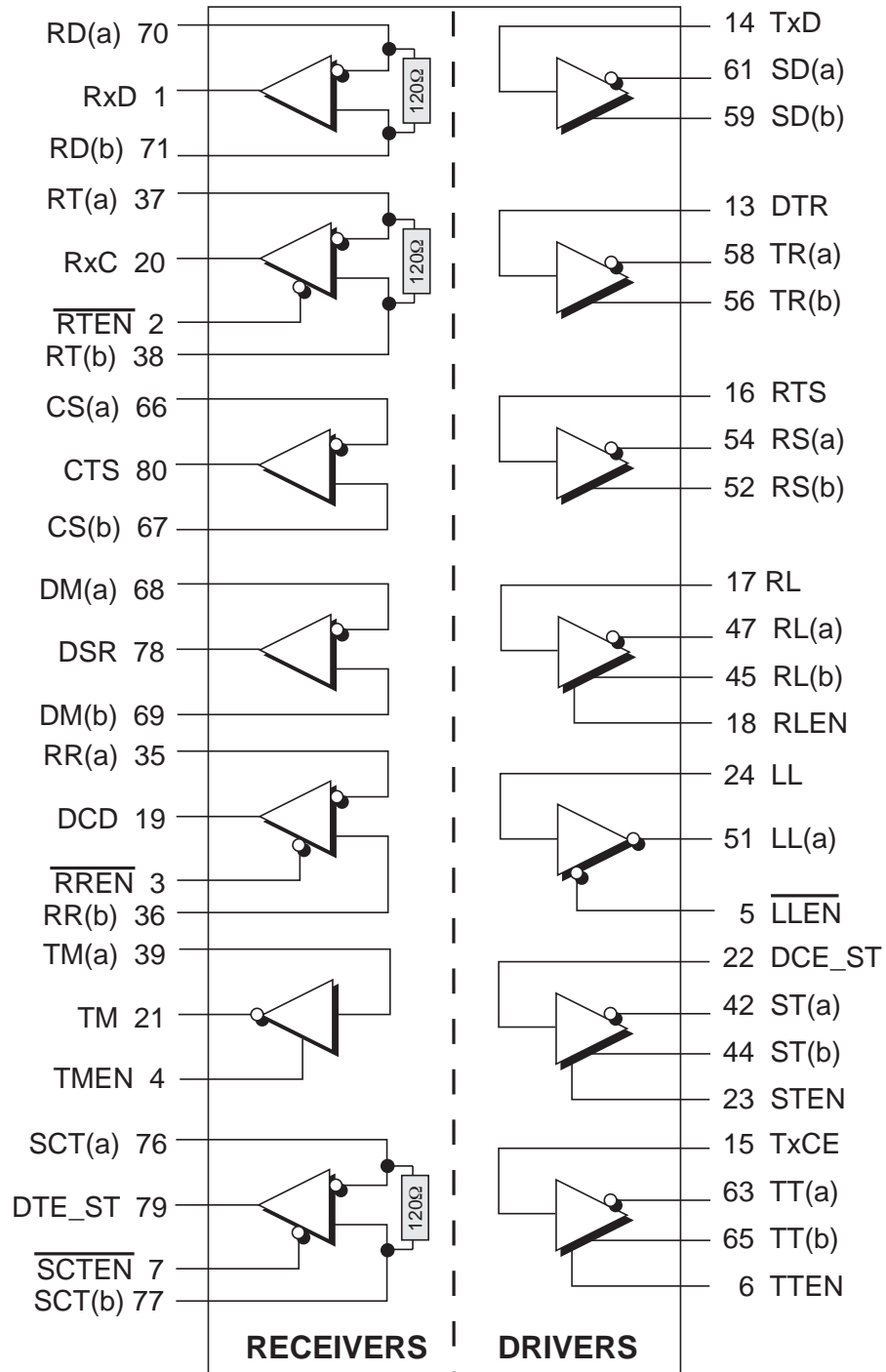

Figure 49. Mode Diagram – X.21

MODE: V.35		
DRIVER/RECEIVER		
M2	M1	M0
1	0	0

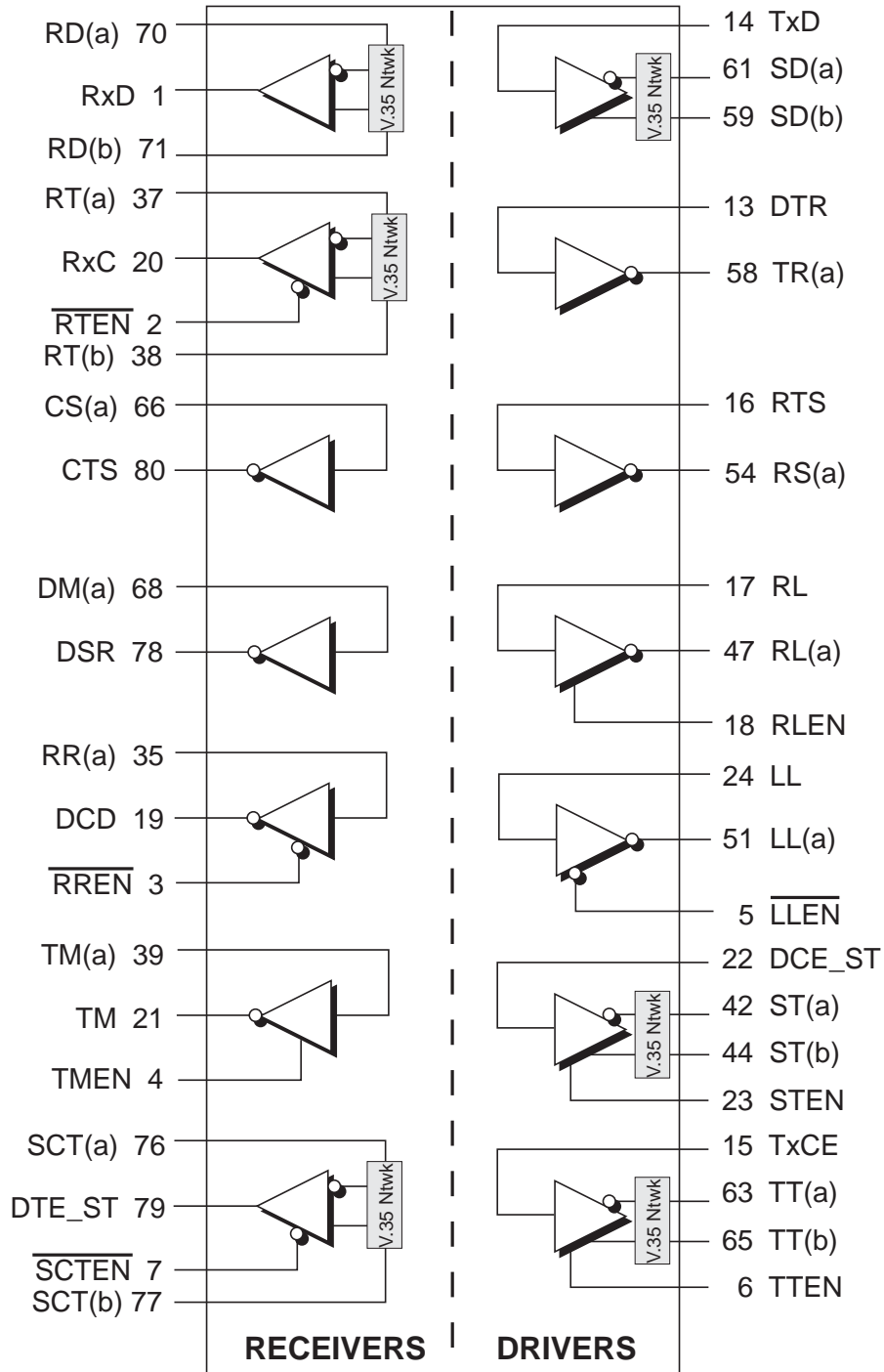

Figure 50. Mode Diagram – V.35



MODE: RS-449		
DRIVER/RECEIVER		
M2	M1	M0
1	0	1

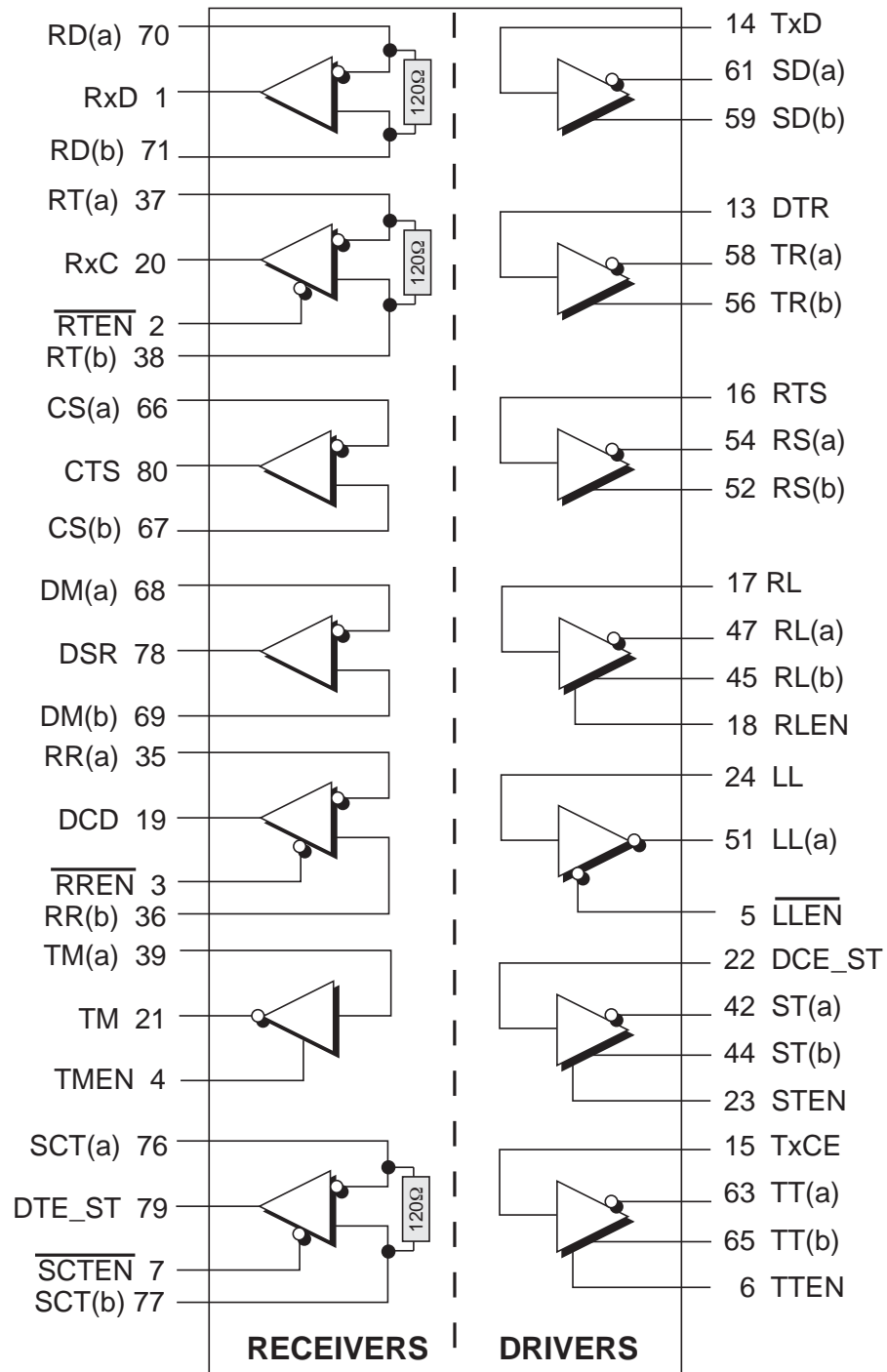

Figure 51. Mode Diagram – RS-449

MODE: RS-232 (V.28)		
DRIVER/RECEIVER		
M2	M1	M0
1	1	0

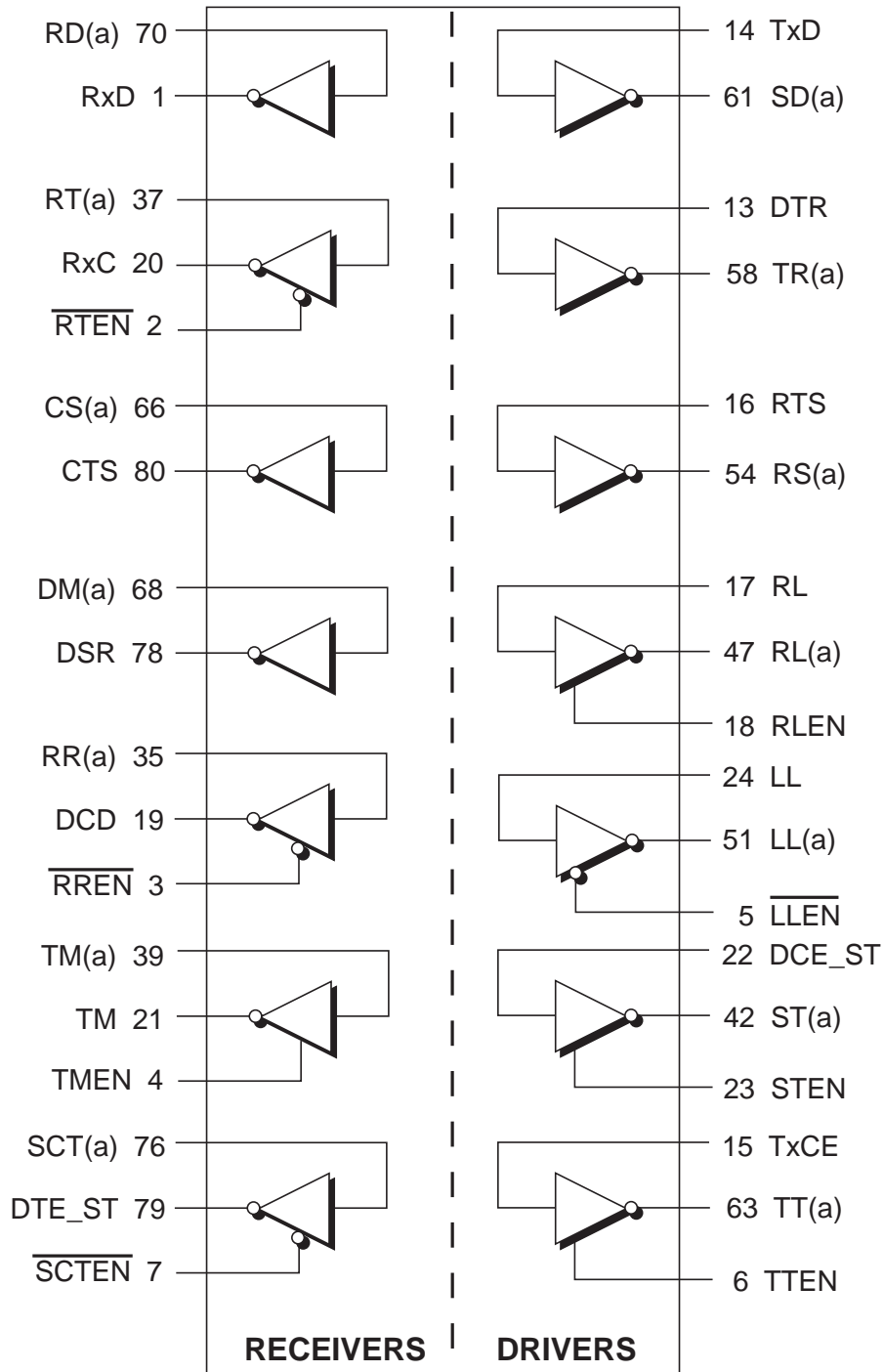
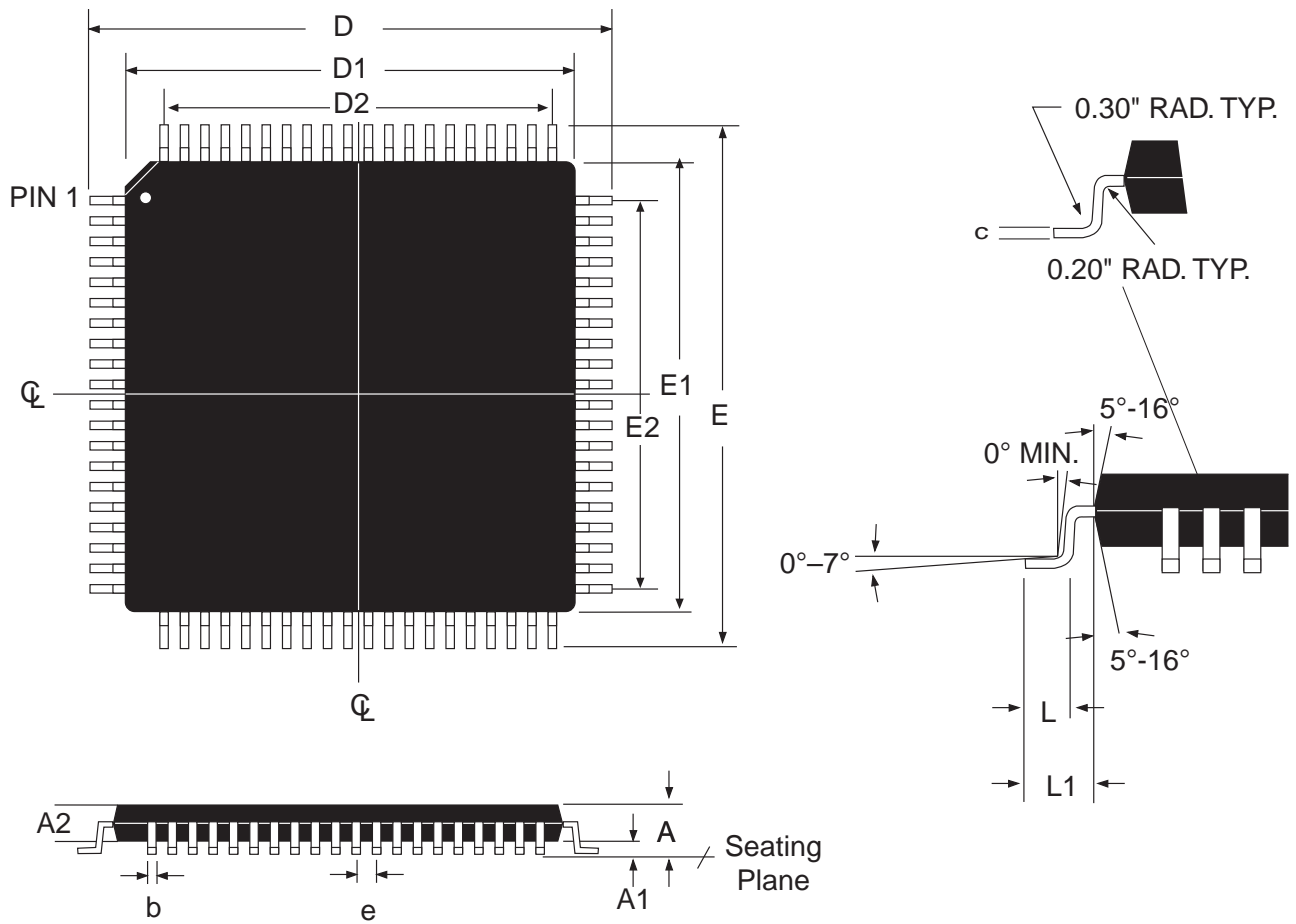

Figure 52. Mode Diagram – RS-232

**PACKAGE: 80 PIN MQFP**



DIMENSIONS Minimum/Maximum (mm)	80-PIN MQFP JEDEC MS-22 (BEC) Variation		
	MIN	NOM	MAX
A			2.45
A1	0.00		0.25
A2	1.80	2.00	2.20
b	0.22		0.40
D	17.20 BSC		
D1	14.00 BSC		
D2	12.35 REF		
E	17.20 BSC		
E1	14.00 BSC		
E2	12.35 REF		
e	0.65 BSC		
N	80		

COMMON DIMENTIONS			
SYMBL	MIN	NOM	MAX
c	0.11		23.00
L	0.73	0.88	1.03
L1	1.60 BASIC		

**80 PIN MQFP (MS-022 BC)**

## ORDERING INFORMATION

Model	Temperature Range	Package Types
SP507CF .....	0°C to +70°C .....	80-pin JEDEC (BE-2 Outline) MQFP

Please consult the factory for pricing and availability on a Tape-On-Reel option.

## REVISION HISTORY

DATE	REVISION	DESCRIPTION
1/27/04	A	Implemented tracking revision.



ANALOG EXCELLENCE

### Sipex Corporation

#### Headquarters and Sales Office

233 South Hillview Drive  
Milpitas, CA 95035  
TEL: (408) 934-7500  
FAX: (408) 935-7600

#### Sales Office

22 Linnell Circle  
Billerica, MA 01821  
TEL: (978) 667-8700  
FAX: (978) 670-9001  
e-mail: sales@sipex.com

Sipex Corporation reserves the right to make changes to any products described herein. Sipex does not assume any liability arising out of the application or use of any product or circuit described herein; neither does it convey any license under its patent rights nor the rights of others.