

Low-Cost Programmable Multi-Protocol Transceivers

- SP522 — 2 Drivers and 2 Receivers
- SP524 — 4 Drivers and 4 Receivers
- Driver and Receiver Tri-State Control
- Low-Cost WAN Solution
- Loopback Function for Diagnostics
- Software Selectable Interface Modes:
 - RS-232 (V.28), RS-423 (V.10)
 - RS-422 (V.11, X.21), RS-485

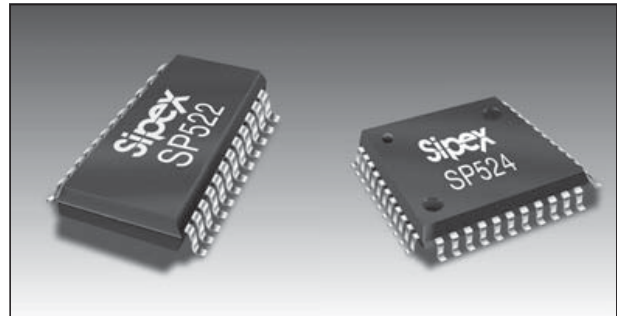

DESCRIPTION

The **SP522/524** is a monolithic device that supports three serial interface standards for Wide Area Network Connectivity. The **SP522/524** is ideally suited for multi-protocol designs that are cost and space sensitive. The **SP522/524** is fabricated using a low power BiCMOS process technology. Two (2) drivers and two (2) receivers for the **SP522** can be configured via software for any of the above interface modes at any time. The **SP524** offers two (2) additional drivers and two (2) additional receivers.

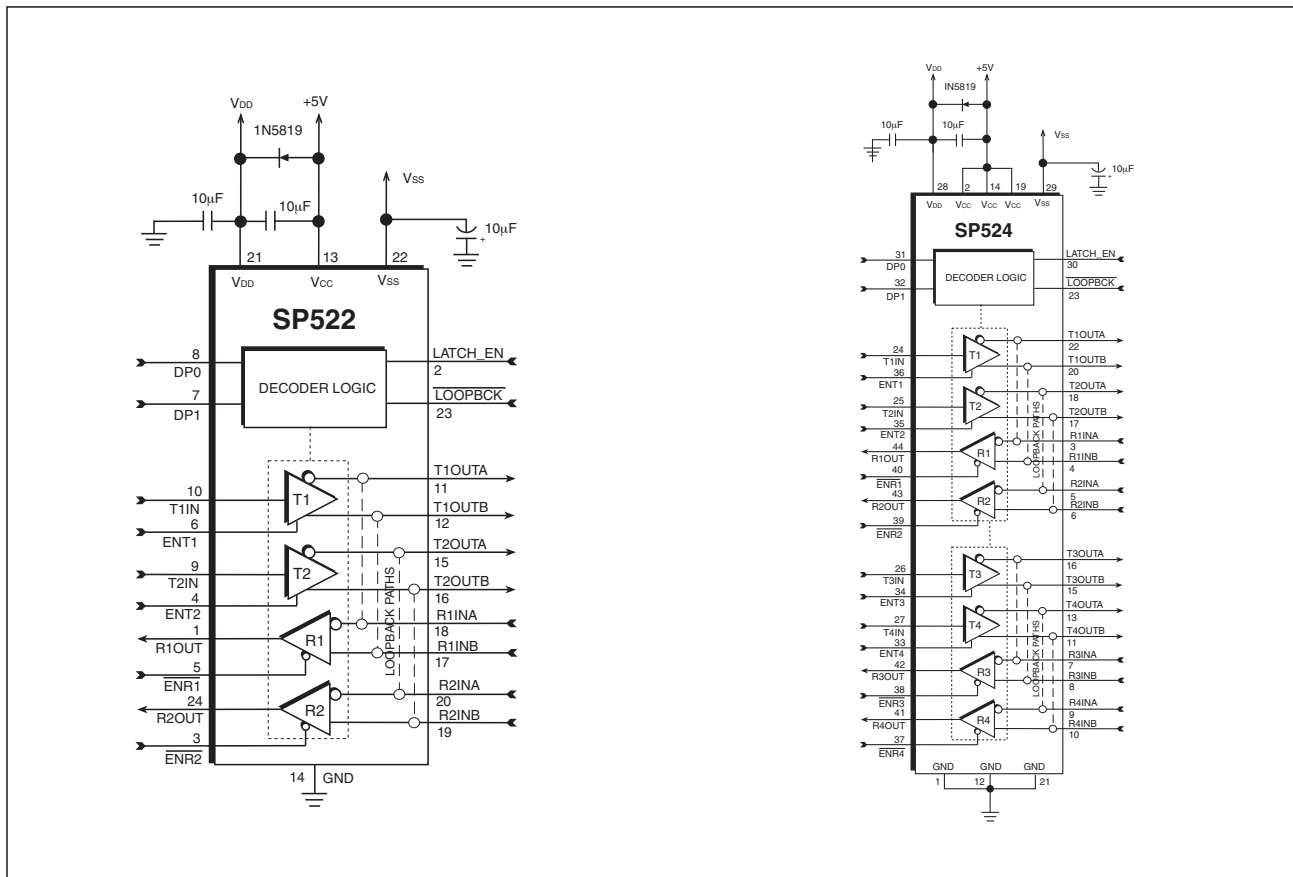

SPECIFICATIONS

Typical @ 25°C and nominal supply voltages unless otherwise noted.

	MIN.	TYP.	MAX.	UNITS	CONDITIONS
LOGIC INPUTS					
V_{IL}			0.8	Volts	
V_{IH}	2.0			Volts	
LOGIC OUTPUTS					
V_{OL}			0.4	Volts	$I_{OUT} = -3.2mA$
V_{OH}	2.4			Volts	$I_{OUT} = 1.0mA$
RS422 DRIVER					
TTL Input Levels					
V_{IL}	0		0.8	Volts	
V_{IH}	2.0			Volts	
Outputs					
Differential Output	± 2.0		± 5.0	Volts	$R = 50\Omega$; see Figure 1
Open Circuit Voltage, V_O			± 6.0	Volts	
Balance			± 0.4	Volts	$ V_T - \bar{V}_T $
Offset			+3.0	Volts	
Short Circuit Current			± 150	mA	$V_{out} = 0V$
Power Off Current			± 100	μA	$V_{CC} = 0V, V_{out} = \pm 0.25V$
Transition Time			40	nS	Rise/fall time, 10%-90%
Max. Transmission Rate	10			Mbps	$R_L = 100\Omega$
Propagation Delay					$T_A = +25^\circ C$
t_{PHL}		90	150	nS	$R_{DIFF} = 100\Omega$, Figures 3 & 5
t_{PLH}		90	150	nS	$R_{DIFF} = 100\Omega$, Figures 3 & 5
RS422 RECEIVER					
TTL Output Levels					
V_{OL}			0.4	Volts	
V_{OH}	2.4			Volts	
Input					
High Threshold	+0.3		+6.0	Volts	(a)-(b)
Low Threshold	-6.0		-0.3	Volts	(a)-(b)
Common Mode Range	-7.0		+7.0	Volts	
High Input Current					Refer to Rec. input graph
Low Input Current					Refer to Rec. input graph
Receiver Sensitivity			± 0.3	Volts	$V_{CM} = +7V$ to $-7V$
Input Impedance	4			k Ω	
Max. Transmission Rate	10			Mbps	
Propagation Delay					$T_A = +25^\circ C$
t_{PHL}		110	175	nS	Figures 3 & 7
t_{PLH}		110	175	nS	Figures 3 & 7
RS485 DRIVER					
TTL Input Levels					
V_{IL}			0.8	Volts	
V_{IH}	2.0			Volts	
Outputs					
Differential Output	± 1.5		± 5.0	Volts	$R = 27\Omega; C_L = 50pF$; see Fig. 1
Open Circuit Voltage, V_O			± 6.0	Volts	
Balance			± 0.2	Volts	$ V_T - \bar{V}_T $
Output Current	28.0			mA	$R_L = 54\Omega$
Short Circuit Current		± 200		mA	$V_{out} = -7V$ to $+7V$
Transition Time			40	nS	Rise/fall time, 10%-90%
Max. Transmission Rate	10			Mbps	$R_L = 54\Omega$
Propagation Delay					Figures 3 & 5; $T_A = +25^\circ C$
t_{PHL}		100	150	nS	$R_{DIFF} = 54\Omega, C_{RL} = 50pF$
t_{PLH}		100	150	nS	$R_{DIFF} = 54\Omega, C_{RL} = 50pF$

SPECIFICATIONS

Typical @ 25°C and nominal supply voltages unless otherwise noted.

	MIN.	TYP.	MAX.	UNITS	CONDITIONS
RS485 RECEIVER					
TTL Output Levels					
V_{OL}			0.4	Volts	
V_{OH}	2.4			Volts	
Input					
Common Mode Range	-7.0		+12.0	Volts	
High Input Current					Refer to Rec. input graph
Low Input Current					Refer to Rec. input graph
Receiver Sensitivity		±0.1		Volts	$V_{CM} = +12V$ to $-7V$
Input Impedance	12			k Ω	$V_{CM} = +12V$ to $-7V$
Max. Transmission Rate	10			Mbps	
Propagation Delay					$T_A = +25^\circ C$
t_{PHL}		110	175	nS	Figures 3 & 7
t_{PLH}		110	175	nS	Figures 3 & 7
RS232 DRIVER					
TTL Input Level					
V_{IL}			0.8	Volts	
V_{IH}	2.0			Volts	
Outputs					
High Level Output	+5.0		+15	Volts	$R_L = 3K\Omega$, $V_{IN} = 0.8V$
Low Level Output	-15.0		-5.0	Volts	$R_L = 3K\Omega$, $V_{IN} = 2.0V$
Open Circuit Voltage	-15		+15	Volts	
Short Circuit Current			±100	mA	$V_{out} = 0V$
Power Off Impedance	300			Ω	$V_{cc} = 0V$, $V_{out} = \pm 2.0V$
Slew Rate			30	V/ μs	$R_L = 3K\Omega$, $C_L = 50pF$, between +3V to -3V
Transition Time			1.5	μs	$R_L = 3K\Omega$, $C_L = 2500pF$
Max. Transmission Rate	120			Kbps	$R_L = 3K\Omega$, $C_L = 2500pF$
Propagation Delay					$T_A = +25^\circ C$
t_{PHL}		2	8	μs	$R_L = 3K\Omega$
t_{PLH}		2	8	μs	$R_L = 3K\Omega$
RS232 RECEIVER					
TTL Output Levels					
V_{OL}			0.4	Volts	
V_{OH}	2.4			Volts	
Input					
High Threshold		1.7	3.0	Volts	
Low Threshold	0.8	1.2		Volts	
Receiver Open Circuit Bias			+2.0	Volts	
Input Impedance	3	5	7	K Ω	
Max. Transmission Rate	120			Kbps	
Propagation Delay					$T_A = +25^\circ C$
t_{PHL}		0.2	1	μs	
t_{PLH}		0.2	1	μs	
RS423 DRIVER					
TTL Input Levels					
V_{IL}			0.8	Volts	
V_{IH}	2.0			Volts	
Output					
High Level Output	+3.6		+6.0	Volts	$V_{DD} = +5V$, $V_{SS} = -5V$
Low Level Output	-6.0		-3.6	Volts	$R_L = 450\Omega$, $V_T = 0.9 * V_{OC}$
Open Circuit Voltage	±4.0		±6.0	Volts	$R_L = 450\Omega$, $V_T = 0.9 * V_{OC}$
Short Circuit Current			±150	mA	$V_{OUT} = 0V$

SPECIFICATIONS (Continued)

Typical @ 25°C and nominal supply voltages unless otherwise noted.

	MIN.	TYP.	MAX.	UNITS	CONDITIONS
RS-423 DRIVER					
Power Off Current			±100	μA	$V_{CC} = 0V, V_{OUT} = \pm 0.25V$
Transition Time			1.0	μs	Rise/fall time, 10-90%
Max. Transmission Rate	120			Kbps	$R_L = 450\Omega$
Propagation Delay					$T_A = +25^\circ C$
t_{PHL}		2	8	μs	$R_L = 450\Omega$
t_{PLH}		2	8	μs	$R_L = 450\Omega$
RS423 RECEIVER					
TTL Output Levels					
V_{OL}	0		0.4	Volts	
V_{OH}	2.4			Volts	
Input					
High Threshold	+0.3		+7.0	Volts	
Low Threshold	-7.0		-0.3	Volts	
Common Mode Range	-7.0		+7.0	Volts	
High Input Current					Refer to Rec. input graph
Low Input Current					Refer to Rec. input graph
Receiver Sensitivity			±0.3	Volts	$V_{CM} = +7V$ to $-7V$
Input Impedance	4			KΩ	$V_{IN} = +10V$ to $-10V$
Max. Transmission Rate	120			Kbps	
Propagation Delay					$T_A = +25^\circ C$
t_{PHL}		0.5	1	μs	
t_{PLH}		0.5	1	μs	
POWER REQUIREMENTS					
V_{CC}	+4.75	+5.0	+5.25	Volts	
V_{DD}	+9.5	+10.0	+10.5	Volts	
V_{SS}	-9.5	-10.0	-10.5	Volts	
I_{CC}		4		mA	$V_{CC} = +5V; DP0=DP1=0V$
I_{DD}		10		mA	$V_{DD} = +10V; DP0=DP1=0V$
I_{SS}		10		mA	$V_{SS} = -10V; DP0=DP1=0V$
ENVIRONMENTAL AND MECHANICAL					
Operating Temperature Range	0		+70	°C	
Storage Temperature Range	-65		+150	°C	
Package	24-pin SOIC, 24-pin SSOP, 44-pin QFP				

RECEIVER INPUT GRAPHS

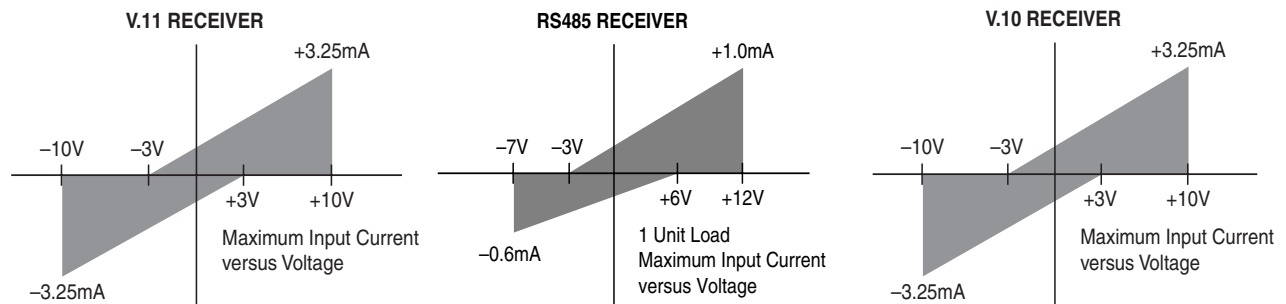

ABSOLUTE MAXIMUM RATINGS

These are stress ratings only and functional operation of the device at these ratings or any other above those indicated in the operation sections of the specifications below is not implied. Exposure to absolute maximum rating conditions for extended periods of time may affect reliability.

V_{CC}	+7V
V_{DD}	+12V
V_{SS}	-12V
Input Voltages	
Logic.....	-0.5V to ($V_{CC}+0.5V$)
Drivers.....	-0.5V to ($V_{CC}+0.5V$)
Receivers.....	$\pm 30V @ \leq 100mA$
Outputs Voltages	
Logic.....	-0.5V to ($V_{CC}+0.5V$)
Drivers.....	$\pm 15V$
Receivers.....	-0.5V to ($V_{CC}+0.5V$)
Storage Temperature.....	-65°C to +150°C
Power Dissipation.....	2000mW



CAUTION:
ESD (ElectroStatic Discharge) sensitive device. Permanent damage may occur on unconnected devices subject to high energy electrostatic fields. Unused devices must be stored in conductive foam or shunts. Personnel should be properly grounded prior to handling this device. The protective foam should be discharged to the destination socket before devices are removed.

OTHER AC CHARACTERISTICS

(Typical @ 25°C and nominal supply voltages unless otherwise noted)

PARAMETER	MIN.	TYP.	MAX.	UNITS	CONDITIONS
DRIVER DELAY TIME FROM ENABLE MODE TO TRI-STATE MODE					
SINGLE-ENDED MODE (RS-232, RS-423)					
t_{PZL} ; Enable to Output low		600		ns	3K Ω pull-up to output
t_{PZH} ; Enable to Output high		300		ns	3K Ω pull-down to output
t_{PLZ} ; Disable from Output low		300		ns	5V to input
t_{PHZ} ; Disable from Output high		900		ns	GND to input
DIFFERENTIAL MODE (RS-422, RS-485)					
t_{PZL} ; Enable to Output low		100		ns	$C_L = 100pF$, Fig. 4 & 6; S_1 closed
t_{PZH} ; Enable to Output high		120		ns	$C_L = 100pF$, Fig. 4 & 6; S_2 closed
t_{PLZ} ; Disable from Output low		100		ns	$C_L = 15pF$, Fig. 4 & 6; S_1 closed
t_{PHZ} ; Disable from Output high		160		ns	$C_L = 15pF$, Fig. 4 & 6; S_2 closed
RECEIVER DELAY TIME FROM ENABLE MODE TO TRI-STATE MODE					
SINGLE-ENDED MODE (RS-232, RS-423)					
t_{PZL} ; Enable to Output low		125		ns	3K Ω pull-up to output
t_{PZH} ; Enable to Output high		120		ns	3K Ω pull-down to output
t_{PLZ} ; Disable from Output low		90		ns	5V to input
t_{PHZ} ; Disable from Output high		90		ns	GND to input
DIFFERENTIAL MODE (RS-422, RS-485)					
t_{PZL} ; Enable to Output low		125		ns	$C_{RL} = 15pF$, Fig. 2 & 8; S_1 closed
t_{PZH} ; Enable to Output high		120		ns	$C_{RL} = 15pF$, Fig. 2 & 8; S_2 closed
t_{PLZ} ; Disable from Output low		90		ns	$C_{RL} = 15pF$, Fig. 2 & 8; S_1 closed
t_{PHZ} ; Disable from Output high		90		ns	$C_{RL} = 15pF$, Fig. 2 & 8; S_2 closed

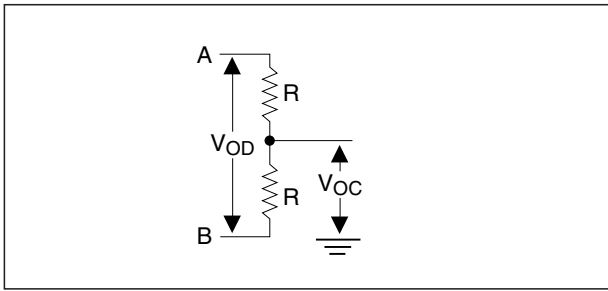

Figure 1. Driver DC Test Load Circuit

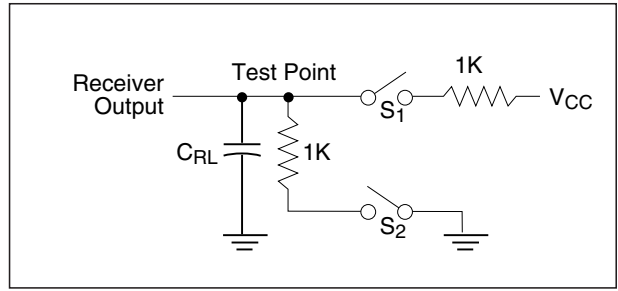

Figure 2. Receiver Timing Test Load Circuit

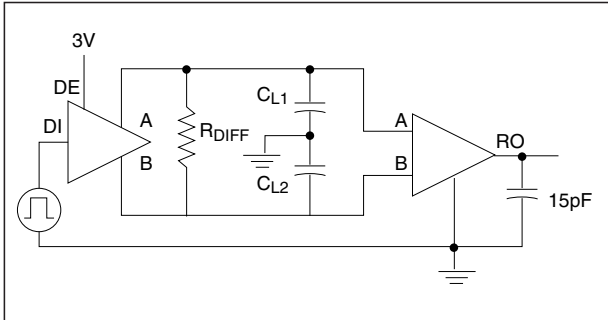

Figure 3. Driver/Receiver Timing Test Circuit

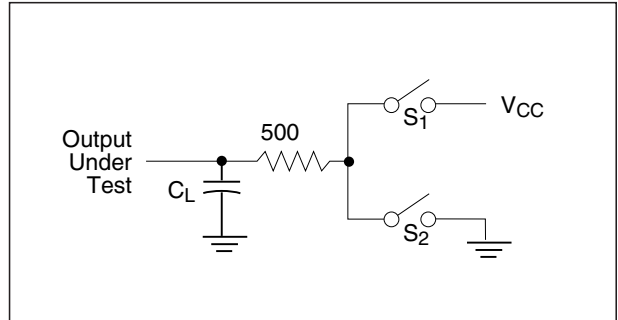

Figure 4. Driver Timing Test Load #2 Circuit

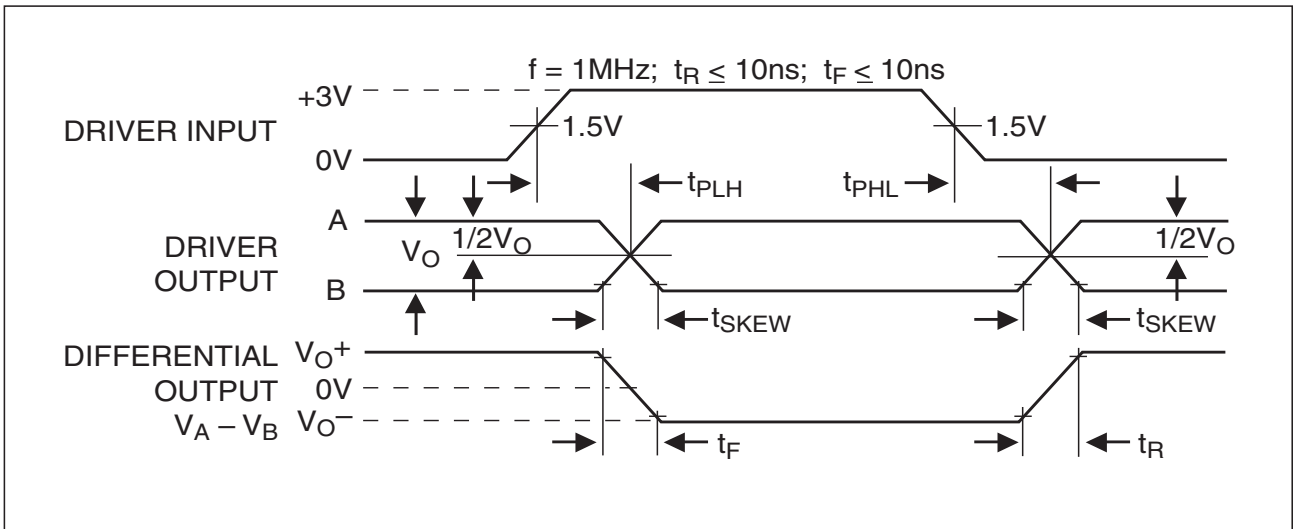

Figure 5. Driver Propagation Delays

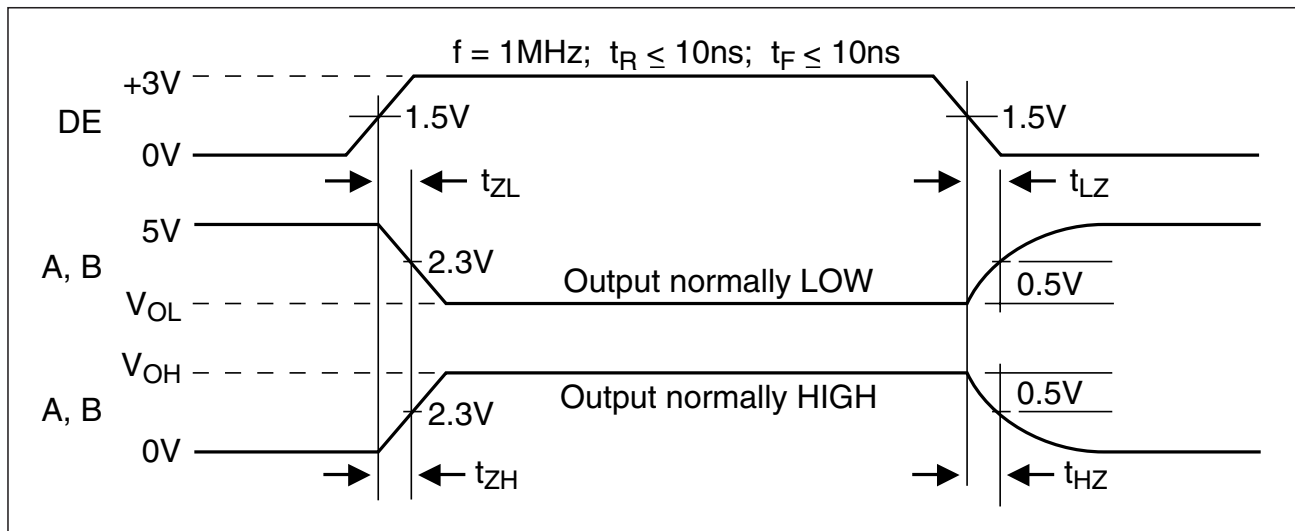

Figure 6. Driver Enable and Disable Times

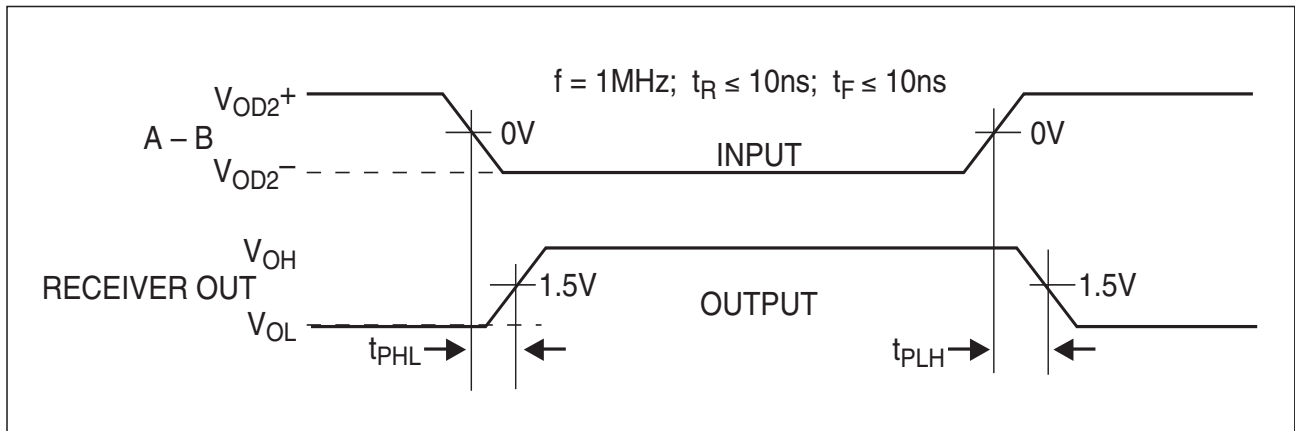

Figure 7. Receiver Propagation Delays

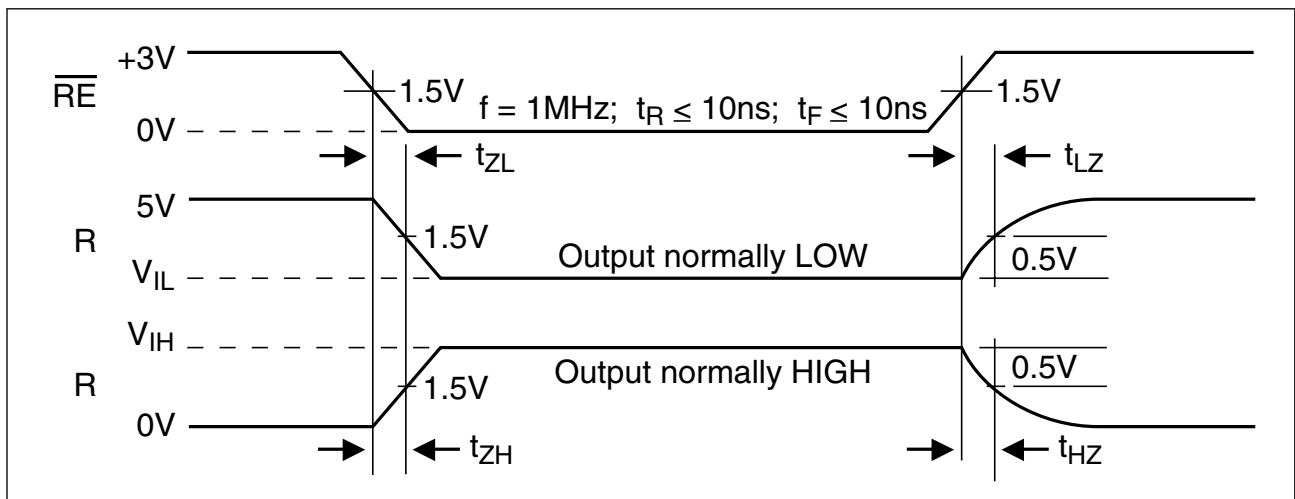
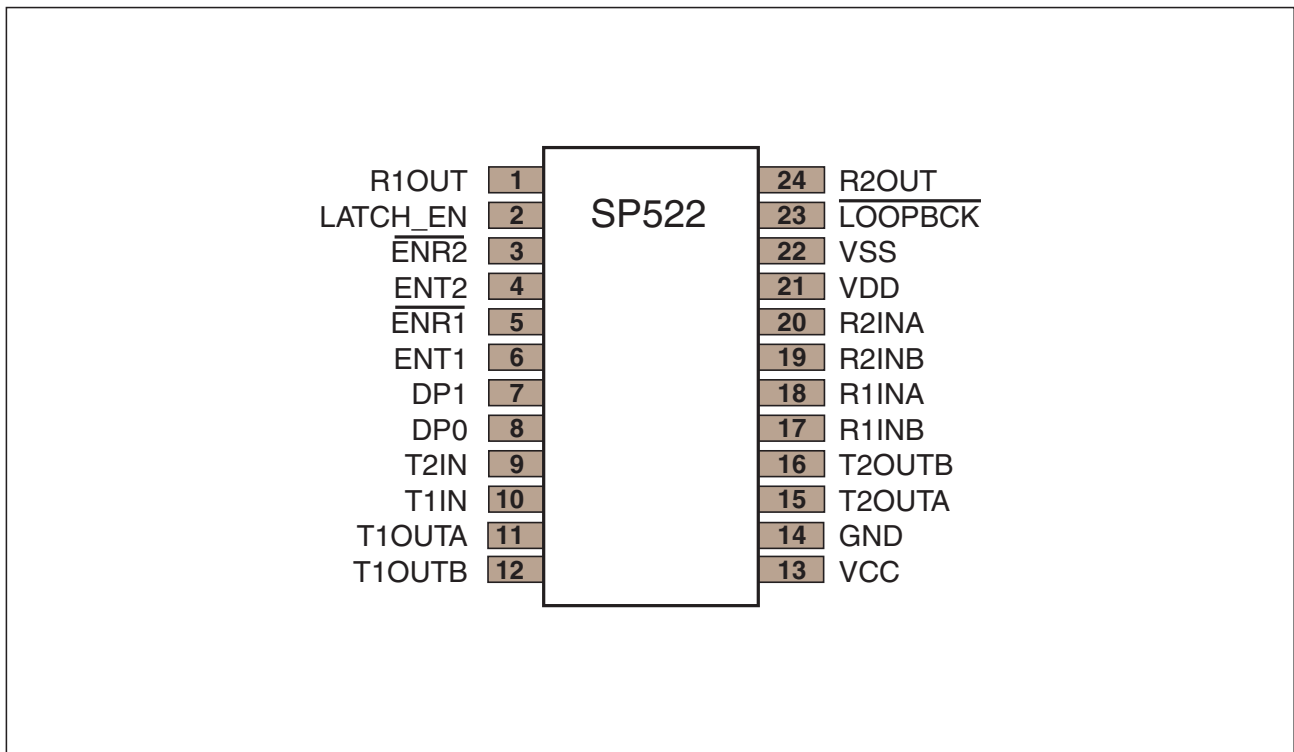
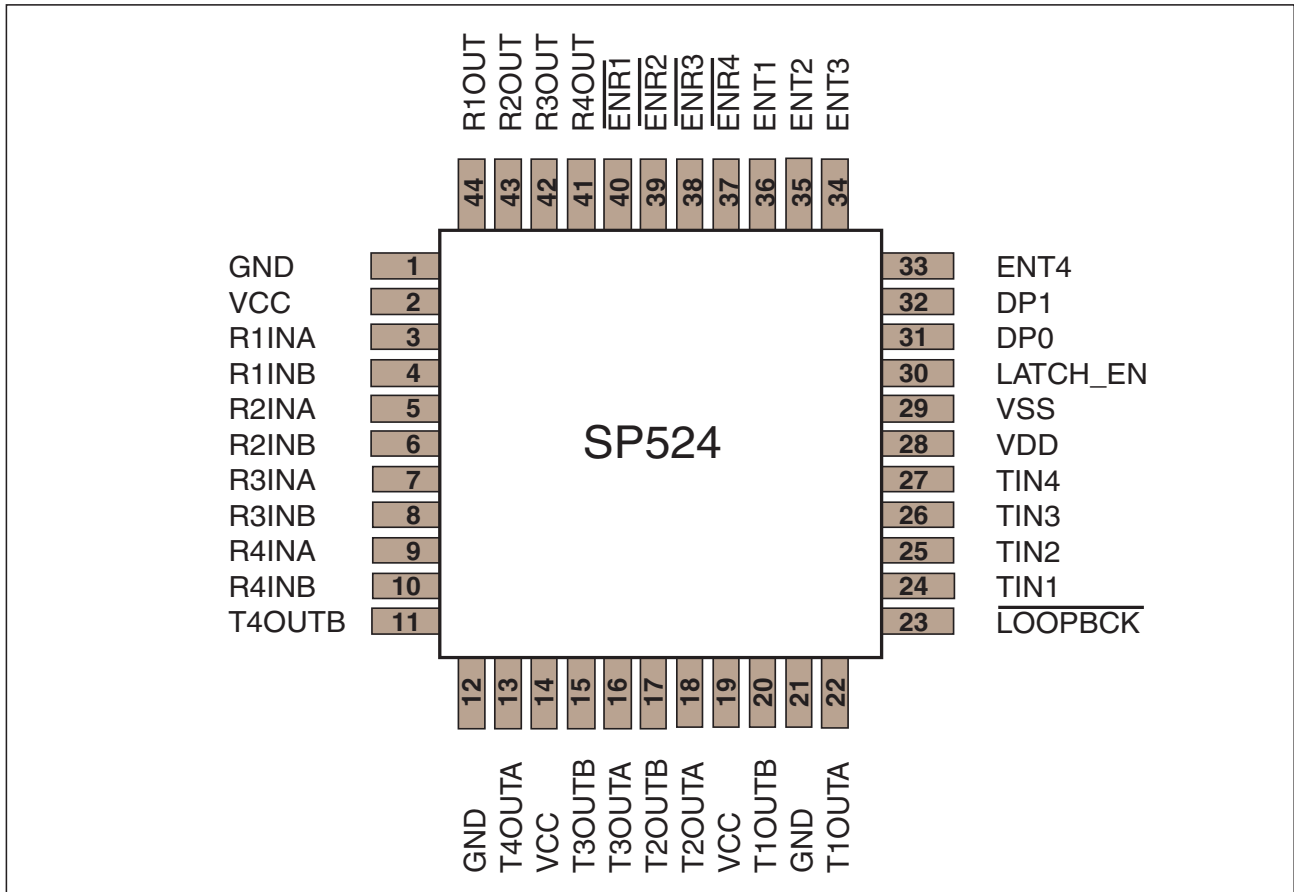

Figure 8. Receiver Enable and Disable Times

PINOUT (24-PIN SOIC & SSOP)



PINOUT (44-PIN QFP)



FEATURES

The **SP522** and **SP524** is a highly integrated serial transceiver that offers programmability between interface modes through software control. The **SP522** and **SP524** offers the hardware interface modes for RS-232 (V.28), RS-422A (V.11), RS-423 (V.10), and RS-485. The interface mode selection is done via two control pins. The **SP522** contains two (2) independent drivers and two (2) independent receivers. The **SP524** is basically two **SP522** functions on one silicon, thus having four (4) drivers and four (4) receivers.

The **SP522/SP524** is ideally suited for low-cost wide area network connectivity and other multi-protocol applications. Based on our previous multi-mode SP500 family, **Sipex** has allocated specific transceiver cells or "building blocks" from the SP503 and created the **SP522**. The "building block" concept is that these small transceiver cells can be packaged to offer a simple low-cost solution to networking applications that need only two to four interface modes. The **SP522** can be connected in series to build multiple channels needed for the specific application. **Sipex** has conveniently doubled the **SP522** transceiver cell into the **SP524** on a single silicon. For example in a 8-channel application requiring eight transceivers, the design can be implemented using two **SP524** devices. The **SP522** and **SP524** can also be implemented in series with our SP500 family. An application needing 9-channels can use the SP504 containing seven (7) transceivers with the **SP522**.

THEORY OF OPERATION

The **SP522** and **SP524** are simply made up of the drivers, receivers, and decoder. The devices operate on three (3) power supplies; V_{CC} at +5V, V_{DD} at +10V, and V_{SS} at -10V. Each of these circuit blocks are described in more detail below.

Drivers

The **SP522** has two (2) enhanced independent drivers. Control for the mode selection is done via a two-bit control word into DP0 and DP1. The drivers are pre-arranged such that for each mode of operation, the relative position and

functionality of the drivers are set up to accommodate the selected interface mode. As the mode of the drivers is changed, the electrical characteristics will change to support the required signal levels. The mode of each driver in the different interface modes that can be selected is shown in *Figures 10 to 13*.

There are three basic types of driver circuits — RS-232, RS-423, and RS-485.

The RS-232 drivers output single-ended signals with a minimum of $\pm 5V$ (with $3K\Omega$ and $2500pF$ loading), and can operate up to 120Kbps. The RS-232 drivers are used in RS-232 mode for all signals, and also in V.35 mode where they are used as the control line signals such as DTR and RTS.

The RS-423 drivers are also single-ended signals with a minimum voltage output of $\pm 3.6V$ (with 450Ω loading) and can operate up to 120Kbps. Open circuit V_{OL} and V_{OH} measurements are $\pm 4.0V$ to $\pm 6.0V$ when supplying $\pm 5V$ to V_{DD} and V_{SS} . The RS-423 drivers can be used in RS-449, EIA-530, EIA-530A and V.36 applications as Category II signals from each of their corresponding specifications.

The third type of driver produces a differential signal that can maintain RS-485, $\pm 1.5V$ differential output levels with a worst case load of 54Ω . The signal levels and drive capability of the RS-485 drivers allow the drivers to also support RS-422 (V.11) requirements of $\pm 2V$ differential output levels with 100Ω loads. The RS-422 drivers can be used in RS-449, EIA-530, EIA-530A and V.36 applications as Category I signals which are used for clock and data.

The drivers also have separate enable pins which makes the **SP522/SP524** helpful for half-duplex applications. The enable pins will tri-state the drivers when the ENT1 and ENT2 pins are at a logic low ("0"). For the **SP524**, ENT3 and ENT4 are used for the two additional drivers. During tri-stated conditions, the driver outputs will be at a high impedance state.

Unused driver inputs can be left floating; pull-up resistors to +5V is internally connected on the inputs so that the output is at a logic low ("0"). For differential drivers, the non-inverting output will be at a logic high ("1").

Receivers

The **SP522** has two (2) independent receivers which can be programmed for the different interface modes. Control for the mode selection is done by DP0 and DP1.

Like the drivers, the receivers are pre-arranged for the specific requirements of the interface. As the operating mode of the receivers is changed, the electrical characteristics will change to support the required interface. *Figures 10 to 13* show the mode of each receiver in the different interface modes that can be selected.

There are three basic types of receiver circuits — RS-232, RS-423, and RS-485.

The RS-232 receiver is a single-ended input with a threshold of 0.8V to 3.0V. The RS-232 receiver has an operating voltage range of $\pm 15V$ and can receive signals up to 120Kbps. The input sensitivity complies with EIA-RS-232 and V.28 at +3V to -3V. The input impedance is 3k Ω to 7k Ω .

The RS-423 receivers are also single-ended but have an input threshold as low as $\pm 300mV$. The input impedance is guaranteed to be greater than 4K Ω , with an operating voltage range of $\pm 7V$. The RS-423 receivers can operate up to 120Kbps. RS423 receivers can be used in RS-449, EIA530, EIA-530A and V.36 applications as Category II signals as indicated by their corresponding specifications.

The third type of receiver is a differential which supports RS-485. The RS-485 receiver has an input impedance of 15K Ω and a differential threshold of $\pm 300mV$. Since the characteristics of an RS-422 (V.11) receiver are actually subsets of RS-485, the receivers for RS-422 requirements are covered by the RS-485 receivers. RS-422 receivers are used in applications for RS-449, EIA530, EIA-530A and V.36 as Category I signals for receiving clock, data, and some control line signals. The differential receivers can receive data up to 10Mbps.

All receivers include a fail-safe feature that output a known logic state when the receiver inputs are unconnected. For single-ended RS-232 receivers, there are internal 5k Ω pull-down resistors on the inputs which produces a logic high ("1") at the receiver outputs. The single-ended RS-423 receivers produce a logic low ("0") on the output when the inputs are open. This is due to a pull-up device connected to the input. The differential receivers have the same internal pull-up device on the non-inverting input which produces a logic high ("1") at the receiver output.

The receivers also have enable pins which allow for convenient half-duplex configurations. The receivers are tri-stated when the $\overline{ENR1}$ and $\overline{ENR2}$ pins are at a logic high ("1"). For the **SP524**, $\overline{ENR3}$ and $\overline{ENR4}$ are used for the additional two receivers.

In addition to the separate enable lines on each transceiver, there is a latch enable pin, LATCH_EN, which is used for enabling and disabling the decoder control inputs (DP0, DP1) and transceiver enable pins. This pin will default to a logic high ("1") if not being used.

Loopback

The **SP522** and **SP524** contain a loopback feature that allows the driver outputs to "loopback" to the receiver inputs for diagnostic testing in the application. The loopback function is activated when the $\overline{LOOPBCK}$ pin is low. When in loopback mode, the driver outputs are tri-stated and the receiver inputs are deactivated. The receiver input impedance while in loopback will be a minimum of 12k Ω . The loopback function can be initiated during any mode of operation, RS-232, RS-423 or RS-422. The travel path of the transceivers in loopback is shown on *Figure 9*. The loopback function overrides the separate enable pins for the drivers or receivers. When $\overline{LOOPBCK}$ is at a logic low ("0"), the device will be configured in loopback regardless whether the transceiver is enabled or disabled. If the loopback function is not required, the $\overline{LOOPBCK}$ pin will default to a logic high ("1") state.

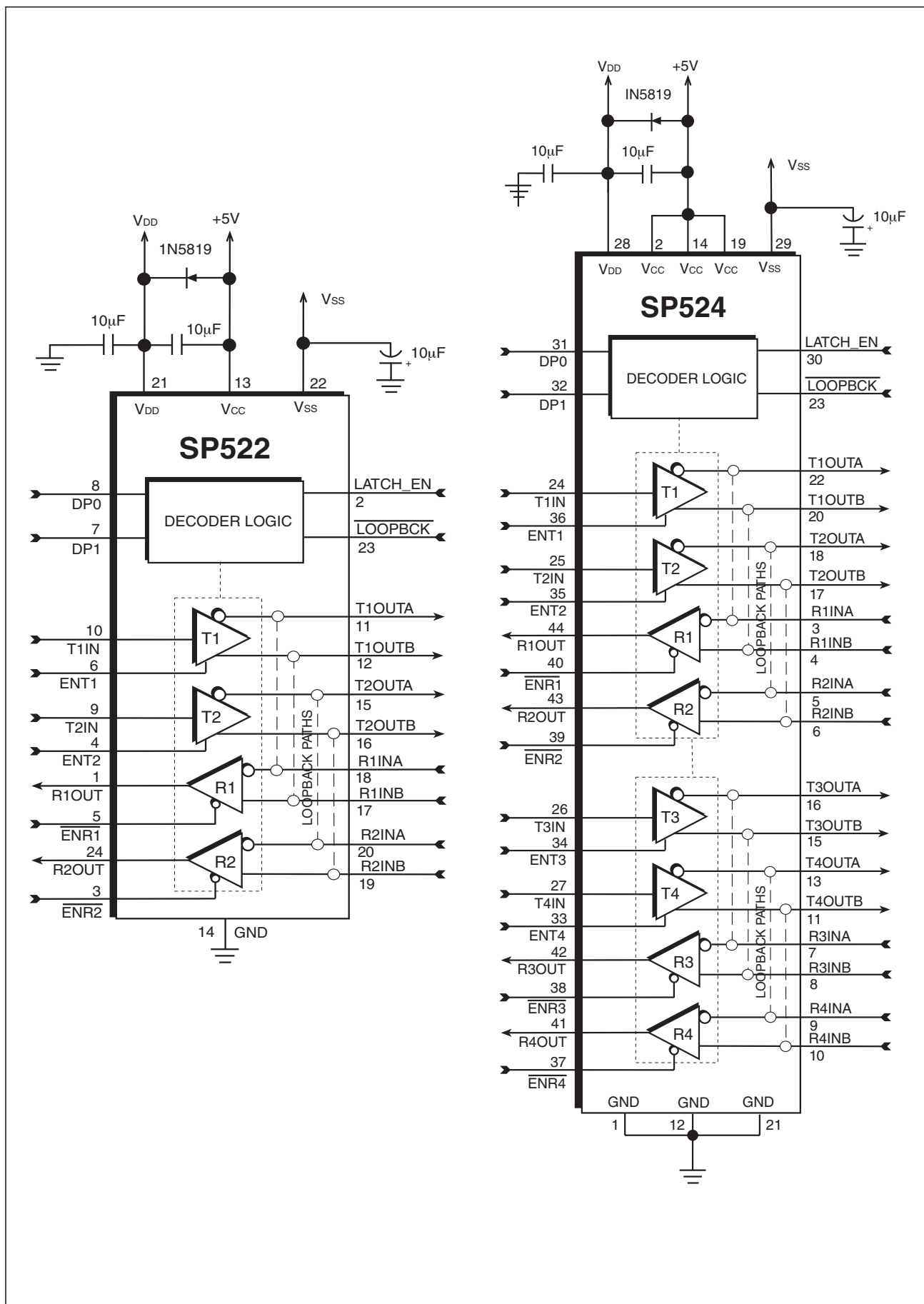
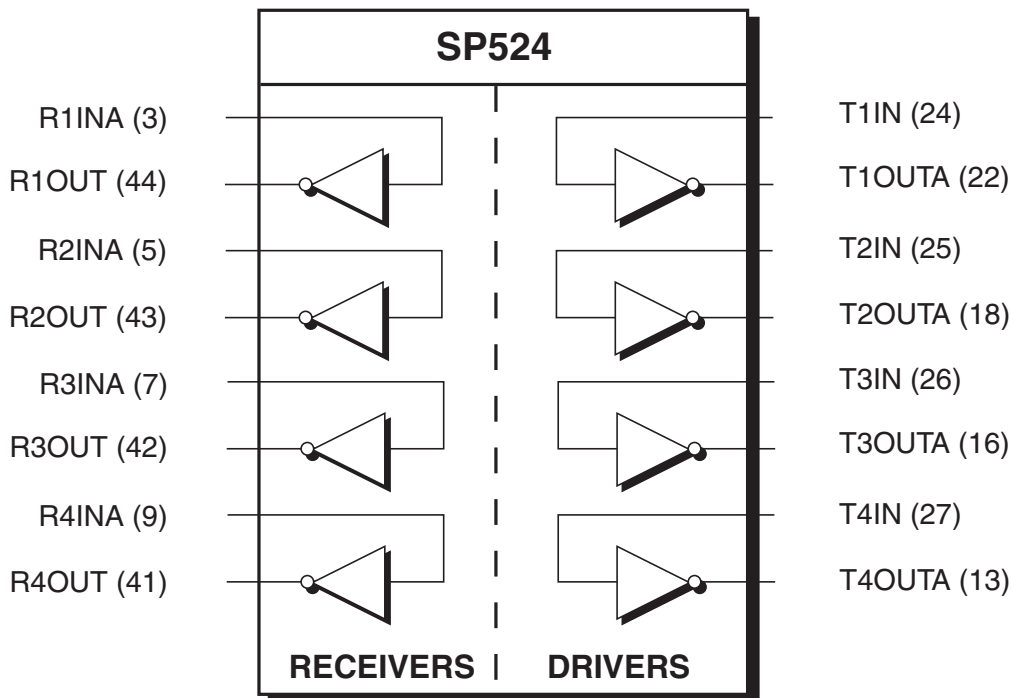
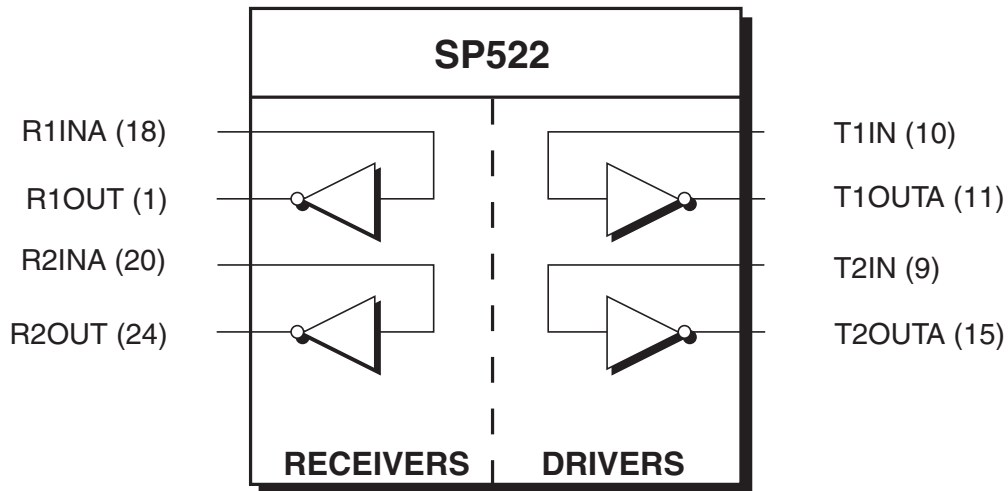

Figure 9. Typical Operating Circuit, SP522 and SP524

MODE: RS232			
DRIVER		RECEIVER	
DP0	DP1	DP0	DP1
1	0	1	0



LATCH_EN	LOOPBCK	ENT _x	ENR _x
1	1	1	0

Figure 10. Mode Diagram — RS232

MODE: RS423			
DRIVER		RECEIVER	
DP0	DP1	DP0	DP1
1	1	1	1

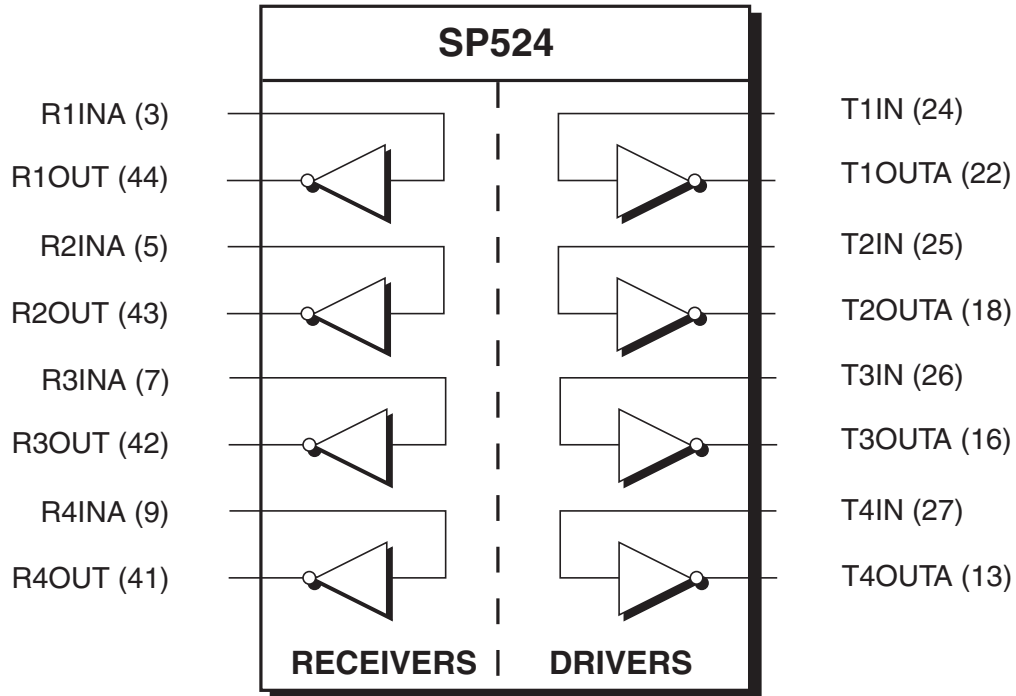
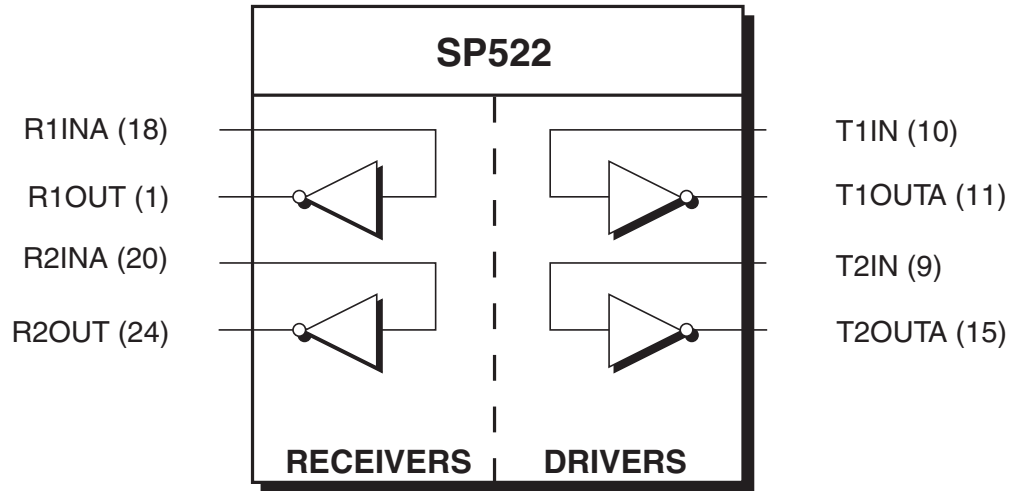

LATCH_EN	LOOPBCK	ENT _x	ENR _x
1	1	1	0

Figure 11. Mode Diagram — RS423

MODE: RS422/485			
DRIVER		RECEIVER	
DP0	DP1	DP0	DP1
0	1	0	1

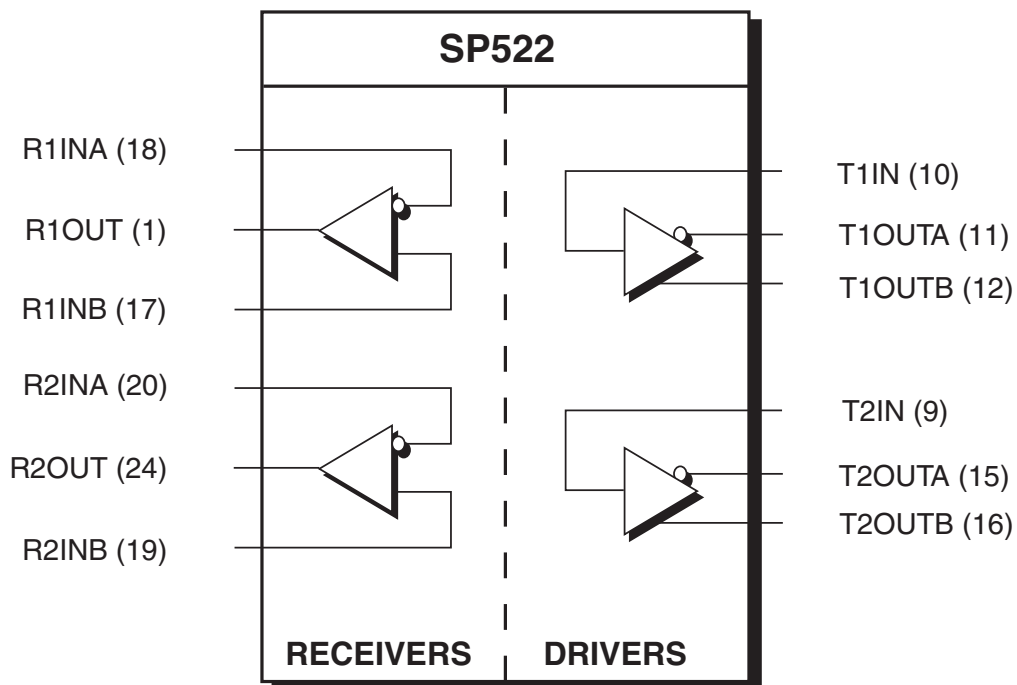

LATCH_EN	$\overline{\text{LOOPBCK}}$	ENT _x	$\overline{\text{ENR}}_x$
1	1	1	0

Figure 12. Mode Diagram — RS422/RS485 for the SP522

MODE: RS422/485			
DRIVER		RECEIVER	
DP0	DP1	DP0	DP1
0	1	0	1

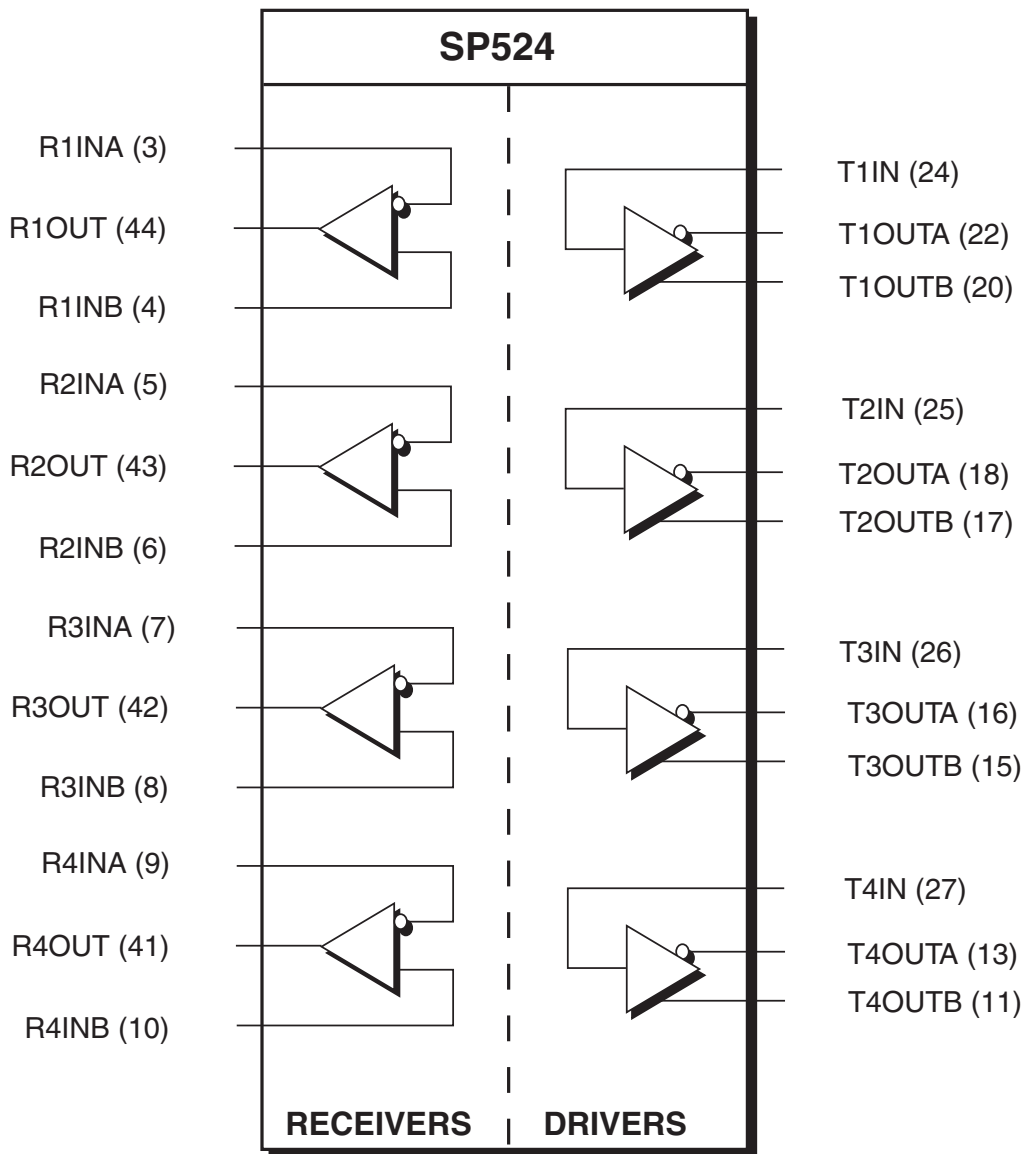

LATCH_EN	$\overline{\text{LOOPBCK}}$	ENT _x	$\overline{\text{ENR}_x}$
1	1	1	0

Figure 13. Mode Diagram — RS422/RS485 for the SP524

APPLICATIONS INFORMATION

DCE-DTE Applications

A serial port can be easily configured for DTE and DCE using multiple **SP522** and/or **SP524** parts. As shown on *Figure 14*, the transceivers are half-duplexed to provide convenient DCE-DTE capability. The driver outputs are connected to the receiver inputs with only one pair out to the serial port for each driver/receiver. When the driver is tri-stated by applying a logic low ("0") to ENT, the receivers can be active to receive the appropriate input. The driver output during tri-state is high impedance, therefore will not degrade the signal levels of the receiver input signal. When the receiver is tri-stated by applying a logic ("1") to $\overline{\text{ENR}}$, the driver output is active to drive the appropriate signal without interference from the receiver. The receiver inputs are at least 12k Ω to ground during tri-state.

Configuring Additional Multi-Protocol Transceivers

Serial ports usually can have two data signals (SD, RD), three clock signals (TT, ST, RT), and at least eight control signals (CS, RS, etc.). EIA-RS-449 contains twenty six signal types including for a DB-37 connector. A DB-37 serial port design may require thirteen drivers and fourteen receivers. Although many applications do not use all these signals, some applications may need to support extra functions such as diagnostics. Sipex's SP504 supports enough transceivers for the primary channels of data, clock and control signals. Configuring LL, RL and TM may require two additional drivers and one receiver if designing for a DTE (one driver and two receivers for a DCE).

The **SP522** and **SP524** is a convenient solution in a design that requires two extra single ended or differential transceivers. The SP504 and **SP522**, shown in *Figure 15*, can be programmed in various configurations. The SP504 is programmed for RS-449 mode. By connecting the decoder pins of the SP504 to the DP0 and DP1 pins accordingly, the SP522 is programmed in RS-423 mode. This adds two single ended transceivers to the application. For applications needing more than five RS-422 transceivers or more than three RS-423 transceivers, the SP504

can be programmed to RS-422 whereas a SP524 can be added and programmed to RS-423, thus creating seven RS-422 channels and four RS-423 channels. The SP504 and the **SP522/SP524** can be configured to custom fit the various serial port application needs.

+5V Only Operation Using the SP782

The **SP522** and **SP524** use external $\pm 10\text{V}$ or $\pm 5\text{V}$ voltage supplies for power to maintain the RS-232 and RS-423 voltage levels, respectively. However, if a low-cost +5V solution is preferred, the **SP522** and **SP524** can be configured with the SP782 or SP784 programmable charge pump. The Sipex patent-pending programmable charge pumps offer $\pm 10\text{V}$ or $\pm 5\text{V}$ outputs. The programmability is used for switching from RS-232 using the $\pm 10\text{V}$ outputs to RS-423 using the $\pm 5\text{V}$ outputs. The SP782 requires 0.1 μF capacitors and the SP784 requires 10 μF capacitors for the charge pump. Please refer to the SP782 and SP784 data sheet for details on the programmable charge pump.

Achieving $\pm 10\text{V}$ with $\pm 12\text{V}$ Supplies

Since the **SP522** and **SP524** use external $\pm 10\text{V}$ supplies, systems that have $\pm 12\text{V}$ supplies must be regulated down to $\pm 10\text{V}$. This can be simply configured by placing diodes in series with the V_{DD} and V_{SS} lines. The absolute maximum supply voltage is $\pm 12\text{V}$. Since most $\pm 12\text{V}$ power supplies have some voltage tolerances, usually $\pm 10\%$, any increase above the 12V maximum will damage the device. However, the $\pm 12\text{V}$ supply may be used providing that the maximum supply voltages do not exceed the rated absolute maximum V_{SS} and V_{DD} .

Sequencing of Power Supplies

Power Supplies for the **SP522** and **SP524** must be sequenced. The recommended sequence is V_{CC} first, V_{DD} 50-80 μSec later and V_{SS} 100 to 1,000 μSec after V_{DD} . There are no sequencing requirements for the **SP522** or **SP524** when they are powered from either the **SP782** or **SP784** charge pump devices or from the V_{DD} and V_{SS} supply pins of the **SP504** or **SP505** charge pump powered devices. For further details, see the application note, V_{DD} , V_{CC} and V_{SS} Power Supply Sequencing.

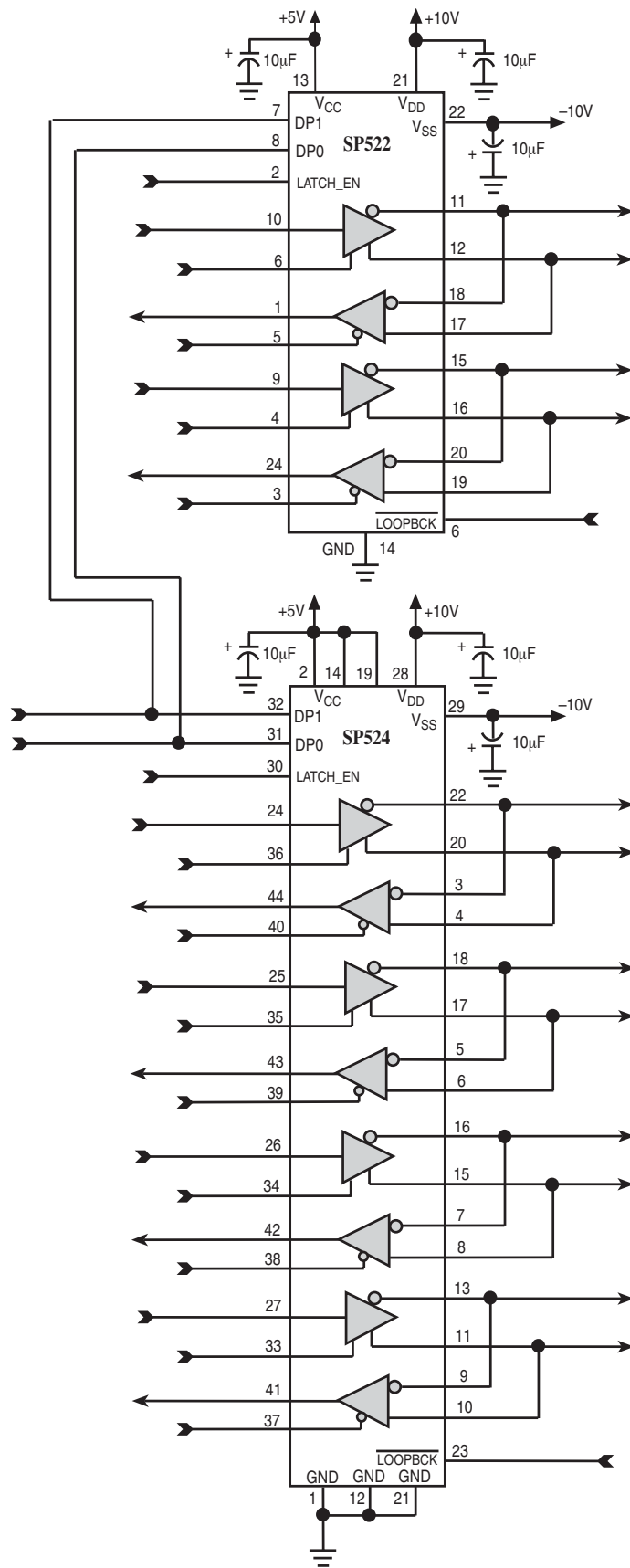
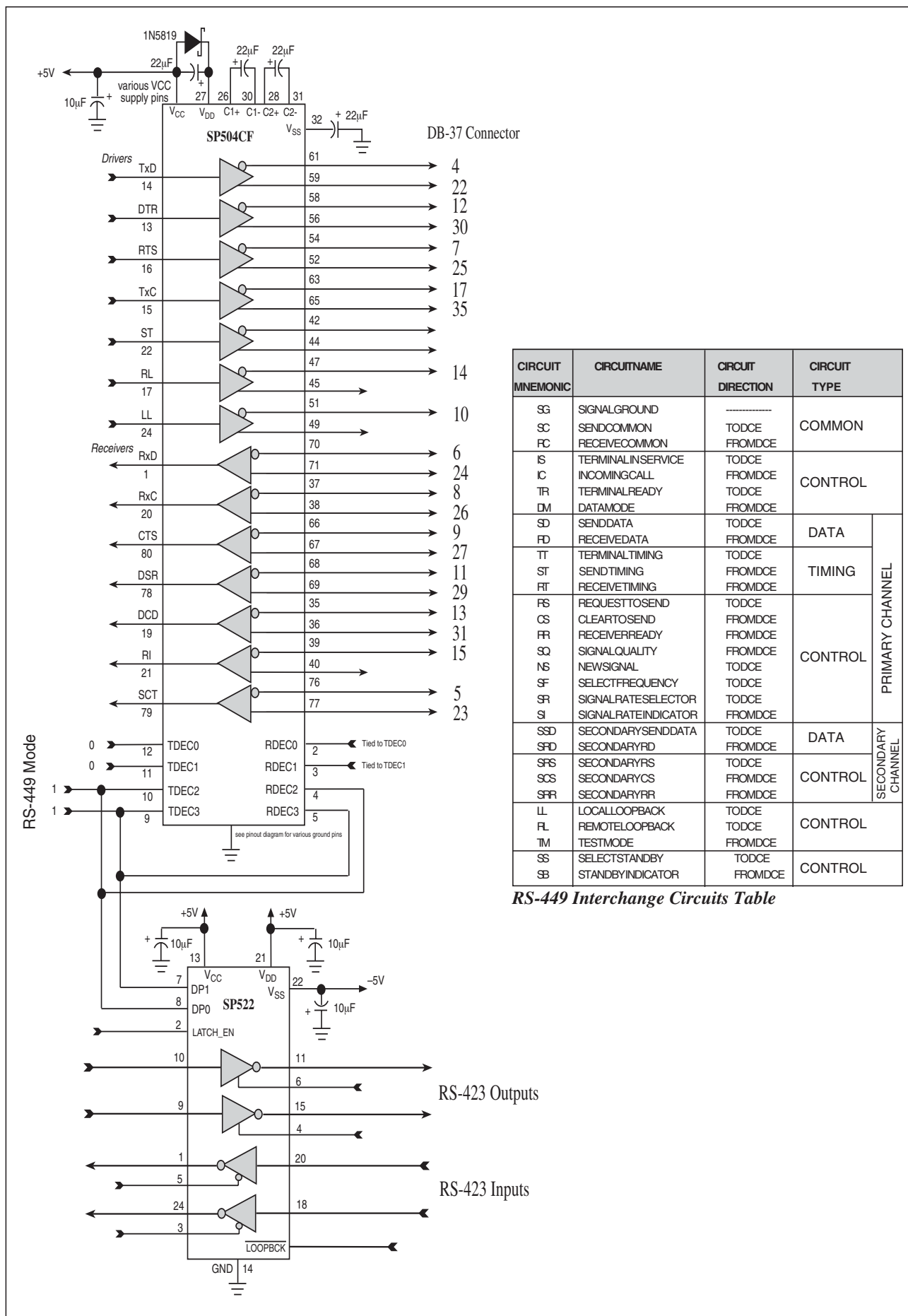

Figure 14. DTE/DCE Application with the SP522 and SP524



CIRCUIT MNEMONIC	CIRCUITNAME	CIRCUIT DIRECTION	CIRCUIT TYPE	
SG	SIGNALGROUND	-----	COMMON	
SC	SENDCOMMON	TODCE	COMMON	
FC	RECEIVECOMMON	FROMDCE	COMMON	
IS	TERMINALINSERVICE	TODCE	CONTROL	
IC	INCOMINGCALL	FROMDCE	CONTROL	
TR	TERMINALREADY	TODCE	CONTROL	
DM	DATAMODE	FROMDCE	CONTROL	
SD	SENDATA	TODCE	DATA	PRIMARY CHANNEL
FD	RECEIVEDATA	FROMDCE	DATA	
TT	TERMINALTIMING	TODCE	TIMING	PRIMARY CHANNEL
ST	SENDTIMING	FROMDCE	TIMING	
RT	RECEIVETIMING	FROMDCE	TIMING	
RS	REQUESTTOSEND	TODCE	CONTROL	PRIMARY CHANNEL
CS	CLEARTOSEND	FROMDCE	CONTROL	
FR	RECEIVERREADY	FROMDCE	CONTROL	
SQ	SIGNALQUALITY	FROMDCE	CONTROL	
NS	NEWSIGNAL	TODCE	CONTROL	
SF	SELECTFREQUENCY	TODCE	CONTROL	
SR	SIGNALRATESELECTOR	TODCE	CONTROL	
SI	SIGNALRATEINDICATOR	FROMDCE	CONTROL	
SSD	SECONDARYSENDATA	TODCE	DATA	SECONDARY CHANNEL
SFD	SECONDARYRD	FROMDCE	DATA	
SRS	SECONDARYRS	TODCE	CONTROL	SECONDARY CHANNEL
SCS	SECONDARYCS	FROMDCE	CONTROL	
SFR	SECONDARYFR	FROMDCE	CONTROL	
LL	LOCALLOOPBACK	TODCE	CONTROL	SECONDARY CHANNEL
FL	REMOOTELOOPBACK	TODCE	CONTROL	
TM	TESTMODE	FROMDCE	CONTROL	
SS	SELECTSTANDBY	TODCE	CONTROL	
SB	STANDBYINDICATOR	FROMDCE	CONTROL	

RS-449 Interchange Circuits Table

Figure 15. Adding extra channels using the SP522 and SP504

**PACKAGE: PLASTIC
SMALL OUTLINE (SOIC)
(WIDE)**

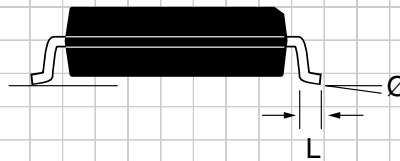
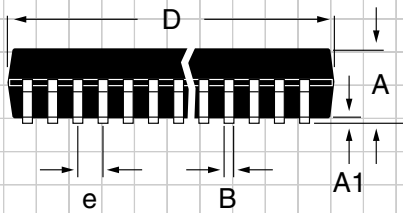
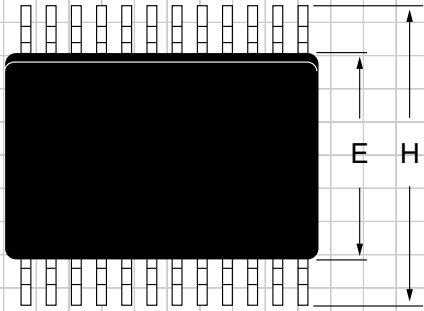

DIMENSIONS (Inches) Minimum/Maximum (mm)	24-PIN					
A	0.093/0.104 (2.352/2.649)					
A1	0.004/0.012 (0.102/0.300)					
B	0.013/0.020 (0.330/0.508)					
D	0.599/0.614 (15.20/15.59)					
E	0.291/0.299 (7.402/7.600)					
e	0.050 BSC (1.270 BSC)					
H	0.394/0.419 (10.00/10.64)					
L	0.016/0.050 (0.406/1.270)					
Ø	0°/8° (0°/8°)					

**PACKAGE: PLASTIC SHRINK
SMALL OUTLINE
(SSOP)**

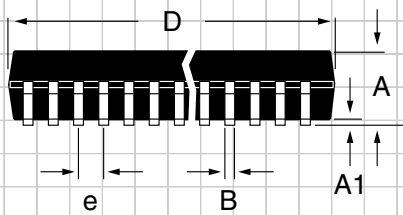
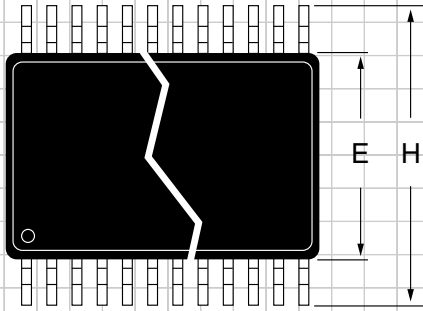

DIMENSIONS (Inches) Minimum/Maximum (mm)	24-PIN					
A	0.068/0.078 (1.73/1.99)					
A1	0.002/0.008 (0.05/0.21)					
B	0.010/0.015 (0.25/0.38)					
D	0.317/0.328 (8.07/8.33)					
E	0.205/0.212 (5.20/5.38)					
e	0.0256 BSC (0.65 BSC)					
H	0.301/0.311 (7.65/7.90)					
L	0.022/0.037 (0.55/0.95)					
Ø	0°/8° (0°/8°)					

PACKAGE: 44 Pin MQFP

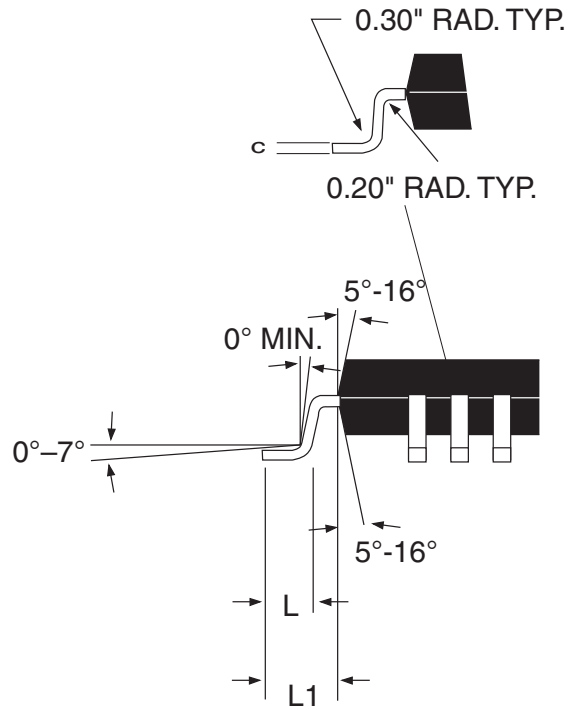
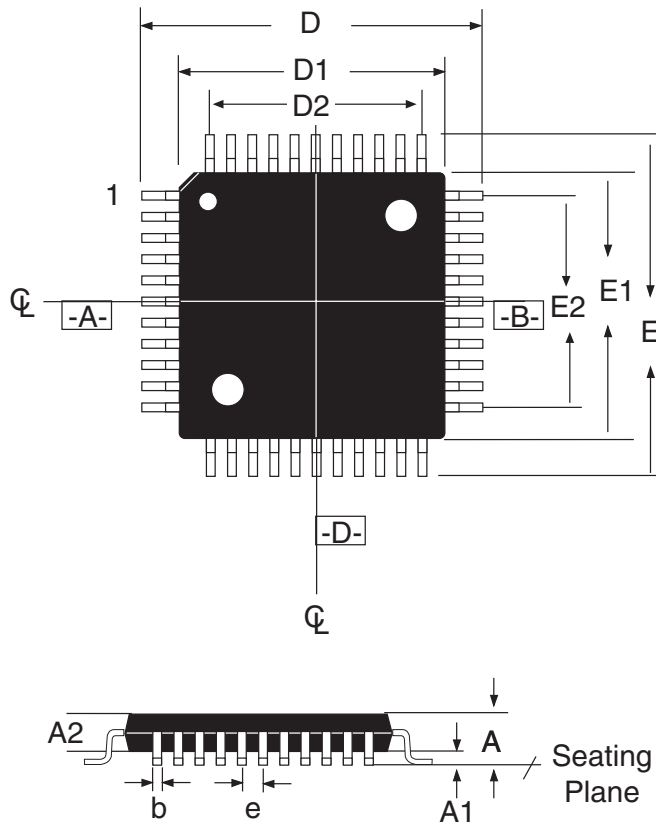

DIMENSIONS Minimum/Maximum (mm)	44-PIN MQFP JEDEC MS-022 (AB) Variation		
	MIN	NOM	MAX
SYMBOL			
A			2.45
A1	0.00		0.25
A2	1.80	2.00	2.20
b	0.29		0.45
D	13.20 BSC		
D1	10.00 BSC		
D2	8.00 REF		
E	13.20 BSC		
E1	10.00 BSC		
E2	8.00 REF		
e	0.80 BSC		
N	44		

COMMON DIMENSIONS			
SYMBOL	MIN	NOM	MAX
c	0.11		23.00
L	0.73	0.88	1.03
L1	1.60 BASIC		

44 PIN MQFP (MS-022 BC)

PACKAGE: 44 Pin LQFP

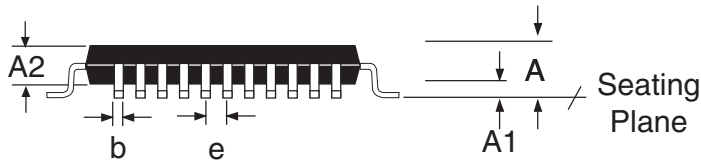
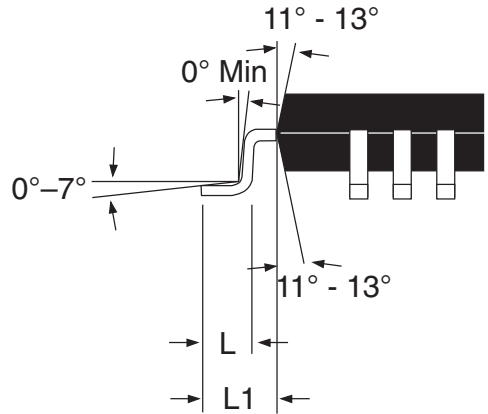
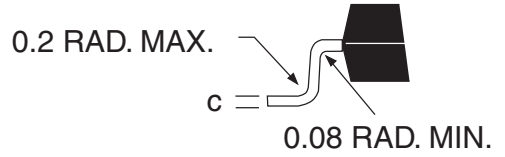
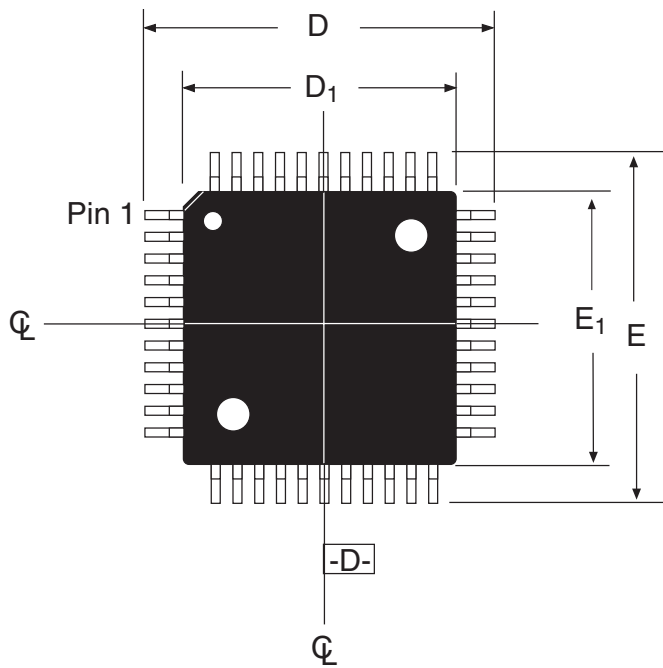

DIMENSIONS Minimum/Maximum (mm)	44-PIN LQFP JEDEC MS-026 (BCB) Variation		
	MIN	NOM	MAX
SYMBOL			
A			1.60
A₁	0.05		0.15
A₂	1.35	1.40	1.45
b	0.30	0.37	0.50
D	12.00 BSC		
D₁	10.00 BSC		
e	0.80 BSC		
E	12.00 BSC		
E₁	10.00 BSC		
N	44		

COMMON DIMENSIONS			
SYMBL	MIN	NOM	MAX
c	0.11		23.00
L	0.45	0.60	0.75
L₁	1.00 BASIC		

44 PIN LQFP

ORDERING INFORMATION

Model	Temperature Range	Package Types
SP522CT	0°C to +70°C	24-pin SOIC
SP522CA	0°C to +70°C	24-pin SSOP
SP524CF	0°C to +70°C	44-pin MQFP
SP524CM	0°C to +70°C	44-pin LQFP

Please consult the factory for pricing and availability on a Tape-On-Reel option.

The SP522 is obsolete. Suggested upgrade is SP322.

The SP524 is not recommended for new designs. Suggested upgrade is SP526.



ANALOG EXCELLENCE

Sipex Corporation

Headquarters and Sales Office

233 South Hillview Drive
Milpitas, CA 95035
TEL: (408) 934-7500
FAX: (408) 935-7600

Sales Office

22 Linnell Circle
Billerica, MA 01821
TEL: (978) 667-8700
FAX: (978) 670-9001
e-mail: sales@sipex.com

Sipex Corporation reserves the right to make changes to any products described herein. Sipex does not assume any liability arising out of the application or use of any product or circuit described hereing; neither does it convey any license under its patent rights nor the rights of others.