



STANDARD
MICROSYSTEMS
CORPORATION

LAN83C180
PRELIMINARY

10/100 Fast Ethernet PHY Transceiver

FEATURES

- Single Chip 100Base-TX/10Base-T Ethernet Physical Layer (PHY) Solution
- Dual Speed – 10/100 Mbps
- Full MII Interface for a Glueless MAC Connection
- MI Interface for Configuration and Status
- Half Duplex and Full Duplex in Both 10BASE-T and 100BASE-TX
- Repeater Mode
- Extended Register Set
- Integrated 10BASE-T Transceivers and Receive/Transmit Filters
- Integrated Adaptive Equalizer and Base Line Wander Correction
- Full Auto Negotiation Support for 10BASE-T and 100BASE-TX Both Half and Full Duplex
- Parallel Detection for Supporting Non Auto Negotiation Legacy in Link Partners
- Low Current
- Low Power Mode
- Internal Power on Reset
- Single Magnetics for 10BASE-T and 100BASE-TX Operation for a Single RJ45 Connector
- Support for IEEE-802.3x Flow Control Specification
- 5 Integrated Status LED Drivers
 - Full Duplex
 - 10/100
 - Activity
 - Collision
 - Link
- Low External Component Count
- 64 Pin TQFP Package (1.0 mm Body Thickness)

GENERAL DESCRIPTION

The LAN83C180 is a single chip CMOS physical layer (PHY) solution providing all necessary functions between the Media Independent Interface (MII) and the magnetics connected to Category 5 twisted pair media. It is designed for 10BASE-T and 100BASE-TX Ethernet, and is based on the IEEE 802.3 specifications.

The LAN83C180 is compatible with the Auto Negotiation section of IEEE 802.3u and provides all the support needed for the IEEE 802.3x Full Duplex specification. The LAN83C180 can operate in adapter mode or repeater/switch modes.

ORDERING INFORMATION

Order Number: LAN83C180 TQFP
64 Pin TQFP Package

© 2000 STANDARD MICROSYSTEMS CORPORATION (SMSC)



80 Arkay Drive
Hauppauge, NY 11788
(631) 435-6000
FAX (631) 273-3123

Standard Microsystems is a registered trademark of Standard Microsystems Corporation, and SMSC is a trademark of Standard Microsystems Corporation. Product names and company names are the trademarks of their respective holders. Circuit diagrams utilizing SMSC products are included as a means of illustrating typical applications; consequently complete information sufficient for construction purposes is not necessarily given. Although the information has been checked and is believed to be accurate, no responsibility is assumed for inaccuracies. SMSC reserves the right to make changes to specifications and product descriptions at any time without notice. Contact your local SMSC sales office to obtain the latest specifications before placing your product order. The provision of this information does not convey to the purchaser of the semiconductor devices described any licenses under the patent rights of SMSC or others. All sales are expressly conditional on your agreement to the terms and conditions of the most recently dated version of SMSC's standard Terms of Sale Agreement dated before the date of your order (the "Terms of Sale Agreement"). The product may contain design defects or errors known as anomalies which may cause the product's functions to deviate from published specifications. Anomaly sheets are available upon request. SMSC products are not designed, intended, authorized or warranted for use in any life support or other application where product failure could cause or contribute to personal injury or severe property damage. Any and all such uses without prior written approval of an Officer of SMSC and further testing and/or modification will be fully at the risk of the customer. Copies of this document or other SMSC literature, as well as the Terms of Sale Agreement, may be obtained by visiting SMSC's website at <http://www.smisc.com>.

SMSC DISCLAIMS AND EXCLUDES ANY AND ALL WARRANTIES, INCLUDING WITHOUT LIMITATION ANY AND ALL IMPLIED WARRANTIES OF MERCHANTABILITY, FITNESS FOR A PARTICULAR PURPOSE, TITLE, AND AGAINST INFRINGEMENT, AND ANY AND ALL WARRANTIES ARISING FROM ANY COURSE OF DEALING OR USAGE OF TRADE.

IN NO EVENT SHALL SMSC BE LIABLE FOR ANY DIRECT, INCIDENTAL, INDIRECT, SPECIAL, PUNITIVE, OR CONSEQUENTIAL DAMAGES; OR FOR LOST DATA, PROFITS, SAVINGS OR REVENUES OF ANY KIND; REGARDLESS OF THE FORM OF ACTION, WHETHER BASED ON CONTRACT; TORT; NEGLIGENCE OF SMSC OR OTHERS; STRICT LIABILITY; BREACH OF WARRANTY; OR OTHERWISE; WHETHER OR NOT ANY REMEDY IS HELD TO HAVE FAILED OF ITS ESSENTIAL PURPOSE, AND WHETHER OR NOT SMSC HAS BEEN ADVISED OF THE POSSIBILITY OF SUCH DAMAGES.

TABLE OF CONTENTS

FEATURES	1
GENERAL DESCRIPTION	1
PIN CONFIGURATION	4
DESCRIPTION OF PIN FUNCTIONS	5
FUNCTIONAL DESCRIPTION	7
25MHz Reference Clock	7
10BASE-T OPERATION	7
10Mb/s Data Transfer on the MII	7
RX10 Clock Recovery.....	7
100MHz Synthesizer.....	7
TX10 Pulse Shaper & Filter	7
TX10 Latency.....	7
RX10 Filter & RX10 Signal Detect	7
RX10 Latency	8
100BASE-TX OPERATION	8
100Mb/s Data Exchange on the MII Interface.....	8
125MHz Synthesizer.....	8
TX100 PISO, Encoder and Scrambler.....	8
TX100 Driver.....	8
TX100 Latency.....	8
RX100 Equalizer & Base-line Wander Correction	8
RX100 Clock Recovery.....	8
RX100 SIPO, Decoder and Descrambler	9
RX100 Latency	9
100Mb/s Transmit Errors	9
100Mb/s Receive Errors	9
CONTROLS	10
Initialization (nRESET).....	10
Reset Mode	10
Low-Power Mode	10
Loopback Mode	10
Repeater Mode	10
ICFG - Interrupt.....	11
Auto-Negotiation Enable (ANEN).....	11
MII Management Interface.....	11
MANAGEMENT	13
MAC Access to PHY Management Registers	13
RESISTER SET	13
OPERATING CONDITIONS	18
MAXIMUM GUARANTEED RATINGS*	18
DC ELECTRICAL CHARACTERISTICS	18
DIFFERENTIAL OUTPUT.....	18
AC ELECTRICAL CHARACTERISTICS	19
REFCLK.....	19
RX_CLK	19
TX_CLK	19
MDC.....	19
EXTERNAL COMPONENTS	20
Connecting an External 25MHz Reference.....	20
nRESET Pull-up Resistor.....	20
RX Input Decoupling.....	20
Crystal Oscillator.....	20
PACKAGE DETAILS	21
LAN83C180 REVISIONS	22

PIN CONFIGURATION

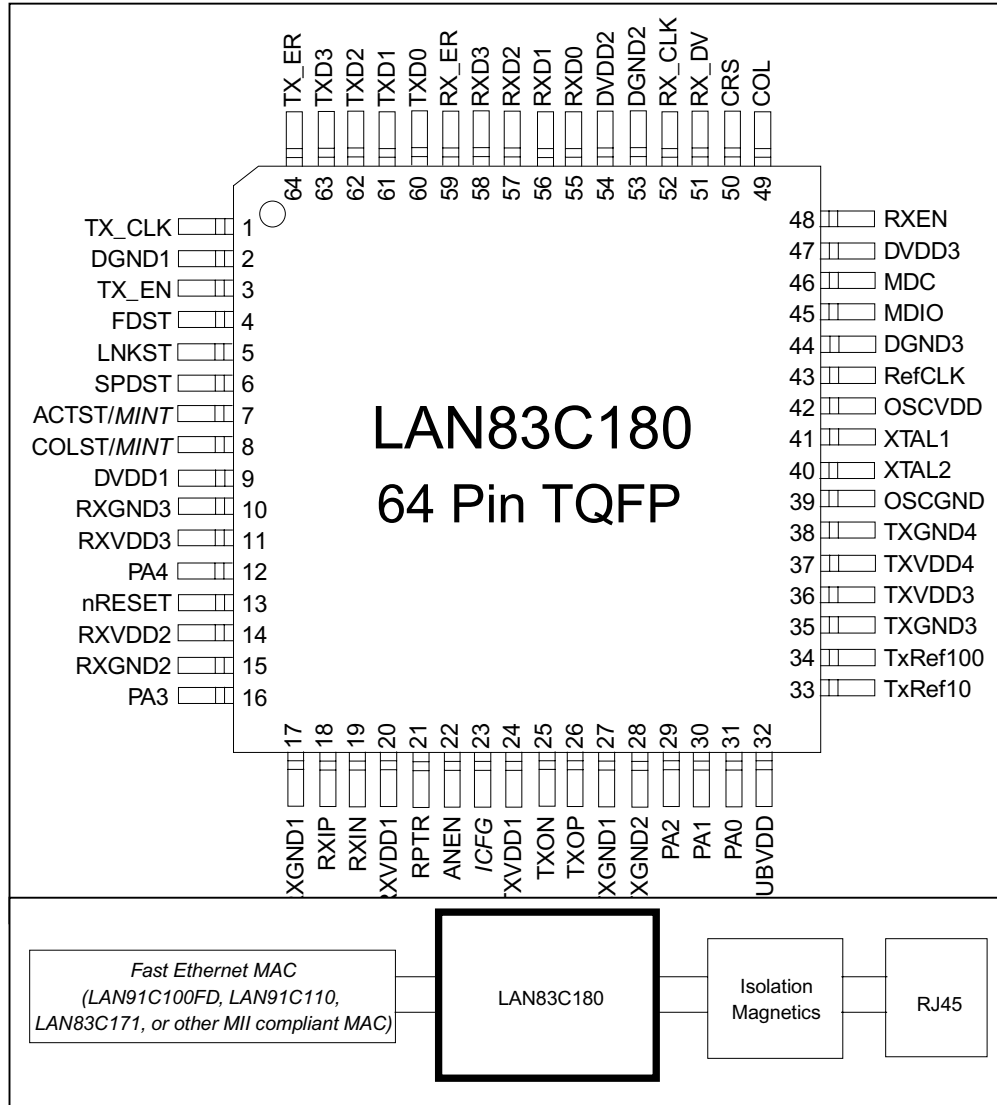

FIGURE 1 – SYSTEM BLOCK DIAGRAM

DESCRIPTION OF PIN FUNCTIONS

PIN #	NAME	TYPE	DESCRIPTION
MD INTERFACE			
19	RXIN	Diff. Input	Differential receive pair from magnetics (-)
18	RXIP	Diff. Input	Differential receive pair from magnetics (+)
25	TXON	Diff. Output	100 Differential transmit pair to magnetics (-)
26	TXOP	Diff. Output	100 Differential transmit pair to magnetics (+)
33	TXREF10	Input	10BASE-T transmitter current setting pin
34	TXREF100	Input	100BASE-TX transmitter current setting pin
13	nRESET	Input/ Output	Active low, power-on reset output and external reset input.
41	XTAL1	Input	25MHz crystal input. <i>This signal should be pulled high when using REFCLK.</i>
40	XTAL2	Input	25MHz crystal input. <i>This signal should be left unconnected when using REFCLK.</i>
MII INTERFACE			
46	MDC	Input	Management interface clock (up to 2.5MHz)
45	MDIO	Input/ OUTPUT	Management data
52	RX_CLK	Output	Receive clock (2.5MHz for 10, 25MHz for 100)
55,56,57,58	RXD0,RXD1,RXD2, RXD3	Output	Receive data MII interface
51	RX_DV	Output	Receive data valid. Active high
59	RX_ER	Output	Receive error. Active high. (RXD4 in symbol mode)
1	TX_CLK	Output	Transmit clock (2.5MHz for 10, 25MHz for 100)
60,61,62,63	TXD0,TXD1,TXD2,T XD3	Input	Transmit Data MII interface
3	TX_EN	Input	Transmit Enable. Active high
64	TX_ER	Input	Transmit Error. Active high. (TXD4 in symbol mode)
50	CRS	Output	Carrier sense signal. Active high
49	COL	Output	Collision signal. Active high
MISCELLANEOUS			
43	REFCLK	Input	Reference clock. <i>This signal should be pulled high when using crystal.</i>
22	ANEN	Input	Auto Negotiation enable. Active high
48	RXEN	Input	Receive enable. Active high
21	RPTR	Input	Repeater enable. Active high
31,30,29,16,12	PA0,PA1, PA2,PA3,PA4	Input	PHY address
MISCELLANEOUS/LED			
4	FDST	Input/ OUTPUT	Full duplex LED status indication when nRESET high. Active low. Input when nRESET is low. High input means the LAN83C180 advertises full duplex capability
6	SPDST	Input	Speed (10/100) LED status indication when nRESET high. High for 100Mb/s mode. Input when nRESET is low. Low input will cause the LAN83C180 to advertise 100Mb/s capability.
23	ICFG	Input	Interrupt configuration. <i>MINT on pin 8 when High, on pin 7 when Low.</i>
7	ACTST/MINT	Output	Receive/Transmit activity LED status indication (Active Low) if ICFG = 1. If ICFG = 0, output is MINT and activity is indicated on the LNKST output.

PIN #	NAME	TYPE	DESCRIPTION
8	COLST/MINT	Output	<i>Collision LED status indication (Active Low) if ICFG = 0. If ICFG = 1, output is MINT and collision indication is lost.</i>
5	LNKST	Output	<i>Link LED status indication (Active Low). If ICFG = 0, LNKST flashes to indicate activity.</i>
7 or 8	MINT	Output	<i>Link status change interrupt. Default active low. Set register 24, bit 12 = 1 for active high interrupt.</i>
POWER			
9, 47, 54	DVDD1, DVDD3, DVDD2	Power	Digital +5V supply
11, 14, 20, 24, 36, 37	RXVDD3, RXVDD2, RXVDD1, TXVDD1, TXVDD3, TXVDD4	Power	Analog +5V supply
2, 44, 53	DGND1, DGND3, DGND2	Power	Digital ground
10, 15, 17, 27, 28, 35, 38, 39	RXGND3, RXGND2, RXGND1, TXGND1, TXGND2, TXGND3, TXGND4, OSCGND	Power	Analog ground
32	SUBVDD	Power / Ref.	Voltage Reference. Connect to very clean +5V power supply. The pin is used for voltage reference only. See application note for details.
42	OSCVDD	Power	Oscillator Power. Connect to +5V power supply.

FUNCTIONAL DESCRIPTION

The LAN83C180 has three basic operating modes: 10BASE-T mode, 100BASE-TX mode and LOW-POWER mode. The modes are selected by bits 11 and 13 respectively in register 0. The Control block is designed to manage these modes by starting and stopping the two transceivers in a well-controlled manner such that no spurious signals are output on either the MII or twisted-pair interfaces. Furthermore, it continuously monitors the behavior of the transceivers and takes corrective action if a fault is detected.

Other modes described herein are repeater mode and reset mode.

25MHz Reference Clock

The LAN83C180 requires a 25MHz +/-100ppm timing reference for 802.3 compatible operation. This may be supplied either from the integrated oscillator or from an external source. When the integrated oscillator is used, a suitable crystal must be connected across the XTAL1 & XTAL2 pins (see "External Components"). When an external source is used, it must be input to the REFCLK pin and XTAL1 must be tied high. XTAL2 must be unconnected.

10BASE-T OPERATION

10Mb/s Data Transfer on the MII

10Mb/s data is transferred across the MII with clock speeds of 2.5MHz. The MAC outputs data to the LAN83C180 via the MII interface, on the TXD[3:0] bus. This data is synchronized to the rising edge of TX_CLK. To indicate that there is valid data for transmission on the MII, the MAC sets the TX_EN signal active. This forces the LAN83C180 device to take in the data on the TXD[3:0] bus. This is serialized and directly encoded as Manchester data, before being output on the TXOP/TXON differential output for transmission through 1:1 magnetics and onto the twisted-pair. The Pulse Shaper & Filter employs a digital finite impulse response filter (FIR) to pre-compensate for line distortion and to remove high frequency components in accordance with the 802.3 Standard. The transmit current is governed by the current through the TXREF10 pin, which must be grounded through a resistor as described in "External Components".

If TX_ER is active while TX_EN is high, then the LAN83C180 will transmit the illegal codes JKJK (00 11 00 11) on the serial data out. This ensures that errors are propagated to the link partner.

RX10 Clock Recovery

The LAN83C180 employs a digital delay line controlled by the 100MHz Synthesizer DLL to derive a sampling clock from the incoming signal. The recovered clock runs at twice the data rate (nominally 20MHz). When a signal is received from the Signal Detect block, it is used to strobe Link Pulses and Manchester encoded serial data.

The Manchester data stream will be decoded into a 4-bit parallel data bus, RXD[3:0]. The RXD bus is clocked out on RX_CLK rising. The LAN83C180 must detect the first 4 bits of preamble before RX_DV is set high. When RX_DV is high, any Manchester coding violation will set RX_ER high. RX_DV is reset by a continuous sequence of zeroes, or by the end-of-packet IDLE terminator (11 11 00 00). While RX_DV is low, the data on the receive nibble is always 5h.

100MHz Synthesizer

This synthesizer employs a delay-locked loop (DLL) to generate a 100MHz timing reference from the 25MHz reference clock. This 100MHz reference is used by the 10BASE-T transmit and receive functions and is divided by 5 to provide a 20MHz data strobe. The 20MHz clock is used to derive the 2.5 MHz TX_CLK in 10BASE-T mode. The synthesizer is disabled when not in 10BASE-T mode.

TX10 Pulse Shaper & Filter

The Pulse Shaper & Filter employs a digital finite impulse response filter (FIR) to pre-compensate for line distortion and to remove high frequency components in accordance with the 802.3 Standard. The Pulse Shaper & Filter is disabled when not in 10BASE-T mode.

TX10 Latency

When connected to appropriate magnetics the latency through the TX10 path is less than 2BT (200ns) for data transmissions. This timing is measured from the falling edge of TX_CLK to the output of the transmit magnetics. The TX10 path will not transmit the first two Manchester encoded bits of a data transmission, as permitted by the 802.3 Standard.

RX10 Filter & RX10 Signal Detect

These blocks work in unison to remove noise and to block signals that do not achieve the voltage levels specified in 802.3. Signals that do not achieve the required level are not sampled in the Clock Recovery block and are not passed to the outputs.

RX10 Latency

When connected to appropriate magnetics the latency through the RX10 path is less than 6BT (600ns). This timing is measured from the input of the receive magnetics to the falling edge of RX_CLK. The RX10 path may ignore up to three Manchester encoded bits at the start of data reception (802.3 allows up to 5 bits).

100BASE-TX OPERATION

100Mb/s Data Exchange on the MII Interface

100Mb/s data is transferred across the MII with clock speeds of 25MHz. The MAC outputs data to the LAN83C180 via the MII interface, on the TXD[3:0] bus. This data is synchronized to the rising edge of TX_CLK. To indicate that there is valid data for transmission on the MII, the MAC sets the TX_EN signal active. This forces the LAN83C180 device to take in the data on the TXD[3:0] bus and replace the first octet of the MAC preamble with Start-of-Stream Delimiter (SSD) symbols to indicate the start of the Physical Layer Stream.

When the data transfer across the MII is complete, the MAC deasserts the TX_EN signal and the LAN83C180 adds End-of-Stream Delimiters (ESD) symbols onto the end of the data stream. The complete data stream (the Physical Layer Stream) is encoded from 4 bits into 5 bits, scrambled, converted to MLT3 and driven to the TXOP and TXON pin differentially.

The TX100 path is disabled when not in 100BASE-TX mode and, with the exception of the RX100 Signal Detect, the RX100 Receive Path is disabled when not in 100BASE-TX mode.

125MHz Synthesizer

This synthesizer employs a phase-locked loop (PLL) to generate a 125MHz timing reference from the 25MHz reference clock. This 125MHz reference is used by the 100BASE-TX transmit function and is divided by 5 to provide a 25MHz data strobe on TX_CLK. TX_CLK is frequency and phase locked to the 25MHz reference with a small phase offset. The synthesizer is disabled when not in 100BASE-TX mode.

TX100 PISO, Encoder and Scrambler

The TX100 PISO, Encoder and scrambler loads data from the MII on the rising edge of TX_CLK, and converts them to serial MLT3 for outputting to the TX100 Driver. The TXD[3] bit is output first. The PISO & Encoder do not operate until the 125MHz Synthesizer is locked to the 25MHz reference. This avoids transmission of spurious signals onto the twisted-pair.

TX100 Driver

The TX100 Driver outputs the differential signal onto the TXOP and TXON pins. It operates with 1:1 magnetics to provide impedance matching and amplification of the signal in accordance with the 802.3 specifications. The transmit current is governed by the current through the TXREF100 pin, which must be grounded through a resistor as described in "External Components". The TX100 driver is disabled in 10BASE-T mode and in loop back mode. If no data is being transmitted from the MAC, the LAN83C180 outputs idle symbols of 11111 (suitably scrambled).

TX100 Latency

The transmit latency from the first TX_CLK rising when TX_EN is high to the first bit of the "J" symbol on the cable is 8BT.

RX100 Equalizer & Base-line Wander Correction

The RX100 Equalizer compensates for the signal attenuation and distortion resulting from transmission down the cable and through the isolation transformers. The Equalizer is self-adjusting and is designed to restore signals received from up to 10dB cable attenuation (at 16MHz). When the Equalizer is active it adjusts to the incoming signal within 1ms. Thereafter, the Equalizer will continuously adjust to small variations in signal level without corrupting the received data.

The 100BASE-TX MLT3 code contains significant low frequency components which are not passed through the isolation transformers and cannot be restored by an adaptive equalizer. This leads to a phenomenon known as base-line wander which will cause an unacceptable increase in error rate, if not corrected. The LAN83C180 employs a quantized feedback technique to restore the low frequency components and thus maintain a very low error rate even when receiving signals such as the "killer packet" described in the TP_PMD spec.

RX100 Clock Recovery

The RX100 Clock Recovery circuit uses a Phase-Locked Loop (PLL) to derive a sampling clock from the incoming signal. The recovered clock runs at the symbol bit rate (nominally 125MHz) and is used to clock the MLT3 decoder and the Serial to Parallel converter (SIPO). The recovered clock is divided by 5 to generate the receive clock (RX_CLK) which is used to strobe received data across the MII interface. When no signal is detected in 100BASE-TX mode, the PLL is locked to the reference clock and runs at 125MHz. This ensures that RX_CLK runs continuously at 25MHz in 100BASE-TX mode. When a signal is present, the Clock Recovery PLL remains locked to

the reference until the equalizer has adjusted, then it requires up to 1ms to phase lock to the incoming signal. No data is passed to the MII interface until lock is established.

RX100 SIPO, Decoder and Descrambler

The RX100 SIPO, Decoder and descrambler convert the received signal from serial MLT3 to 4-bit wide parallel receive data on the MII. This appears on the RXD[3:0] bus which is clocked out on the rising edge of RX_CLK. When a frame starts the LAN83C180 decodes the SSD symbols and then asserts the RX_DV signal, in order to inform the MAC that valid data is available. When the LAN83C180 detects the ESD, it deasserts the RX_DV signal.

RX100 Latency

The latency from the first bit of the “J” symbol on the cable to CRS assertion is between 11 and 15BT. The latency from the first bit of the “T” symbol on the cable to CRS de-assertion is between 19 and 23BT.

100Mb/s Transmit Errors

If the LAN83C180 detects that the TX_ER signal has gone active while the TX_EN signal is active, then it will propagate the detected error onto the cable by transmitting the symbol “00100”. Table 1 shows the meaning of the different states of TX_EN and TX_ER. TX_ER is sampled inside the LAN83C180 on the rising edge of TX_CLK.

Table 1 - 100MB/S Transmit Error States

TX_EN	TX_ER	TXD [3:0]	INDICATION
0	X	Ignored	Normal Inter Frame Data
1	0	0000 Through 1111	Normal Data Transmission
1	1	0000 Through 1111	Transmit Error Propagation

100Mb/s Receive Errors

When there is no data on the cable, the receiver will see only the idle code of scrambled 1's. If a non idle symbol is detected, the receiver looks for the SSD so that it can align the incoming message for decoding. If any 2 non consecutive zeros are detected within 10 bits, but are not the SSD symbols a false carrier indication is signaled to the MII by asserting RX_ER and setting RXD[3:0] to 1110 while keeping RX_DV inactive. The remainder of the message is ignored until 10 bits of 1's are detected.

If any data is decoded after a SSD which is neither a valid data code nor an ESD, then an error is flagged by setting RX_ER active while the RX_DV signal is active. This also happens if 2 idle codes are detected before a valid ESD has been received –or- descramble synchronization is lost during packet reception. The states of RX_DV and RX_ER are summarized in Table 2. RX_ER is clocked on the falling edge of RX_CLK, and will remain active for at least 1 period of RX_CLK.

Table 2 - 100MB/S Receive Error States

RX_DV	RX_ER	RXD [3:0]	INDICATION
0	0	0000 Through 1111	Normal Inter Frame
0	1	1110	False Carrier Indication
1	0	0000 Through 1111	Normal Data Reception
1	1	0101 or 0110	Data Reception With Errors

CONTROLS

Initialization, mode selection and other options are governed by the control inputs and register as described in the following paragraphs.

Initialization (nRESET)

The LAN83C180 incorporates a power-on-reset circuit for self-initialization on power-up. During initialization the open-drain nRESET pin is driven low and all data outputs are disabled to prevent spurious outputs to the twisted-pair and to the MII interface. nRESET will remain low until either the 10BASE-T or 100BASE-TX transceiver has been correctly initialized. The LAN83C180 will then release nRESET allowing the external pull-up to pull the pin high. Data transmission and reception will not commence until nRESET is high. This allows the user to extend the inactive period by externally holding nRESET low. It will not normally be necessary for the user to reset the LAN83C180 because it is designed to automatically recover from fault conditions.

However, if required, the user may initialize the device by doing a hardware or software reset.

Reset Mode

There are two types of reset in the LAN83C180 - hardware and software. The hardware reset is activated by setting the nRESET pin to logic 0, and holding it low for at least 100ns. This mode causes an over-all reset in the LAN83C180 - both analog and digital circuitry are reset. While nRESET is low, the SPDST and FDST pins are inputs, and are used to determine the speed and duplex capability which will be advertised during auto-negotiate. A low on SPDST advertises 100M capability. A high on FDST advertises full duplex capability. The software reset is activated by setting bit 15 in register 0 high. This bit is a self clear bit and causes a partial reset of the device. Following is a table summarizing the different blocks to be reset and which reset will affect them:

BLOCK	HW RESET	SW RESET
Management Register	Yes	Yes
PCS state machine (RCV, XMT, ANEG)	Yes	Yes
XMT Scrambler	Yes	Yes
RCV Scramble	Yes	Yes
LAN83C180 Control State Machine	Yes	No
LAN83C180 Analog	Yes	No

During both hardware and software resets, the ACTST, COLST and LNKST LED's will turn on for the duration of the reset and stay on for at least 1 mS after the reset event has ended.

Holding nRESET low will not hold the device in a static, low power state. It will initialize the selected transceiver and start the appropriate clocks. If the reset event is at power up, the clocks are stable 1.4msec max (typ.: 800usec) following the nRESET signal assertion and Vcc ramped to a stable 5V. In case of the nRESET assertion at other times, clocks are stable only a few (typ.: ~1usec) microseconds after the nRESET assertion.

Note: For power saving, use the low-power mode.

Low-Power Mode

This function is set via the management interface. Using MDC/MDIO, Bit 11 of register 0 is written high to put the LAN83C180 into Low-Power mode. In this mode the 10BASE-T and 100BASE-TX transceivers are disabled. This mode is intended to conserve power when the network connection is not required and the TXOP/TXON output is undriven. The oscillator continues to run. Both RX_CLK and TX_CLK are stopped, the RXD bus is held low and TXD, TXEN, and TXER are ignored. MDC and MDIO are still active for new commands.

Loopback Mode

Diagnostic loopback may be selected at any time by asserting setting Bit 14 in register 0. In 10BASE-T mode transmission to the TXOP/ TXON output will be stopped and the RX10 Clock Recovery will receive input from the TX10 transmit path rather than from the RXIP/RXIN inputs. In 100BASE-TX mode transmission to the TXOP/TXON output will be stopped and the RX100 Clock Recovery will receive input from the TX100 transmit path.

Repeater Mode

Setting the RPTR pin high puts the LAN83C180 into repeater mode. In this mode the CRS will be active on receive only. In 100Mbps RPTR mode, the LAN83C180 is able to perform a disconnect function from the MII. This function is enabled by bit 24 in register 0. The default of this bit is 1 (enable) for repeater mode. (Note: if RPTR is low, this bit has no effect). The LAN83C180 will disconnect from the MII if it receives two consecutive false CRS events with no good frame in between them or if a false CRS event is longer then 480 +/- 4 bit time. If the LAN83C180 receives a good carrier event (480 +/- 4 bit time) or a good idle event (idle symbols for a period of 25000 to 30000 bit time) it will resume frame transfer to the MII.

A false CRS event happens if, at the beginning of a carrier event, the JK symbols are not received correctly.

When the LAN83C180 is in 100M mode it will count all false CRS events in register 27 bits 7:0. This counter is self cleared upon read. If a disconnect event occurs between the consecutive reads of register 27, bit 15 in the register will set high.

ICFG - Interrupt

The LAN83C183 offers an "MII" interrupt output which can be used to interrupt the host whenever a change in link status occurs - this output is multiplexed onto either the ACTST or COLST pins. When ICFG is high MINT (the MII interrupt) replaces COLST on pin 8. With ICFG low MINT is output on ACTST (pin 7) and activity is now indicated on the LINKST pin 15 as follows:

No Link - LINKST High

Link, no Activity - LINKST Low

Link, Activity - LINKST Toggles (for flashing LED)

MINT is active low by default, but may be inverted by writing bit 12 of register 24.

MINT will be asserted whenever a change in link status occurs (loss of link/gaining link). MINT will remain asserted until the controller acknowledges the interrupt by writing to register 21 (any data pattern will be accepted).

Should one or more link status change occur between the assertion of MINT and an acknowledge then a further interrupt will be deasserted and then reasserted (min deassertion time 100ns, max 150ns).

Only a single interrupt event may be queued at any one time. Multiple status changes between acknowledge events will generate only a single queued interrupt.

Auto-Negotiation Enable (ANEN)

Auto-negotiation may be disabled on reset by setting the ANEN pin to logic zero. During operation, auto-negotiation can be disabled by setting the ANEN pin low or by setting bit 12 of register 0 to zero. If auto-negotiate is disabled, the LAN83C180 will lose the link, and link will be re-established only after the LAN83C180 control state machine has determined the speed.

MII Management Interface

The management interface is a 2 wire serial interface connecting a PHY to a management entity. The management unit controls the PHY and gathers information on the status of the PHY. It does this via the implemented registers.

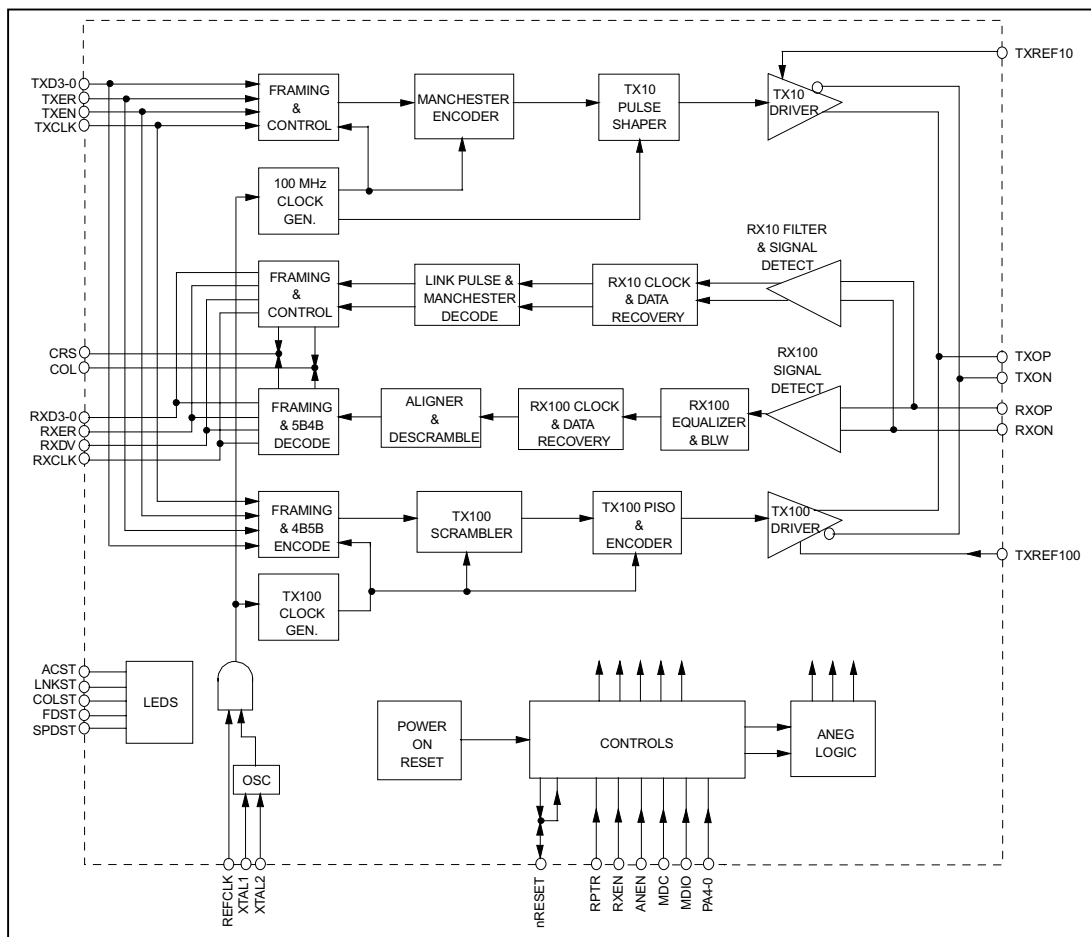

FIGURE 2 – LAN83C180 BLOCK DIAGRAM

MANAGEMENT

MAC Access to PHY Management Registers

The interface to these registers is via the MDC and MDIO signals. The address of the LAN83C180 is specified by the PA<4:0> static inputs. The MD command is issued by the MAC and can be read or write:

COMMAND	PREAMBLE	START DATA	OP CODE	PHY ADDRESS	REG NUMBER	TA	DATA
READ	32 Bits of 1	01b	10b	5 Bits	5 Bits	Z0b	16 bit from PHY
WRITE	32 Bits of 1	01b	01b	5 Bits	5 Bits	10b	16 bit from MAC

RESISTER SET

The following register set is implemented in the LAN83C180 device. Each of the registers is accessible to the MAC at the specified offset. The bit types in the bit description tables follow the following convention:

SC = Self clear

RO = Read only

RW = Read or write

LL = Latch low until register read

LH = Latch high until register read

Res = Reserved

Reg 0 - Control Register

BIT	BIT NAME	DESCRIPTION	DEFAULT	TYPE
15	Reset	1 = PHY reset 0 = Normal operation	0	RW SC
14	Loopback	1 = Loopback mode active 0 = Normal operation	0	RW
13	Speed Selection	1 = 100 Mbps 0 = 10 Mbps	1	RW
12	ANEG Enable	1 = Enable ANEG process 0 = Disable ANEG process	1	RW
11	Power Down	1 = Power down active 0 = Normal operation	0	RW
10	Isolation	1 = Isolation in process 0 = Normal operation	0	RW
9	Restart ANEG	1 = Restart the ANEG process 0 = Normal operation	0	RW SC
8	Duplex Selection	1 = Full Duplex mode 0 = Half duplex mode	1	RW
7	Collision Test	1 = Collision test active 0 = Normal operation	0	RW
6:0	Reserved	Write as 0; ignore on read		

Reg 1 - Status Register

BIT	BIT NAME	DESCRIPTION	DEFAULT	TYPE
15	100BaseT4	1 = PHY able to perform 100BaseT4 0 = PHY not able to perform 100BaseT4	0	RO
14	100Base-TX - FDX	1 = PHY able to perform 100Base-TX 0 = PHY not able to perform 100Base-TX	1	RO
13	100Base-TX - HDX	1 = PHY able to perform 100Base-TX 0 = PHY not able to perform 100Base-TX	1	RO
12	10Base-T - FDX	1 = PHY able to perform 10Base-T 0 = PHY not able to perform 10Base-T	1	RO
11	10BASE-T - HDX	1 = PHY able to perform 10Base-T 0 = PHY not able to perform 10Base-T	1	RO
10	100BASET2 - FDX	1 = PHY able to perform 100BaseT2 0 = PHY not able to perform 100BaseT2	0	RO
9	100BASE-T2 - HDX	1 = PHY able to perform 100BaseT2 0 = PHY not able to perform 100BaseT2	0	RO
8:7	Reserved	Ignore when read	0	RO
6	MF Preamble Supression	1= Phy accept management frames with short preamble 0 = Normal preamble only	0	RO
5	ANEG Complete	1 = ANEG process completed 0 = ANEG process not completed or not active	0	RO
4	Remote Fault	1= Remote fault condition detected 0 = No Remote fault condition detected	0	RO LH
3	ANEG Able	1 = Phy is able to perform ANEG 0 = Phy is not able to perform ANEG	1	RO
2	Link Status	1= Link is up 0 = Link is down	0	RO LL
1	Jabber Detect	1 = Jabber condition detected 0 = Normal operation	0	RO
0	Extended Regs.	1 = Extended register capability 0 = No extended registers	1	RO

Reg 2 - LAN83C180 Identifier Register

BIT	BIT NAME	DESCRIPTION	DEFAULT	TYPE
15:0	OUI	SMSC OUI bits	0282h	RO

Reg 3 - LAN83C180 Identifier Register

BIT	BIT NAME	DESCRIPTION	DEFAULT	TYPE
15:0	OUI/Device ID	SMSC OUI bits and device code	1C52h	RO

Reg 4 - ANEG Advertisement Register

BIT	BIT NAME	DESCRIPTION	DEFAULT	TYPE
15	NP	Next page able - the LAN83C180 is not able to perform next page	0	RO
14	Reserved		0	RO
13	Remote Fault	0 = No remote fault detected 1= A remote fault been detected	0	R/W
12:10	Reserved		0	R/W
9:5	Technology	T4, 100Fdx, 100Hdx, 10Fdx, 10Hdx	0Fh	R/W
4:0	Selector Field		01h	R/W

Reg 5 - ANEG Link Partner Ability Register

BIT	BIT NAME	DESCRIPTION	DEFAULT	TYPE
15	NP	Partner is next page capable	0	RO
14	ACK	Partner sent an acknowledge bit	0	RO
13	Remote Fault	Partner detected a remote fault	0	RO
12:5	Ability	Partner's technology ability	0	RO
4:0	Selector Field	Partner selector field	0	RO

Reg 6 - ANEG Expansion Register

BIT	BIT NAME	DESCRIPTION	DEFAULT	TYPE
15:5	Reserved		0	RO
4	Parallel Detect Fault	1 = A fault has been detected 0 = Aneg process finished. no fault detected	0	RO LH
3	Link Partner Next Page Able	0 = Link partner is not next page able 1 = Link partner is next page able	0	RO
2	Next Page Able	0 = LAN83C180 is not able for next page	0	RO
1	Page Received	0 = No new page been received 1 = A new page has been received and is in reg 5	0	RO LH
0	Link Partner Aneg Able	0 = Link partner is not aneg able 1 = Link partner is aneg able	0	RO

Reg 16 - TX100 Test Reg

BIT	BIT NAME	DESCRIPTION	DEFAULT	TYPE
15:0	Reserved	Test mode only	0000h	Res

Reg 17 - RX100 Test Reg

BIT	BIT NAME	DESCRIPTION	DEFAULT	TYPE
15:0	Reserved	Test mode only	0000h	Res

Reg 18 - TX10 Test Reg

BIT	BIT NAME	DESCRIPTION	DEFAULT	TYPE
15:0	Reserved	Test mode only	0000h	Res

Reg 19 - RX10 Test Reg

BIT	BIT NAME	DESCRIPTION	DEFAULT	TYPE
15:0	Reserved	Test mode only	0000h	Res

Reg 20 - CONTROL Test Reg

BIT	BIT NAME	DESCRIPTION	DEFAULT	TYPE
15:0	Reserved	Test mode only	0000h	Res

Reg 21 – Interrupt Handshake Reg

BIT	BIT NAME	DESCRIPTION	DEFAULT	TYPE
15:0	Clear INT	Clears MINT output	0000h	WO

Reg 24 - LAN83C180 Specific Register

BIT	BIT NAME	DESCRIPTION	DEFAULT	TYPE
15:14	Test Access	Reserved SMSC test access only	00b	R/W
13	LED Control	0 = COLST active on collision 1 = COLST active on Sync/polarity	0	R/W
12	MINT POL	0 = MINT output active low 1 = MINT output active high	0	R/W
11	Pol Dis	Disable 10BASE-T autopolarity correction	0	R/W
10	SQE Disable	0 = SQE generation (normal operation) 1 = No SQE generation	0	R/W
9	JAB Disable	0 = In case of jabber the 10BASE-T will cut the frame (normal operation) 1 = Jabber function disable	0	R/W
8	Loop 10	Disable loopback of TX to RX in 10BASE-T half duplex	0	R/W
7	Force RX	Force reception regardless of link	0	R/W
6	Force TX	Force transmission regardless of link	0	R/W
5	CRS_CTL	CRS behavior in FDX – 0 = CRS is active during transmission only 1 = CRS active during reception only	0	R/W
4	MF	0 = Normal operation 1 = Disable the MD preamble function	0	R/W
3	Byp ALIGN	0 = Normal operation 1 = Bypass the aligner function	0	R/W
2	Byp ENC	0 = Normal operation 1 = Bypass the 4B5B encoder function	0	R/W
1	Byp SCR	0 = Normal operation 1 = Bypass the 4B5B scrambler function	0	R/W
0	DISCEN	Disconnect mechanism enable	0 – DTE 1 – RPT	

Reg 25 - ANEG Status

BIT	BIT NAME	DESCRIPTION	DEFAULT	TYPE
15	Reserved	Test mode only - do not set high	0	R/W
14	Reserved	Test mode only - do not set high	0	R/W
13	Pol	10BASE-T polarity sense	0	RO
12:8	PA	PHY address	PA<4:0>	RO
7	Aneg complete	0 = Aneg completed 1 = Aneg did not complete (same as 1.5)	0	RO
6	Duplex	ANEG result - duplex operation 0 = HDX, 1 = FDX	0	RO
5	Speed	ANEG result - speed of operation 0 = 10, 1 = 100	0	RO
4	Ability mtc	1 = abilities matched	0	RO
0:3	ANEG state	ANEG state machine current state	0	RO

Reg 26 - Symbol Error Counter

BIT	BIT NAME	DESCRIPTION	DEFAULT	TYPE
15:0	RX_ERR counter	Number of RX_ERR events since last read – clears either in change of speed or read of this reg.	0	RO SC

Reg 27 - False Carrier Event Counter

BIT	BIT NAME	DESCRIPTION	DEFAULT	TYPE
15	Disconnect	The disconnect mechanism status	0	RO LH
14:18	Reserved		0	RO
7:0	False CRS counter	Number of False CRS events since last read. Active only in repeater 100 mode.	0	RO SC

Reg 28 - Counter Test Register

BIT	BIT NAME	DESCRIPTION	DEFAULT	TYPE
15:0	Reserved	Test mode only	0000h	Res

OPERATING CONDITIONS

MAXIMUM GUARANTEED RATINGS*

Operating Temperature Range	0° C to +70° C
Storage Temperature Range	-40° C to +125° C
Lead Temperature Range (soldering, 10 seconds)	+TBD° C
Positive Voltage on any pin, with respect to Ground	V _{DD} + 0.5V
Negative Voltage on any pin, with respect to Ground	-0.5V
Maximum V _{DD}	+7.0V

*Stresses above those listed above could cause permanent damage to the device. This is a stress rating only and functional operation of the device at any other condition above those indicated in the operation sections of this specification is not implied.

Note: When powering this device from laboratory or system power supplies, it is important that the Absolute Maximum Ratings not be exceeded or device failure can result. Some power supplies exhibit voltage spikes on their outputs when the AC power is switched on or off. In addition, voltage transients on the AC power line may appear on the DC output. If this possibility exists, it is suggested that a clamp circuit be used.

DC ELECTRICAL CHARACTERISTICS

(T_A = 0° C - 70° C, V_{DD} = +5.0V ±5%)

CHARACTERISTIC	SYMBOL	VALUE		UNITS	CONDITIONS
		MIN	MAX		
DC PARAMETERS – INPUT					
High Level Input Voltage	V _{IH}	2	V _{DD}	V	No pull-up including package
High Level Input Voltage	V _{IL}	V _{SS}	0.8	V	
High Level Input Current	I _{IH}	-	1	µA	
High Level Input Current	I _{IL}	-	-1	µA	
Pin Capacitance To Ground		-	8	pF	
DC PARAMETERS - OUTPUT - 6MA BUFFERS					
High Level Output Voltage	V _{OH}	4	V _{DD}	V	0.4V to 2.4V into 20pF load
High Level Output Voltage	V _{OL}	V _{SS}	0.4	V	
High Level Output Current	I _{OH}	-	-6	mA	
High Level Output Current	I _{OL}	-	6	mA	
Rise Time		-	4	nS	
Fall Time		-	4	nS	
Pin Capacitance To Ground		-	8	pF	
DC PARAMETERS – SUPPLY CURRENT					
10 Base-T Idle			90	mA	Measured at 5V, room temperature. These figures include the current flowing in the Transmit load resistors.
10 Base-T Active			180	mA	
100 Base TX Mode			120	mA	
Auto Negotiation			90	mA	
Low Power			35	mA	

DIFFERENTIAL OUTPUT

Recommended operating conditions apply except where stated.

CHARACTERISTIC	SYMBOL	VALUE		UNITS	CONDITIONS
		MIN	MAX		
High level		2	-	V	
Zero level		-50	50	mV	
Low level		-	-2	V	
Current at		Typical = V _{DD} /2		µA	
Slew rate		-	0.5	V/ns	

AC ELECTRICAL CHARACTERISTICS

Recommended operating conditions apply except where stated.

CHARACTERISTIC	VALUE		UNITS	CONDITIONS
	MIN	MAX		
REFCLK				
Frequency	25±100ppm		MHz	
Duty cycle	45	55	%	
RX_CLK				
Frequency	25±100ppm		MHz	100Mbps mode
Duty cycle	40	60	%	100Mbps mode
Frequency	2.5±100ppm		MHz	10Mbps mode
Duty cycle	40	60	%	10Mbps mode
TX_CLK				
Frequency	25±100ppm		MHz	100Mbps mode
Duty cycle	40	60	%	100Mbps mode
Frequency	2.5±100ppm		MHz	10Mbps mode
Duty cycle	40	60	%	10Mbps mode
MDC				
Frequency	-	2.5	MHz	
Minimum high/low	160	-	ns	

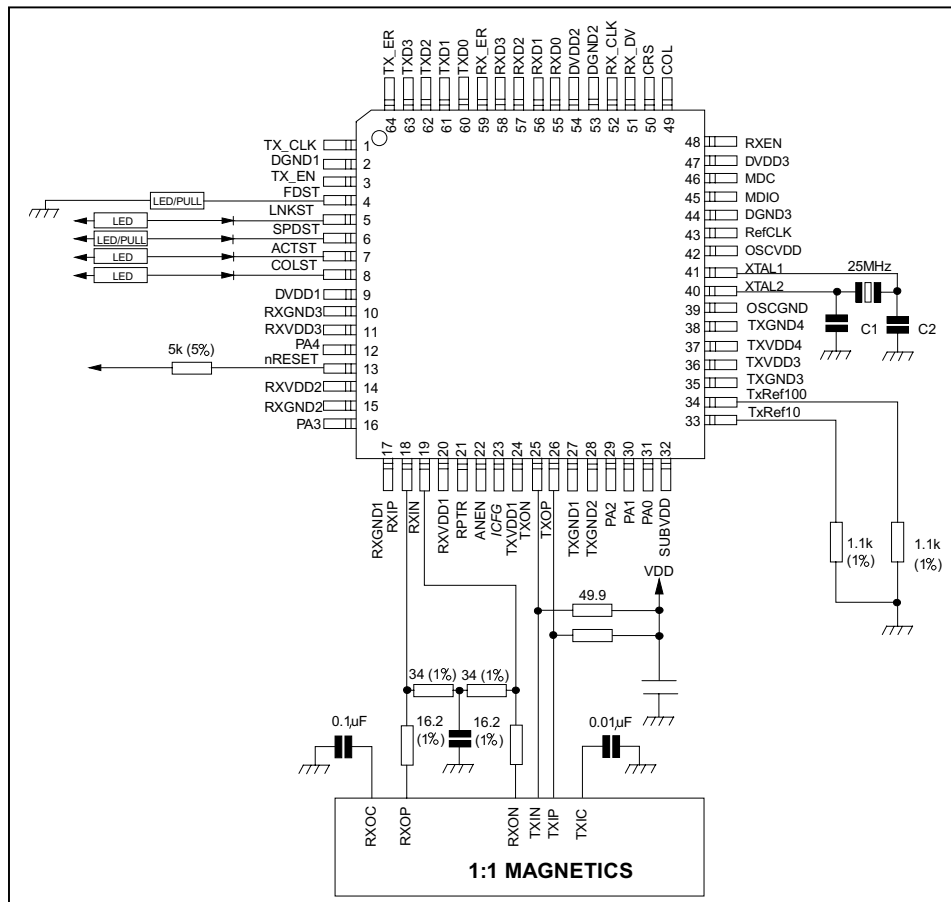

FIGURE 3 - EXTERNAL COMPONENTS

EXTERNAL COMPONENTS

Connecting an External 25MHz Reference

If an external clock is used then it should be driven into the REFCLK input, and XTAL1 must be connected to OSCVDD. XTAL2 must be left unconnected.

nRESET Pull-up Resistor

This resistor is required regardless of whether nRESET is used externally.

RX Input Decoupling

The method of using a split input load resistor and de-coupling the center tap reduces common mode noise.

Crystal Oscillator

For IEEE802.3 compliance the oscillator must run at 25MHz \pm 100ppm. The LAN83C180 on-chip circuitry contributes less than 40ppm variability to the oscillator frequency, therefore the crystal must be specified to 60ppm. This must include variations due to temperature and aging.

External capacitors are required on the XTAL1 & XTAL2 pins. The values of these capacitors are dependent on the power dissipation and the equivalent series resistance of the chosen crystal, as follows:

Let P_C = power dissipation of the crystal in mW,
and ESR = equivalent series resistance of the crystal in Ω .

If $P_C > 2.6\text{mW}$ then C_1 & C_2 are determined by the loop gain:

$$C_1 = C_2 = \frac{184}{\sqrt{ESR}} - 7\text{pF}$$

If $P_C < 2.6\text{mW}$ then C_1 & C_2 are determined by the power dissipation of the crystal:

$$C_1 = C_2 = 114 \sqrt{\frac{P_C}{ESR}} - 7\text{pF}$$

Tracking to the crystal and the capacitors must be as short as possible. Other signal paths must not cross the area.

The LAN83C180 is supported by magnetics from the following vendors:

VENDOR	MAGNETICS
Bel	S558-5999-39
Pulse	H1012
Valor	ST6118
HALO	TG110-S050N2
HALO	TG22-3506ND

PACKAGE DETAILS

Dimensions are shown: mm (in).

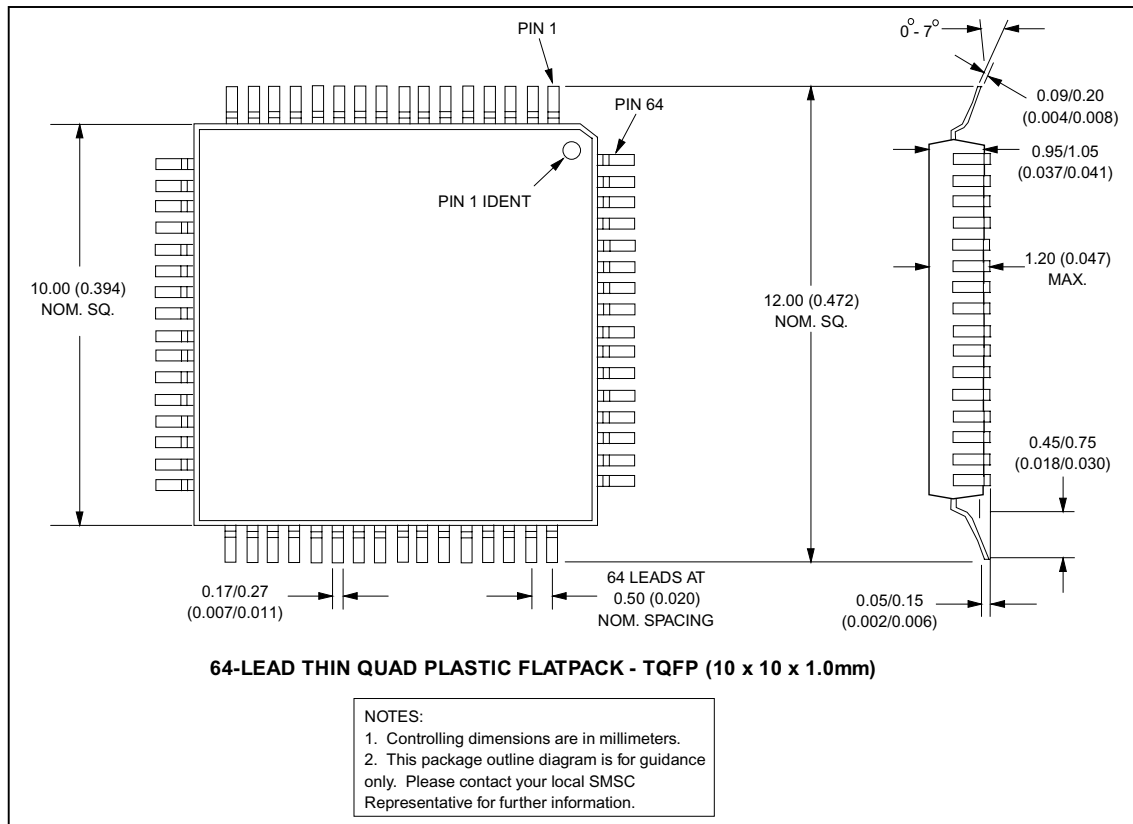

FIGURE 4 – LAN83C180 PACKAGE OUTLINE

LAN83C180 REVISIONS

PAGE(S)	SECTION/FIGURE/ENTRY	CORRECTION	DATE REVISED
14	Reg 3 - LAN83C180 Identifier Register	Default value changed from 1C51h to 1C52h	08/24/01
5	Description of Pin Functions	Pin # 39 added, OSCGND - see italicized text	11/16/00
11	ICFG Interrupt	Added section	09/14/00
16	Reg. 21, Reg. 24	See Italicized Text	12/02/99
4	Pin Configuration	See Italicized Text	2/11/99
4	Figure 1	See Italicized Text	2/11/99
5, 6	Description of Pin Functions	See Italicized Text	2/11/99
10	First Paragraph under Block Table	See Italicized Text	2/11/99
12	Transmitter Output Enable (TXOE)	Paragraph Removed	2/11/99
18	DC Electrical Characteristics/ DC Parameters – Supply Current	See Italicized Text	2/11/99
19	Figure 3/Pin 23	See Italicized Text	2/11/99
20	Table	See Italicized Text	2/11/99