



PLASMA DISPLAY PANEL SCAN DRIVER

FEATURES

- 64 OUTPUTS PLASMA DISPLAY DRIVER
- 170V ABSOLUTE MAXIMUM SUPPLY
- 5V SUPPLY FOR LOGIC
- 100/400 mA SOURCE / SINK OUTPUT
- 700 mA SOURCE / SINK OUTPUT DIODE
- 64-BIT SHIFT REGISTER (20 MHz)
- BLANK CONTROL
- COMPLEMENTARY OUTPUT CONTROL
- BCD TECHNOLOGY
- 100 PINS PQFP PACKAGE OR DICE.

DESCRIPTION

The STV7697A is a scan driver for Plasma Display Panel (PDP) implemented in ST's proprietary BCD technology. Using a 64-bit cascadable 20 MHz shift register, it drives 64 high current & high voltage outputs. By serially connecting several STV7697A, any vertical pixel definition can be performed. The STV7697A is supplied with a separated 160V power output supply and a 5V logic supply. All command inputs are CMOS compatible.

The STV7697A package is a 100 pins PQFP.

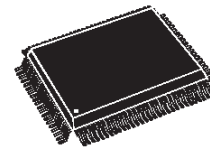

PQFP100 (14 x 20 x 2.80 mm)
(Full Plastic Quad Flat Pack)

ORDER CODE: STV7697A



ORDER CODE: STV7697A/WAF (1)
(1): Unsawn Tested Wafer

TABLE OF CONTENTS

PIN ASSIGNMENT	4
BLOCK DIAGRAM	7
CIRCUIT DESCRIPTION	7
Note 1 ABSOLUTE MAXIMUM RATINGS	8
Note 1 THERMAL DATA	8
Note 5 ELECTRICAL CHARACTERISTICS	9
Note 6 AC TIMINGS REQUIREMENTS	10
Note 6 AC TIMINGS CHARACTERISTICS	10
Figure 2. INPUT/OUTPUT SCHEMATICS	13
Figure 6. PACKAGE MECHANICAL DATA	14

PIN CONNECTIONS

(Die pinout)

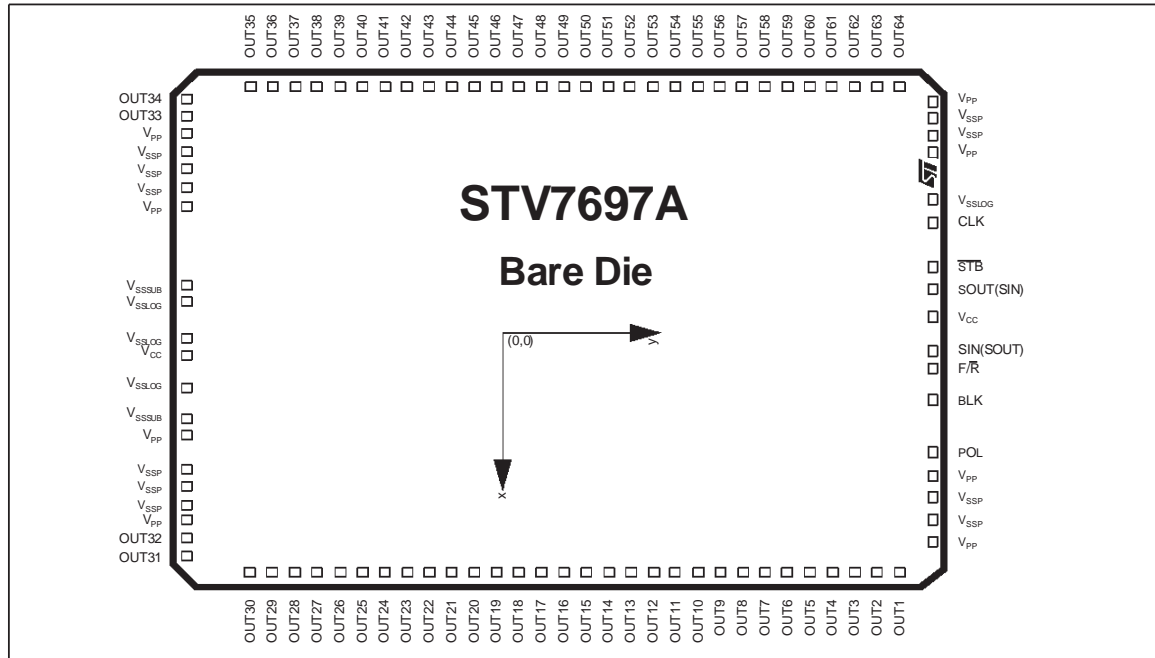

PIN CONNECTIONS

(TQFP pinout)

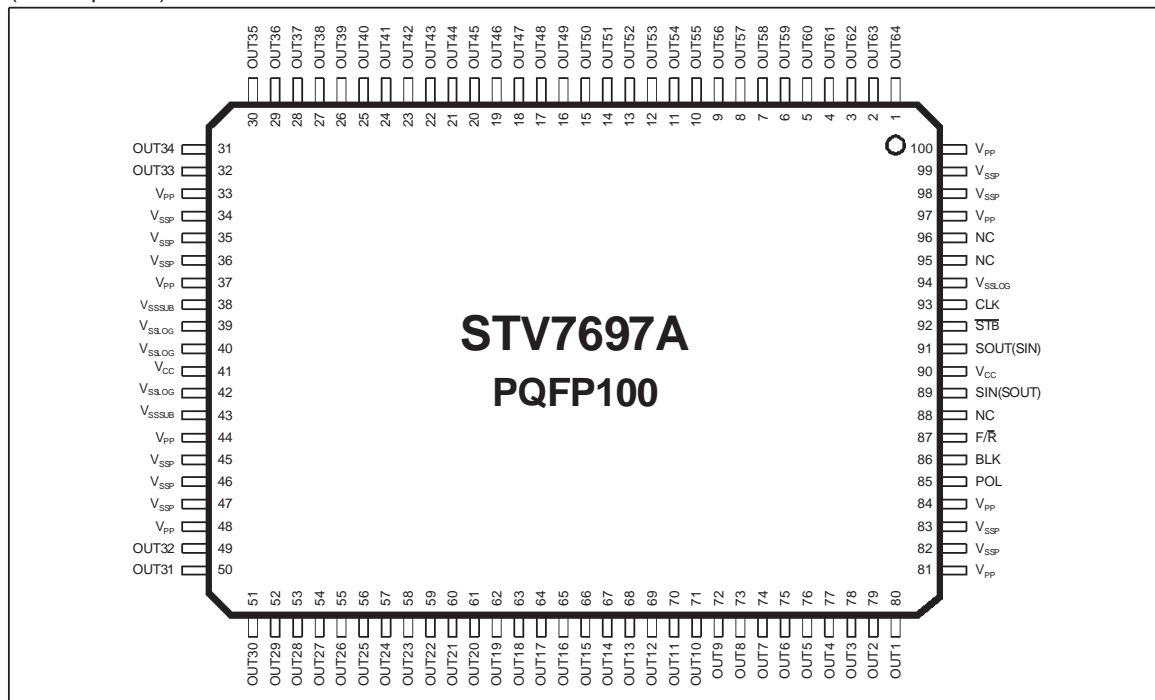

PIN ASSIGNMENT

(TQFP100)

Pin Number	Symbol	Type	Function
33-37-44-48-81-84-97-100	V _{PP}	Supply	High Voltage Supply of power outputs
41 - 90	V _{CC}	Supply	5 V Logic Supply
34-35-36-45-46-47-82-83-98-99	V _{SSP}	Ground	Ground of power outputs
38-43	V _{SSSUB}	Ground	Substrate Ground
39-40-42-94	V _{SSLOG}	Ground	Logic Ground
1 to 32, 49 to 80	OUT 64 to OUT 1	Output	Power Output
91	SOUT (SIN)	Output	Shift Register Data Output (forward)
85	POL	Input	Polarity Selection
86	BLK	Input	Output Blanking Command
87	F/R	Input	Selection of shift direction
89	SIN (SOUT)	Input	Shift Register Data Input (forward)
92	$\overline{\text{STB}}$	Input	Latch of data to outputs
93	CLK	Input	Clock of data shift register
88-95-96	NC	-	

PIN ASSIGNMENT (Power Outputs)

Output N°	Pin N°	Output N°	Pin N°	Output N°	Pin N°	Output N°	Pin N°
1	80	17	64	33	32	49	16
2	79	18	63	34	31	50	15
3	78	19	62	35	30	51	14
4	77	20	61	36	29	52	13
5	76	21	60	37	28	53	12
6	75	22	59	38	27	54	11
7	74	23	58	39	26	55	10
8	73	24	57	40	25	56	9
9	72	25	56	41	24	57	8
10	71	26	55	42	23	58	7
11	70	27	54	43	22	59	6
12	69	28	53	44	21	60	5
13	68	29	52	45	20	61	4
14	67	30	51	46	19	62	3
15	66	31	50	47	18	63	2
16	65	32	49	48	17	64	1

PADS DIMENSIONS (in μm)/ PADS POSITIONSThe reference is the centre of the die ($x=0, y=0$)

TOP SIDE from left to right

Name	Centre:X	Centre:Y	Size:x	Size: y
V _{PP}	-2468.5	4135.0	75.0	90.0
V _{SSP}	-2313.5	4135.0	75.0	90.0
V _{SSP}	-2188.5	4135.0	75.0	90.0
V _{PP}	-2063.5	4134.5	75.0	90.0
V _{SSLOG}	-1620.0	4135.0	75.0	90.0
CLK	-1430.0	4135.0	75.0	90.0
STB	-781.0	4135.0	75.0	90.0
SOUT	-612.5	4135.0	75.0	90.0
V _{CC}	-335.5	4144.5	75.0	90.0
SIN	379.5	4135.0	75.0	90.0
F/R	548.0	4135.0	75.0	90.0
BLK	1082.0	4135.0	75.0	90.0
POL	1853.0	4135.0	75.0	90.0
V _{PP}	2021.5	4140.0	75.0	90.0
V _{SSP}	2156.5	4140.0	75.0	90.0
V _{SSP}	2291.5	4140.0	75.0	90.0
V _{PP}	2454.5	4129.5	75.0	90.0

BOTTOM SIDE from left to right

Name	Centre:X	Centre:Y	Size:x	Size: y
OUT34	-2468.0	-4087.5	75.0	90.0
OUT33	-2318.0	-4089.5	75.0	90.0
V _{PP}	-2182.0	-4089.5	75.0	90.0
V _{SSP}	-2047.0	-4093.0	75.0	90.0
V _{SSP}	-1912.0	-4093.0	75.0	90.0
V _{SSP}	-1777.0	-4093.0	75.0	90.0
V _{PP}	-1642.0	-4089.5	75.0	90.0
V _{SSSUB}	-683.0	-4088.0	75.0	90.0
V _{SSLOG}	-382.5	-4088.0	75.0	90.0
V _{SSLOG}	419.5	-4087.5	75.0	90.0
V _{CC}	618.5	-4087.5	75.0	90.0
V _{SSLOG}	951.0	-4087.5	75.0	90.0
V _{SSSUB}	1308.0	-4087.5	75.0	90.0

BOTTOM SIDE from left to right (continued)

Name	Centre:X	Centre:Y	Size:x	Size: y
V _{PP}	1438.5	-4087.5	75.0	90.0
V _{SSP}	1797.5	-4093.5	75.0	90.0
V _{SSP}	1932.5	-4093.5	75.0	90.0
V _{SSP}	2067.5	-4093.5	75.0	90.0
V _{PP}	2193.0	-4093.5	75.0	90.0
OUT32	2318.0	-4093.5	75.0	90.0
OUT31	2468.5	-4093.5	75.0	90.0

RIGHT SIDE from top to bottom

Name	Centre:X	Centre:Y	Size:x	Size: y
OUT1	2647.0	3697.0	90.0	75.0
OUT2	2647.0	3484.0	90.0	75.0
OUT3	2647.0	3238.5	90.0	75.0
OUT4	2647.0	2992.5	90.0	75.0
OUT5	2647.0	2743.0	90.0	75.0
OUT6	2647.0	2506.5	90.0	75.0
OUT7	2647.0	2264.0	90.0	75.0
OUT8	2647.0	2018.0	90.0	75.0
OUT9	2647.0	1774.5	90.0	75.0
OUT10	2647.0	1529.0	90.0	75.0
OUT11	2647.0	1285.5	90.0	75.0
OUT12	2647.0	1040.0	90.0	75.0
OUT13	2647.0	796.5	90.0	75.0
OUT14	2647.0	551.0	90.0	75.0
OUT15	2647.0	307.5	90.0	75.0
OUT16	2647.0	62.0	90.0	75.0
OUT17	2647.0	-181.5	90.0	75.0
OUT18	2647.0	-427.0	90.0	75.0
OUT19	2647.0	-670.5	90.0	75.0
OUT20	2647.0	-916.0	90.0	75.0
OUT21	2647.0	-1159.5	90.0	75.0
OUT22	2647.0	-1405.0	90.0	75.0
OUT23	2647.0	-1648.5	90.0	75.0
OUT24	2647.0	-1894.0	90.0	75.0

RIGHT SIDE from top to bottom (continued)

Name	Centre:X	Centre:Y	Size:x	Size: y
OUT25	2647.0	-2137.5	90.0	75.0
OUT26	2647.0	-2383.5	90.0	75.0
OUT27	2647.0	-2627.0	90.0	75.0
OUT28	2647.0	-2872.5	90.0	75.0
OUT29	2647.0	-3116.0	90.0	75.0
OUT30	2647.0	-3363.0	90.0	75.0

LEFT SIDE from bottom to top (continued)

Name	Centre:X	Centre:Y	Size:x	Size: y
OUT61	-2646.5	2949.5	90.0	75.0
OUT62	-2646.5	3228.5	90.0	75.0
OUT63	-2646.5	3487.0	90.0	75.0
OUT64	-2646.5	3763.0	90.0	75.0

LEFT SIDE from bottom to top

Name	Centre:X	Centre:Y	Size:x	Size: y
OUT35	-2646.5	-3363.0	90.0	75.0
OUT36	-2646.5	-3116.0	90.0	75.0
OUT37	-2646.5	-2872.5	90.0	75.0
OUT38	-2646.5	-2627.0	90.0	75.0
OUT39	-2646.5	-2383.5	90.0	75.0
OUT40	-2646.5	-2137.5	90.0	75.0
OUT41	-2646.5	-1894.0	90.0	75.0
OUT42	-2646.5	-1648.5	90.0	75.0
OUT43	-2646.5	-1405.0	90.0	75.0
OUT44	-2646.5	-1159.5	90.0	75.0
OUT45	-2646.5	-916.0	90.0	75.0
OUT46	-2646.5	-670.5	90.0	75.0
OUT47	-2646.5	-427.0	90.0	75.0
OUT48	-2646.5	-181.5	90.0	75.0
OUT49	-2646.5	62.0	90.0	75.0
OUT50	-2646.5	307.5	90.0	75.0
OUT51	-2646.5	551.0	90.0	75.0
OUT52	-2646.5	796.5	90.0	75.0
OUT53	-2646.5	1040.0	90.0	75.0
OUT54	-2646.5	1285.5	90.0	75.0
OUT55	-2646.5	1529.0	90.0	75.0
OUT56	-2646.5	1774.5	90.0	75.0
OUT57	-2646.5	2018.0	90.0	75.0
OUT58	-2646.5	2264.0	90.0	75.0
OUT59	-2646.5	2506.5	90.0	75.0
OUT60	-2646.5	2743.0	90.0	75.0

BLOCK DIAGRAM

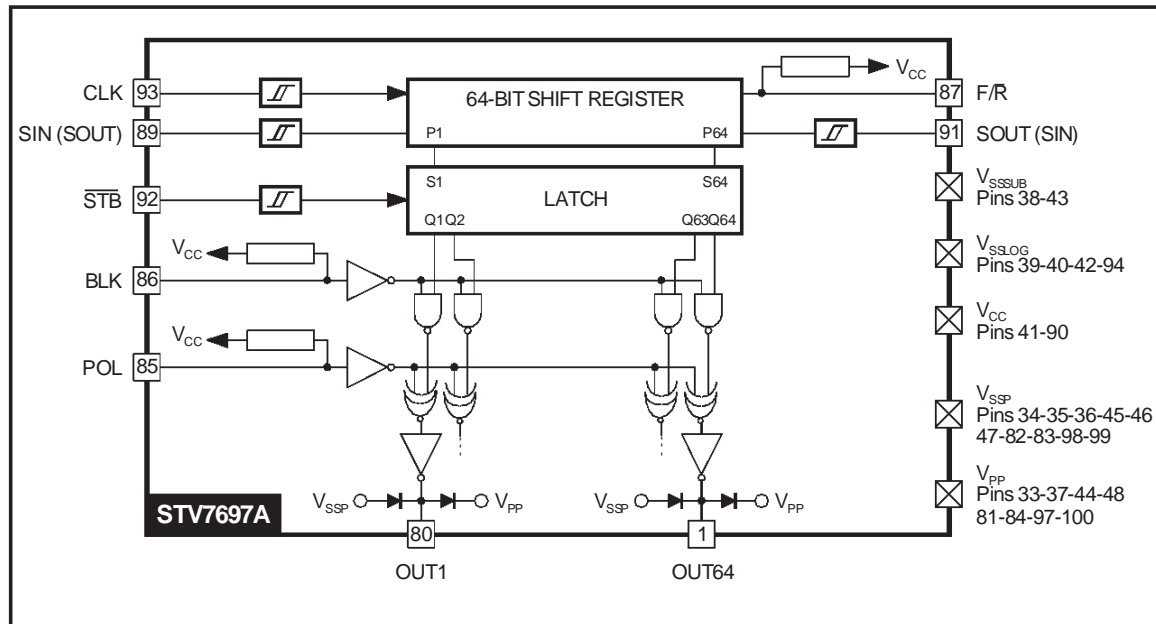

CIRCUIT DESCRIPTION

The STV7697A contains all the logic and the power circuits necessary to drive rows of a Plasma Display Panel (P. D. P.). The state of the displayed line is loaded into the shift register. Data are shifted at each low to high transition of the (CLK) shift clock. After 64 shifts the first bit is available at the serial output. This output can be used to cascade several drivers to perform any vertical resolution.

The forward / reverse (F/R) input is used to select the direction of the shift register, data input/output status is set according to the selected direction. SIN, CLK, STB inputs

are Smith trigger inputs. If not used on the application, F/R, BLK, POL logical inputs are internally pulled to level "1". The maximum frequency of the shift clock is 20 MHz.

All the data are memorized into the latch stage when the strobe input (STB) is pulled high.

Blanking input (BLK) forces the power outputs to high level when pulled high with polarity input

(POL) at high level and forced to low level with POL at low level.

The level of the power output is inverted when the polarity command (POL) is pulled high.

Sustain current must not be sunk in the power output to V_{PP} when the power supply is applied.

V_{SSLOG} and V_{SSSUB} must be connected as close as possible to the logical reference ground of the application.

Shift Register Truth Table

Input		Input/Output		Shift Register Function
F/R	CLK	SIN	SOUT	Output Q
H	Rise	IN	OUT	Forward Shift
H	H or L	IN	OUT	Steady
L	Rise	OUT	IN	Reverse Shift
L	H or L	OUT	IN	Steady

Power Output Truth Table

Qn (1)	\overline{STB}	BLK	POL	Driver Output	Comments
X	X	H	H	All H	Forced to High
X	X	H	L	All L	Forced to Low
H	L	L	L	H	Copy Data
L	L	L	L	L	Copy Data
H	L	L	H	L	Copy Inverted Data
L	L	L	H	H	Copy Inverted Data
X	H	L	L	Qn	Data Latched
X	H	L	H	\overline{Qn}	Inverted Data Latched

Note 1 Qn is the parallel output of the shift register (n = 1 to 64). Qn takes the value of serial input (SIN) after "n" shift clock periods.

ABSOLUTE MAXIMUM RATINGS

Symbol	Parameter	Value	Unit
V _{CC}	Logic Supply Range	-0.3, +7	V
V _{PP}	Driver Supply Range	-0.3, +170	V
V _{IN}	Logic Input Voltage Range	-0.3, V _{CC} + 0.3	V
V _{OUT}	Logic Output Voltage Range	-0.3, V _{CC} + 0.3	V
V _{POUT}	Driver Output Voltage Range	-0.3, V _{PP}	V
I _{POUT}	Driver Output Current (3) (5)	+100/-400	mA
I _{DOUT}	Diode Output Current (4) (5)	±700	mA
T _{jmax}	Operating Temperature	-20, +85	°C
T _{oper}	Junction Temperature (2)	+125	°C
T _{stg}	Storage Temperature	-50,+150	°C

THERMAL DATA

Symbol	Parameter	Value	Unit
R _{th(j-a)}	Junction-ambient Thermal Resistance (2)	Max 50	°C/W
P _{oper}	Operating Power Dissipation (T _{amb} = 25°C)	Max 2	W
T _{joper}	Operating Junction Temperature (2)	Max +125	°C

Note 2 For PQFP100 packaging.

Note 3 Through one power output.

Note 4 Through one power output with V_{PP} = V_{SSP} (see test diagram).

Note 5 These parameters are measured during ST's internal qualification which includes temperature characterisation on standard batches and on corners batches of the process. These parameters are not tested on the parts.

ELECTRICAL CHARACTERISTICS

($V_{CC} = 5\text{ V}$, $V_{PP} = 160\text{ V}$, $V_{SSP} = 0\text{ V}$, $V_{SSLOG} = V_{SSSUB} = 0\text{ V}$, $T_{amb} = 25^{\circ}\text{C}$, $f_{CLK} = 20\text{ MHz}$, unless otherwise specified)

Symbol	Parameter	Test Conditions	Min.	Typ.	Max.	Unit
--------	-----------	-----------------	------	------	------	------

SUPPLY

V_{CC}	Logic Supply Voltage		4.5	5	5.5	V
I_{CCH}	Logic Supply Current (all inputs high)		-	-	100	μA
I_{CCL}	Logic Supply Current	$f_{CLK} = 8\text{ MHz}$, $SIN = 1010$	-	5.3	-	mA
V_{PP}	Power Output Supply Voltage		15	-	160	V
I_{PPH}	Power Output Supply Current (steady outputs)		-	-	100	μA

OUTPUT

OUT1-OUT64						
V_{POUTH}	Power Output High Level (voltage drop versus V_{PP})	$I_{POUTH} = -10\text{ mA}$ $I_{POUTH} = -40\text{ mA}$	10 -	- 5	- -	V V
V_{POUTL}	Power Output Low Level	$I_{POUTL} = 200\text{ mA}$	-	3.1	10	V
V_{DOUTH}	Output Diode High Level	$I_{DOUTH} = +400\text{ mA (5)}$	-	2.3	10	V
V_{DOUTL}	Output Diode Low Level	$I_{DOUTL} = -400\text{ mA (5)}$	-10	-2.2	-	V
SOUT						
V_{OH}	Logic Output High Level	$I_{OH} = 1\text{ mA}$	4	-	-	V
V_{OL}	Logic Output Low Level	$I_{OL} = -1\text{ mA}$	-	-	0.4	V

INPUT (CLK, F/R, \overline{STB} , POL, BLK, SIN,)

V_{IH}	Input High Level		$0.8 V_{CC}$	-	-	V
V_{IL}	Input Low Level		-	-	$0.2V_{CC}$	V
I_{IH}	High Level Input Current	$V_{IH} = V_{CC}$	-	-	10	μA
I_{IL}	Low Level Input Current CLK, SIN, \overline{STB} , F/R, BLK, POL	$V_{IL} = 0\text{ V}$	- -	- 70	10 100	μA μA

Note 6 Compatible with power dissipation (see test diagram).

AC TIMINGS REQUIREMENTS

($V_{CC} = 4.5\text{ V to }5.5\text{ V}$, $T_{amb} = -20\text{ to }+85^{\circ}\text{C}$, input signals max leading edge & trailing edge (t_R , t_F) = 10 ns)

Symbol	Parameter	Min.	Typ.	Max.	Unit
t_{CLK}	Data Clock Period	50	-	-	ns
t_{WHCLK}	Duration of clock (CLK) pulse at high level	15	-	-	ns
t_{LHCLK}	Duration of clock (CLK) pulse at low level	15	-	-	ns
t_{SDAT}	Set-up Time of data input before clock low to high transition	10	-	-	ns
t_{HDAT}	Hold Time of data input after clock low to high transition	10	-	-	ns
t_{SFR}	Forward/reverse (F/R) Set-up Time before low to high transition	100	-	-	ns
t_{DSTB}	Minimum Delay to latch \overline{STB} after clock low to high transition	10	-	-	ns
t_{STB}	Strobe \overline{STB} Pulse Duration	20	-	-	ns
t_{BLK}	Blank (BLK) Pulse Duration	500	-	-	ns
t_{POL}	Polarity (POL) Pulse Duration	500	-	-	ns

AC TIMINGS CHARACTERISTICS

($V_{CC} = 5\text{ V}$, $V_{PP} = 90\text{ V}$, $V_{SSP} = 0\text{ V}$, $V_{SSLOG} = V_{SSSUB} = 0\text{ V}$, $T_{amb} = 25^{\circ}\text{C}$, $f_{CLK} = 20\text{ MHz}$, $V_{ILMax.} = 0.2 V_{CC}$, $V_{IHMin.} = 0.8 V_{CC}$, $V_{OH} = 4.0\text{ V}$, $V_{OL} = 0.4\text{ V}$, $C_L = 15\text{ pF}$, unless otherwise specified)

Symbol	Parameter	Min.	Typ.	Max.	Unit
t_{CLK}	Data Clock Period	50	-	-	ns
t_{RDAT}	Logical Data Output Rise Time	-	20	-	ns
t_{FDAT}	Logical Data Output Fall Time	-	11	-	ns
t_{PHL1}	Delay of logic data output after clock (CLK) high to low transition	-	45	80	ns
t_{PLH1}	Delay of logic data output after clock (CLK) low to high transition	-	48	80	ns
t_{PHL2}	Delay of power output change after clock (CLK) high to low transition	-	120	180	ns
t_{PLH2}	Delay of power output change after clock (CLK) low to high transition	-	120	180	ns
t_{PHL3}	Delay of power output change after blanking (BLK) high to low transition	-	110	165	ns
t_{PLH3}	Delay of power output change after blanking (BLK) low to high transition	-	110	165	ns
t_{PHL4}	Delay of power output change after polarity (POL) high to low transition	-	-	160	ns
t_{PLH4}	Delay of power output change after polarity (POL) low to high transition	-	-	160	ns
t_{ROUT}	Power Output Rise Time (7)	-	100	200	ns
t_{FOUT}	Power Output Fall Time (7)	-	60	200	ns

Note 7 One output among 64, loading capacitor $C_{OUT} = 100\text{ pF}$, other outputs at low level.

Figure 1. AC Characteristics Waveform

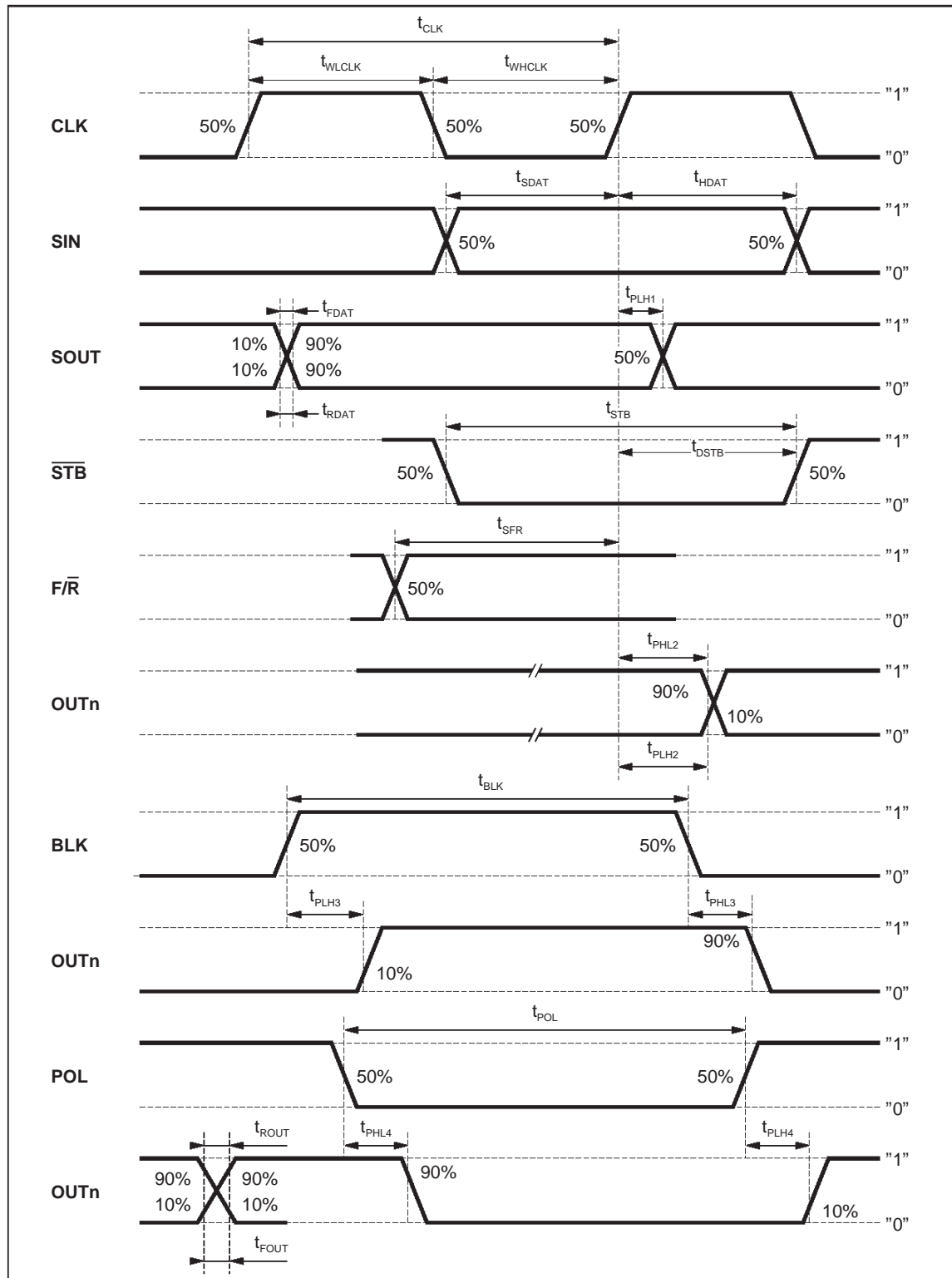
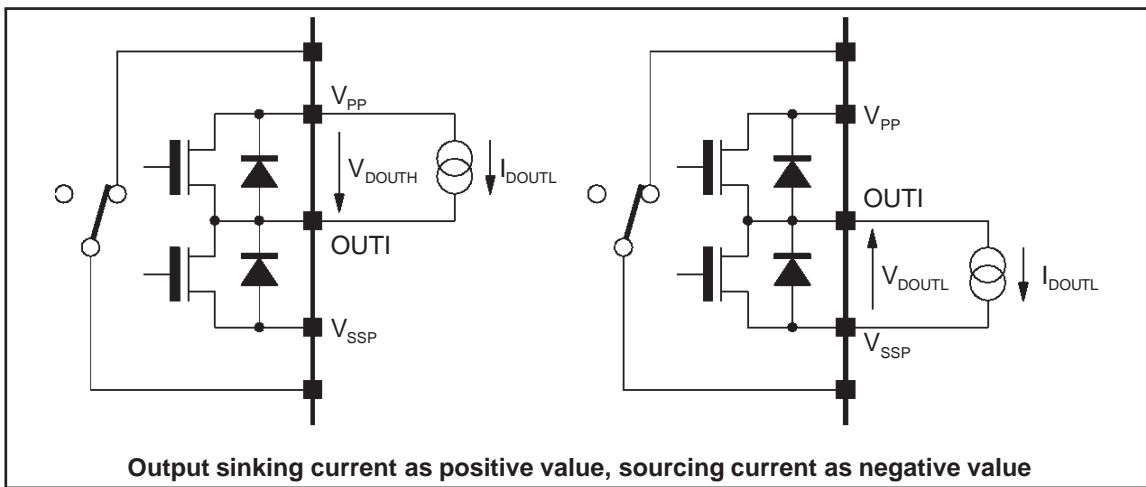

Figure 2. Test Configuration



INPUT/OUTPUT SCHEMATICS

Figure 3. F/\bar{R} , BLK, POL, HIZ

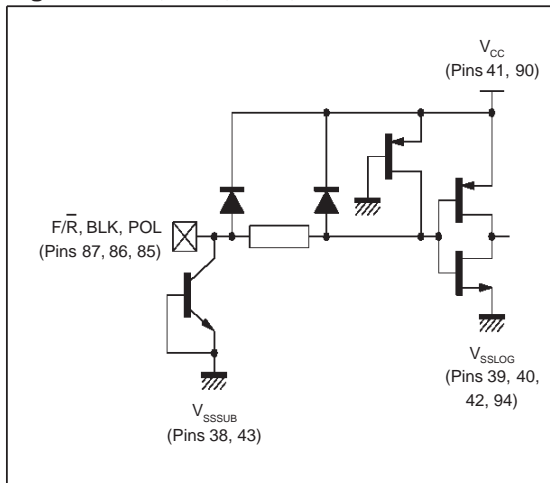

Figure 4. CLK, \overline{STB}

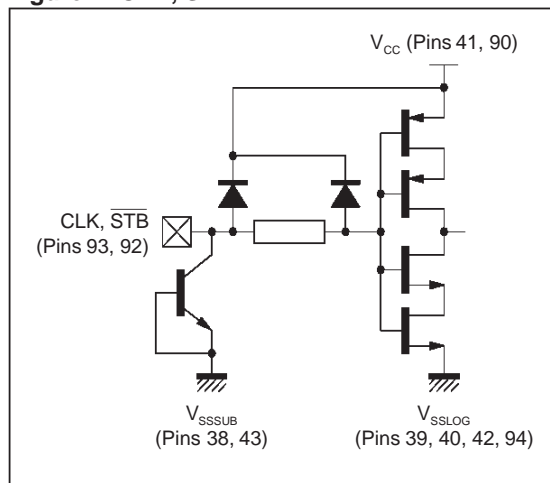

Figure 5. SIN, SOUT Input

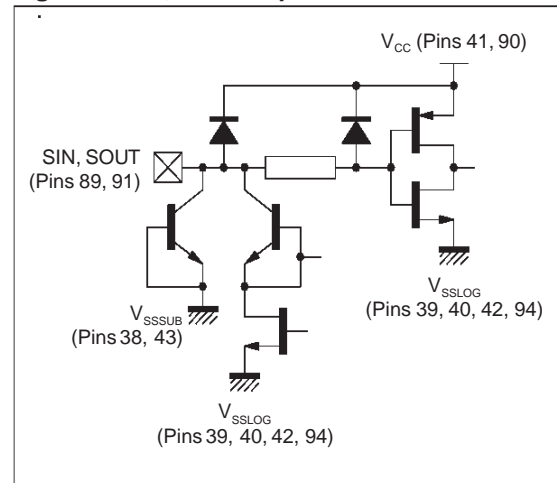
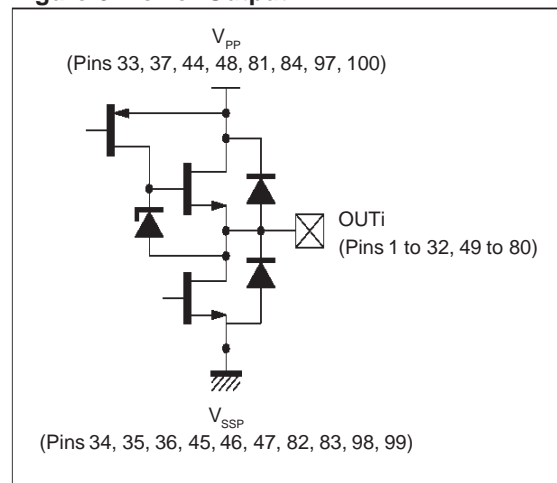
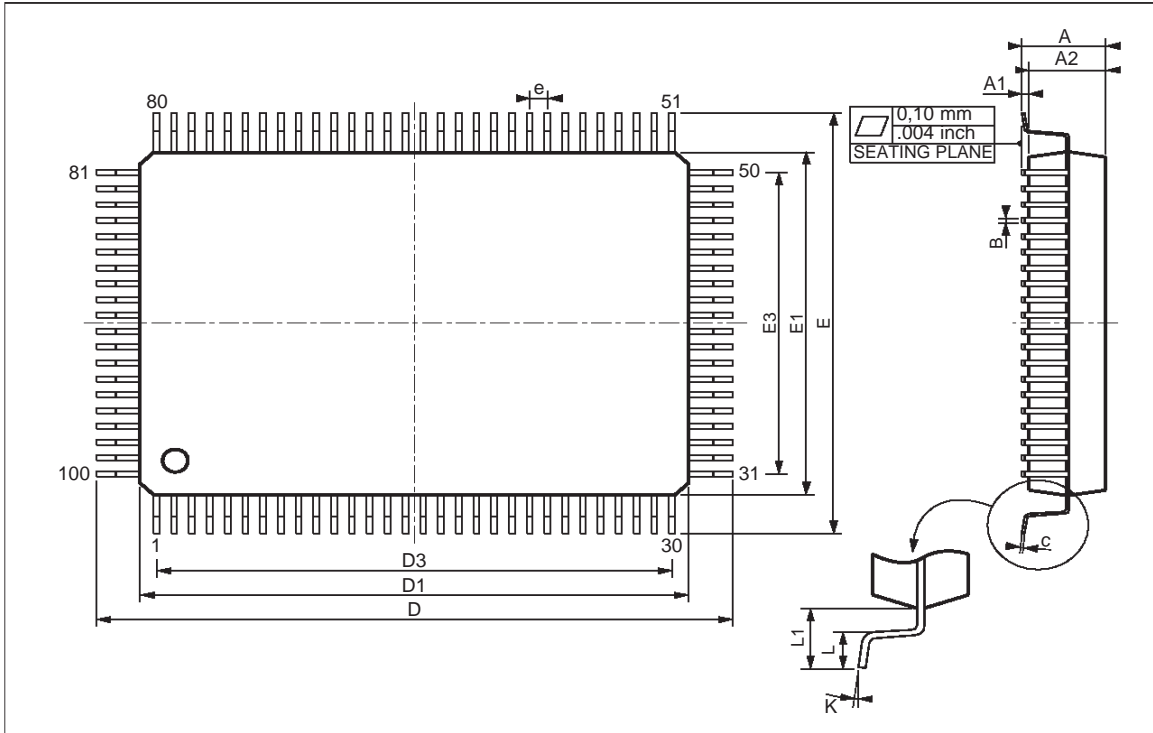

Figure 6. Power Output



PACKAGE MECHANICAL DATA

100 PINS - THIN PLASTIC QUAD FLAT PACK (PQFP100)



Dimensions	Millimeters			Inches		
	Min.	Typ.	Max.	Min.	Typ.	Max.
A			3.40			0.134
A1	0.25			0.010		
A2	2.55	2.80	3.05	0.100	0.110	0.120
B	0.22		0.38	0.0087		0.015
C	0.13		0.23	0.005		0.009
D	22.95	23.20	23.45	0.903	0.913	0.923
D1	19.90	20.00	20.10	0.783	0.787	0.791
D3		18.85			0.742	
e		0.65			0.026	
E	16.95	17.20	17.45	0.667	0.677	0.687
E1	13.90	14.00	14.10	0.547	0.551	0.555
E3		12.35			0.486	
L	0.65	0.80	0.95	0.026	0.031	0.037
L1		1.60			0.063	
K	0° (Min.), 7° (Max.)					

Information furnished is believed to be accurate and reliable. However, STMicroelectronics assumes no responsibility for the consequences of use of such information nor for any infringement of patents or other rights of third parties which may result from its use. No license is granted by implication or otherwise under any patent or patent rights of STMicroelectronics. Specifications mentioned in this publication are subject to change without notice. This publication supersedes and replaces all information previously supplied. STMicroelectronics products are not authorized for use as critical components in life support devices or systems without express written approval of STMicroelectronics.

The ST logo is a trademark of STMicroelectronics.

© 2000 STMicroelectronics - All Rights Reserved

Purchase of I²C Components of STMicroelectronics, conveys a license under the Philips I²C Patent. Rights to use these components in a I²C system, is granted provided that the system conforms to the I²C Standard Specifications as defined by Philips.

STMicroelectronics GROUP OF COMPANIES

Australia - Brazil - China - Finland - France - Germany - Italy - Japan - Korea - Malaysia - Malta - Mexico - Morocco - The Netherlands - Singapore - Spain - Sweden - Switzerland - Taiwan - Thailand - United Kingdom - U.S.A.

<http://www.st.com>

