

Features

• ENHANCEMENTS

- ispLSI 2096A is Fully Form and Function Compatible to the ispLSI 2096, with Identical Timing Specifications and Packaging
- ispLSI 2096A is Built on an Advanced 0.35 Micron E²CMOS[®] Technology

• HIGH DENSITY PROGRAMMABLE LOGIC

- 4000 PLD Gates
- 96 I/O Pins, Six Dedicated Inputs
- 96 Registers
- High Speed Global Interconnect
- Wide Input Gating for Fast Counters, State Machines, Address Decoders, etc.
- Small Logic Block Size for Random Logic

• HIGH PERFORMANCE E²CMOS[®] TECHNOLOGY

- $f_{max} = 125$ MHz Maximum Operating Frequency
- $t_{pd} = 7.5$ ns Propagation Delay
- TTL Compatible Inputs and Outputs
- Electrically Erasable and Reprogrammable
- Non-Volatile
- 100% Tested at Time of Manufacture
- Unused Product Term Shutdown Saves Power

• IN-SYSTEM PROGRAMMABLE

- In-System Programmable (ISP[™]) 5V Only
- Increased Manufacturing Yields, Reduced Time-to-Market and Improved Product Quality
- Reprogram Soldered Devices for Faster Prototyping

• OFFERS THE EASE OF USE AND FAST SYSTEM SPEED OF PLDs WITH THE DENSITY AND FLEXIBILITY OF FIELD PROGRAMMABLE GATE ARRAYS

- Complete Programmable Device Can Combine Glue Logic and Structured Designs
- Enhanced Pin Locking Capability
- Three Dedicated Clock Input Pins
- Synchronous and Asynchronous Clocks
- Programmable Output Slew Rate Control to Minimize Switching Noise
- Flexible Pin Placement
- Optimized Global Routing Pool Provides Global Interconnectivity
- Lead-Free Package Options

Functional Block Diagram

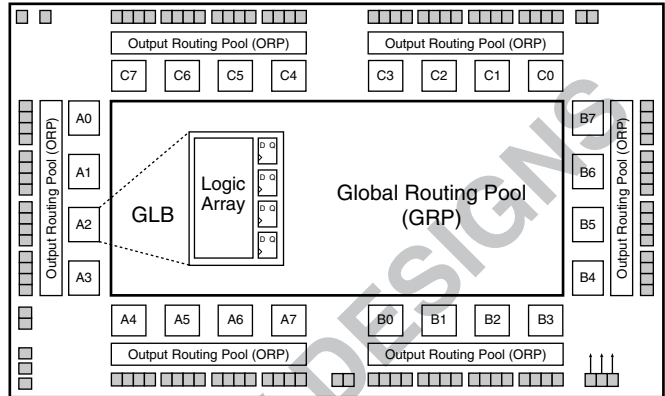

Description

The ispLSI 2096 and 2096A are High Density Programmable Logic Devices. The devices contain 96 Registers, 96 Universal I/O pins, six Dedicated Input pins, three Dedicated Clock Input pins, two dedicated Global OE input pins and a Global Routing Pool (GRP). The GRP provides complete interconnectivity between all of these elements. The ispLSI 2096 and 2096A feature 5V in-system programmability and in-system diagnostic capabilities. The ispLSI 2096 and 2096A offer non-volatile reprogrammability of the logic, as well as the interconnect to provide truly reconfigurable systems.

The basic unit of logic on these devices is the Generic Logic Block (GLB). The GLBs are labeled A0, A1...C7 (Figure 1). There are a total of 24 GLBs in the ispLSI 2096 and 2096A devices. Each GLB is made up of four macrocells. Each GLB has 18 inputs, a programmable AND/OR/Exclusive OR array, and four outputs which can be configured to be either combinatorial or registered. Inputs to the GLB come from the GRP and dedicated inputs. All of the GLB outputs are brought back into the GRP so that they can be connected to the inputs of any GLB on the device.

Functional Block Diagram

Figure 1. ispLSI 2096/A Functional Block Diagram

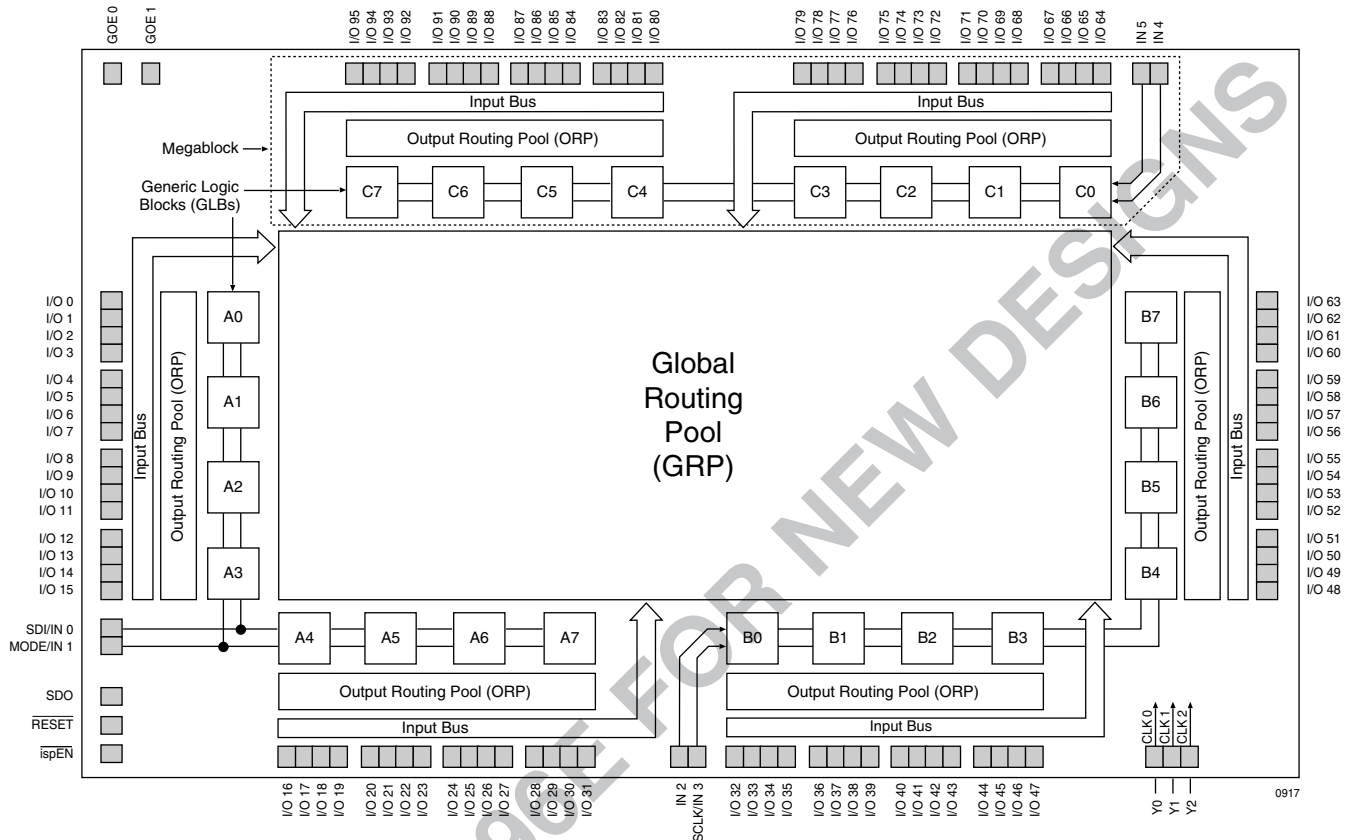

The devices also have 96 I/O cells, each of which is directly connected to an I/O pin. Each I/O cell can be individually programmed to be a combinatorial input, output or bi-directional I/O pin with 3-state control. The signal levels are TTL compatible voltages and the output drivers can source 4 mA or sink 8 mA. Each output can be programmed independently for fast or slow output slew rate to minimize overall output switching noise.

Eight GLBs, 32 I/O cells, two dedicated inputs and two ORPs are connected together to make a Megablock (Figure 1). The outputs of the eight GLBs are connected to a set of 32 universal I/O cells by the two ORPs. Each ispLSI 2096 and 2096A device contains three Megablocks.

The GRP has as its inputs, the outputs from all of the GLBs and all of the inputs from the bi-directional I/O cells. All of these signals are made available to the inputs of the GLBs. Delays through the GRP have been equalized to minimize timing skew.

Clocks in the ispLSI 2096 and 2096A devices are selected using the dedicated clock pins. Three dedicated clock pins (Y0, Y1, Y2) or an asynchronous clock can be selected on a GLB basis. The asynchronous or Product Term clock can be generated in any GLB for its own clock.

Absolute Maximum Ratings ¹

Supply Voltage V_{CC} -0.5 to +7.0V
 Input Voltage Applied -2.5 to $V_{CC} + 1.0V$
 Off-State Output Voltage Applied -2.5 to $V_{CC} + 1.0V$
 Storage Temperature -65 to 150°C
 Case Temp. with Power Applied -55 to 125°C
 Max. Junction Temp. (T_J) with Power Applied ... 150°C

1. Stresses above those listed under the “Absolute Maximum Ratings” may cause permanent damage to the device. Functional operation of the device at these or at any other conditions above those indicated in the operational sections of this specification is not implied (while programming, follow the programming specifications).

DC Recommended Operating Condition

SYMBOL	PARAMETER	MIN.	MAX.	UNITS	
V_{CC}	Supply Voltage	Commercial $T_A = 0^\circ\text{C to } +70^\circ\text{C}$	4.75	5.25	V
		Industrial $T_A = -40^\circ\text{C to } +85^\circ\text{C}$	4.5	5.5	V
V_{IL}	Input Low Voltage	0	0.8	V	
V_{IH}	Input High Voltage	2.0	$V_{CC} + 1$	V	

Table 2 - 0005/2096

Capacitance ($T_A = 25^\circ\text{C}$, $f = 1.0\text{ MHz}$)

SYMBOL	PARAMETER	TYPICAL	UNITS	TEST CONDITIONS
C_1	I/O and Dedicated Input Capacitance	8	pf	$V_{CC} = 5.0V$, $V_{I/O, IN} = 2.0V$
C_2	Clock Capacitance	15	pf	$V_{CC} = 5.0V$, $V_Y = 2.0V$

Table 2-0006a

Data Retention Specifications

PARAMETER	MINIMUM	MAXIMUM	UNITS
Data Retention	20	–	Years
Erase/Reprogram Cycles	10000	–	Cycles

Table 2-0008A-isp

Switching Test Conditions

Input Pulse Levels	GND to 3.0V	
Input Rise and Fall Time 10% to 90%	-125	≤ 2 ns
	Others	≤ 3 ns
Input Timing Reference Levels	1.5V	
Output Timing Reference Levels	1.5V	
Output Load	See Figure 2	

3-state levels are measured 0.5V from steady-state active level.

Table 2-0003/2096

Figure 2. Test Load

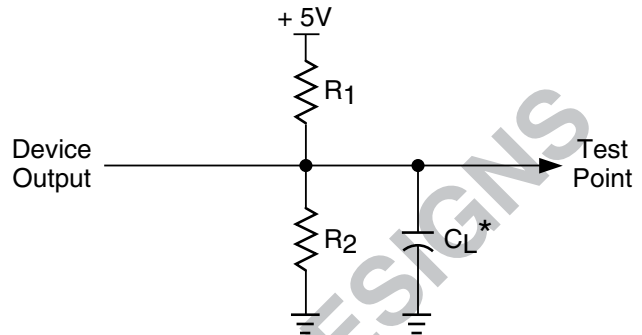

*CL includes Test Fixture and Probe Capacitance.

0213/2096

Output Load Conditions (see Figure 2)

TEST CONDITION		R1	R2	CL
A		470Ω	390Ω	35pF
B	Active High	∞	390Ω	35pF
	Active Low	470Ω	390Ω	35pF
C	Active High to Z at $V_{OH}-0.5V$	∞	390Ω	5pF
	Active Low to Z at $V_{OL}+0.5V$	470Ω	390Ω	5pF

Table 2-0004/2096

DC Electrical Characteristics

Over Recommended Operating Conditions

SYMBOL	PARAMETER	CONDITION	MIN.	TYP. ³	MAX.	UNITS	
V_{OL}	Output Low Voltage	$I_{OL} = 8 \text{ mA}$	-	-	0.4	V	
V_{OH}	Output High Voltage	$I_{OH} = -4 \text{ mA}$	2.4	-	-	V	
I_{IL}	Input or I/O Low Leakage Current	$0V \leq V_{IN} \leq V_{IL} \text{ (Max.)}$	-	-	-10	μA	
I_{IH}	Input or I/O High Leakage Current	$3.5V \leq V_{IN} \leq V_{CC}$	-	-	10	μA	
I_{IL-isp}	ispEN Input Low Leakage Current	$0V \leq V_{IN} \leq V_{IL} \text{ (Max.)}$	-	-	-150	μA	
I_{IL-PU}	I/O Active Pull-Up Current	$0V \leq V_{IN} \leq V_{IL}$	-	-	-150	μA	
I_{OS}¹	Output Short Circuit Current	$V_{CC} = 5V, V_{OUT} = 0.5V$	-	-	-200	mA	
I_{CC}^{2,4}	Operating Power Supply Current	$V_{IL} = 0.0V, V_{IH} = 3.0V$ $f_{CLOCK} = 1 \text{ MHz}$	Commercial	-	150	295	mA
		Industrial	-	150	-	mA	

Table 2-0007/2096

- One output at a time for a maximum duration of one second. $V_{OUT} = 0.5V$ was selected to avoid test problems by tester ground degradation. Characterized but not 100% tested.
- Measured using six 16-bit counters.
- Typical values are at $V_{CC} = 5V$ and $T_A = 25^\circ C$.
- Maximum I_{CC} varies widely with specific device configuration and operating frequency. Refer to the Power Consumption section of this data sheet and the Thermal Management section of the Lattice Semiconductor Data Book or CD-ROM to estimate maximum I_{CC} .

External Timing Parameters

Over Recommended Operating Conditions

PARAMETER	TEST COND. ⁴	# ²	DESCRIPTION ¹	-125		-100		-80		UNITS
				MIN.	MAX.	MIN.	MAX.	MIN.	MAX.	
t_{pd1}	A	1	Data Propagation Delay, 4PT Bypass, ORP Bypass	–	7.5	–	10.0	–	15.0	ns
t_{pd2}	A	2	Data Propagation Delay	–	10.0	–	13.0	–	18.5	ns
f_{max}	A	3	Clock Frequency with Internal Feedback ³	125	–	100	–	81.0	–	MHz
f_{max} (Ext.)	–	4	Clock Frequency with External Feedback ($\frac{1}{t_{su2} + t_{co1}}$)	100	–	77.0	–	57.0	–	MHz
f_{max} (Tog.)	–	5	Clock Frequency, Max. Toggle	125	–	100	–	83.0	–	MHz
t_{su1}	–	6	GLB Reg. Setup Time before Clock, 4 PT Bypass	5.0	–	6.5	–	9.0	–	ns
t_{co1}	A	7	GLB Reg. Clock to Output Delay, ORP Bypass	–	4.0	–	5.0	–	6.5	ns
t_{h1}	–	8	GLB Reg. Hold Time after Clock, 4 PT Bypass	0.0	–	0.0	–	0.0	–	ns
t_{su2}	–	9	GLB Reg. Setup Time before Clock	6.0	–	8.0	–	11.0	–	ns
t_{co2}	–	10	GLB Reg. Clock to Output Delay	–	4.5	–	6.0	–	8.0	ns
t_{h2}	–	11	GLB Reg. Hold Time after Clock	0.0	–	0.0	–	0.0	–	ns
t_{r1}	A	12	Ext. Reset Pin to Output Delay	–	10.0	–	13.5	–	17.0	ns
t_{rw1}	–	13	Ext. Reset Pulse Duration	5.0	–	6.5	–	10.0	–	ns
t_{p_{to}een}	B	14	Product Term OE, Enable	–	12.0	–	15.0	–	18.0	ns
t_{p_{to}edis}	C	15	Product Term OE, Disable	–	12.0	–	15.0	–	18.0	ns
t_{g_{oe}een}	B	16	Global OE, Enable	–	7.0	–	9.0	–	12.0	ns
t_{g_{oe}edis}	C	17	Global OE, Disable	–	7.0	–	9.0	–	12.0	ns
t_{wh}	–	18	External Synchronous Clock Pulse Duration, High	4.0	–	5.0	–	6.0	–	ns
t_{wl}	–	19	External Synchronous Clock Pulse Duration, Low	4.0	–	5.0	–	6.0	–	ns

Table 2-0030/2096

1. Unless noted otherwise, all parameters use the GRP, 20 PTXOR path, ORP and Y0 clock.
2. Refer to Timing Model in this data sheet for further details.
3. Standard 16-bit counter using GRP feedback.
4. Reference Switching Test Conditions section.

Internal Timing Parameters¹

Over Recommended Operating Conditions

PARAMETER	# ²	DESCRIPTION	-125		-100		-80		UNITS
			MIN.	MAX.	MIN.	MAX.	MIN.	MAX.	
Inputs									
t_{io}	20	Input Buffer Delay	–	0.2	–	0.5	–	1.8	ns
t_{din}	21	Dedicated Input Delay	–	1.5	–	2.2	–	4.4	ns
GRP									
t_{grp}	22	GRP Delay	–	1.3	–	1.7	–	2.6	ns
GLB									
t_{4ptbpc}	23	4 Product Term Bypass Comb. Path Delay	–	4.5	–	5.8	–	8.1	ns
t_{4ptbpr}	24	4 Product Term Bypass Reg. Path Delay	–	5.0	–	5.8	–	6.8	ns
t_{1ptxor}	25	1 Product Term/XOR Path Delay	–	5.7	–	6.8	–	8.0	ns
t_{20ptxor}	26	20 Product Term/XOR Path Delay	–	6.0	–	7.3	–	8.8	ns
t_{xoradj}	27	XOR Adjacent Path Delay ³	–	6.5	–	8.0	–	9.8	ns
t_{gbp}	28	GLB Register Bypass Delay	–	0.5	–	0.5	–	1.3	ns
t_{gsu}	29	GLB Register Setup Time before Clock	0.8	–	1.2	–	1.4	–	ns
t_{gh}	30	GLB Register Hold Time after Clock	3.0	–	4.0	–	6.0	–	ns
t_{gco}	31	GLB Register Clock to Output Delay	–	0.2	–	0.3	–	0.4	ns
t_{gro}	32	GLB Register Reset to Output Delay	–	1.1	–	1.3	–	1.6	ns
t_{ptre}	33	GLB Product Term Reset to Register Delay	–	4.8	–	6.1	–	8.6	ns
t_{ptoe}	34	GLB Product Term Output Enable to I/O Cell Delay	–	7.3	–	8.6	–	9.0	ns
t_{ptck}	35	GLB Product Term Clock Delay	3.3	5.6	4.1	7.1	5.6	10.2	ns
ORP									
t_{orp}	36	ORP Delay	–	0.8	–	1.4	–	2.0	ns
t_{orpbp}	37	ORP Bypass Delay	–	0.3	–	0.4	–	0.5	ns
Outputs									
t_{ob}	38	Output Buffer Delay	–	1.2	–	1.6	–	2.0	ns
t_{sl}	39	Output Slew Limited Delay Adder	–	10.0	–	10.0	–	10.0	ns
t_{oen}	40	I/O Cell OE to Output Enabled	–	3.2	–	4.2	–	4.6	ns
t_{odis}	41	I/O Cell OE to Output Disabled	–	3.2	–	4.2	–	4.6	ns
t_{goe}	42	Global Output Enable	–	3.8	–	4.8	–	7.4	ns
Clocks									
t_{gy0}	43	Clock Delay, Y0 to Global GLB Clock Line (Ref. Clock)	2.3	2.3	2.7	2.7	3.6	3.6	ns
t_{gy1/2}	44	Clock Delay, Y1 or Y2 to Global GLB Clock Line	2.3	2.3	2.7	2.7	3.6	3.6	ns
Global Reset									
t_{gr}	45	Global Reset to GLB	–	6.9	–	9.2	–	11.4	ns

Table 2-0036/2096

- Internal Timing Parameters are not tested and are for reference only.
- Refer to Timing Model in this data sheet for further details.
- The XOR adjacent path can only be used by hard macros.

ispLSI 2096/A Timing Model

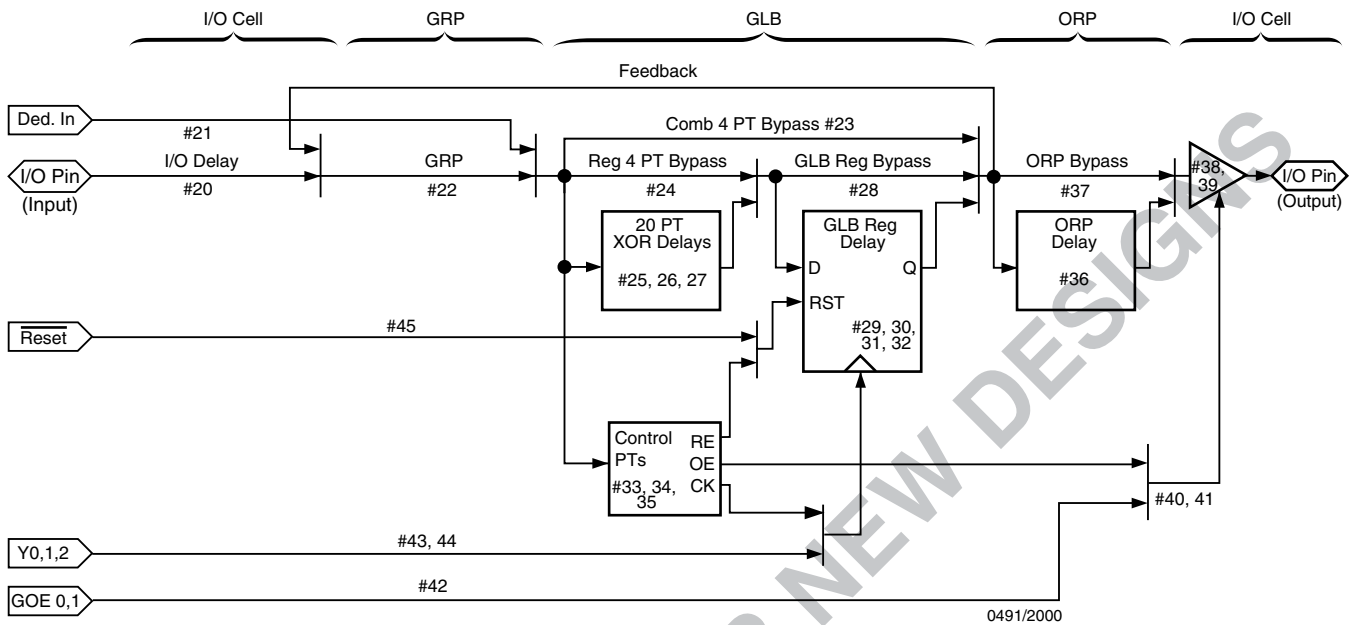

Derivations of t_{su} , t_h and t_{co} from the Product Term Clock

$$\begin{aligned}
 t_{su} &= \text{Logic} + \text{Reg } s_u - \text{Clock (min)} \\
 &= (t_{io} + t_{grp} + t_{20ptxor}) + (t_{gsu}) - (t_{io} + t_{grp} + t_{ptck(min)}) \\
 &= (\#20 + \#22 + \#26) + (\#29) - (\#20 + \#22 + \#35) \\
 3.5 \text{ ns} &= (0.2 + 1.3 + 6.0) + (0.8) - (0.2 + 1.3 + 3.3) \\
 \\
 t_h &= \text{Clock (max)} + \text{Reg } h - \text{Logic} \\
 &= (t_{io} + t_{grp} + t_{ptck(max)}) + (t_{gh}) - (t_{io} + t_{grp} + t_{20ptxor}) \\
 &= (\#20 + \#22 + \#35) + (\#30) - (\#20 + \#22 + \#26) \\
 2.6 \text{ ns} &= (0.2 + 1.3 + 5.6) + (3.0) - (0.2 + 1.3 + 6.0) \\
 \\
 t_{co} &= \text{Clock (max)} + \text{Reg } c_o + \text{Output} \\
 &= (t_{io} + t_{grp} + t_{ptck(max)}) + (t_{gco}) + (t_{orp} + t_{ob}) \\
 &= (\#20 + \#22 + \#35) + (\#31) + (\#36 + \#38) \\
 9.3 \text{ ns} &= (0.2 + 1.3 + 5.6) + (0.2) + (0.8 + 1.2)
 \end{aligned}$$

Note: Calculations are based upon timing specifications for the ispLSI 2096/A-125L.

Table 2-0042B/2096

Power Consumption

Power consumption in the ispLSI 2096 and 2096A devices depends on two primary factors: the speed at which the device is operating and the number of Product Terms

used. Figure 4 shows the relationship between power and operating speed.

Figure 4. Typical Device Power Consumption vs fmax

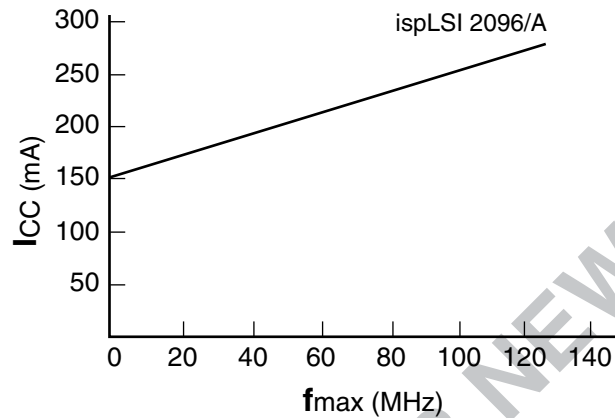

Notes: Configuration of six 16-bit counters
Typical current at 5V, 25°C

ICC can be estimated for the ispLSI 2096/A using the following equation:

$$I_{CC}(\text{mA}) = 20 + (\# \text{ of PTs} * 0.67) + (\# \text{ of nets} * \text{Max freq} * 0.011)$$

Where:

- # of PTs = Number of Product Terms used in design
- # of nets = Number of Signals used in device
- Max freq = Highest Clock Frequency to the device (in MHz)

The ICC estimate is based on typical conditions (VCC = 5.0V, room temperature) and an assumption of two GLB loads on average exists. These values are for estimates only. Since the value of ICC is sensitive to operating conditions and the program in the device, the actual ICC should be verified.

0127/2096

Pin Description

NAME	PQFP & TQFP PIN NUMBERS	DESCRIPTION
I/O 0 - I/O 5 I/O 6 - I/O 11 I/O 12 - I/O 17 I/O 18 - I/O 23 I/O 24 - I/O 29 I/O 30 - I/O 35 I/O 36 - I/O 41 I/O 42 - I/O 47 I/O 48 - I/O 53 I/O 54 - I/O 59 I/O 60 - I/O 65 I/O 66 - I/O 71 I/O 72 - I/O 77 I/O 78 - I/O 83 I/O 84 - I/O 89 I/O 90 - I/O 95	21, 22, 23, 24, 25, 26 27, 28, 29, 30, 31, 32 34, 35, 36, 37, 38, 39 40, 41, 42, 43, 44, 45 52, 53, 54, 55, 56, 57 58, 59, 60, 61, 62, 63 66, 67, 68, 69, 70, 71 72, 73, 74, 75, 76, 77 85, 86, 87, 88, 89, 90 91, 92, 93, 94, 95, 96 98, 99, 100, 101, 102, 103 104, 105, 106, 107, 108, 109 117, 118, 119, 120, 121, 122 123, 124, 125, 126, 127, 128 2, 3, 4, 5, 6, 7 8, 9, 10, 11, 12, 13	Input/Output Pins - These are the general purpose I/O pins used by the logic array.
GOE 0, GOE 1	64, 114	Global Output Enables input pins.
IN 2, IN 4, IN 5	51, 84, 110	Dedicated input pins to the device.
$\overline{\text{ispEN}}$	18	Input - Dedicated in-system programming enable input pin. This pin is brought low to enable the programming mode. The MODE, SDI, SDO and SCLK options become active.
SDI/IN 0 ²	20	Input - This pin performs two functions. When $\overline{\text{ispEN}}$ is logic low, it functions as an input pin to load programming data into the device. SDI/IN0 also is used as one of the two control pins for the isp state machine. When $\overline{\text{ispEN}}$ is high, it functions as a dedicated input pin.
MODE/IN 1 ²	46	Input - This pin performs two functions. When $\overline{\text{ispEN}}$ is logic low, it functions as a pin to control the operation of the isp state machine. When $\overline{\text{ispEN}}$ is high, it functions as a dedicated input pin.
SDO	50	Output - When $\overline{\text{ispEN}}$ is logic low, it functions as an output pin to read serial shift register data.
SCLK/IN 3 ²	78	Input - This pin performs two functions. When $\overline{\text{ispEN}}$ is logic low, it functions as a clock pin for the Serial Shift Register. When $\overline{\text{ispEN}}$ is high, it functions as a dedicated input pin.
$\overline{\text{RESET}}$	19	Active Low (0) Reset pin which resets all of the GLB and I/O registers in the device.
Y0, Y1, Y2	15, 83, 80	Dedicated Clock input. This clock input is connected to one of the clock inputs of all the GLBs on the device.
GND	1, 17, 33, 49, 65, 81, 97, 112	Ground (GND)
VCC	16, 48, 82, 113	VCC
NC ¹	14, 47, 79, 111, 115, 116	No Connect.

1. NC pins are not to be connected to any active signals, VCC or GND.
2. Pins have dual function capability.

Table 2-0002-2096

Part Number Description

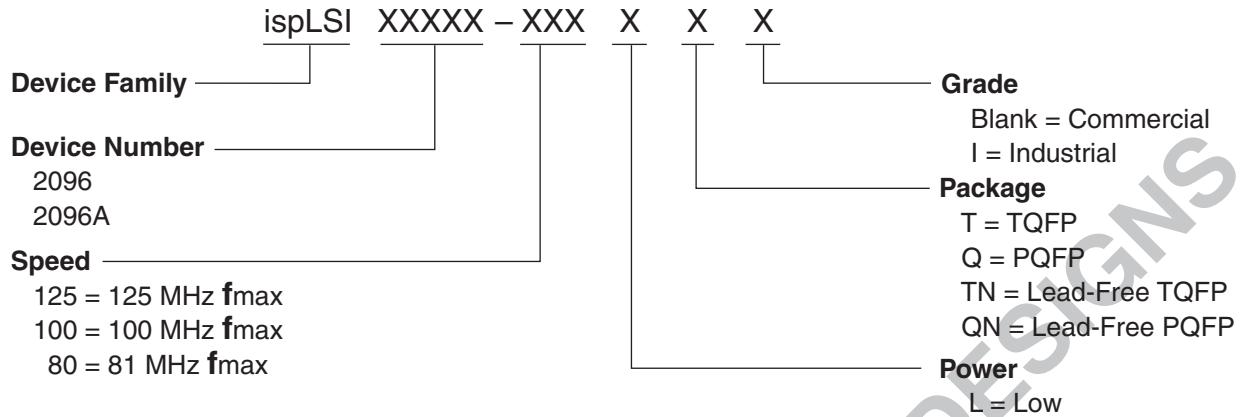

ispLSI 2096/A Ordering Information

Conventional Packaging

COMMERCIAL

FAMILY	f_{max} (MHz)	t_{pd} (ns)	ORDERING NUMBER	PACKAGE
ispLSI	125	7.5	ispLSI 2096A-125LQ128	128-Pin PQFP
	125	7.5	ispLSI 2096A-125LT128	128-Pin TQFP
	100	10	ispLSI 2096A-100LQ128	128-Pin PQFP
	100	10	ispLSI 2096A-100LT128	128-Pin TQFP
	81	15	ispLSI 2096A-80LQ128	128-Pin PQFP
	81	15	ispLSI 2096A-80LT128	128-Pin TQFP
	125	7.5	ispLSI 2096-125LQ	128-Pin PQFP
	125	7.5	ispLSI 2096-125LT	128-Pin TQFP
	100	10	ispLSI 2096-100LQ	128-Pin PQFP
	100	10	ispLSI 2096-100LT	128-Pin TQFP
	81	15	ispLSI 2096-80LQ	128-Pin PQFP
	81	15	ispLSI 2096-80LT	128-Pin TQFP

Table 2-0041B/2096

INDUSTRIAL

FAMILY	f_{max} (MHz)	t_{pd} (ns)	ORDERING NUMBER	PACKAGE
ispLSI	81	15	ispLSI 2096A-80LQ128I	128-Pin PQFP
	81	15	ispLSI 2096A-80LT128I	128-Pin TQFP
	81	15	ispLSI 2096-80LQI	128-Pin PQFP
	81	15	ispLSI 2096-80LTI	128-Pin TQFP

Table 2-0041D/2096

ispLSI 2096/A Ordering Information (Cont.)

Lead-Free Packaging

COMMERCIAL

FAMILY	fmax (MHz)	tpd (ns)	ORDERING NUMBER	PACKAGE
ispLSI	125	7.5	ispLSI 2096A-125LQN128	Lead-Free 128-Pin PQFP
	125	7.5	ispLSI 2096A-125LTN128	Lead-Free 128-Pin TQFP
	100	10	ispLSI 2096A-100LQN128	Lead-Free 128-Pin PQFP
	100	10	ispLSI 2096A-100LTN128	Lead-Free 128-Pin TQFP
	81	15	ispLSI 2096A-80LQN128	Lead-Free 128-Pin PQFP
	81	15	ispLSI 2096A-80LTN128	Lead-Free 128-Pin TQFP

INDUSTRIAL

FAMILY	fmax (MHz)	tpd (ns)	ORDERING NUMBER	PACKAGE
ispLSI	81	15	ispLSI 2096A-80LQN128I	Lead-Free 128-Pin PQFP
	81	15	ispLSI 2096A-80LTN128I	Lead-Free 128-Pin TQFP

Revision History

Date	Version	Change Summary
—	08	Previous Lattice release.
August 2006	09	Updated for lead-free package options.