

## VSC7147 and VSC7147-01 - Hex PBC with Dual Repeater/Retimer



### FEATURES:

- ▶ Industry's first IC with six Port Bypass Circuits (PBC) supporting both 1.0625Gb/s and 2.125Gb/s Fibre Channel data rates – Dual mode provides flexibility by having one device for new and legacy designs
- ▶ Two FibreTimer™ Cells configurable as:
  - Repeaters for low latency
  - Retimers for true Fibre Channel Compliance
  - Reduces external retimer components, provides design flexibility by allowing mixing and matching of the functions for design optimization
- ▶ Digital design of the FibreTimers produce a device that is well controlled over voltage, process and temperature variations Provides a more robust and reliable design
- ▶ User-selectable, on-chip receive termination at either 100Ω or 150Ω
- ▶ Speed independent Tx and Rx paths aid in Fibre Channel Auto-Speed Negotiation – Allows the device to migrate as the specification evolves
- ▶ Device can be strapped for 1 or 2Gb/s operation – Supports dual speed storage applications
- ▶ World-class signal integrity for jitter compliance – Reduces debug and redesign efforts
- ▶ Two digital Signal Detect Units to detect the presence of valid Fibre Channel encoded serial data - Improves signal detect reliability
- ▶ User selectable Pre-Emphasis on all high-speed outputs - distorts outputs signal for improved signal driving over long trace and cable distances
- ▶ 106.25MHz reference clock
- ▶ 5V-tolerant LVTTTL inputs – Provides design flexibility and backward compatibility
- ▶ Cable equalization on all high-speed inputs – Manages and corrects signal latency and distortion
- ▶ Single 2.5V supply - Reduces wiring complexity
- ▶ 100-pin, 14mm exposed pad TQFP package - Ideal for compact JBOD designs

### GENERAL DESCRIPTION:



The VSC7147 expands Vitesse's wide offering of Fibre Channel products with an IC for the growing 2.125Gb/s Fibre Channel storage market. The device features six Port Bypass Circuits (PBC) that support both 1.0625Gb/s and 2.125Gb/s Fibre Channel data rates. The

VSC7147 enables Fibre Channel Disk Arrays, JBODs (Just a Bunch of Disks) and storage subsystem equipment designers to integrate more ports and disk drives and maintain consistently high signal quality using fewer components.

In addition to the PBCs that steer serial Fibre Channel signals to disk drives and bypass faulty ports, the VSC7147 features dual FibreTimer Repeater/Retimer cells.

Each FibreTimer cell contains an all-digital clock recovery unit (CRU) that can be configured as either a Repeater or a Retimer. In the repeater mode, recovered data is retransmitted to a recovered clock, allowing for improved jitter attenuation and low latency. In the retimer mode, recovered data is re-transmitted synchronously to a local reference clock with no jitter transfer ensuring compliance to Fibre Channel signal quality specifications.

The VSC7147-01 adds an analog signal detect (ASD) function which helps the signal detection capabilities of the Fiber Timers™.

### VSC7147 APPLICATIONS:

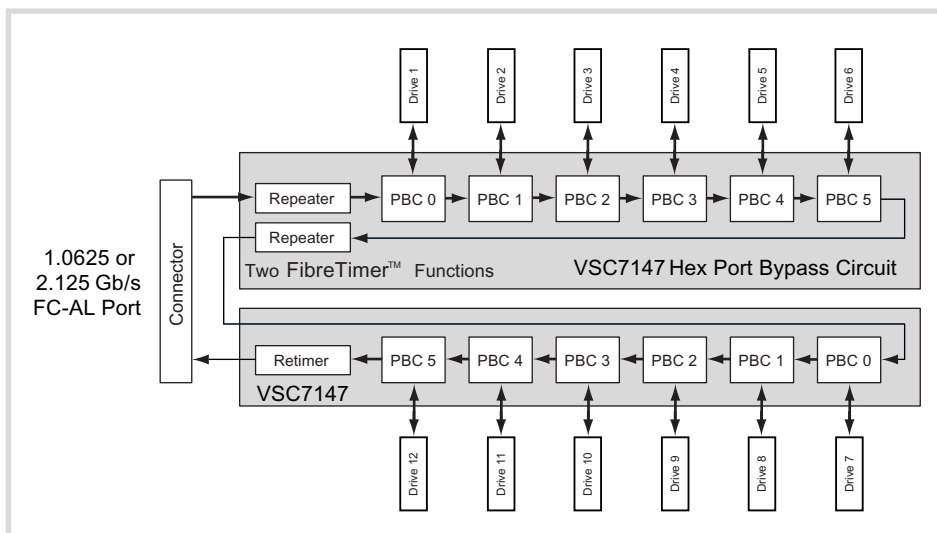

Several VSC7147's can be cascaded together to create a JBOD. The flexibility of the FibreTimers allow repeater and retimer functions to reside where they make the most sense for the backplane board design.

### Your Partner for Success.

For more information on Vitesse Products visit the Vitesse web site at [www.vitesse.com](http://www.vitesse.com) or contact Vitesse Sales at (800) VITESSE or [sales@vitesse.com](mailto:sales@vitesse.com)

## VITESSE

741 Calle Plano  
Camarillo, CA 93012  
Tel: 805.388.3700  
Fax: 805.388.7565  
[www.vitesse.com](http://www.vitesse.com)