



ST72334xx-Auto, ST72314xx-Auto, ST72124Jx-Auto

8-bit MCU for automotive with single voltage Flash/ROM memory, ADC, 16-bit timers, SPI, SCI interfaces

■ Memories

- 8 or 16 Kbyte Program memory (ROM or single voltage Flash) with readout protection and in-situ programming (remote ISP)
- 256 bytes EEPROM Data memory (with readout protection option in ROM devices)
- 384 or 512 bytes RAM

■ Clock, Reset and Supply Management

- Enhanced reset system
- Enhanced low voltage supply supervisor with 3 programmable levels
- Clock sources: crystal/ceramic resonator oscillators or RC oscillators, external clock, backup Clock Security System
- 4 Power Saving Modes: Halt, Active Halt, Wait and Slow
- Beep and clock-out capabilities

■ Interrupt Management

- 10 interrupt vectors plus TRAP and RESET
- 15 external interrupt lines (4 vectors)

■ 44 or 32 I/O Ports

- 44 or 32 multifunctional bidirectional I/O lines:
- 21 or 19 alternate function lines
- 12 or 8 high sink outputs

■ 4 Timers

- Configurable watchdog timer
- Real-time base
- Two 16-bit timers with: 2 input captures (only one on timer A), 2 output compares (only one on timer A), External clock input on timer A, PWM and Pulse generator modes

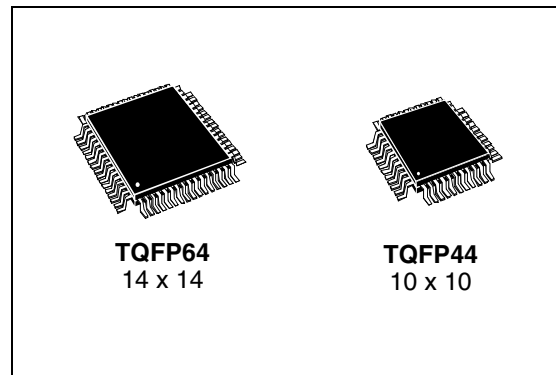

■ 2 Communications Interfaces

- SPI synchronous serial interface
- SCI asynchronous serial interface (LIN compatible)

■ 1 Analog Peripheral

- 8-bit ADC with 8 input channels (6 only on ST72334Jx, not available on ST72124J2)

■ Instruction Set

- 8-bit data manipulation
- 63 basic instructions
- 17 main addressing modes
- 8 x 8 unsigned multiply instruction
- True bit manipulation

■ Development Tools

- Full hardware/software development package

Device Summary

Features	ST72124J2 -Auto	ST72314J2 -Auto	ST72314J4 -Auto	ST72314N2 -Auto	ST72314N4 -Auto	ST72334J2 -Auto	ST72334J4 -Auto	ST72334N2 -Auto	ST72334N4 -Auto
Prog. memory	8 Kbytes		16 Kbytes	8 Kbytes	16 Kbytes	8 Kbytes	16 Kbytes	8 Kbytes	16 Kbytes
	Flash/ROM								
RAM (stack)	384 (256) bytes		512 (256) bytes	384 (256) bytes	512 (256) bytes	384 (256) bytes	512 (256) bytes	384 (256) bytes	512 (256) bytes
EEPROM			-	256 bytes					
Peripherals	Watchdog, Two 16-bit Timers, SPI, SCI								
	ADC								
Oper. Supply	3.2V to 5.5V								
CPU Freq.	Up to 8 MHz (with up to 16 MHz oscillator)								
Oper. Temp.	-40°C to +85°C / -40°C to +125°C Flash or ROM (-40°C to +105°C ROM only)								
Packages	TQFP44		TQFP64		TQFP44		TQFP64		

Rev. 1

October 2007

1/150

Table of Contents

1 PREAMBLE: ST72C334-Auto VERSUS ST72E331 SPECIFICATION	7
2 INTRODUCTION	8
3 PIN DESCRIPTION	9
4 REGISTER AND MEMORY MAP	14
5 FLASH PROGRAM MEMORY	18
5.1 INTRODUCTION	18
5.2 MAIN FEATURES	18
5.3 STRUCTURAL ORGANIZATION	18
5.4 IN-SITU PROGRAMMING (ISP) MODE	18
5.5 MEMORY READOUT PROTECTION	18
6 DATA EEPROM	19
6.1 INTRODUCTION	19
6.2 MAIN FEATURES	19
6.3 MEMORY ACCESS	20
6.4 POWER SAVING MODES	21
6.5 ACCESS ERROR HANDLING	21
6.6 REGISTER DESCRIPTION	22
6.7 READOUT PROTECTION OPTION	22
7 CENTRAL PROCESSING UNIT	23
7.1 INTRODUCTION	23
7.2 MAIN FEATURES	23
7.3 CPU REGISTERS	23
8 SUPPLY, RESET AND CLOCK MANAGEMENT	26
8.1 LOW VOLTAGE DETECTOR (LVD)	27
8.2 RESET SEQUENCE MANAGER (RSM)	28
8.2.1 Introduction	28
8.2.2 Asynchronous External RESET Pin	29
8.2.3 Internal Low Voltage Detection RESET	29
8.2.4 Internal Watchdog RESET	29
8.3 MULTI-OSCILLATOR (MO)	30
8.4 CLOCK SECURITY SYSTEM (CSS)	32
8.4.1 Clock Filter Control	32
8.4.2 Safe Oscillator Control	32
8.4.3 Low Power Modes	32
8.4.4 Interrupts	32
8.5 SUPPLY, RESET AND CLOCK REGISTER DESCRIPTION	33
9 INTERRUPTS	34
9.1 NON-MASKABLE SOFTWARE INTERRUPT	34
9.2 EXTERNAL INTERRUPTS	34
9.3 PERIPHERAL INTERRUPTS	34
10 POWER SAVING MODES	36
10.1 INTRODUCTION	36
10.2 SLOW MODE	36

Table of Contents

10.3	WAIT MODE	37
10.4	ACTIVE HALT AND HALT MODES	38
10.4.1	Active Halt Mode	38
10.4.2	Halt Mode	39
11	I/O PORTS	40
11.1	INTRODUCTION	40
11.2	FUNCTIONAL DESCRIPTION	40
11.2.1	Input Modes	40
11.2.2	Output Modes	40
11.2.3	Alternate Functions	40
11.3	I/O PORT IMPLEMENTATION	43
11.4	LOW POWER MODES	44
11.5	INTERRUPTS	44
11.5.1	Register Description	45
12	MISCELLANEOUS REGISTERS	47
12.1	I/O PORT INTERRUPT SENSITIVITY	47
12.2	I/O PORT ALTERNATE FUNCTIONS	47
12.3	REGISTERS DESCRIPTION	48
13	ON-CHIP PERIPHERALS	50
13.1	WATCHDOG TIMER (WDG)	50
13.1.1	Introduction	50
13.1.2	Main Features	50
13.1.3	Functional Description	50
13.1.4	Hardware Watchdog Option	51
13.1.5	Low Power Modes	51
13.1.6	Interrupts	51
13.1.7	Register Description	51
13.2	MAIN CLOCK CONTROLLER WITH REAL-TIME CLOCK TIMER (MCC/RTC)	53
13.2.1	Programmable CPU clock prescaler	53
13.2.2	Clock-out capability	53
13.2.3	Real-time clock timer (RTC)	53
13.2.4	Low Power Modes	54
13.2.5	Interrupts	54
13.3	16-BIT TIMER	55
13.3.1	Introduction	55
13.3.2	Main Features	55
13.3.3	Functional Description	55
13.3.4	Low Power Modes	67
13.3.5	Interrupts	67
13.3.6	Summary of Timer modes	67
13.3.7	Register Description	68
13.4	SERIAL PERIPHERAL INTERFACE (SPI)	73
13.4.1	Introduction	73
13.4.2	Main Features	73
13.4.3	General description	73
13.4.4	Functional Description	75

13.4.5	Low Power Modes	82
13.4.6	Interrupts	82
13.4.7	Register Description	83
13.5	SERIAL COMMUNICATIONS INTERFACE (SCI)	86
13.5.1	Introduction	86
13.5.2	Main Features	86
13.5.3	General Description	86
13.5.4	LIN Protocol support	86
13.5.5	Functional Description	88
13.5.6	Low Power Modes	93
13.5.7	Interrupts	93
13.5.8	Register Description	94
13.6	8-BIT A/D CONVERTER (ADC)	98
13.6.1	Introduction	98
13.6.2	Main Features	98
13.6.3	Functional Description	98
13.6.4	Low Power Modes	99
13.6.5	Interrupts	99
13.6.6	Register Description	100
14	INSTRUCTION SET	102
14.1	ST7 ADDRESSING MODES	102
14.1.1	Inherent	103
14.1.2	Immediate	103
14.1.3	Direct	103
14.1.4	Indexed (No Offset, Short, Long)	103
14.1.5	Indirect (Short, Long)	103
14.1.6	Indirect Indexed (Short, Long)	104
14.1.7	Relative Mode (Direct, Indirect)	104
14.2	INSTRUCTION GROUPS	105
15	ELECTRICAL CHARACTERISTICS	108
15.1	PARAMETER CONDITIONS	108
15.1.1	Minimum and Maximum values	108
15.1.2	Typical values	108
15.1.3	Typical curves	108
15.1.4	Loading capacitor	108
15.1.5	Pin input voltage	108
15.2	ABSOLUTE MAXIMUM RATINGS	109
15.2.1	Voltage Characteristics	109
15.2.2	Current Characteristics	109
15.2.3	Thermal Characteristics	110
15.3	OPERATING CONDITIONS	111
15.3.1	General Operating Conditions	111
15.3.2	Operating Conditions with Low Voltage Detector (LVD)	112
15.4	SUPPLY CURRENT CHARACTERISTICS	114
15.4.1	Run and Slow Modes	114
15.4.2	Wait and Slow Wait Modes	115
15.4.3	Halt and Active Halt Modes	116

15.4.4	Supply and Clock Managers	116
15.4.5	On-Chip Peripherals	116
15.5	CLOCK AND TIMING CHARACTERISTICS	117
15.5.1	General Timings	117
15.5.2	External Clock Source	117
15.5.3	Crystal and Ceramic Resonator Oscillators	118
15.5.4	RC Oscillators	121
15.5.5	Clock Security System (CSS)	122
15.6	MEMORY CHARACTERISTICS	123
15.6.1	RAM and Hardware Registers	123
15.6.2	EEPROM Data Memory	123
15.6.3	Flash Program Memory	123
15.7	EMC CHARACTERISTICS	124
15.7.1	Functional EMS	124
15.7.2	Absolute Electrical Sensitivity	125
15.7.3	ESD Pin Protection Strategy	127
15.8	I/O PORT PIN CHARACTERISTICS	129
15.8.1	General Characteristics	129
15.8.2	Output Driving Current	130
15.9	CONTROL PIN CHARACTERISTICS	132
15.9.1	Asynchronous RESET Pin	132
15.9.2	ISPSEL Pin	134
15.10	TIMER PERIPHERAL CHARACTERISTICS	135
15.10.1	Watchdog Timer	135
15.10.2	16-Bit Timer	135
15.11	COMMUNICATION INTERFACE CHARACTERISTICS	136
15.11.1	SPI - Serial Peripheral Interface	136
15.11.2	SCI - Serial Communications Interface	138
15.12	8-BIT ADC CHARACTERISTICS	139
16	PACKAGE CHARACTERISTICS	141
16.1	PACKAGE MECHANICAL DATA	141
16.2	THERMAL CHARACTERISTICS	142
16.3	ECOPACK®	142
17	DEVICE CONFIGURATION AND ORDERING INFORMATION	143
17.1	INTRODUCTION	143
17.2	OPTION BYTES	143
17.2.1	User Option Byte 0	143
17.2.2	User Option Byte 1	143
17.3	TRANSFER OF CUSTOMER CODE	144
17.4	DEVELOPMENT TOOLS	146
17.4.1	Suggested List of Socket Types	147
17.5	ST7 APPLICATION NOTES	147
18	IMPORTANT NOTES	148
18.1	SCI BAUD RATE REGISTERS	148
19	SUMMARY OF CHANGES	149

To obtain the most recent version of this datasheet,
please check at www.st.com>products>technical literature>datasheet.
Please also pay special attention to the Section ["IMPORTANT NOTES" on page 148](#)

1 PREAMBLE: ST72C334-Auto VERSUS ST72E331 SPECIFICATION

New Features available on the ST72C334-Auto

- 8 or 16K Flash/ROM with In-Situ Programming and Readout protection
- New ADC with a better accuracy and conversion time
- New configurable Clock, Reset and Supply system
- New power saving mode with real-time base: Active Halt
- Beep capability on PF1
- New interrupt source: Clock security system (CSS) or Main clock controller (MCC)

ST72C334-Auto I/O Configuration and Pinout

- Same pinout as ST72E331
- PA6 and PA7 are true open drain I/O ports without pull-up (same as ST72E331)
- PA3, PB3, PB4 and PF2 have no pull-up configuration (all I/Os present on TQFP44)
- PA5:4, PC3:2, PE7:4 and PF7:6 have high sink capabilities (20mA on N-buffer, 2mA on P-buffer and pull-up). On the ST72E331, all these pads (except PA5:4) were 2mA push-pull pads without high sink capabilities. PA4 and PA5 were 20mA true open drains.

New Memory Locations in ST72C334-Auto

- 20h: MISCR register becomes MISCR1 register (naming change)
- 29h: new control/status register for the MCC module
- 2Bh: new control/status register for the Clock, Reset and Supply control. This register replaces the WDGSR register keeping the WDOGF flag compatibility.
- 40h: new MISCR2 register

2 INTRODUCTION

The ST72334J/N-Auto, ST72314J/N-Auto and ST72124J-Auto devices are members of the ST7 microcontroller family. They can be grouped as follows:

- ST72334J/N-Auto devices are designed for mid-range applications with Data EEPROM, ADC, SPI and SCI interface capabilities.
- ST72314J/N-Auto devices target the same range of applications but without Data EEPROM.
- ST72124J-Auto devices are for applications that do not need Data EEPROM and the ADC peripheral.

All devices are based on a common industry-standard 8-bit core, featuring an enhanced instruction set.

The ST72C334J/N-Auto, ST72C314J/N-Auto and ST72C124J-Auto versions feature single-voltage

Flash memory with byte-by-byte In-Situ Programming (ISP) capability.

Under software control, all devices can be placed in Wait, Slow, Active Halt or Halt mode, reducing power consumption when the application is in idle or standby state.

The enhanced instruction set and addressing modes of the ST7 offer both power and flexibility to software developers, enabling the design of highly efficient and compact application code. In addition to standard 8-bit data management, all ST7 microcontrollers feature true bit manipulation, 8x8 unsigned multiplication and indirect addressing modes.

For easy reference, all parametric data is located in [Section 15 on page 108](#).

Figure 1. General Block Diagram

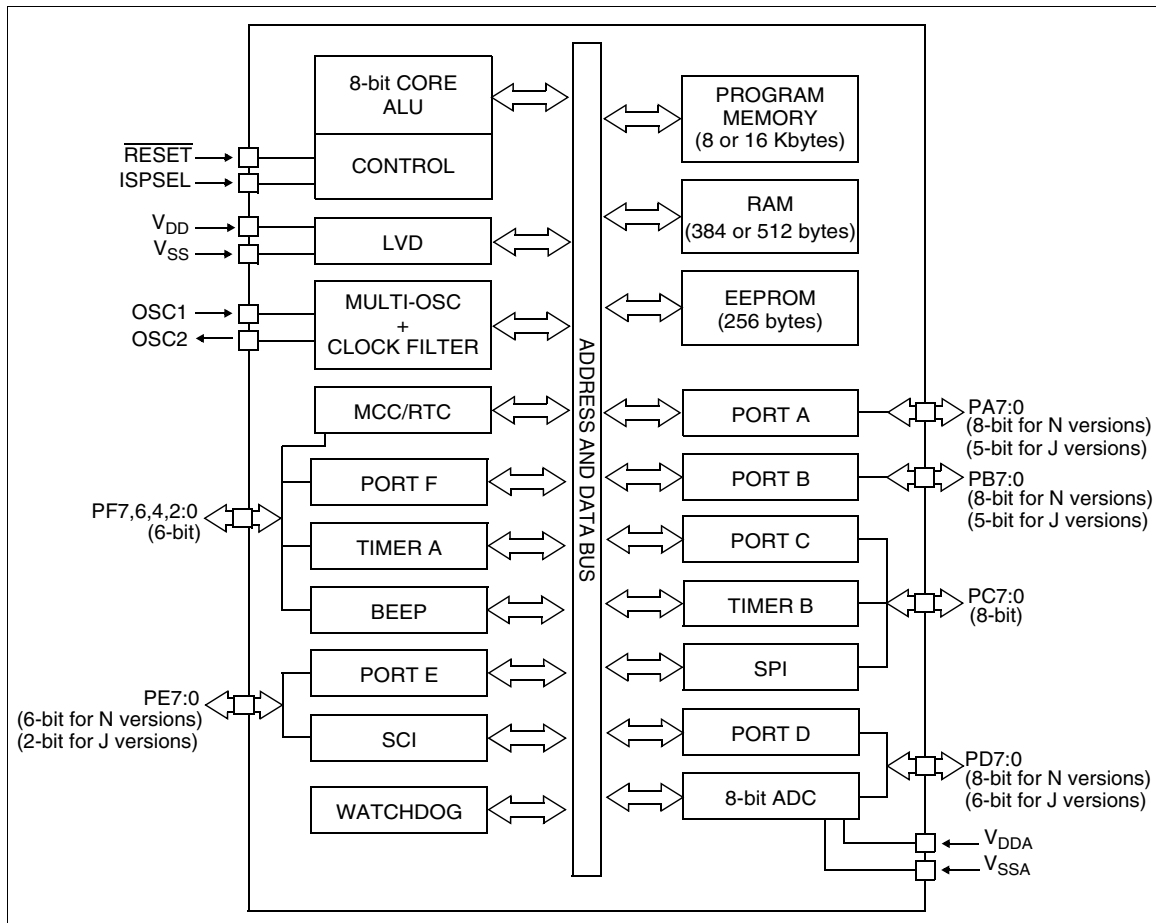

3 PIN DESCRIPTION

Figure 2. 64-Pin TQFP Package Pinout (N versions)

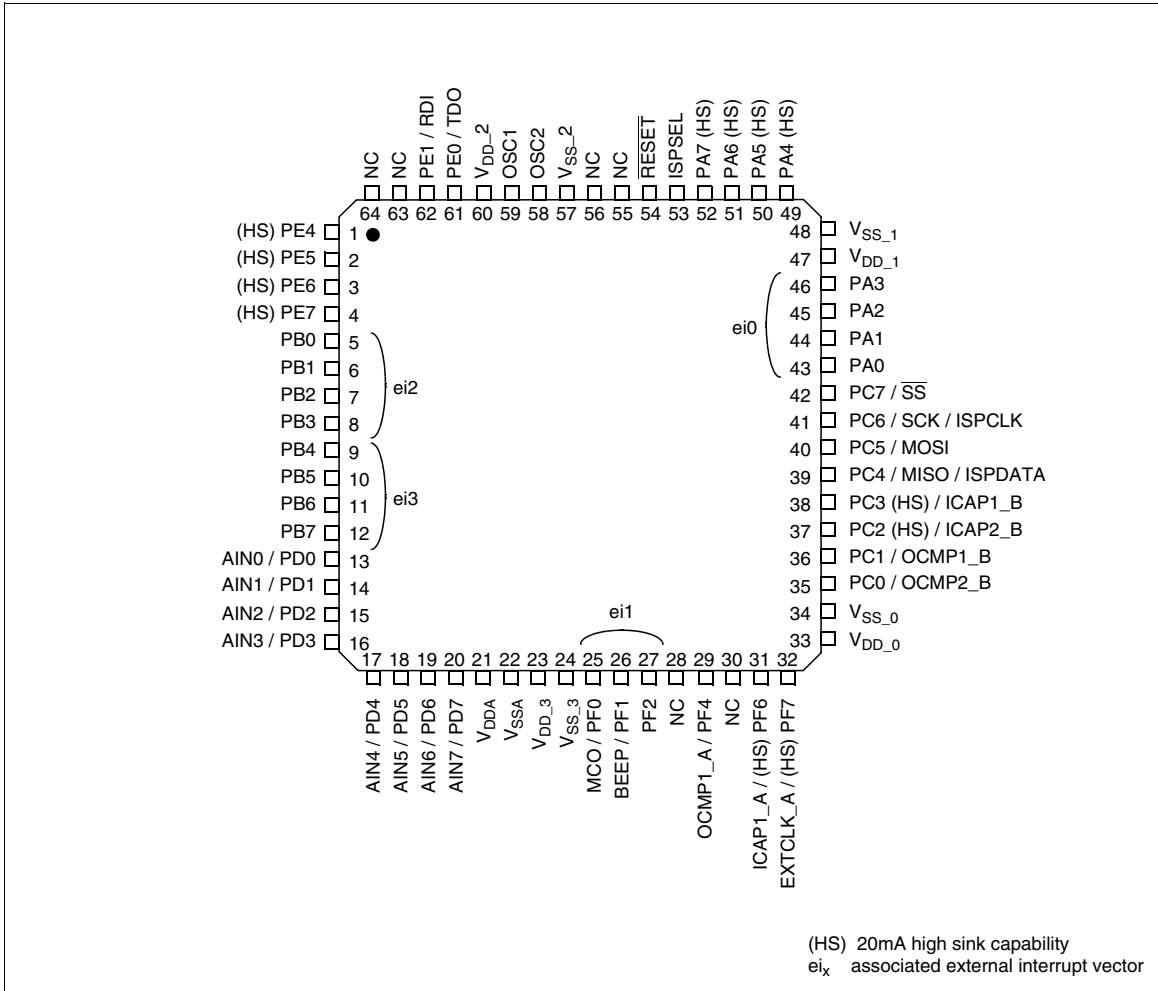

PIN DESCRIPTION (Cont'd)

Figure 3. 44-Pin TQFP Package Pinout (J versions)

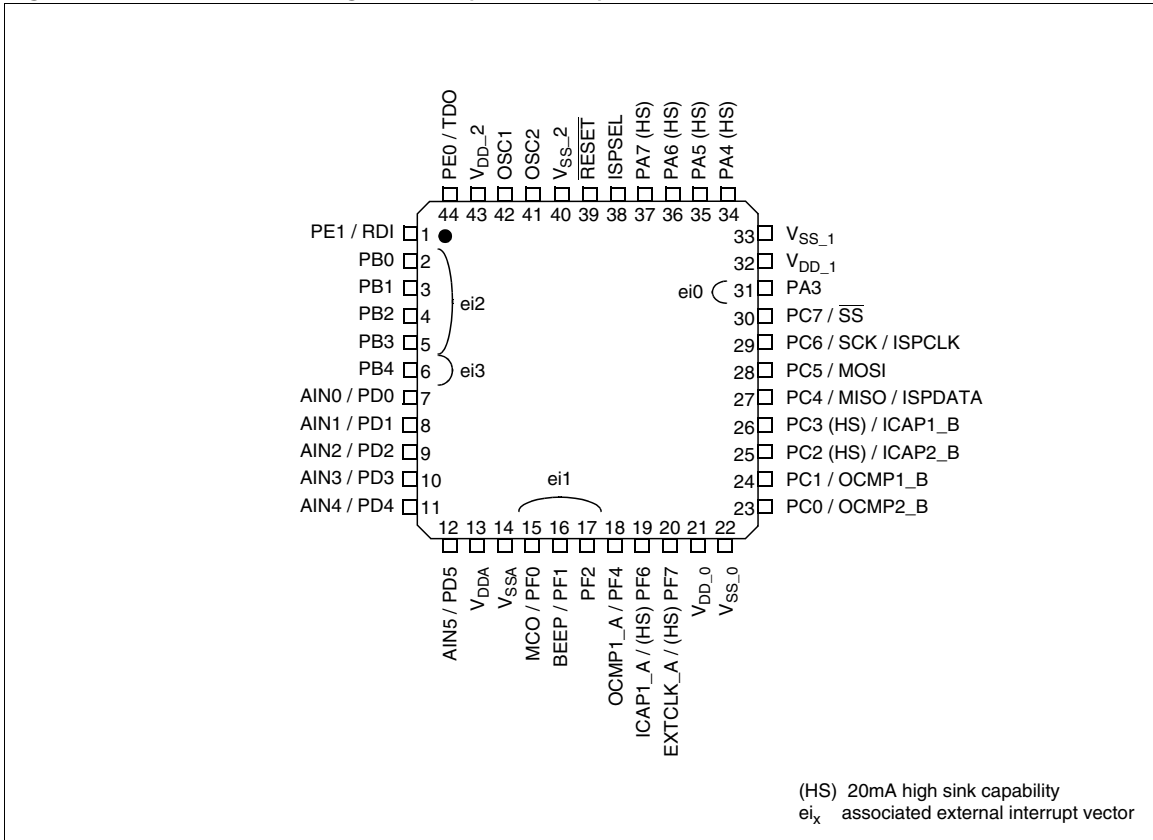

PIN DESCRIPTION (Cont'd)

For external pin connection guidelines, refer to [Section 15 "ELECTRICAL CHARACTERISTICS"](#) on page 108.

Legend / Abbreviations for Table 1:

Type: I = input, O = output, S = supply

Input level: A = Dedicated analog input

In/Output level: C = CMOS 0.3V_{DD}/0.7V_{DD},
C_T= CMOS 0.3V_{DD}/0.7V_{DD} with input trigger

Output level: HS = 20mA high sink (on N-buffer only)

Port and control configuration:

- Input: float = floating, wpu = weak pull-up, int = interrupt ¹⁾, ana = analog
- Output: OD = open drain ²⁾, PP = push-pull

Refer to [Section 11 "I/O PORTS"](#) on page 40 for more details on the software configuration of the I/O ports.

The RESET configuration of each pin is shown in bold. This configuration is valid as long as the device is in reset state.

Table 1. Device Pin Description

Pin No.	Pin Name	Type	Level		Port						Main function (after reset)	Alternate function
			Input	Output	Input				Output			
					float	wpu	int	ana	OD	PP		
1	- PE4 (HS)	I/O	C _T	HS	X	X			X	X	Port E4	
2	- PE5 (HS)	I/O	C _T	HS	X	X			X	X	Port E5	
3	- PE6 (HS)	I/O	C _T	HS	X	X			X	X	Port E6	
4	- PE7 (HS)	I/O	C _T	HS	X	X			X	X	Port E7	
5	2 PB0	I/O	C _T		X		ei2		X	X	Port B0	
6	3 PB1	I/O	C _T		X		ei2		X	X	Port B1	
7	4 PB2	I/O	C _T		X		ei2		X	X	Port B2	
8	5 PB3	I/O	C _T		X		ei2		X	X	Port B3	
9	6 PB4	I/O	C _T		X		ei3		X	X	Port B4	
10	- PB5	I/O	C _T		X		ei3		X	X	Port B5	
11	- PB6	I/O	C _T		X		ei3		X	X	Port B6	
12	- PB7	I/O	C _T		X		ei3		X	X	Port B7	
13	7 PD0/AIN0	I/O	C _T		X	X			X	X	Port D0	ADC Analog Input 0
14	8 PD1/AIN1	I/O	C _T		X	X			X	X	Port D1	ADC Analog Input 1
15	9 PD2/AIN2	I/O	C _T		X	X			X	X	Port D2	ADC Analog Input 2
16	10 PD3/AIN3	I/O	C _T		X	X			X	X	Port D3	ADC Analog Input 3
17	11 PD4/AIN4	I/O	C _T		X	X			X	X	Port D4	ADC Analog Input 4
18	12 PD5/AIN5	I/O	C _T		X	X			X	X	Port D5	ADC Analog Input 5
19	- PD6/AIN6	I/O	C _T		X	X			X	X	Port D6	ADC Analog Input 6
20	- PD7/AIN7	I/O	C _T		X	X			X	X	Port D7	ADC Analog Input 7
21	13 V _{DDA}	S										Analog Power Supply Voltage
22	14 V _{SSA}	S										Analog Ground Voltage
23	- V _{DD_3}	S										Digital Main Supply Voltage



ST72334xx-Auto, ST72314xx-Auto, ST72124Jx-Auto

Pin No.	Pin Name	Type	Level		Port						Main function (after reset)	Alternate function	
			Input	Output	Input				Output				
					float	wpu	int	ana	OD	PP			
24	- V _{SS_3}	S										Digital Ground Voltage	
25	15 PF0/MCO	I/O	C _T		X		ei1			X	X	Port F0	Main clock output (f _{OSC} /2)
26	16 PF1/BEEP	I/O	C _T		X		ei1			X	X	Port F1	Beep signal output
27	17 PF2	I/O	C _T		X			ei1		X	X	Port F2	
28	- NC											Not Connected	
29	18 PF4/OCMP1_A	I/O	C _T		X	X				X	X	Port F4	Timer A Output Compare 1
30	- NC											Not Connected	
31	19 PF6 (HS)/ICAP1_A	I/O	C _T	HS	X	X				X	X	Port F6	Timer A Input Capture 1
32	20 PF7 (HS)/EXTCLK_A	I/O	C _T	HS	X	X				X	X	Port F7	Timer A External Clock Source
33	21 V _{DD_0}	S										Digital Main Supply Voltage	
34	22 V _{SS_0}	S										Digital Ground Voltage	
35	23 PC0/OCMP2_B	I/O	C _T		X	X				X	X	Port C0	Timer B Output Compare 2
36	24 PC1/OCMP1_B	I/O	C _T		X	X				X	X	Port C1	Timer B Output Compare 1
37	25 PC2 (HS)/ICAP2_B	I/O	C _T	HS	X	X				X	X	Port C2	Timer B Input Capture 2
38	26 PC3 (HS)/ICAP1_B	I/O	C _T	HS	X	X				X	X	Port C3	Timer B Input Capture 1
39	27 PC4/MISO	I/O	C _T		X	X				X	X	Port C4	SPI Master In / Slave Out Data
40	28 PC5/MOSI	I/O	C _T		X	X				X	X	Port C5	SPI Master Out / Slave In Data
41	29 PC6/SCK	I/O	C _T		X	X				X	X	Port C6	SPI Serial Clock
42	30 PC7/SS	I/O	C _T		X	X				X	X	Port C7	SPI Slave Select (active low)
43	- PA0	I/O	C _T		X		ei0			X	X	Port A0	
44	- PA1	I/O	C _T		X		ei0			X	X	Port A1	
45	- PA2	I/O	C _T		X		ei0			X	X	Port A2	
46	31 PA3	I/O	C _T		X			ei0		X	X	Port A3	
47	32 V _{DD_1}	S										Digital Main Supply Voltage	
48	33 V _{SS_1}	S										Digital Ground Voltage	
49	34 PA4 (HS)	I/O	C _T	HS	X	X				X	X	Port A4	
50	35 PA5 (HS)	I/O	C _T	HS	X	X				X	X	Port A5	
51	36 PA6 (HS)	I/O	C _T	HS	X					T		Port A6	
52	37 PA7 (HS)	I/O	C _T	HS	X					T		Port A7	
53	38 ISPSEL	I										Must be tied low in user mode. In programming mode when available, this pin acts as In-Situ Programming mode selection.	
54	39 RESET	I/O	C			X					X	Top priority non maskable interrupt (active low)	
55	- NC											Not Connected	
56	- NC											Not Connected	
57	40 V _{SS_3}	S										Digital Ground Voltage	
58	41 OSC2 ³⁾	O										Resonator oscillator inverter output or capacitor input for RC oscillator	
59	42 OSC1 ³⁾	I										External clock input or Resonator oscillator inverter input or resistor input for RC oscillator	
60	43 V _{DD_3}	S										Digital Main Supply Voltage	

Pin No.	Pin Name	Type	Level		Port						Main function (after reset)	Alternate function
			Input	Output	Input				Output			
					float	wpu	int	ana	OD	PP		
61	44	PE0/TDO	I/O	C _T	X	X			X	X	Port E0	SCI Transmit Data Out
62	1	PE1/RDI	I/O	C _T	X	X			X	X	Port E1	SCI Receive Data In
63	-	NC	Not Connected									
64	-	NC										

Notes:

1. In the interrupt input column, “ei_x” defines the associated external interrupt vector. If the weak pull-up column (wpu) is merged with the interrupt column (int), then the I/O configuration is pull-up interrupt input, else the configuration is floating interrupt input.
2. In the open drain output column, “T” defines a true open drain I/O (P-Buffer and protection diode to V_{DD} are not implemented). See [Section 11 "I/O PORTS" on page 40](#) and [Section 15.8 "I/O PORT PIN CHARACTERISTICS" on page 129](#) for more details.
3. OSC1 and OSC2 pins connect a crystal or ceramic resonator, an external RC, or an external source to the on-chip oscillator see [Section 3 "PIN DESCRIPTION" on page 9](#) and [Section 15.5 "CLOCK AND TIMING CHARACTERISTICS" on page 117](#) for more details.

4 REGISTER AND MEMORY MAP

As shown in the [Figure 4](#), the MCU is capable of addressing 64 Kbytes of memories and I/O registers.

The available memory locations consist of 128 bytes of register locations, 384 or 512 bytes of RAM, up to 256 bytes of data EEPROM and 4 or 8 Kbytes of user program memory. The RAM

space includes up to 256 bytes for the stack from 0100h to 01FFh.

The highest address bytes contain the user reset and interrupt vectors.

IMPORTANT: Memory locations marked as “Reserved” must never be accessed. Accessing a reserved area can have unpredictable effects on the device.

Figure 4. Memory Map

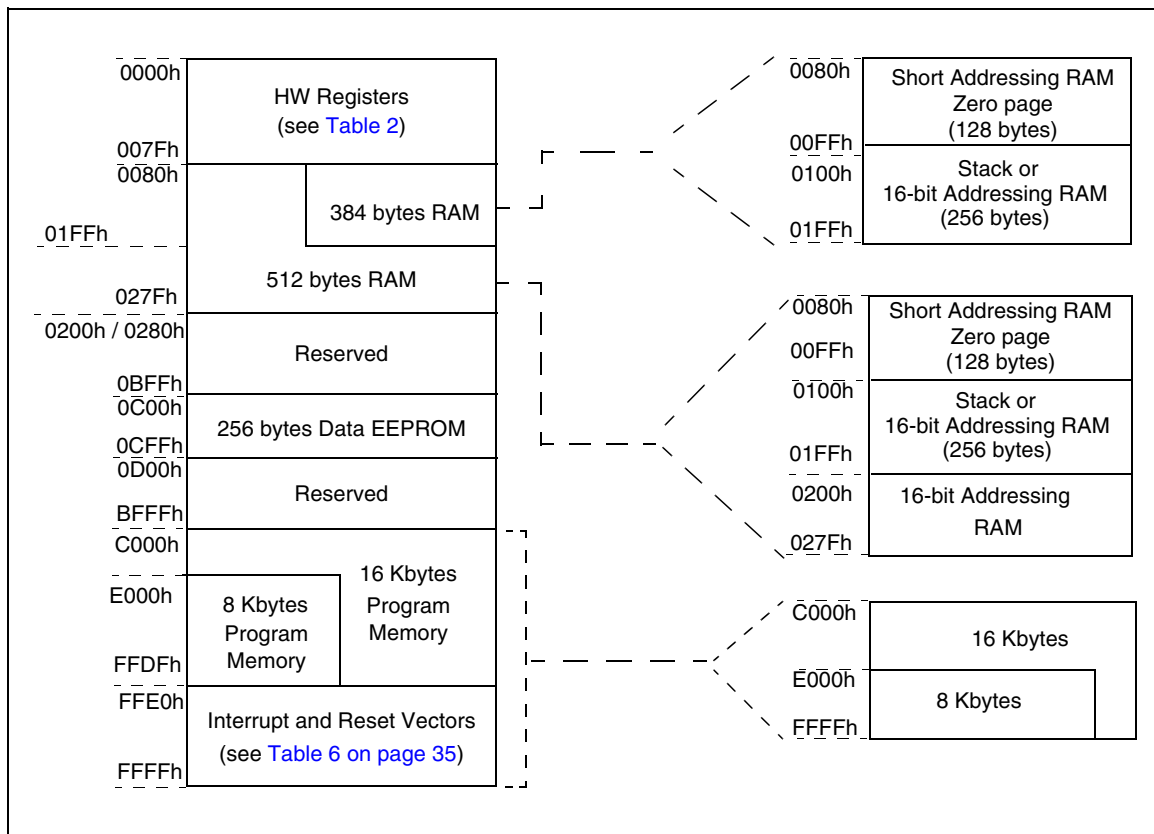

REGISTER AND MEMORY MAP (Cont'd)

Table 2. Hardware Register Map

Address	Block	Register Label	Register Name	Reset Status	Remarks
0000h 0001h 0002h	Port A	PADR PADDR PAOR	Port A Data Register Port A Data Direction Register Port A Option Register	00h ¹⁾ 00h 00h	R/W R/W R/W ²⁾
0003h	Reserved Area (1 byte)				
0004h 0005h 0006h	Port C	PCDR PCDDR PCOR	Port C Data Register Port C Data Direction Register Port C Option Register	00h ¹⁾ 00h 00h	R/W R/W R/W
0007h	Reserved Area (1 byte)				
0008h 0009h 000Ah	Port B	PBDR PBDDR PBOR	Port B Data Register Port B Data Direction Register Port B Option Register	00h ¹⁾ 00h 00h	R/W R/W R/W ²⁾
000Bh	Reserved Area (1 byte)				
000Ch 000Dh 000Eh	Port E	PEDR PEDDR PEOR	Port E Data Register Port E Data Direction Register Port E Option Register	00h ¹⁾ 00h 00h	R/W R/W R/W ²⁾
000Fh	Reserved Area (1 byte)				
0010h 0011h 0012h	Port D	PDDR PDDDR PDOR	Port D Data Register Port D Data Direction Register Port D Option Register	00h ¹⁾ 00h 00h	R/W R/W R/W ²⁾
0013h	Reserved Area (1 byte)				
0014h 0015h 0016h	Port F	PFDR PFDDR PFOR	Port F Data Register Port F Data Direction Register Port F Option Register	00h ¹⁾ 00h 00h	R/W R/W R/W
0017h to 001Fh	Reserved Area (9 bytes)				
0020h		MISCR1	Miscellaneous Register 1	00h	R/W
0021h 0022h 0023h	SPI	SPI DR SPI CR SPI SR	SPI Data I/O Register SPI Control Register SPI Status Register	xxh 0xh 00h	R/W R/W Read Only
0024h to 0028h	Reserved Area (5 bytes)				
0029h	MCC	MCCSR	Main Clock Control / Status Register	01h	R/W

ST72334xx-Auto, ST72314xx-Auto, ST72124Jx-Auto

Address	Block	Register Label	Register Name	Reset Status	Remarks
002Ah	WATCHDOG	WDGCR	Watchdog Control Register	7Fh	R/W
002Bh		CRSR	Clock, Reset, Supply Control / Status Register	000x 000x	R/W
002Ch	Data-EEPROM	EECSR	Data-EEPROM Control/Status Register	00h	R/W
002Dh 0030h	Reserved Area (4 bytes)				
0031h 0032h 0033h 0034h 0035h 0036h 0037h 0038h 0039h 003Ah 003Bh 003Ch 003Dh 003Eh 003Fh	TIMER A	TACR2 TACR1 TASR TAIC1HR TAIC1LR TAOC1HR TAOC1LR TACHR TACL TAACHR TAACLR TAIC2HR TAIC2LR TAOC2HR TAOC2LR	Timer A Control Register 2 Timer A Control Register 1 Timer A Status Register Timer A Input Capture 1 High Register Timer A Input Capture 1 Low Register Timer A Output Compare 1 High Register Timer A Output Compare 1 Low Register Timer A Counter High Register Timer A Counter Low Register Timer A Alternate Counter High Register Timer A Alternate Counter Low Register Timer A Input Capture 2 High Register Timer A Input Capture 2 Low Register Timer A Output Compare 2 High Register Timer A Output Compare 2 Low Register	00h 00h xxh xxh xxh 80h 00h FFh FCh FFh FCh xxh xxh 80h 00h	R/W R/W Read Only Read Only Read Only R/W R/W Read Only Read Only Read Only Read Only Read Only ³⁾ Read Only ³⁾ R/W ³⁾ R/W ³⁾
0040h		MISCR2	Miscellaneous Register 2	00h	R/W
0041h 0042h 0043h 0044h 0045h 0046h 0047h 0048h 0049h 004Ah 004Bh 004Ch 004Dh 004Eh 004Fh	TIMER B	TBCR2 TBCR1 TBRSR TBIC1HR TBIC1LR TBOC1HR TBOC1LR TBCHR TBCLR TBACHR TBACL TBIC2HR TBIC2LR TBOC2HR TBOC2LR	Timer B Control Register 2 Timer B Control Register 1 Timer B Status Register Timer B Input Capture 1 High Register Timer B Input Capture 1 Low Register Timer B Output Compare 1 High Register Timer B Output Compare 1 Low Register Timer B Counter High Register Timer B Counter Low Register Timer B Alternate Counter High Register Timer B Alternate Counter Low Register Timer B Input Capture 2 High Register Timer B Input Capture 2 Low Register Timer B Output Compare 2 High Register Timer B Output Compare 2 Low Register	00h 00h xxh xxh xxh 80h 00h FFh FCh FFh FCh xxh xxh 80h 00h	R/W R/W Read Only Read Only Read Only R/W R/W Read Only Read Only Read Only Read Only Read Only R/W R/W
0050h 0051h 0052h 0053h 0054h 0055h 0056h 0057h	SCI	SCISR SCIDR SCIBRR SCICR1 SCICR2 SCIERP SCIETPR	SCI Status Register SCI Data Register SCI Baud Rate Register SCI Control Register 1 SCI Control Register 2 SCI Extended Receive Prescaler Register Reserved area SCI Extended Transmit Prescaler Register	C0h xxh 00xx xxxx xxh 00h 00h ---	Read Only R/W R/W R/W R/W R/W ---
0058h 006Fh	Reserved Area (24 bytes)				

ST72334xx-Auto, ST72314xx-Auto, ST72124Jx-Auto

Address	Block	Register Label	Register Name	Reset Status	Remarks
0070h 0071h	ADC	ADCDR ADCCSR	Data Register Control/Status Register	xxh 00h	Read Only R/W
0072h to 007Fh	Reserved Area (14 bytes)				

Legend: x=undefined, R/W=read/write

Notes:

1. The contents of the I/O port DR registers are readable only in output configuration. In input configuration, the values of the I/O pins are returned instead of the DR register contents.
2. The bits corresponding to unavailable pins are forced to 1 by hardware, affecting accordingly the reset status value. These bits must always keep their reset value.
3. External pin not available.

5 FLASH PROGRAM MEMORY

5.1 INTRODUCTION

Flash devices have a single voltage non-volatile Flash memory that may be programmed in-situ (or plugged in a programming tool) on a byte-by-byte basis.

5.2 MAIN FEATURES

- Remote In-Situ Programming (ISP) mode
- Up to 16 bytes programmed in the same cycle
- MTP memory (Multiple Time Programmable)
- Readout memory protection against piracy

5.3 STRUCTURAL ORGANIZATION

The Flash program memory is organized in a single 8-bit wide memory block which can be used for storing both code and data constants.

The Flash program memory is mapped in the upper part of the ST7 addressing space and includes the reset and interrupt user vector area.

5.4 IN-SITU PROGRAMMING (ISP) MODE

The Flash program memory can be programmed using Remote ISP mode. This ISP mode allows the contents of the ST7 program memory to be updated using a standard ST7 programming tools after the device is mounted on the application board. This feature can be implemented with a minimum number of added components and board area impact.

An example Remote ISP hardware interface to the standard ST7 programming tool is described below. For more details on ISP programming, refer to the ST7 Programming Specification.

Remote ISP Overview

The Remote ISP mode is initiated by a specific sequence on the dedicated ISPSEL pin.

The Remote ISP is performed in three steps:

- Selection of the RAM execution mode
- Download of Remote ISP code in RAM
- Execution of Remote ISP code in RAM to program the user program into the Flash

Remote ISP hardware configuration

In Remote ISP mode, the ST7 has to be supplied with power (V_{DD} and V_{SS}) and a clock signal (oscillator and application crystal circuit for example).

This mode needs five signals (plus the V_{DD} signal if necessary) to be connected to the programming tool. This signals are:

- $\overline{\text{RESET}}$: device reset
- V_{SS} : device ground power supply
- ISPCLK: ISP output serial clock pin
- ISPDATA: ISP input serial data pin
- ISPSEL: Remote ISP mode selection. This pin must be connected to V_{SS} on the application board through a pull-down resistor.

If any of these pins are used for other purposes on the application, a serial resistor has to be implemented to avoid a conflict if the other device forces the signal level.

Figure 5 shows a typical hardware interface to a standard ST7 programming tool. For more details on the pin locations, refer to the device pinout description.

Figure 5. Typical Remote ISP Interface

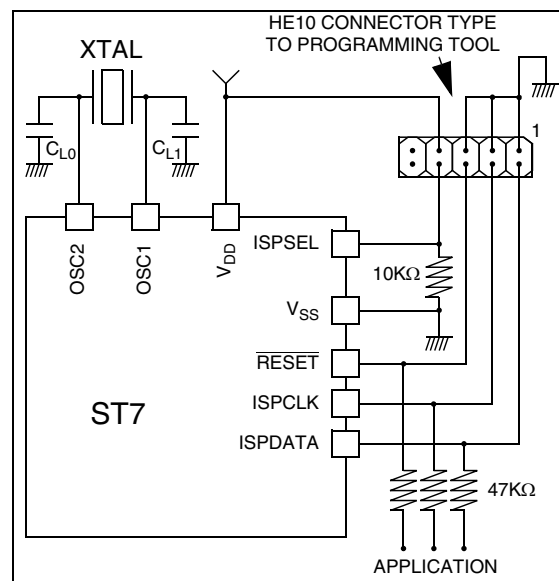

5.5 MEMORY READOUT PROTECTION

The readout protection is enabled through an option bit.

For Flash devices, when this option is selected, the program and data stored in the Flash memory are protected against readout piracy (including a re-write protection). When this protection option is removed the entire Flash program memory is first automatically erased. However, the EEPROM data memory (when available) can be protected only with ROM devices.

6 DATA EEPROM

6.1 INTRODUCTION

The Electrically Erasable Programmable Read Only Memory can be used as a non-volatile back-up for storing data. Using the EEPROM requires a basic access protocol described in this chapter.

6.2 MAIN FEATURES

- Up to 16 bytes programmed in the same cycle
- EEPROM mono-voltage (charge pump)
- Chained erase and programming cycles
- Internal control of the global programming cycle duration
- End of programming cycle interrupt flag
- Wait mode management

Figure 6. EEPROM Block Diagram

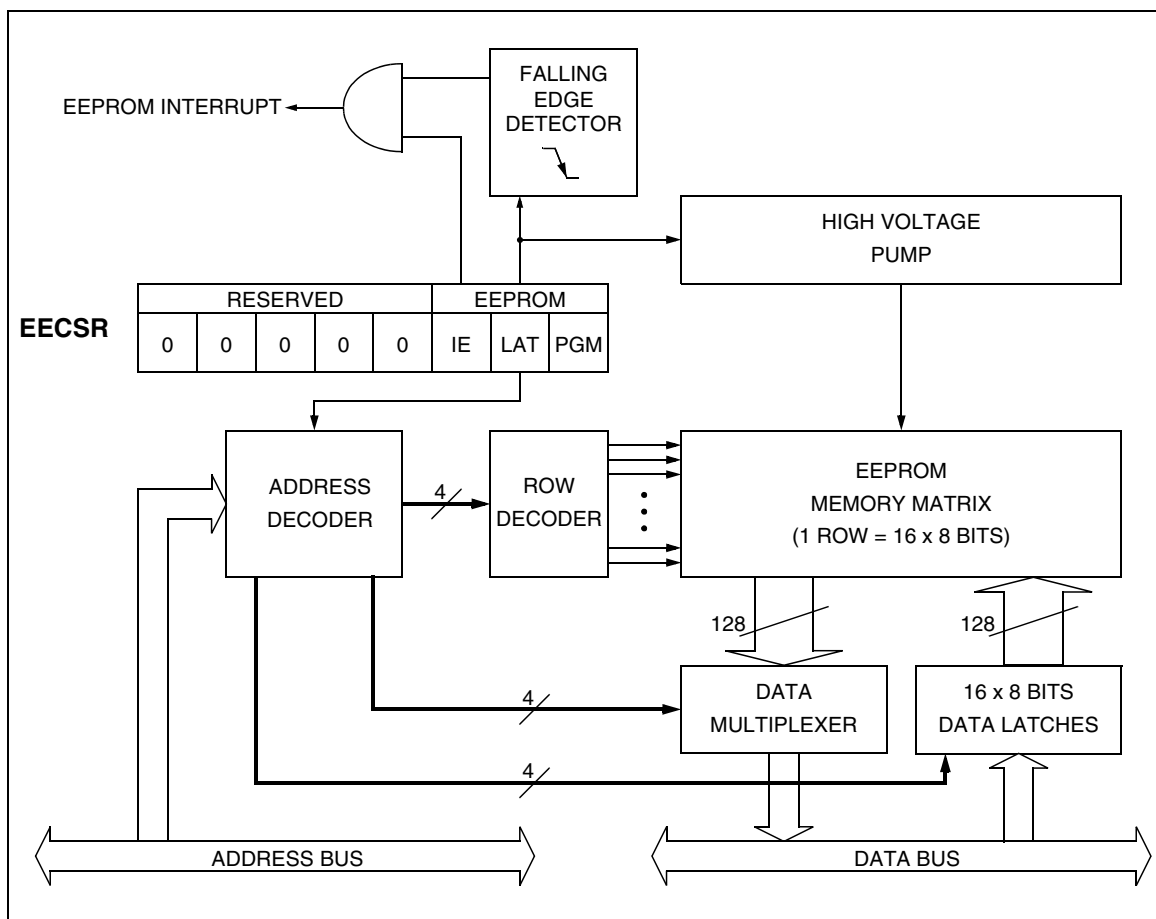

DATA EEPROM (Cont'd)

6.3 MEMORY ACCESS

The Data EEPROM memory read/write access modes are controlled by the LAT bit of the EEPROM Control/Status register (EECSR). The flowchart in Figure 7 describes these different memory access modes.

Read Operation (LAT=0)

The EEPROM can be read as a normal ROM location when the LAT bit of the EECSR register is cleared. In a read cycle, the byte to be accessed is put on the data bus in less than 1 CPU clock cycle. This means that reading data from EEPROM takes the same time as reading data from EPROM, but this memory cannot be used to execute machine code.

Write Operation (LAT=1)

To access the write mode, the LAT bit has to be set by software (the PGM bit remains cleared). When a write access to the EEPROM area occurs, the value is latched inside the 16 data latches according to its address.

When PGM bit is set by the software, all the previous bytes written in the data latches (up to 16) are programmed in the EEPROM cells. The effective high address (row) is determined by the last EEPROM write sequence. To avoid wrong programming, the user must take care that all the bytes written between two programming sequences have the same high address: only the four Least Significant Bits of the address can change.

At the end of the programming cycle, the PGM and LAT bits are cleared simultaneously, and an interrupt is generated if the IE bit is set. The Data EEPROM interrupt request is cleared by hardware when the Data EEPROM interrupt vector is fetched.

Note: Care should be taken during the programming cycle. Writing to the same memory location will over-program the memory (logical AND between the two write access data result) because the data latches are only cleared at the end of the programming cycle and by the falling edge of LAT bit.

It is not possible to read the latched data. This note is illustrated by the Figure 8.

Figure 7. Data EEPROM Programming Flowchart

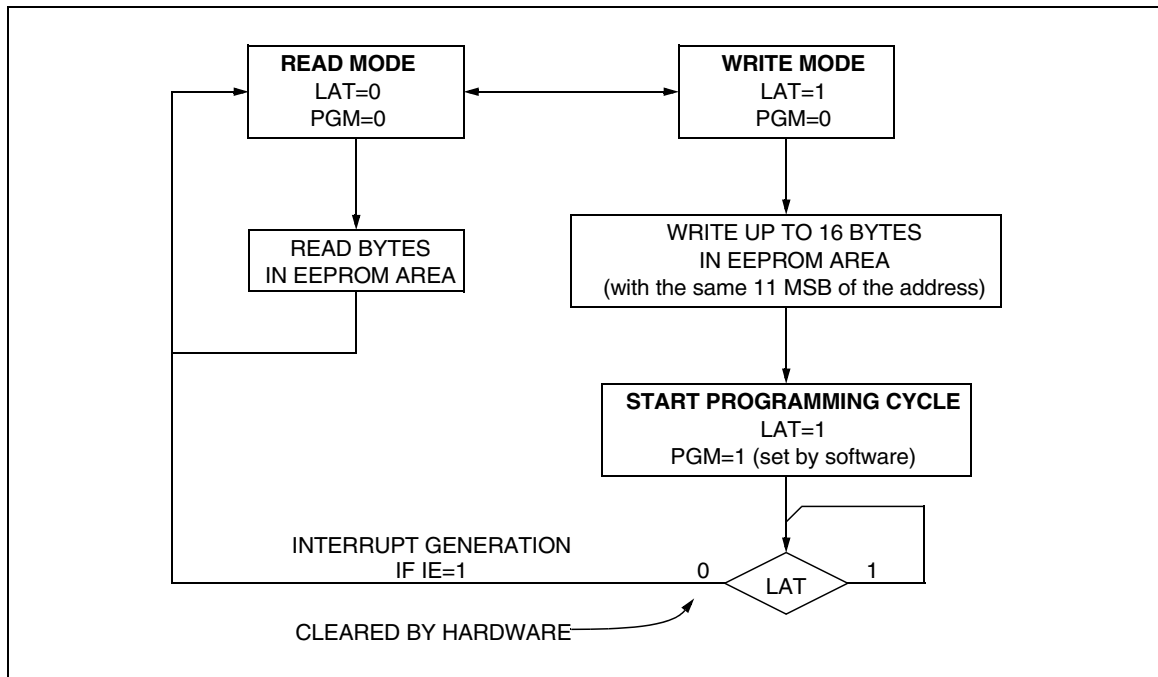

DATA EEPROM (Cont'd)

6.4 POWER SAVING MODES

Wait mode

The Data EEPROM can enter Wait mode on execution of the WFI instruction of the microcontroller. The Data EEPROM will immediately enter this mode if there is no programming in progress, otherwise the Data EEPROM will finish the cycle and then enter Wait mode.

Halt mode

The Data EEPROM immediately enters Halt mode if the microcontroller executes the HALT instruction. Therefore the EEPROM will stop the function in progress, and data may be corrupted.

6.5 ACCESS ERROR HANDLING

If a read access occurs while LAT=1, then the data bus will not be driven.

If a write access occurs while LAT=0, then the data on the bus will not be latched.

If a programming cycle is interrupted (by software/RESET action), the memory data will not be guaranteed.

Figure 8. Data EEPROM Programming Cycle

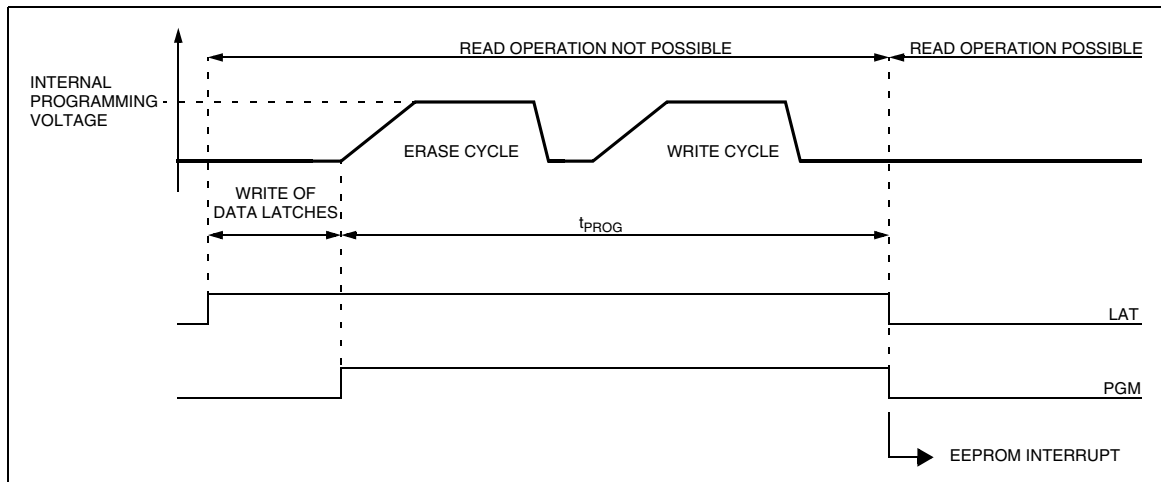

DATA EEPROM (Cont'd)

6.6 REGISTER DESCRIPTION

CONTROL/STATUS REGISTER (CSR)

Read/Write

Reset Value: 0000 0000 (00h)

7							0
0	0	0	0	0	IE	LAT	PGM

Bit 7:3 = Reserved, forced by hardware to 0.

Bit 2 = **IE** *Interrupt enable*

This bit is set and cleared by software. It enables the Data EEPROM interrupt capability when the PGM bit is cleared by hardware. The interrupt request is automatically cleared when the software enters the interrupt routine.

0: Interrupt disabled
1: Interrupt enabled

Bit 1 = **LAT** *Latch Access Transfer*

This bit is set by software. It is cleared by hardware at the end of the programming cycle. It can only be cleared by software if PGM bit is cleared.

0: Read mode
1: Write mode

Bit 0 = **PGM** *Programming control and status*

This bit is set by software to begin the programming cycle. At the end of the programming cycle, this bit is cleared by hardware and an interrupt is generated if the ITE bit is set.

0: Programming finished or not yet started
1: Programming cycle is in progress

Note: if the PGM bit is cleared during the programming cycle, the memory data is not guaranteed

Table 3. Data EEPROM Register Map and Reset Values

Address (Hex.)	Register Label	7	6	5	4	3	2	1	0
002Ch	EECSR Reset Value	0	0	0	0	0	IE 0	RWM 0	PGM 0

6.7 READOUT PROTECTION OPTION

The Data EEPROM can be optionally readout protected in ST72334 ROM devices (see option list on

[page 145](#)). ST72C334 Flash devices do not have this protection option.

7 CENTRAL PROCESSING UNIT

7.1 INTRODUCTION

This CPU has a full 8-bit architecture and contains six internal registers allowing efficient 8-bit data manipulation.

7.2 MAIN FEATURES

- 63 basic instructions
- Fast 8-bit by 8-bit multiply
- 17 main addressing modes
- Two 8-bit index registers
- 16-bit stack pointer
- Low power modes
- Maskable hardware interrupts
- Non-maskable software interrupt

7.3 CPU REGISTERS

The six CPU registers shown in [Figure 9](#) are not present in the memory mapping and are accessed by specific instructions.

Accumulator (A)

The Accumulator is an 8-bit general purpose register used to hold operands and the results of the arithmetic and logic calculations and to manipulate data.

Index Registers (X and Y)

In indexed addressing modes, these 8-bit registers are used to create either effective addresses or temporary storage areas for data manipulation. (The Cross-Assembler generates a precede instruction (PRE) to indicate that the following instruction refers to the Y register.)

The Y register is not affected by the interrupt automatic procedures (not pushed to and popped from the stack).

Program Counter (PC)

The program counter is a 16-bit register containing the address of the next instruction to be executed by the CPU. It is made of two 8-bit registers PCL (Program Counter Low which is the LSB) and PCH (Program Counter High which is the MSB).

Figure 9. CPU Registers

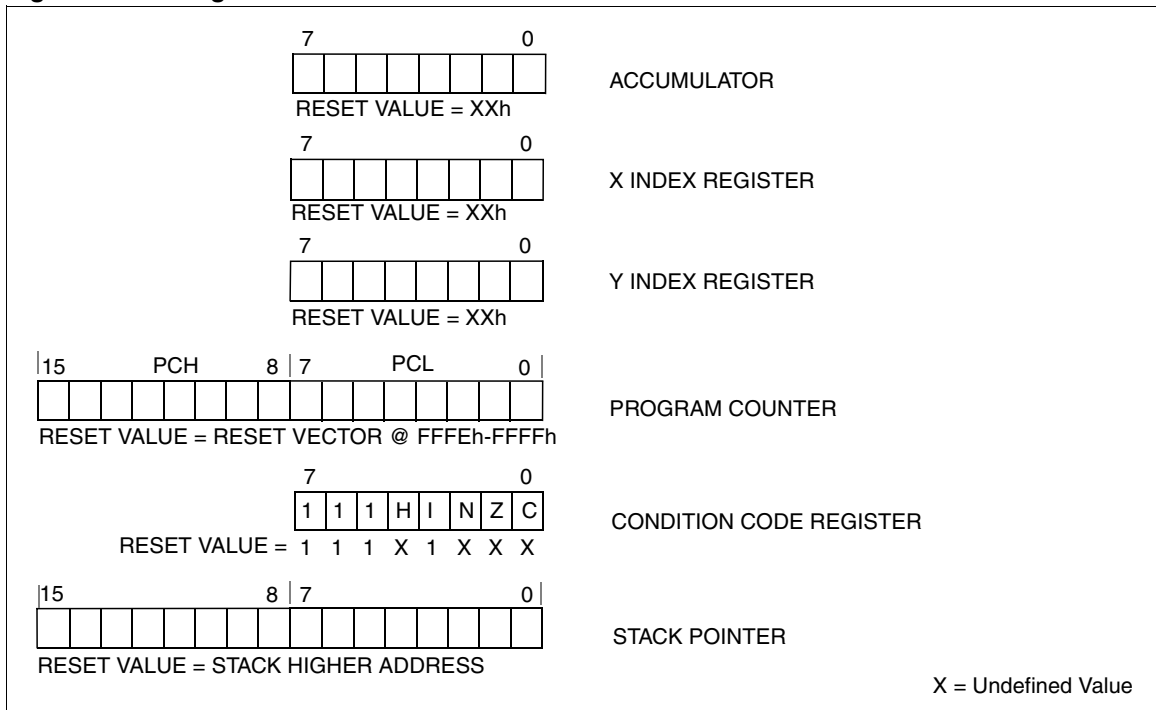

CPU REGISTERS (Cont'd)

CONDITION CODE REGISTER (CC)

Read/Write

Reset Value: 111x1xxx

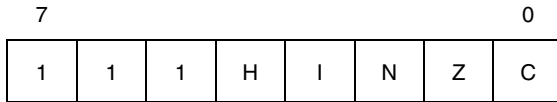

CENTRAL PROCESSING UNIT (Cont'd)

Stack Pointer (SP)

Read/Write

Reset Value: 01 FFh

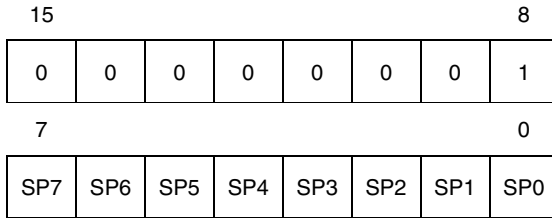

The Stack Pointer is a 16-bit register which is always pointing to the next free location in the stack. It is then decremented after data has been pushed onto the stack and incremented before data is popped from the stack (see Figure 10).

Since the stack is 256 bytes deep, the 8th most significant bits are forced by hardware. Following an MCU Reset, or after a Reset Stack Pointer instruction (RSP), the Stack Pointer contains its reset value (the SP7 to SP0 bits are set) which is the stack higher address.

The least significant byte of the Stack Pointer (called S) can be directly accessed by a LD instruction.

Note: When the lower limit is exceeded, the Stack Pointer wraps around to the stack upper limit, without indicating the stack overflow. The previously stored information is then overwritten and therefore lost. The stack also wraps in case of an underflow.

The stack is used to save the return address during a subroutine call and the CPU context during an interrupt. The user may also directly manipulate the stack by means of the PUSH and POP instructions. In the case of an interrupt, the PCL is stored at the first location pointed to by the SP. Then the other registers are stored in the next locations as shown in Figure 10.

- When an interrupt is received, the SP is decremented and the context is pushed on the stack.
- On return from interrupt, the SP is incremented and the context is popped from the stack.

A subroutine call occupies two locations and an interrupt five locations in the stack area.

Figure 10. Stack Manipulation Example

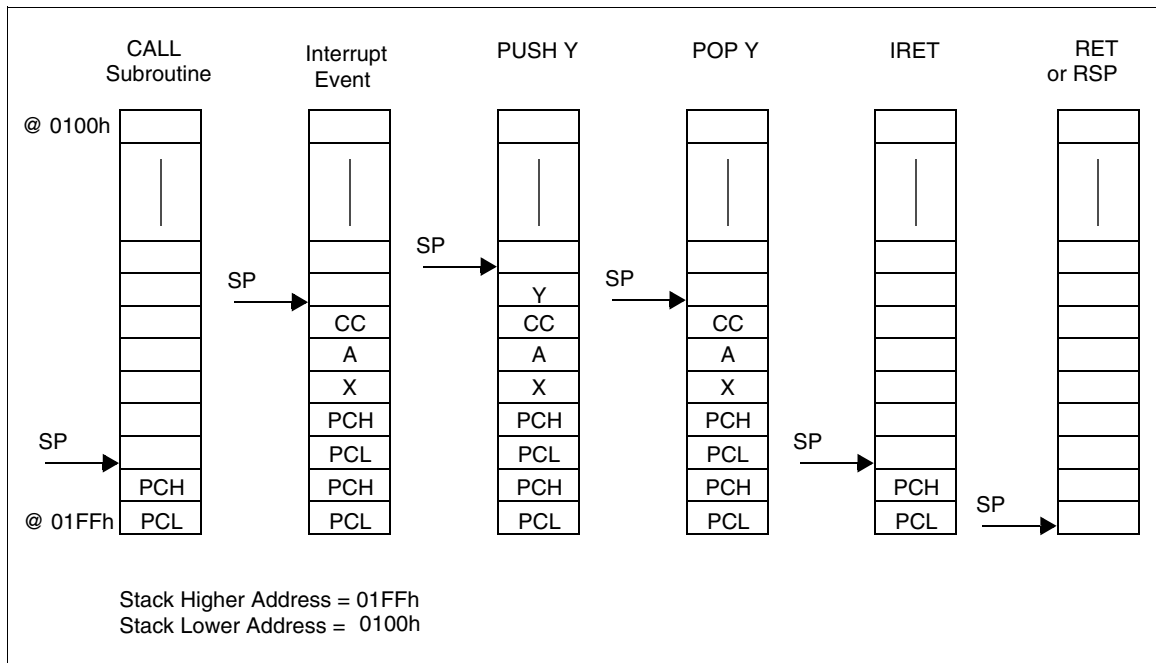

8 SUPPLY, RESET AND CLOCK MANAGEMENT

The ST72334J/N-Auto, ST72314J/N-Auto and ST72124J-Auto microcontrollers include a range of utility features for securing the application in critical situations (for example, in case of a power brown-out), and reducing the number of external components. An overview is shown in Figure 11.

See Section 15 "ELECTRICAL CHARACTERISTICS" on page 108 for more details.

- Multi-Oscillator (MO)
 - 4 Crystal/Ceramic resonator oscillators
 - 1 External RC oscillator
 - 1 Internal RC oscillator
- Clock Security System (CSS)
 - Clock Filter
 - Backup Safe Oscillator

Main Features

- Supply Manager with main supply low voltage detection (LVD)
- Reset Sequence Manager (RSM)

Figure 11. Clock, Reset and Supply Block Diagram

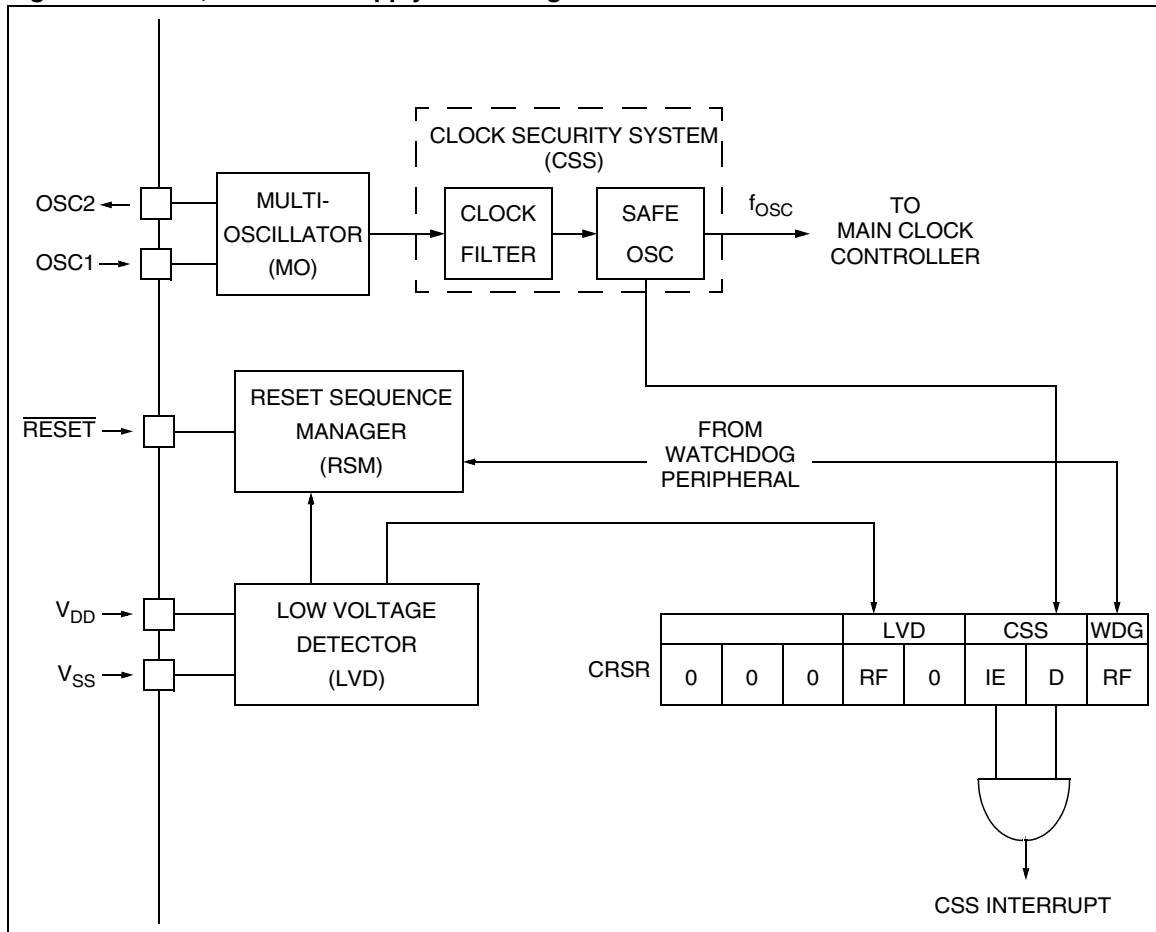

8.1 LOW VOLTAGE DETECTOR (LVD)

To allow the integration of power management features in the application, the Low Voltage Detector (LVD) generates a static reset when the V_{DD} supply voltage is below a V_{IT-} reference value. This means that it secures the power-up as well as the power-down keeping the ST7 in reset.

The V_{IT-} reference value for a voltage drop is lower than the V_{IT+} reference value for power-on in order to avoid a parasitic reset when the MCU starts running and sinks current on the supply (hysteresis).

The LVD Reset circuitry generates a reset when V_{DD} is below:

- V_{IT+} when V_{DD} is rising
- V_{IT-} when V_{DD} is falling

The LVD function is illustrated in the [Figure 12](#).

Provided the minimum V_{DD} value (guaranteed for the oscillator frequency) is above V_{IT-} , the MCU can only be in two modes:

- under full software control
- in static safe reset

In these conditions, secure operation is always ensured for the application without the need for external reset hardware.

During a Low Voltage Detector Reset, the $\overline{\text{RESET}}$ pin is held low, thus permitting the MCU to reset other devices.

Notes:

1. The LVD allows the device to be used without any external RESET circuitry.
2. Three different reference levels are selectable through the option byte according to the application requirement.

LVD application note

Application software can detect a reset caused by the LVD by reading the LVDRF bit in the CRSR register.

This bit is set by hardware when a LVD reset is generated and cleared by software (writing zero).

Figure 12. Low Voltage Detector vs Reset

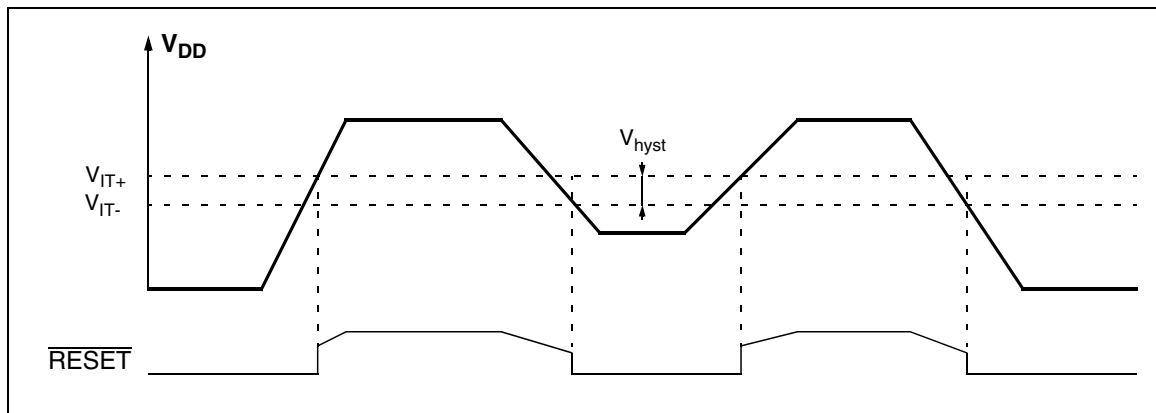

8.2 RESET SEQUENCE MANAGER (RSM)

8.2.1 Introduction

The reset sequence manager includes three RESET sources as shown in Figure 14:

- External $\overline{\text{RESET}}$ source pulse
- Internal LVD RESET (Low Voltage Detection)
- Internal WATCHDOG RESET

These sources act on the $\overline{\text{RESET}}$ pin and it is always kept low during the delay phase.

The RESET service routine vector is fixed at addresses FFFEh-FFFFh in the ST7 memory map.

The basic RESET sequence consists of three phases as shown in Figure 13:

- Delay depending on the RESET source
- 4096 CPU clock cycle delay
- RESET vector fetch

The 4096 CPU clock cycle delay allows the oscillator to stabilise and ensures that recovery has taken place from the Reset state.

The RESET vector fetch phase duration is 2 clock cycles.

Figure 13. RESET Sequence Phases

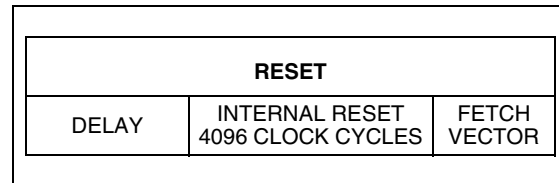
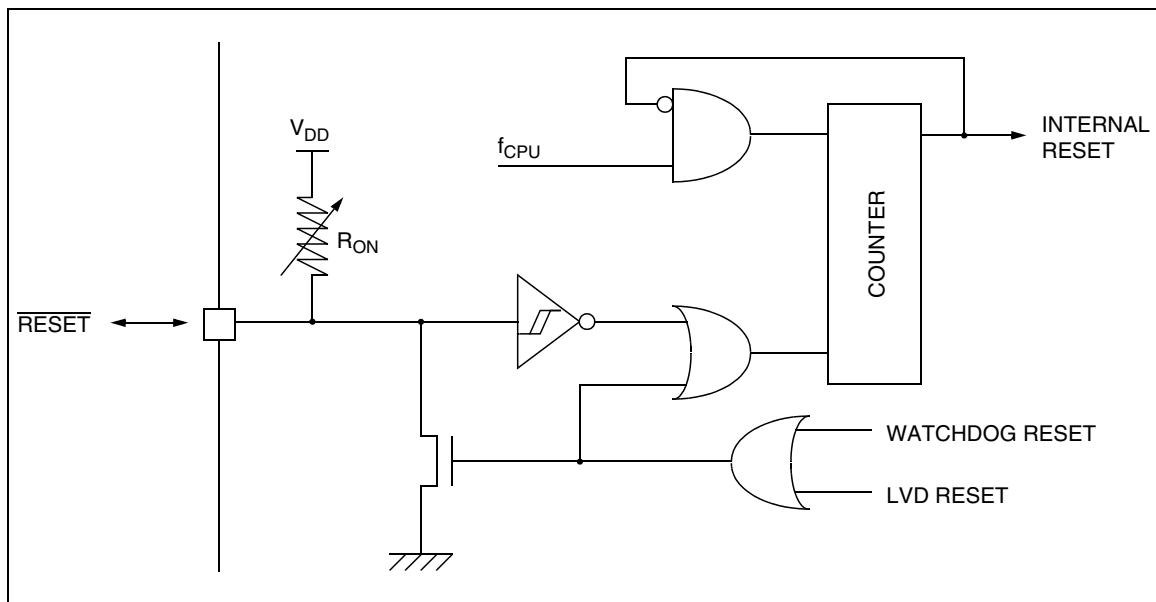

Figure 14. Reset Block Diagram



RESET SEQUENCE MANAGER (Cont'd)

8.2.2 Asynchronous External RESET Pin

The $\overline{\text{RESET}}$ pin is both an input and an open-drain output with integrated R_{ON} weak pull-up resistor. This pull-up has no fixed value but varies in accordance with the input voltage. It can be pulled low by external circuitry to reset the device. See [ELECTRICAL CHARACTERISTICS](#) section for more details.

A RESET signal originating from an external source must have a duration of at least $t_{\text{h(RSTL)in}}$ in order to be recognized. This detection is asynchronous and therefore the MCU can enter reset state even in Halt mode.

The $\overline{\text{RESET}}$ pin is an asynchronous signal which plays a major role in EMS performance. In a noisy environment, it is recommended to follow the guidelines mentioned in the [ELECTRICAL CHARACTERISTICS](#) section.

Two RESET sequences can be associated with this RESET source: short or long external reset pulse (see [Figure 15](#)).

Starting from the external RESET pulse recognition, the device RESET pin acts as an output that is pulled low during at least $t_{\text{w(RSTL)out}}$.

8.2.3 Internal Low Voltage Detection RESET

Two different RESET sequences caused by the internal LVD circuitry can be distinguished:

- Power-On RESET
- Voltage Drop RESET

The device $\overline{\text{RESET}}$ pin acts as an output that is pulled low when $V_{\text{DD}} < V_{\text{IT+}}$ (rising edge) or $V_{\text{DD}} < V_{\text{IT-}}$ (falling edge) as shown in [Figure 15](#).

The LVD filters spikes on V_{DD} larger than $t_{\text{g(VDD)}}$ to avoid parasitic resets.

8.2.4 Internal Watchdog RESET

The RESET sequence generated by an internal Watchdog counter overflow is shown in [Figure 15](#).

Starting from the Watchdog counter underflow, the device $\overline{\text{RESET}}$ pin acts as an output that is pulled low during at least $t_{\text{w(RSTL)out}}$.

Figure 15. RESET Sequences

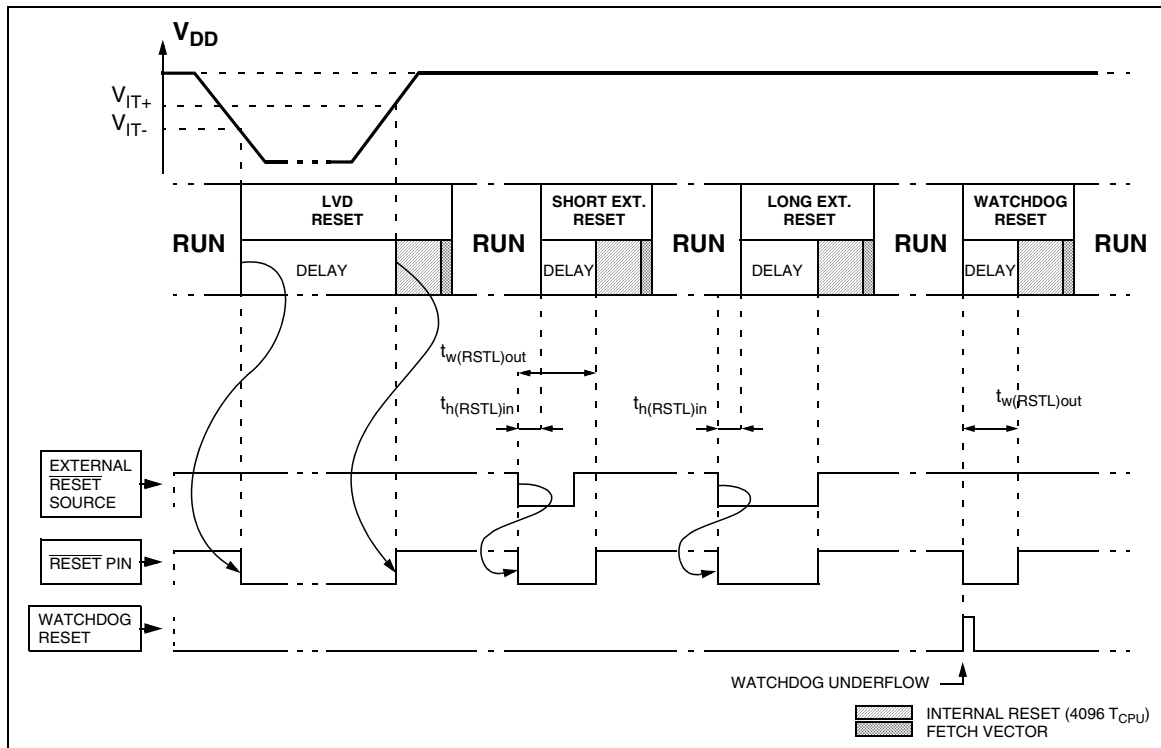

8.3 MULTI-OSCILLATOR (MO)

The main clock of the ST7 can be generated by four different source types coming from the multi-oscillator block:

- an external source
- 4 crystal or ceramic resonator oscillators
- an external RC oscillator
- an internal high frequency RC oscillator

Each oscillator is optimized for a given frequency range in terms of consumption and is selectable through the option byte. The associated hardware configuration are shown in Table 4. Refer to the [ELECTRICAL CHARACTERISTICS](#) section for more details.

External Clock Source

In this external clock mode, a clock signal (square, sinus or triangle) with ~50% duty cycle has to drive the OSC1 pin while the OSC2 pin is tied to ground.

Crystal/Ceramic Oscillators

This family of oscillators has the advantage of producing a very accurate rate on the main clock of the ST7. The selection within a list of four oscillators with different frequency ranges has to be done by option byte in order to reduce consumption. In this mode of the multi-oscillator, the resonator and the load capacitors have to be placed as close as possible to the oscillator pins in order to minimize output distortion and start-up stabilization time. The loading capacitance values must be adjusted according to the selected oscillator.

These oscillators are not stopped during the RESET phase to avoid losing time in the oscillator start-up phase.

External RC Oscillator

This oscillator allows a low cost solution for the main clock of the ST7 using only an external resistor and an external capacitor. The frequency of the external RC oscillator (in the range of some MHz) is fixed by the resistor and the capacitor values. Consequently in this MO mode, the accuracy of the clock is dependent on V_{DD} , T_A , process variations and the accuracy of the discrete components used. This option should not be used in applications that require accurate timing.

Internal RC Oscillator

The internal RC oscillator mode is based on the same principle as the external RC oscillator including the resistance and the capacitance of the device. This mode is the most cost effective one with

the drawback of a lower frequency accuracy. Its frequency is in the range of several MHz. This option should not be used in applications that require accurate timing.

In this mode, the two oscillator pins have to be tied to ground.

Table 4. ST7 Clock Sources

	Hardware Configuration
External Clock	
Crystal/Ceramic Resonators	
External RC Oscillator	
Internal RC Oscillator	

8.4 CLOCK SECURITY SYSTEM (CSS)

The Clock Security System (CSS) protects the ST7 against main clock problems. To allow the integration of the security features in the applications, it is based on a clock filter control and an internal safe oscillator. The CSS can be enabled or disabled by option byte.

8.4.1 Clock Filter Control

The clock filter is based on a clock frequency limitation function.

This filter function is able to detect and filter high frequency spikes on the ST7 main clock.

If the oscillator is not working properly (e.g. working at a harmonic frequency of the resonator), the current active oscillator clock can be totally filtered, and then no clock signal is available for the ST7 from this oscillator anymore. If the original clock source recovers, the filtering is stopped automatically and the oscillator supplies the ST7 clock.

8.4.2 Safe Oscillator Control

The safe oscillator of the CSS block is a low frequency back-up clock source (see Figure 16).

If the clock signal disappears (due to a broken or disconnected resonator...) during a safe oscillator period, the safe oscillator delivers a low frequency clock signal which allows the ST7 to perform some rescue operations.

Automatically, the ST7 clock source switches back from the safe oscillator if the original clock source recovers.

Limitation detection

The automatic safe oscillator selection is notified by hardware setting the CSSD bit of the CRSR register. An interrupt can be generated if the CSSIE bit has been previously set.

These 2 bits are described in the CRSR register description.

8.4.3 Low Power Modes

Mode	Description
WAIT	No effect on CSS. CSS interrupt cause the device to exit from Wait mode.
HALT	The CRSR register is frozen. The CSS (including the safe oscillator) is disabled until Halt mode is exited. The previous CSS configuration resumes when the MCU is woken up by an interrupt with "exit from Halt mode" capability or from the counter reset value when the MCU is woken up by a RESET.

8.4.4 Interrupts

The CSS interrupt event generates an interrupt if the corresponding Enable Control Bit (CSSIE) is set and the interrupt mask in the CC register is reset (RIM instruction).

Interrupt Event	Event Flag	Enable Control Bit	Exit from Wait	Exit from Halt ¹⁾
CSS event detection (safe oscillator activated as main clock)	CSSD	CSSIE	Yes	No

Notes:

1. This interrupt allows to exit from Active Halt mode if this mode is available in the MCU.

Figure 16. Clock Filter Function and Safe Oscillator Function

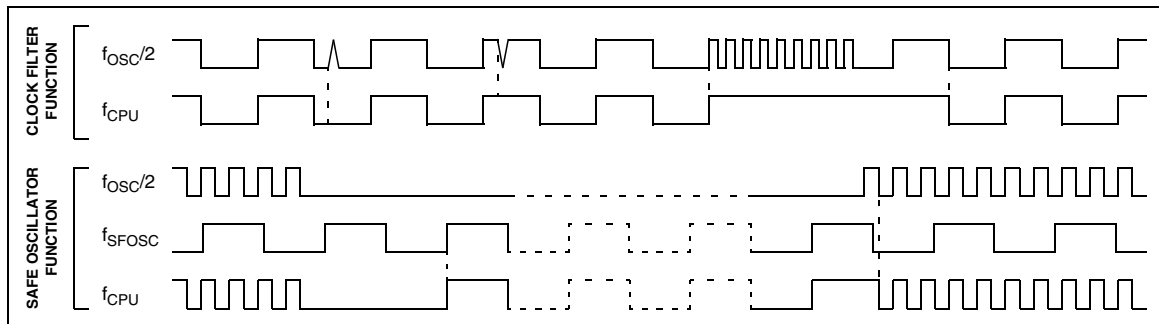

8.5 SUPPLY, RESET AND CLOCK REGISTER DESCRIPTION

Read/Write

Reset Value: 000x 000x (xxh)

7								0
0	0	0	LVD RF	0	CSS IE	CSS D	WDG RF	

Bit 7:5 = **Reserved**, always read as 0.

Bit 4 = **LVDRF** *LVD reset flag*

This bit indicates that the last RESET was generated by the LVD block. It is set by hardware (LVD reset) and cleared by software (writing zero). See WDGRF flag description for more details. When the LVD is disabled by option byte, the LVDRF bit value is undefined.

Bit 3 = **Reserved**, always read as 0.

Bit 2 = **CSSIE** *Clock security syst interrupt enable*

This bit enables the interrupt when a disturbance is detected by the clock security system (CSSD bit set). It is set and cleared by software.

0: Clock security system interrupt disabled

1: Clock security system interrupt enabled

Refer to [Table 6, "Interrupt Mapping," on page 35](#) for more details on the CSS interrupt vector. When the CSS is disabled by option byte, the CSSIE bit has no effect.

Bit 1 = **CSSD** *Clock security system detection*

This bit indicates that the safe oscillator of the clock security system block has been selected by hardware due to a disturbance on the main clock signal (f_{OSC}). It is set by hardware and cleared by reading the CRSR register when the original oscillator recovers.

0: Safe oscillator is not active

1: Safe oscillator has been activated

When the CSS is disabled by option byte, the CSSD bit value is forced to 0.

Bit 0 = **WDGRF** *Watchdog reset flag*

This bit indicates that the last RESET was generated by the watchdog peripheral. It is set by hardware (Watchdog RESET) and cleared by software (writing zero) or an LVD RESET (to ensure a stable cleared state of the WDGRF flag when the CPU starts).

Combined with the LVDRF flag information, the flag description is given by the following table.

RESET Sources	LVDRF	WDGRF
External RESET pin	0	0
Watchdog	0	1
LVD	1	X

Application notes

The LVDRF flag is not cleared when another RESET type occurs (external or watchdog), the LVDRF flag remains set to keep trace of the original failure.

In this case, a watchdog reset can be detected by software while an external reset can not.

Table 5. Clock, Reset and Supply Register Map and Reset Values

Address (Hex.)	Register Label	7	6	5	4	3	2	1	0
002Bh	CRSR Reset Value	0	0	0	LVDRF x	0	CFIE 0	CSSD 0	WDGRF x

9 INTERRUPTS

The ST7 core may be interrupted by one of two different methods: maskable hardware interrupts as listed in the [Interrupt Mapping](#) table and a non-maskable software interrupt (TRAP). The Interrupt processing flowchart is shown in [Figure 17](#).

The maskable interrupts must be enabled by clearing the I bit in order to be serviced. However, disabled interrupts may be latched and processed when they are enabled (see [EXTERNAL INTERRUPTS](#) subsection).

Note: After reset, all interrupts are disabled.

When an interrupt has to be serviced:

- Normal processing is suspended at the end of the current instruction execution.
- The PC, X, A and CC registers are saved onto the stack.
- The I bit of the CC register is set to prevent additional interrupts.
- The PC is then loaded with the interrupt vector of the interrupt to service and the first instruction of the interrupt service routine is fetched (refer to the [Interrupt Mapping](#) table for vector addresses).

The interrupt service routine should finish with the IRET instruction which causes the contents of the saved registers to be recovered from the stack.

Note: As a consequence of the IRET instruction, the I bit will be cleared and the main program will resume.

Priority Management

By default, a servicing interrupt cannot be interrupted because the I bit is set by hardware entering in interrupt routine.

In the case when several interrupts are simultaneously pending, a hardware priority defines which one will be serviced first (see the [Interrupt Mapping](#) table).

Interrupts and Low Power Mode

All interrupts allow the processor to leave the Wait low power mode. Only external and specifically mentioned interrupts allow the processor to leave the Halt low power mode (refer to the “Exit from Halt” column in the [Interrupt Mapping](#) table).

9.1 NON-MASKABLE SOFTWARE INTERRUPT

This interrupt is entered when the TRAP instruction is executed regardless of the state of the I bit.

It will be serviced according to the flowchart on [Figure 17](#).

9.2 EXTERNAL INTERRUPTS

External interrupt vectors can be loaded into the PC register if the corresponding external interrupt occurred and if the I bit is cleared. These interrupts allow the processor to leave the Halt low power mode.

The external interrupt polarity is selected through the miscellaneous register or interrupt register (if available).

An external interrupt triggered on edge will be latched and the interrupt request automatically cleared upon entering the interrupt service routine.

If several input pins, connected to the same interrupt vector, are configured as interrupts, their signals are logically NANDed before entering the edge/level detection block.

Caution: The type of sensitivity defined in the Miscellaneous or Interrupt register (if available) applies to the ei source. In case of a NANDed source (as described in the [I/O PORTS](#) section), a low level on an I/O pin configured as input with interrupt, masks the interrupt request even in case of rising-edge sensitivity.

9.3 PERIPHERAL INTERRUPTS

Different peripheral interrupt flags in the status register are able to cause an interrupt when they are active if both:

- The I bit of the CC register is cleared.
- The corresponding enable bit is set in the control register.

If any of these two conditions is false, the interrupt is latched and thus remains pending.

Clearing an interrupt request is done by:

- Writing “0” to the corresponding bit in the status register or
- Access to the status register while the flag is set followed by a read or write of an associated register.

Note: The clearing sequence resets the internal latch. A pending interrupt (that is, waiting to be enabled) will therefore be lost if the clear sequence is executed.

10 POWER SAVING MODES

10.1 INTRODUCTION

To give a large measure of flexibility to the application in terms of power consumption, four main power saving modes are implemented in the ST7 (see Figure 18): Slow, Wait (Slow Wait), Active Halt and Halt.

After a RESET the normal operating mode is selected by default (RUN mode). This mode drives the device (CPU and embedded peripherals) by means of a master clock which is based on the main oscillator frequency divided by 2 (f_{CPU}).

From RUN mode, the different power saving modes may be selected by setting the relevant register bits or by calling the specific ST7 software instruction whose action depends on the oscillator status.

Figure 18. Power Saving Mode Transitions

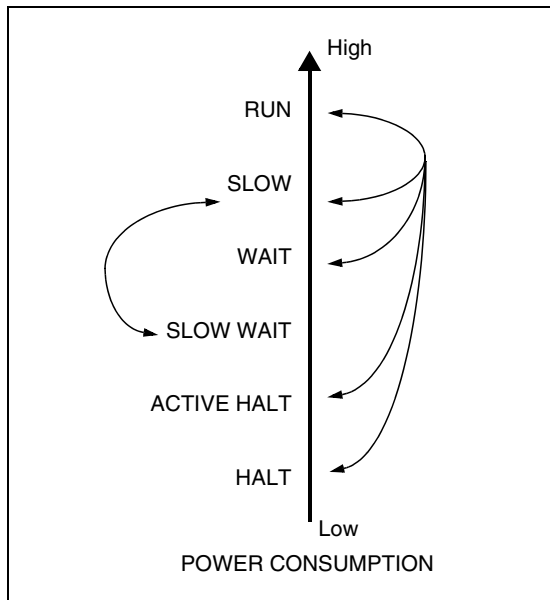

10.2 SLOW MODE

This mode has two targets:

- To reduce power consumption by decreasing the internal clock in the device,
- To adapt the internal clock frequency (f_{CPU}) to the available supply voltage.

Slow mode is controlled by three bits in the MISCR1 register: the SMS bit which enables or disables Slow mode and two CPx bits which select the internal slow frequency (f_{CPU}).

In this mode, the oscillator frequency can be divided by 4, 8, 16 or 32 instead of 2 in normal operating mode. The CPU and peripherals are clocked at this lower frequency.

Note: Slow Wait mode is activated when entering the Wait mode while the device is already in Slow mode.

Figure 19. Slow Mode Clock Transitions

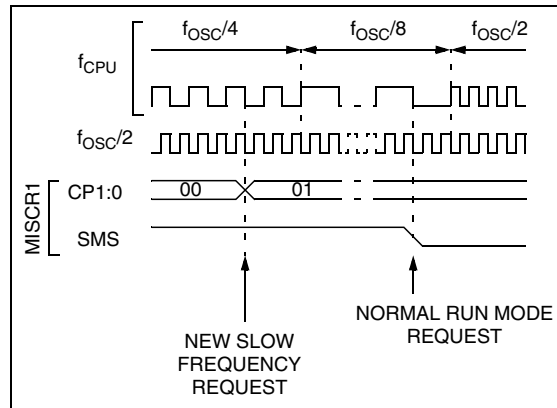

POWER SAVING MODES (Cont'd)

10.3 WAIT MODE

Wait mode places the MCU in a low power consumption mode by stopping the CPU. This power saving mode is selected by calling the WFI instruction.

All peripherals remain active. During Wait mode, the I bit of the CC register is cleared, to enable all interrupts. All other registers and memory remain unchanged. The MCU remains in Wait mode until an interrupt or RESET occurs, whereupon the Program Counter branches to the starting address of the interrupt or Reset service routine.

The MCU will remain in Wait mode until a Reset or an Interrupt occurs, causing it to wake up.

Refer to [Figure 20](#).

Figure 20. Wait Mode Flowchart

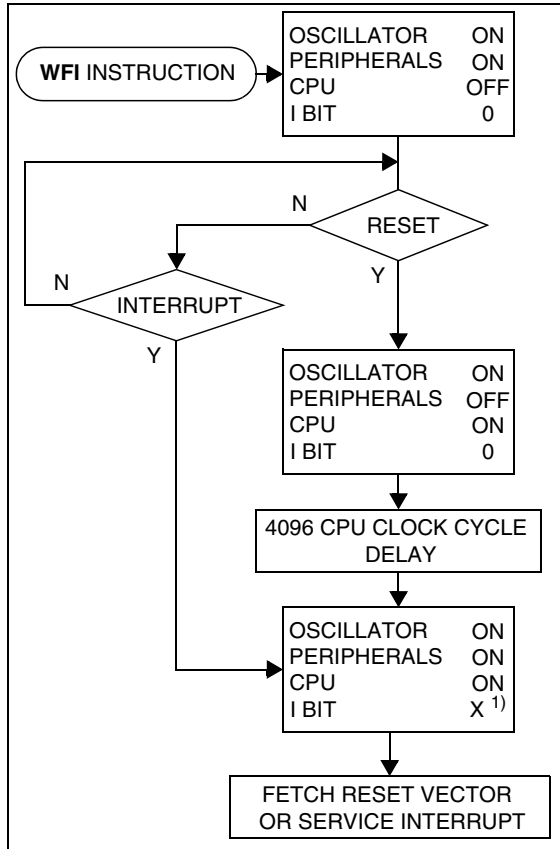

Note:

1. Before servicing an interrupt, the CC register is pushed on the stack. The I bit of the CC register is set during the interrupt routine and cleared when the CC register is popped.

POWER SAVING MODES (Cont'd)

10.4 ACTIVE HALT AND HALT MODES

Active Halt and Halt modes are the two lowest power consumption modes of the MCU. They are both entered by executing the HALT instruction. The decision to enter either in Active Halt or Halt mode is given by the MCC/RTC interrupt enable flag (OIE bit in MCCSR register).

MCCSR OIE bit	Power Saving Mode entered when HALT instruction is executed
0	Halt mode
1	Active Halt mode

10.4.1 Active Halt Mode

Active Halt mode is the lowest power consumption mode of the MCU with a real-time clock available. It is entered by executing the HALT instruction when the OIE bit of the Main Clock Controller Status register (MCCSR) is set (see Section 13.2 "MAIN CLOCK CONTROLLER WITH REAL-TIME CLOCK TIMER (MCC/RTC)" on page 53 for more details on the MCCSR register).

The MCU can exit Active Halt mode on reception of either an MCC/RTC interrupt, a specific interrupt (see Table 6, "Interrupt Mapping," on page 35) or a RESET. When exiting Active Halt mode by means of a RESET or an interrupt, a 4096 CPU cycle delay occurs. After the start up delay, the CPU resumes operation by servicing the interrupt or by fetching the reset vector which woke it up (see Figure 22).

When entering Active Halt mode, the I bit in the CC register is cleared to enable interrupts. Therefore, if an interrupt is pending, the MCU wakes up immediately.

In Active Halt mode, only the main oscillator and its associated counter (MCC/RTC) are running to keep a wake-up time base. All other peripherals are not clocked except those which get their clock supply from another clock generator (such as external or auxiliary oscillator).

The safeguard against staying locked in Active Halt mode is provided by the oscillator interrupt.

Note: As soon as the interrupt capability of one of the oscillators is selected (MCCSR.OIE bit set), entering Active Halt mode while the Watchdog is active does not generate a RESET.

This means that the device cannot spend more than a defined delay in this power saving mode.

Figure 21. Active Halt Timing Overview

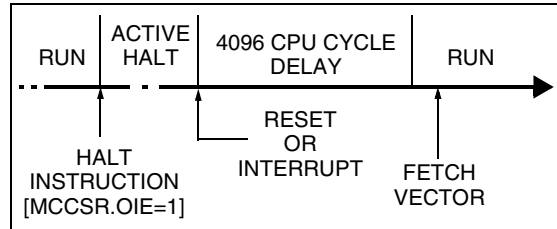
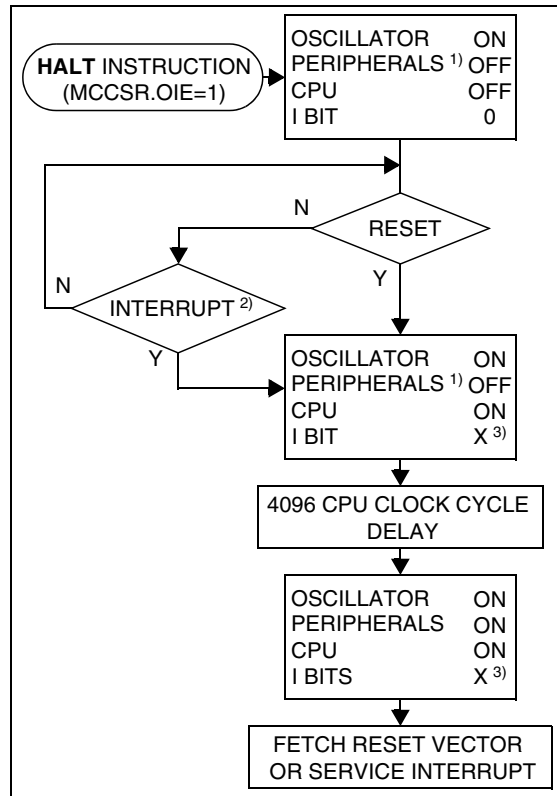

Figure 22. Active Halt Mode Flowchart



Notes:

1. Peripheral clocked with an external clock source can still be active.
2. Only the MCC/RTC interrupt and some specific interrupts can exit the MCU from Active Halt mode (such as external interrupt). Refer to Table 6, "Interrupt Mapping," on page 35 for more details.
3. Before servicing an interrupt, the CC register is pushed on the stack. The I bit of the CC register is set during the interrupt routine and cleared when the CC register is popped.

POWER SAVING MODES (Cont'd)

10.4.2 Halt Mode

The Halt mode is the lowest power consumption mode of the MCU. It is entered by executing the HALT instruction when the OIE bit of the Main Clock Controller Status register (MCCSR) is cleared (see Section 13.2 "MAIN CLOCK CONTROLLER WITH REAL-TIME CLOCK TIMER (MCC/RTC)" on page 53 for more details on the MCCSR register).

The MCU can exit Halt mode on reception of either a specific interrupt (see Table 6, "Interrupt Mapping," on page 35) or a RESET. When exiting Halt mode by means of a RESET or an interrupt, the oscillator is immediately turned on and the 4096 CPU cycle delay is used to stabilize the oscillator. After the start up delay, the CPU resumes operation by servicing the interrupt or by fetching the reset vector which woke it up (see Figure 24).

When entering Halt mode, the I bit in the CC register is forced to 0 to enable interrupts. Therefore, if an interrupt is pending, the MCU wakes immediately.

In Halt mode, the main oscillator is turned off causing all internal processing to be stopped, including the operation of the on-chip peripherals. All peripherals are not clocked except the ones which get their clock supply from another clock generator (such as an external or auxiliary oscillator).

The compatibility of Watchdog operation with Halt mode is configured by the "WDGHALT" option bit of the option byte. The HALT instruction when executed while the Watchdog system is enabled, can generate a Watchdog RESET (see Section 17.2 on page 143 for more details).

Figure 23. HALT Timing Overview

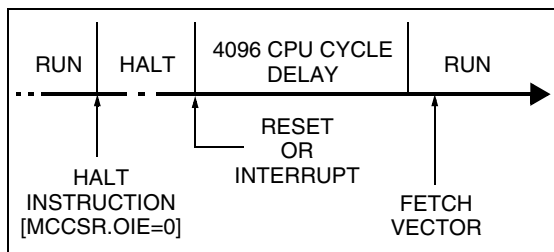
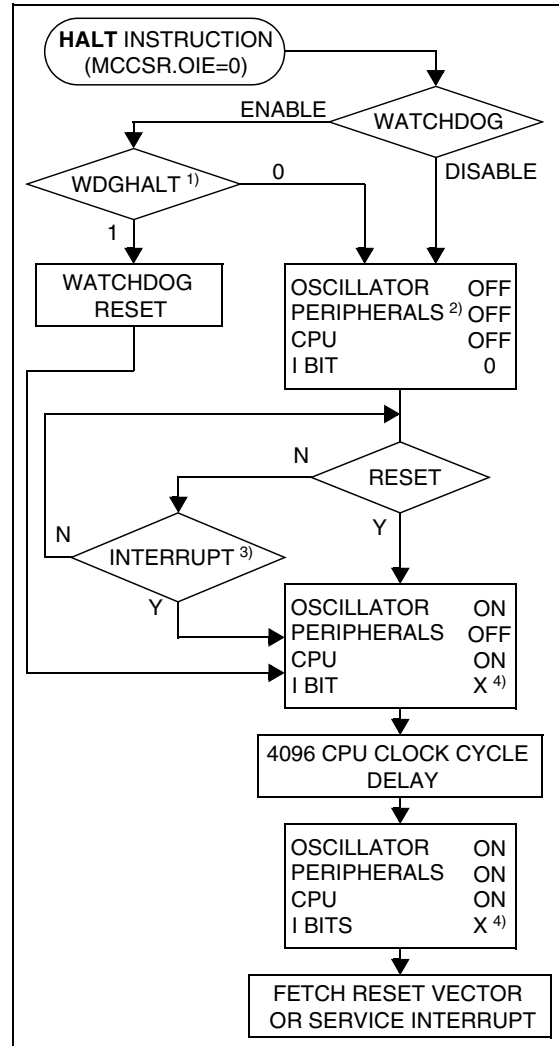

Figure 24. Halt Mode Flowchart



Notes:

1. WDGHALT is an option bit. See OPTION BYTES section for more details.
2. Peripheral clocked with an external clock source can still be active.
3. Only some specific interrupts can exit the MCU from Halt mode (such as external interrupt). Refer to Table 6, "Interrupt Mapping," on page 35 for more details.
4. Before servicing an interrupt, the CC register is pushed on the stack. The I bit of the CC register is set during the interrupt routine and cleared when the CC register is popped.

11 I/O PORTS

11.1 INTRODUCTION

The I/O ports offer different functional modes:

- transfer of data through digital inputs and outputs and for specific pins:
- external interrupt generation
- alternate signal input/output for the on-chip peripherals.

An I/O port contains up to eight pins. Each pin can be programmed independently as digital input (with or without interrupt generation) or digital output.

11.2 FUNCTIONAL DESCRIPTION

Each port has two main registers:

- Data Register (DR)
- Data Direction Register (DDR)

and one optional register:

- Option Register (OR)

Each I/O pin may be programmed using the corresponding register bits in the DDR and OR registers: bit X corresponding to pin X of the port. The same correspondence is used for the DR register.

The following description takes into account the OR register (for specific ports which do not provide this register refer to the [I/O PORT IMPLEMENTATION](#) section). The generic I/O block diagram is shown in [Figure 25](#).

11.2.1 Input Modes

The input configuration is selected by clearing the corresponding DDR register bit.

In this case, reading the DR register returns the digital value applied to the external I/O pin.

Different input modes can be selected by software through the OR register.

Notes:

1. Writing the DR register modifies the latch value but does not affect the pin status.
2. When switching from input to output mode, the DR register has to be written first to drive the correct level on the pin as soon as the port is configured as an output.
3. Do not use read/modify/write instructions (BSET or BRES) to modify the DR register.

External interrupt function

When an I/O is configured as Input with Interrupt, an event on this I/O can generate an external interrupt request to the CPU.

Each pin can independently generate an interrupt request. The interrupt sensitivity is independently

programmable using the sensitivity bits in the Miscellaneous register.

Each external interrupt vector is linked to a dedicated group of I/O port pins (see pinout description and interrupt section). If several input pins are selected simultaneously as interrupt source, these are logically NANDed. For this reason if one of the interrupt pins is tied low, it masks the other ones.

In case of a floating input with interrupt configuration, special care must be taken when changing the configuration (see [Figure 26](#)).

The external interrupts are hardware interrupts, which means that the request latch (not accessible directly by the application) is automatically cleared when the corresponding interrupt vector is fetched. To clear an unwanted pending interrupt by software, the sensitivity bits in the Miscellaneous register must be modified.

11.2.2 Output Modes

The output configuration is selected by setting the corresponding DDR register bit. In this case, writing the DR register applies this digital value to the I/O pin through the latch. Then reading the DR register returns the previously stored value.

Two different output modes can be selected by software through the OR register: Output push-pull and open-drain.

DR register value and output pin status:

DR	Push-pull	Open-drain
0	V _{SS}	V _{SS}
1	V _{DD}	Floating

11.2.3 Alternate Functions

When an on-chip peripheral is configured to use a pin, the alternate function is automatically selected. This alternate function takes priority over the standard I/O programming.

When the signal is coming from an on-chip peripheral, the I/O pin is automatically configured in output mode (push-pull or open drain according to the peripheral).

When the signal is going to an on-chip peripheral, the I/O pin must be configured in input mode. In this case, the pin state is also digitally readable by addressing the DR register.

Note: Input pull-up configuration can cause unexpected value at the input of the alternate peripheral input. When an on-chip peripheral use a pin as input and output, this pin has to be configured in input floating mode.

I/O PORTS (Cont'd)

Figure 25. I/O Port General Block Diagram

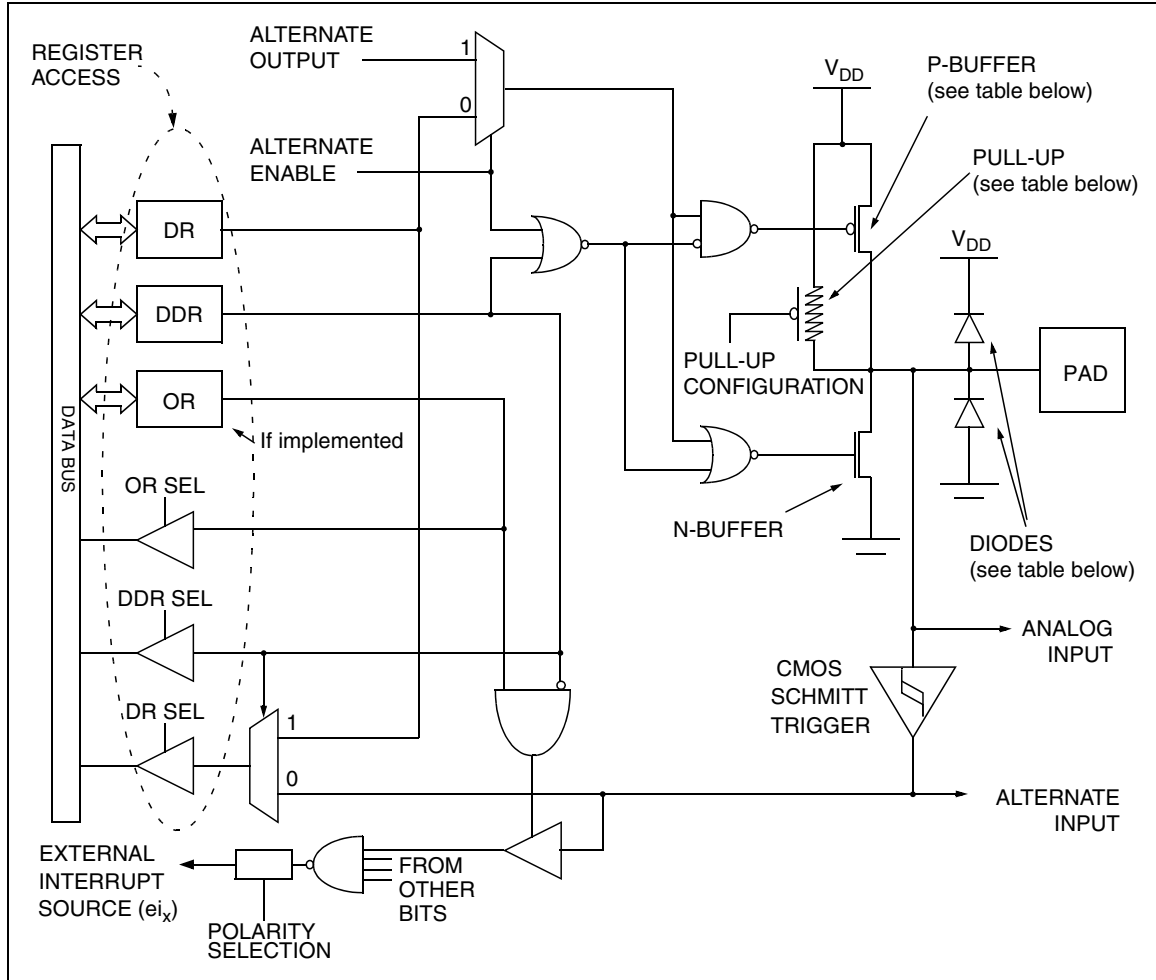

Table 7. I/O Port Mode Options

Configuration Mode		Pull-Up	P-Buffer	Diodes	
				to V _{DD}	to V _{SS}
Input	Floating with/without Interrupt	Off	Off	On	On
	Pull-up with/without Interrupt	On			
Output	Push-pull	Off	On	On	On
	Open Drain (logic level)		Off		
	True Open Drain	NI	NI	NI (see note)	

Legend: NI - not implemented
 Off - implemented not activated
 On - implemented and activated

Note: The diode to V_{DD} is not implemented in the true open drain pads. A local protection between the pad and V_{SS} is implemented to protect the device against positive stress.

I/O PORTS (Cont'd)

Table 8. I/O Port Configurations

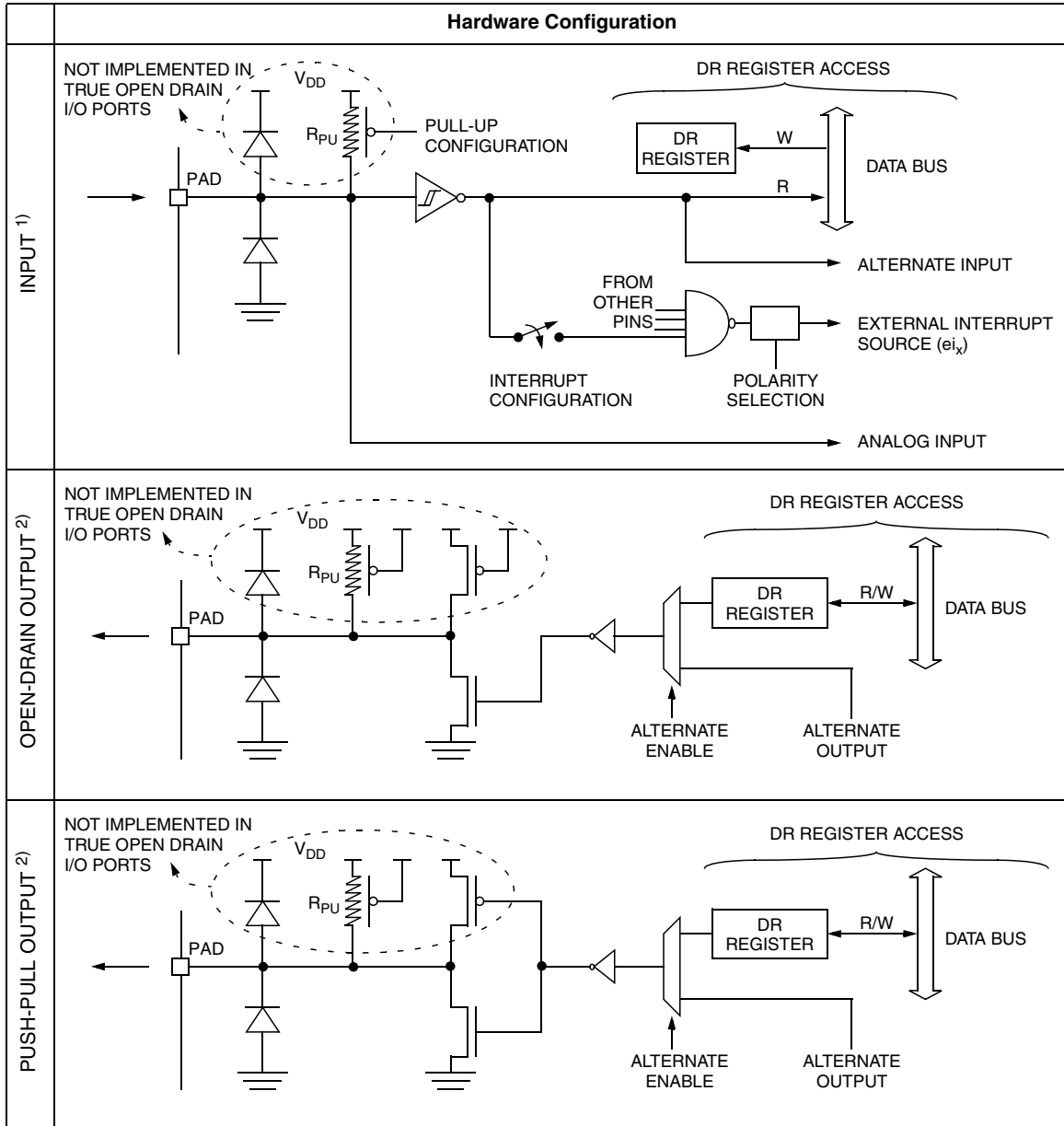

Notes:

1. When the I/O port is in input configuration and the associated alternate function is enabled as an output, reading the DR register will read the alternate function output status.
2. When the I/O port is in output configuration and the associated alternate function is enabled as an input, the alternate function reads the pin status given by the DR register content.

I/O PORTS (Cont'd)

CAUTION: The alternate function must not be activated as long as the pin is configured as input with interrupt, in order to avoid generating spurious interrupts.

Analog alternate function

When the pin is used as an ADC input, the I/O must be configured as floating input. The analog multiplexer (controlled by the ADC registers) switches the analog voltage present on the selected pin to the common analog rail which is connected to the ADC input.

It is recommended not to change the voltage level or loading on any port pin while conversion is in progress. Furthermore it is recommended not to have clocking pins located close to a selected analog pin.

WARNING: The analog input voltage level must be within the limits stated in the absolute maximum ratings.

11.3 I/O PORT IMPLEMENTATION

The hardware implementation on each I/O port depends on the settings in the DDR and OR registers and specific feature of the I/O port such as ADC input or true open drain.

Switching these I/O ports from one state to another should be done in a sequence that prevents unwanted side effects. Recommended safe transitions are illustrated in [Figure 26](#). Other transitions are potentially risky and should be avoided, since they are likely to present unwanted side-effects such as spurious interrupt generation.

Figure 26. Interrupt I/O Port State Transitions

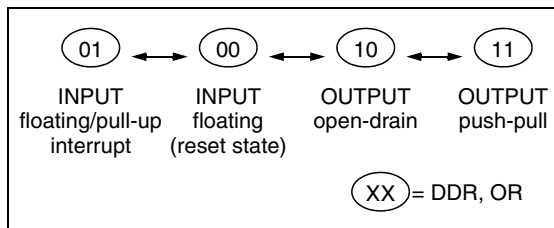

The I/O port register configurations are summarized as follows.

Standard Ports

PA5:4, PC7:0, PD7:0, PE7:4, PE1:0, PF7:6, PF4

MODE	DDR	OR
floating input	0	0
pull-up input	0	1
open drain output	1	0
push-pull output	1	1

Interrupt Ports

PA2:0, PB7:5, PB2:0, PF1:0 (with pull-up)

MODE	DDR	OR
floating input	0	0
pull-up interrupt input	0	1
open drain output	1	0
push-pull output	1	1

PA3, PB4, PB3, PF2 (without pull-up)

MODE	DDR	OR
floating input	0	0
floating interrupt input	0	1
open drain output	1	0
push-pull output	1	1

True Open Drain Ports

PA7:6

MODE	DDR
floating input	0
open drain (high sink ports)	1

I/O PORTS (Cont'd)

11.4 LOW POWER MODES

Mode	Description
WAIT	No effect on I/O ports. External interrupts cause the device to exit from Wait mode.
HALT	No effect on I/O ports. External interrupts cause the device to exit from Halt mode.

11.5 INTERRUPTS

The external interrupt event generates an interrupt if the corresponding configuration is selected with DDR and OR registers and the I-bit in the CC register is reset (RIM instruction).

Interrupt Event	Event Flag	Enable Control Bit	Exit from Wait	Exit from Halt
External interrupt on selected external event	-	DDRx ORx	Yes	Yes

Table 9. Port Configuration

Port	Pin name	Input		Output		High-Sink
		OR = 0	OR = 1	OR = 0	OR = 1	
Port A	PA7:6	floating		true open-drain		Yes
	PA5:4	floating	pull-up	open drain	push-pull	
	PA3	floating	floating interrupt	open drain	push-pull	No
	PA2:0	floating	pull-up interrupt	open drain	push-pull	
Port B	PB4:3	floating	floating interrupt	open drain	push-pull	
	PB7:5, PB2:0	floating	pull-up interrupt	open drain	push-pull	
Port C	PC7:4, PC1:0	floating	pull-up	open drain	push-pull	Yes
	PC3:2	floating	pull-up	open drain	push-pull	
Port D	PD7:0	floating	pull-up	open drain	push-pull	No
Port E	PE7:4	floating	pull-up	open drain	push-pull	Yes
	PE1:0	floating	pull-up	open drain	push-pull	No
Port F	PF7:6	floating	pull-up	open drain	push-pull	Yes
	PF4	floating	pull-up	open drain	push-pull	No
	PF2	floating	floating interrupt	open drain	push-pull	
	PF1:0	floating	pull-up interrupt	open drain	push-pull	

I/O PORTS (Cont'd)

11.5.1 Register Description

DATA REGISTER (DR)

Port x Data Register
PxDR with x = A, B, C, D, E or F.

Read/Write

Reset Value: 0000 0000 (00h)

7							0
D7	D6	D5	D4	D3	D2	D1	D0

Bit 7:0 = **D[7:0]** *Data register 8 bits.*

The DR register has a specific behavior according to the selected input/output configuration. Writing the DR register is always taken into account even if the pin is configured as an input; this allows to always have the expected level on the pin when toggling to output mode. Reading the DR register returns either the DR register latch content (pin configured as output) or the digital value applied to the I/O pin (pin configured as input).

DATA DIRECTION REGISTER (DDR)

Port x Data Direction Register
PxDDR with x = A, B, C, D, E or F.

Read/Write

Reset Value: 0000 0000 (00h)

7							0
DD7	DD6	DD5	DD4	DD3	DD2	DD1	DD0

Bit 7:0 = **DD[7:0]** *Data direction register 8 bits.*

The DDR register gives the input/output direction configuration of the pins. Each bits is set and cleared by software.

0: Input mode
1: Output mode

OPTION REGISTER (OR)

Port x Option Register
PxOR with x = A, B, C, D, E or F.

Read/Write

Reset Value: 0000 0000 (00h)

7							0
O7	O6	O5	O4	O3	O2	O1	O0

Bit 7:0 = **O[7:0]** *Option register 8 bits.*

For specific I/O pins, this register is not implemented. In this case the DDR register is enough to select the I/O pin configuration.

The OR register allows to distinguish: in input mode if the pull-up with interrupt capability or the basic pull-up configuration is selected, in output mode if the push-pull or open drain configuration is selected.

Each bit is set and cleared by software.

Input mode:

0: floating input
1: pull-up input with or without interrupt

Output mode:

0: output open drain (with P-Buffer deactivated)
1: output push-pull

I/O PORTS (Cont'd)

Table 10. I/O Port Register Map and Reset Values

Address (Hex.)	Register Label	7	6	5	4	3	2	1	0
Reset Value of all IO port registers		0	0	0	0	0	0	0	0
0000h	PADR	MSB							LSB
0001h	PADDR								
0002h	PAOR 1)								
0004h	PCDR	MSB							LSB
0005h	PCDDR								
0006h	PCOR								
0008h	PBDR	MSB							LSB
0009h	PBDDR								
000Ah	PBOR 1)								
000Ch	PEDR	MSB							LSB
000Dh	PEDDR								
000Eh	PEOR 1)								
0010h	PDDR	MSB							LSB
0011h	PDDDR								
0012h	PDOR 1)								
0014h	PFDR	MSB							LSB
0015h	PFDDR								
0016h	PFOR								

Notes:

1) The bits corresponding to unavailable pins are forced to 1 by hardware, this affects the reset status value.

12 MISCELLANEOUS REGISTERS

The miscellaneous registers allow control over several different features such as the external interrupts or the I/O alternate functions.

12.1 I/O PORT INTERRUPT SENSITIVITY

The external interrupt sensitivity is controlled by the ISxx bits of the MISCR1 miscellaneous register. This control allows to have two fully independent external interrupt source sensitivities.

Each external interrupt source can be generated on four different events on the pin:

- Falling edge
- Rising edge
- Falling and rising edge
- Falling edge and low level

To guarantee correct functionality, the sensitivity bits in the MISCR1 register must be modified only when the I bit of the CC register is set to 1 (interrupt masked). See I/O port register and Miscellaneous register descriptions for more details on the programming.

12.2 I/O PORT ALTERNATE FUNCTIONS

The MISCR registers manage four I/O port miscellaneous alternate functions:

- Main clock signal (f_{CPU}) output on PF0
- A beep signal output on PF1 (with 3 selectable audio frequencies)
- SPI pin configuration:
 - \overline{SS} pin internal control to use the PC7 I/O port function while the SPI is active.

These functions are described in detail in the [Section 12 "MISCELLANEOUS REGISTERS" on page 47](#).

Figure 27. Ext. Interrupt Sensitivity

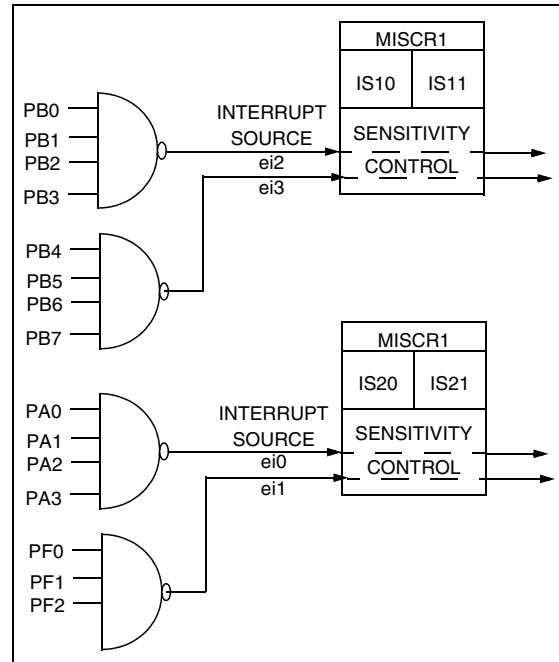

MISCELLANEOUS REGISTERS (Cont'd)

12.3 REGISTERS DESCRIPTION

MISCELLANEOUS REGISTER 1 (MISCR1)

Read/Write

Reset Value: 0000 0000 (00h)

7							0
IS11	IS10	MCO	IS21	IS20	CP1	CP0	SMS

Bit 7:6 = **IS1[1:0]** *ei2 and ei3 sensitivity*
 The interrupt sensitivity, defined using the IS1[1:0] bits, is applied to the following external interrupts: ei2 (port B3..0) and ei3 (port B7..4). These 2 bits can be written only when the I bit of the CC register is set to 1 (interrupt disabled).

External Interrupt Sensitivity	IS11	IS10
Falling edge and low level	0	0
Rising edge only	0	1
Falling edge only	1	0
Rising and falling edge	1	1

Bit 5 = **MCO** *Main clock out selection*
 This bit enables the MCO alternate function on the I/O port. It is set and cleared by software.
 0: MCO alternate function disabled (I/O pin free for general-purpose I/O)
 1: MCO alternate function enabled ($f_{OSC}/2$ on I/O port)

Note: To reduce power consumption, the MCO function is not active in Active Halt mode.

Bit 4:3 = **IS2[1:0]** *ei0 and ei1 sensitivity*
 The interrupt sensitivity, defined using the IS2[1:0] bits, is applied to the following external interrupts: ei0 (port A3..0) and ei1 (port F2..0). These 2 bits can be written only when the I bit of the CC register is set to 1 (interrupt disabled).

Bit 2:1 = **CP[1:0]** *CPU clock prescaler*
 These bits select the CPU clock prescaler which is applied in the different slow modes. Their action is conditioned by the setting of the SMS bit. These 2 bits are set and cleared by software.

f_{CPU} in Slow mode	CP1	CP0
$f_{OSC} / 4$	0	0
$f_{OSC} / 8$	1	0
$f_{OSC} / 16$	0	1
$f_{OSC} / 32$	1	1

Bit 0 = **SMS** *Slow mode select*
 This bit is set and cleared by software.
 0: Normal mode. $f_{CPU} = f_{OSC} / 2$
 1: Slow mode. f_{CPU} is given by CP1, CP0
 See low power consumption mode and MCC chapters for more details.

MISCELLANEOUS REGISTERS (Cont'd)

MISCELLANEOUS REGISTER 2 (MISCR2)

Read/Write

Reset Value: 0000 0000 (00h)

7							0
-	-	BC1	BC0	-	-	SSM	SSI

Bit 7:6 = **Reserved** *Must always be cleared*

Bit 5:4 = **BC[1:0]** *Beep control*

These 2 bits select the PF1 pin beep capability.

Beep mode with $f_{osc}=16MHz$		BC1	BC0
Off		0	0
~2 kHz	Output Beep signal ~50% duty cycle	0	1
~1 kHz		1	0
~500 Hz		1	1

The beep output signal is available in Active Halt mode but has to be disabled to reduce the consumption.

Bit 3:2 = **Reserved** *Must always be cleared*

Bit 1 = **SSM** \overline{SS} *mode selection*

It is set and cleared by software.

0: Normal mode - \overline{SS} uses information coming from the \overline{SS} pin of the SPI.

1: I/O mode, the SPI uses the information stored into bit SSI.

Bit 0 = **SSI** \overline{SS} *internal mode*

This bit replaces pin \overline{SS} of the SPI when bit SSM is set to 1. (see SPI description). It is set and cleared by software.

Table 11. Miscellaneous Register Map and Reset Values

Address (Hex.)	Register Label	7	6	5	4	3	2	1	0
0020h	MISCR1 Reset Value	IS11 0	IS10 0	MCO 0	IS21 0	IS20 0	CP1 0	CP0 0	SMS 0
0040h	MISCR2 Reset Value	0	0	BC1 0	BC0 0	0	0	SSM 0	SSI 0

13 ON-CHIP PERIPHERALS

13.1 WATCHDOG TIMER (WDG)

13.1.1 Introduction

The Watchdog timer is used to detect the occurrence of a software fault, usually generated by external interference or by unforeseen logical conditions, which causes the application program to abandon its normal sequence. The Watchdog circuit generates an MCU reset on expiry of a programmed time period, unless the program refreshes the counter's contents before the T6 bit becomes cleared.

13.1.2 Main Features

- Programmable timer (64 increments of 12288 CPU cycles)
- Programmable reset
- Reset (if watchdog activated) after a HALT instruction or when the T6 bit reaches zero

- Hardware Watchdog selectable by option byte
- Watchdog Reset indicated by status flag (in versions with Safe Reset option only)

13.1.3 Functional Description

The counter value stored in the CR register (bits T[6:0]), is decremented every 12288 machine cycles, and the length of the timeout period can be programmed by the user in 64 increments.

If the watchdog is activated (the WDGA bit is set) and when the 7-bit timer (bits T[6:0]) rolls over from 40h to 3Fh (T6 becomes cleared), it initiates a reset cycle pulling low the RESET pin for typically 30µs.

Figure 28. Watchdog Block Diagram

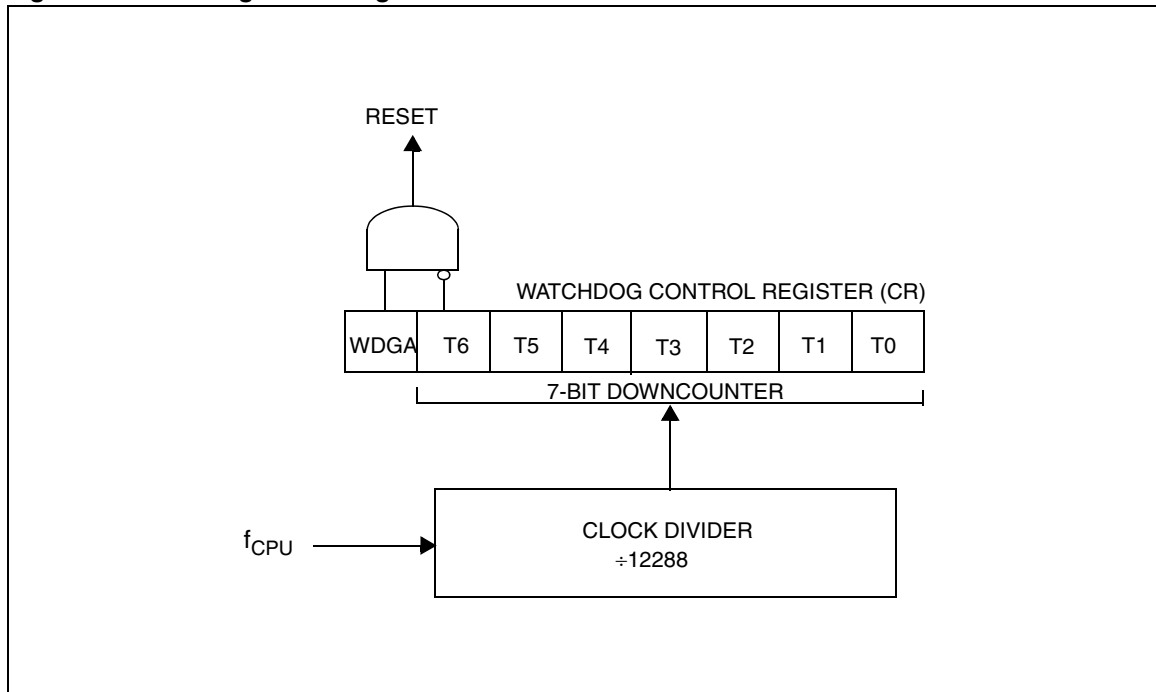

WATCHDOG TIMER (Cont'd)

The application program must write in the CR register at regular intervals during normal operation to prevent an MCU reset. The value to be stored in the CR register must be between FFh and C0h (see Table 12 .Watchdog Timing (f_{CPU} = 8 MHz)):

- The WDGA bit is set (watchdog enabled)
- The T6 bit is set to prevent generating an immediate reset
- The T[5:0] bits contain the number of increments which represents the time delay before the watchdog produces a reset.

Table 12. Watchdog Timing (f_{CPU} = 8 MHz)

	CR Register initial value	WDG timeout period (ms)
Max	FFh	98.304
Min	C0h	1.536

Notes: Following a reset, the watchdog is disabled. Once activated it cannot be disabled, except by a reset.

The T6 bit can be used to generate a software reset (the WDGA bit is set and the T6 bit is cleared).

If the watchdog is activated, the HALT instruction will generate a Reset.

13.1.4 Hardware Watchdog Option

If Hardware Watchdog is selected by option byte, the watchdog is always active and the WDGA bit in the CR is not used.

Refer to the device-specific Option Byte description.

13.1.5 Low Power Modes

Mode	Description
WAIT	No effect on Watchdog.
HALT	Immediate reset generation as soon as the HALT instruction is executed if the Watchdog is activated (WDGA bit is set).

13.1.6 Interrupts

None.

13.1.7 Register Description

CONTROL REGISTER (CR)

Read/Write

Reset Value: 0111 1111 (7Fh)

7							0
WDGA	T6	T5	T4	T3	T2	T1	T0

Bit 7 = **WDGA** Activation bit.

This bit is set by software and only cleared by hardware after a reset. When WDGA = 1, the watchdog can generate a reset.

0: Watchdog disabled

1: Watchdog enabled

Note: This bit is not used if the hardware watchdog option is enabled by option byte.

Bit 6:0 = **T[6:0]** 7-bit timer (MSB to LSB).

These bits contain the decremented value. A reset is produced when it rolls over from 40h to 3Fh (T6 becomes cleared).

STATUS REGISTER (SR)

Read/Write

Reset Value*: 0000 0000 (00h)

7							0
-	-	-	-	-	-	-	WDOGF

Bit 0 = **WDOGF** Watchdog flag.

This bit is set by a watchdog reset and cleared by software or a power on/off reset. This bit is useful for distinguishing power/on off or external reset and watchdog reset.

0: No Watchdog reset occurred

1: Watchdog reset occurred

* Only by software and power on/off reset

Note: This register is not used in versions without LVD Reset.

WATCHDOG TIMER (Cont'd)

Table 13. Watchdog Timer Register Map and Reset Values

Address (Hex.)	Register Label	7	6	5	4	3	2	1	0
002Ah	WDGCR Reset Value	WDGA 0	T6 1	T5 1	T4 1	T3 1	T2 1	T1 1	T0 1

13.2 MAIN CLOCK CONTROLLER WITH REAL-TIME CLOCK TIMER (MCC/RTC)

The Main Clock Controller consists of three different functions:

- a programmable CPU clock prescaler
- a clock-out signal to supply external devices
- a real-time clock timer with interrupt capability

Each function can be used independently and simultaneously.

13.2.1 Programmable CPU clock prescaler

The programmable CPU clock prescaler supplies the clock for the ST7 CPU and its internal peripherals. It manages Slow power saving mode (See Section 10.2 "SLOW MODE" on page 36 for more details).

The prescaler selects the f_{CPU} main clock frequency and is controlled by three bits in the MISCR1 register: CP[1:0] and SMS.

CAUTION: The prescaler does not act on the CAN peripheral clock source. This peripheral is always supplied by the $f_{OSC}/2$ clock source.

13.2.2 Clock-out capability

The clock-out capability is an alternate function of an I/O port pin that outputs a $f_{OSC}/2$ clock to drive external devices. It is controlled by the MCO bit in the MISCR1 register.

CAUTION: When selected, the clock out pin suspends the clock during Active Halt mode.

13.2.3 Real-time clock timer (RTC)

The counter of the real-time clock timer allows an interrupt to be generated based on an accurate real-time clock. Four different time bases depending directly on f_{OSC} are available. The whole functionality is controlled by four bits of the MCCR register: TB[1:0], OIE and OIF.

When the RTC interrupt is enabled (OIE bit set), the ST7 enters Active Halt mode when the HALT instruction is executed. See Section 10.4 "ACTIVE HALT AND HALT MODES" on page 38 for more details.

Figure 29. Main Clock Controller (MCC/RTC) Block Diagram

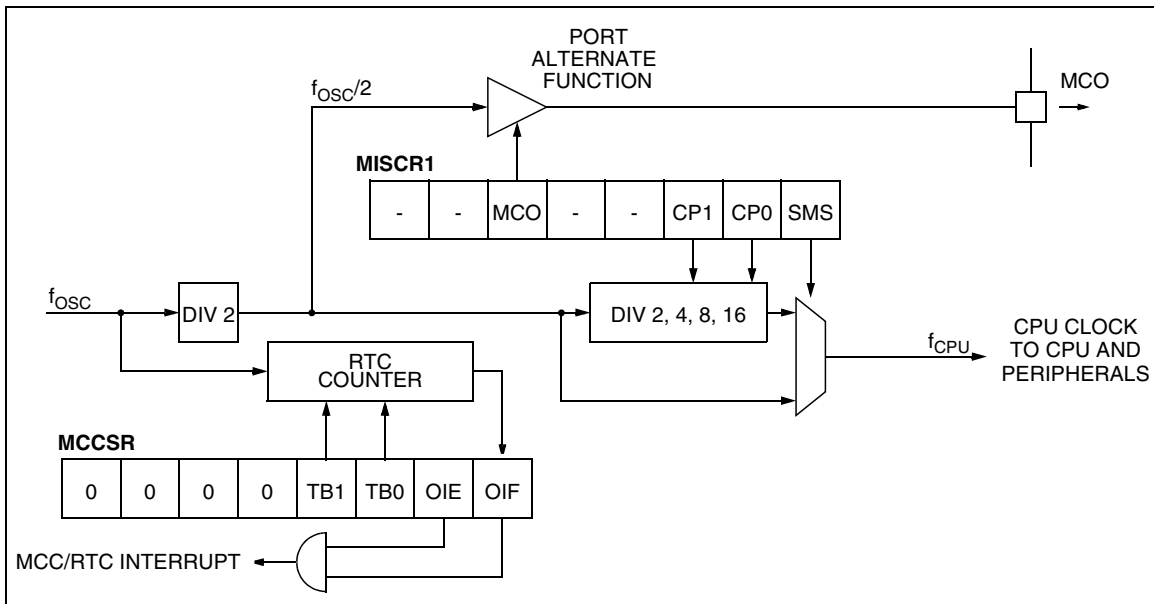

MAIN CLOCK CONTROLLER WITH REAL-TIME CLOCK TIMER (Cont'd)

MISCELLANEOUS REGISTER 1 (MISCR1)

See [Section 12 on page 47](#).

MAIN CLOCK CONTROL/STATUS REGISTER (MCCSR)

Read/Write

Reset Value: 0000 0001 (01h)

7							0
0	0	0	0	TB1	TB0	OIE	OIF

Bit 7:4 = Reserved, always read as 0.

Bit 3:2 = **TB[1:0]** *Time base control*

These bits select the programmable divider time base. They are set and cleared by software.

Counter Prescaler	Time Base		TB1	TB0
	f _{OSC} =8MHz	f _{OSC} =16MHz		
32000	4ms	2ms	0	0
64000	8ms	4ms	0	1
160000	20ms	10ms	1	0
400000	50ms	25ms	1	1

A modification of the time base is taken into account at the end of the current period (previously set) to avoid unwanted time shift. This allows to use this time base as a real-time clock.

Bit 1 = **OIE** *Oscillator interrupt enable*

This bit set and cleared by software.

0: Oscillator interrupt disabled

1: Oscillator interrupt enabled

This interrupt allows to exit from Active Halt mode. When this bit is set, calling the ST7 software HALT instruction enters the Active Halt power saving mode.

Bit 0 = **OIF** *Oscillator interrupt flag*

This bit is set by hardware and cleared by software reading the CSR register. It indicates when set that the main oscillator has measured the selected elapsed time (TB1:0).

0: Timeout not reached

1: Timeout reached

CAUTION: The BRES and BSET instructions must not be used on the MCCSR register to avoid unintentionally clearing the OIF bit.

13.2.4 Low Power Modes

Mod	Description
WAIT	No effect on MCC/RTC peripheral. MCC/RTC interrupt cause the device to exit from Wait mode.
ACTIVE HALT	No effect on MCC/RTC counter (OIE bit is set), the registers are frozen. MCC/RTC interrupt cause the device to exit from Active Halt mode.
HALT	MCC/RTC counter and registers are frozen. MCC/RTC operation resumes when the MCU is woken up by an interrupt with "exit from Halt" capability.

13.2.5 Interrupts

The MCC/RTC interrupt event generates an interrupt if the OIE bit of the MCCSR register is set and the interrupt mask in the CC register is not active (RIM instruction).

Interrupt Event	Event Flag	Enable Control Bit	Exit from Wait	Exit from Halt
Time base overflow event	OIF	OIE	Yes	No ¹⁾

Notes:

1. The MCC/RTC interrupt allows to exit from Active Halt mode, not from Halt mode.

Table 14. MCC Register Map and Reset Values

Address (Hex.)	Register Label	7	6	5	4	3	2	1	0
0029h	MCCSR Reset Value	0	0	0	0	TB1 0	TB0 0	OIE 0	OIF 1

13.3 16-BIT TIMER

13.3.1 Introduction

The timer consists of a 16-bit free-running counter driven by a programmable prescaler.

It may be used for a variety of purposes, including measuring the pulse lengths of up to two input signals (*input capture*) or generating up to two output waveforms (*output compare* and *PWM*).

Pulse lengths and waveform periods can be modulated from a few microseconds to several milliseconds using the timer prescaler and the CPU clock prescaler.

Some ST7 devices have two on-chip 16-bit timers. They are completely independent, and do not share any resources. They are synchronized after a MCU reset as long as the timer clock frequencies are not modified.

This description covers one or two 16-bit timers. In ST7 devices with two timers, register names are prefixed with TA (Timer A) or TB (Timer B).

13.3.2 Main Features

- Programmable prescaler: f_{CPU} divided by 2, 4 or 8
- Overflow status flag and maskable interrupt
- External clock input (must be at least 4 times slower than the CPU clock speed) with the choice of active edge
- Output compare functions with:
 - 2 dedicated 16-bit registers
 - 2 dedicated programmable signals
 - 2 dedicated status flags
 - 1 dedicated maskable interrupt
- Input capture functions with:
 - 2 dedicated 16-bit registers
 - 2 dedicated active edge selection signals
 - 2 dedicated status flags
 - 1 dedicated maskable interrupt
- Pulse Width Modulation mode (PWM)
- One Pulse mode
- 5 alternate functions on I/O ports (ICAP1, ICAP2, OCMP1, OCMP2, EXTCLK)*

The Block Diagram is shown in [Figure 30](#).

***Note:** Some timer pins may not be available (not bonded) in some ST7 devices. Refer to the device pin out description.

When reading an input signal on a non-bonded pin, the value will always be '1'.

13.3.3 Functional Description

13.3.3.1 Counter

The main block of the Programmable Timer is a 16-bit free running upcounter and its associated 16-bit registers. The 16-bit registers are made up of two 8-bit registers called high and low.

Counter Register (CR)

- Counter High Register (CHR) is the most significant byte (MS Byte).
- Counter Low Register (CLR) is the least significant byte (LS Byte).

Alternate Counter Register (ACR)

- Alternate Counter High Register (ACHR) is the most significant byte (MS Byte).
- Alternate Counter Low Register (ACLR) is the least significant byte (LS Byte).

These two read-only 16-bit registers contain the same value but with the difference that reading the ACLR register does not clear the TOF bit (Timer overflow flag), located in the Status register (SR). (See note at the end of paragraph titled 16-bit read sequence).

Writing in the CLR register or ACLR register resets the free running counter to the FFFCh value.

Both counters have a reset value of FFFCh (this is the only value which is reloaded in the 16-bit timer). The reset value of both counters is also FFFCh in One Pulse mode and PWM mode.

The timer clock depends on the clock control bits of the CR2 register, as illustrated in [Table 15 Clock Control Bits](#). The value in the counter register repeats every 131072, 262144 or 524288 CPU clock cycles depending on the CC[1:0] bits.

The timer frequency can be $f_{CPU}/2$, $f_{CPU}/4$, $f_{CPU}/8$ or an external frequency.

16-BIT TIMER (Cont'd)

16-bit Read Sequence: (from either the Counter Register or the Alternate Counter Register).

Beginning of the sequence

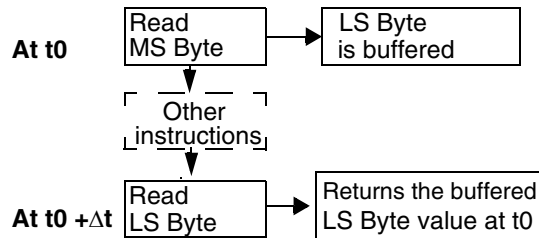

Sequence completed

The user must read the MS Byte first, then the LS Byte value is buffered automatically.

This buffered value remains unchanged until the 16-bit read sequence is completed, even if the user reads the MS Byte several times.

After a complete reading sequence, if only the CLR register or ACLR register are read, they return the LS Byte of the count value at the time of the read.

Whatever the timer mode used (input capture, output compare, One Pulse mode or PWM mode) an overflow occurs when the counter rolls over from FFFFh to 0000h then:

- The TOF bit of the SR register is set.
- A timer interrupt is generated if:
 - TOIE bit of the CR1 register is set and
 - I bit of the CC register is cleared.

If one of these conditions is false, the interrupt remains pending to be issued as soon as they are both true.

Clearing the overflow interrupt request is done in two steps:

1. Reading the SR register while the TOF bit is set.
2. An access (read or write) to the CLR register.

Note: The TOF bit is not cleared by accessing the ACLR register. The advantage of accessing the ACLR register rather than the CLR register is that it allows simultaneous use of the overflow function and reading the free running counter at random times (for example, to measure elapsed time) without the risk of clearing the TOF bit erroneously.

The timer is not affected by Wait mode.

In Halt mode, the counter stops counting until the mode is exited. Counting then resumes from the previous count (MCU awakened by an interrupt) or from the reset count (MCU awakened by a Reset).

13.3.3.2 External Clock

The external clock (where available) is selected if CC0 = 1 and CC1 = 1 in the CR2 register.

The status of the EXEDG bit in the CR2 register determines the type of level transition on the external clock pin EXTCLK that will trigger the free running counter.

The counter is synchronized with the falling edge of the internal CPU clock.

A minimum of four falling edges of the CPU clock must occur between two consecutive active edges of the external clock; thus the external clock frequency must be less than a quarter of the CPU clock frequency.

16-BIT TIMER (Cont'd)

Figure 31. Counter Timing Diagram, internal clock divided by 2

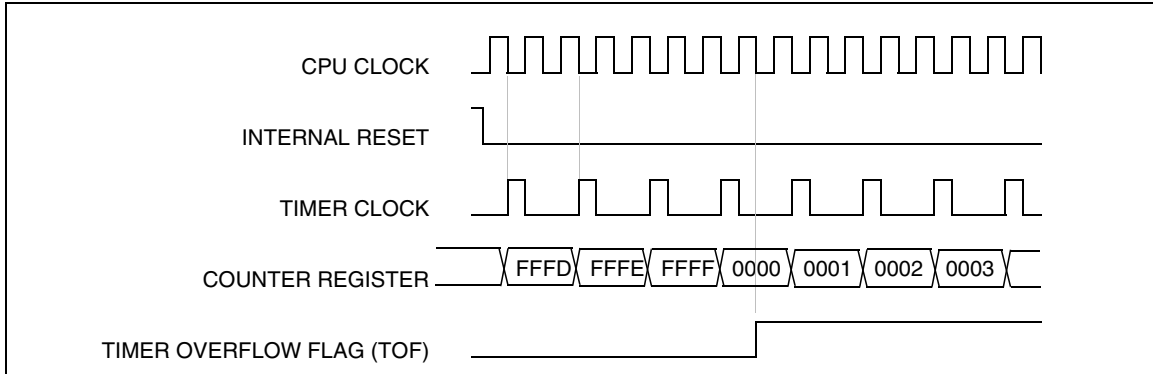

Figure 32. Counter Timing Diagram, internal clock divided by 4

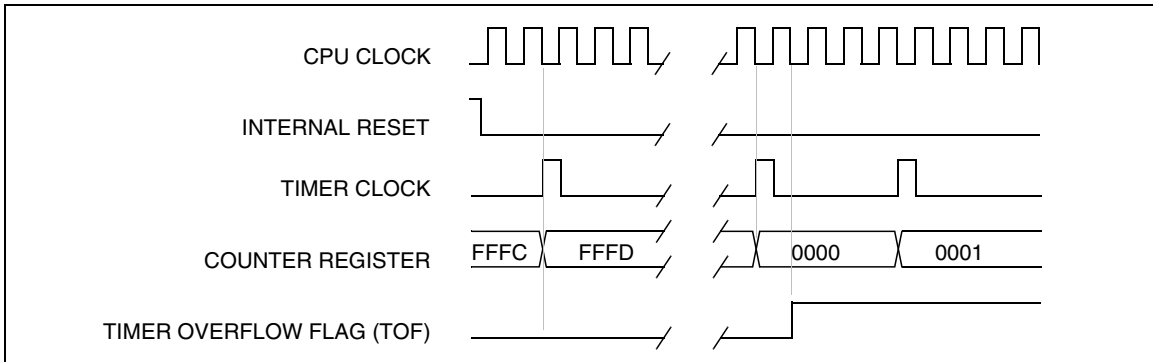
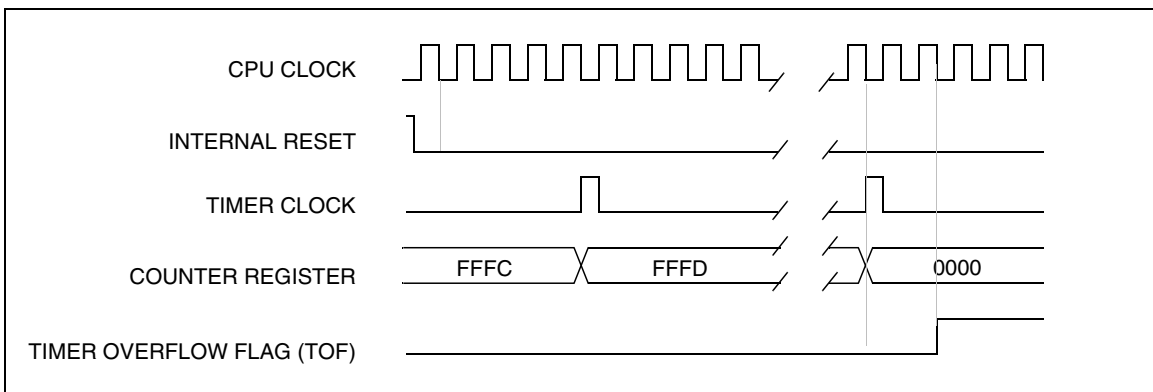

Figure 33. Counter Timing Diagram, internal clock divided by 8



Note: The MCU is in reset state when the internal reset signal is high. When it is low, the MCU is running.

16-BIT TIMER (Cont'd)

13.3.3.3 Input Capture

In this section, the index, *i*, may be 1 or 2 because there are two input capture functions in the 16-bit timer.

The two input capture 16-bit registers (IC1R and IC2R) are used to latch the value of the free running counter after a transition is detected by the ICAP*i* pin (see Figure 34).

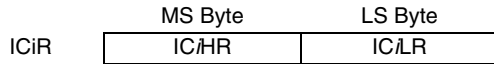

The ICiR register is a read-only register.

The active transition is software programmable through the IEDG*i* bit of Control Registers (CR*i*).

Timing resolution is one count of the free running counter: ($f_{CPU}/CC[1:0]$).

Procedure:

To use the input capture function, select the following in the CR2 register:

- Select the timer clock (CC[1:0]) (see Table 15 Clock Control Bits).
- Select the edge of the active transition on the ICAP2 pin with the IEDG2 bit (the ICAP2 pin must be configured as a floating input or input with pull-up without interrupt if this configuration is available).

And select the following in the CR1 register:

- Set the ICIE bit to generate an interrupt after an input capture coming from either the ICAP1 pin or the ICAP2 pin
- Select the edge of the active transition on the ICAP1 pin with the IEDG1 bit (the ICAP1 pin must be configured as a floating input or input with pull-up without interrupt if this configuration is available).

When an input capture occurs:

- The ICF*i* bit is set.
- The ICiR register contains the value of the free running counter on the active transition on the ICAP*i* pin (see Figure 35).
- A timer interrupt is generated if the ICIE bit is set and the I bit is cleared in the CC register. Otherwise, the interrupt remains pending until both conditions become true.

Clearing the Input Capture interrupt request (i.e. clearing the ICF*i* bit) is done in two steps:

1. Reading the SR register while the ICF*i* bit is set.
2. An access (read or write) to the ICiLR register.

Notes:

1. After reading the ICiHR register, the transfer of input capture data is inhibited and ICF*i* will never be set until the ICiLR register is also read.
2. The ICiR register contains the free running counter value which corresponds to the most recent input capture.
3. The two input capture functions can be used together even if the timer also uses the two output compare functions.
4. In One Pulse mode and PWM mode only the input capture 2 function can be used.
5. The alternate inputs (ICAP1 and ICAP2) are always directly connected to the timer. So any transitions on these pins activate the input capture function.
Moreover if one of the ICAP*i* pin is configured as an input and the second one as an output, an interrupt can be generated if the user toggles the output pin and if the ICIE bit is set. This can be avoided if the input capture function *i* is disabled by reading the ICiHR (see note 1).
6. The TOF bit can be used with an interrupt in order to measure events that exceed the timer range (FFFFh).

16-BIT TIMER (Cont'd)

Figure 34. Input Capture Block Diagram

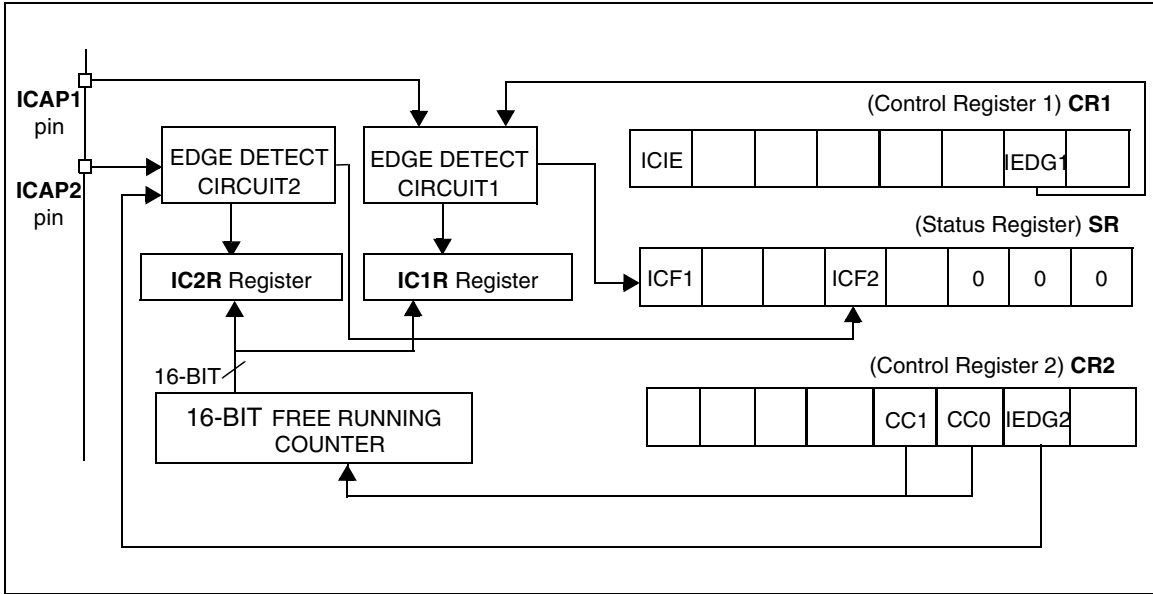
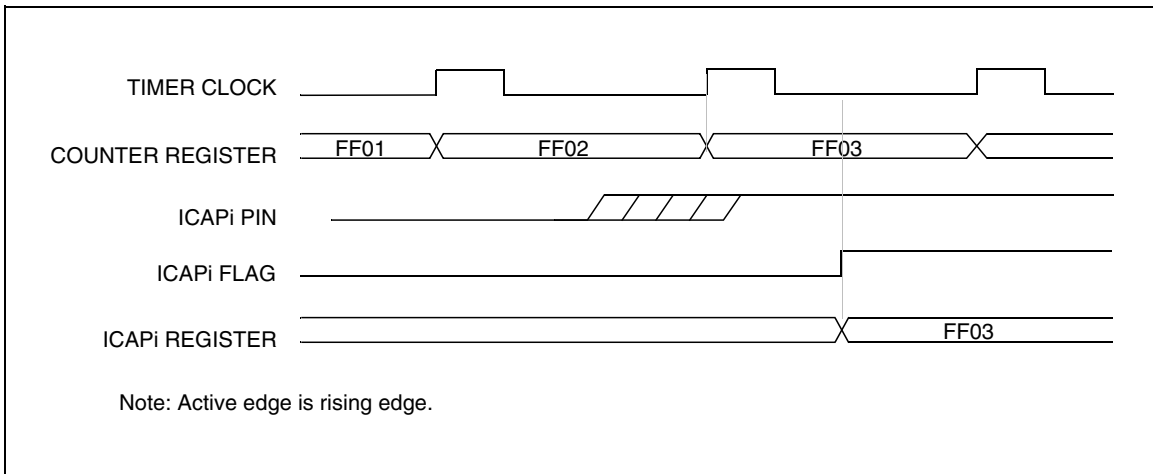

Figure 35. Input Capture Timing Diagram



16-BIT TIMER (Cont'd)

13.3.3.4 Output Compare

In this section, the index, *i*, may be 1 or 2 because there are two output compare functions in the 16-bit timer.

This function can be used to control an output waveform or indicate when a period of time has elapsed.

When a match is found between the Output Compare register and the free running counter, the output compare function:

- Assigns pins with a programmable value if the OC \bar{E} bit is set
- Sets a flag in the status register
- Generates an interrupt if enabled

Two 16-bit registers Output Compare Register 1 (OC1R) and Output Compare Register 2 (OC2R) contain the value to be compared to the counter register each timer clock cycle.

	MS Byte	LS Byte
OC \bar{R}	OC $\bar{H}R$	OC $\bar{L}R$

These registers are readable and writable and are not affected by the timer hardware. A reset event changes the OC \bar{R} value to 8000h.

Timing resolution is one count of the free running counter: ($f_{CPU}/CC[1:0]$).

Procedure:

To use the output compare function, select the following in the CR2 register:

- Set the OC \bar{E} bit if an output is needed then the OCMP \bar{i} pin is dedicated to the output compare *i* signal.
- Select the timer clock (CC[1:0]) (see [Table 15 Clock Control Bits](#)).

And select the following in the CR1 register:

- Select the OLVL \bar{i} bit to applied to the OCMP \bar{i} pins after the match occurs.
- Set the OCIE bit to generate an interrupt if it is needed.

When a match is found between OCR \bar{i} register and CR register:

- OCF \bar{i} bit is set.

- The OCMP \bar{i} pin takes OLVL \bar{i} bit value (OCMP \bar{i} pin latch is forced low during reset).
- A timer interrupt is generated if the OCIE bit is set in the CR1 register and the I bit is cleared in the CC register (CC).

The OC \bar{R} register value required for a specific timing application can be calculated using the following formula:

$$\Delta OC\bar{R} = \frac{\Delta t * f_{CPU}}{PRESC}$$

Where:

- Δt = Output compare period (in seconds)
- f_{CPU} = CPU clock frequency (in hertz)
- PRESC = Timer prescaler factor (2, 4 or 8 depending on CC[1:0] bits, see [Table 15 Clock Control Bits](#))

If the timer clock is an external clock, the formula is:

$$\Delta OC\bar{R} = \Delta t * f_{EXT}$$

Where:

- Δt = Output compare period (in seconds)
- f_{EXT} = External timer clock frequency (in hertz)

Clearing the output compare interrupt request (i.e. clearing the OCF \bar{i} bit) is done by:

1. Reading the SR register while the OCF \bar{i} bit is set.
2. An access (read or write) to the OC $\bar{L}R$ register. The following procedure is recommended to prevent the OCF \bar{i} bit from being set between the time it is read and the write to the OC \bar{R} register:
 - Write to the OC $\bar{H}R$ register (further compares are inhibited).
 - Read the SR register (first step of the clearance of the OCF \bar{i} bit, which may be already set).
 - Write to the OC $\bar{L}R$ register (enables the output compare function and clears the OCF \bar{i} bit).

16-BIT TIMER (Cont'd)

Notes:

1. After a processor write cycle to the OCiHR register, the output compare function is inhibited until the OCiLR register is also written.
2. If the OCiE bit is not set, the OCMPi pin is a general I/O port and the OLVLi bit will not appear when a match is found but an interrupt could be generated if the OCIE bit is set.
3. When the timer clock is $f_{CPU}/2$, OCFi and OCMPi are set while the counter value equals the OCiR register value (see Figure 37 on page 63). This behavior is the same in OPM or PWM mode.
When the timer clock is $f_{CPU}/4$, $f_{CPU}/8$ or in external clock mode, OCFi and OCMPi are set while the counter value equals the OCiR register value plus 1 (see Figure 38 on page 63).
4. The output compare functions can be used both for generating external events on the OCMPi pins even if the input capture mode is also used.
5. The value in the 16-bit OCiR register and the OLVi bit should be changed after each successful comparison in order to control an output waveform or establish a new elapsed timeout.

Forced Compare Output capability

When the FOLVi bit is set by software, the OLVLi bit is copied to the OCMPi pin. The OLVi bit has to be toggled in order to toggle the OCMPi pin when it is enabled (OCiE bit = 1). The OCFi bit is then not set by hardware, and thus no interrupt request is generated.

FOLVLi bits have no effect in either One Pulse mode or PWM mode.

Figure 36. Output Compare Block Diagram

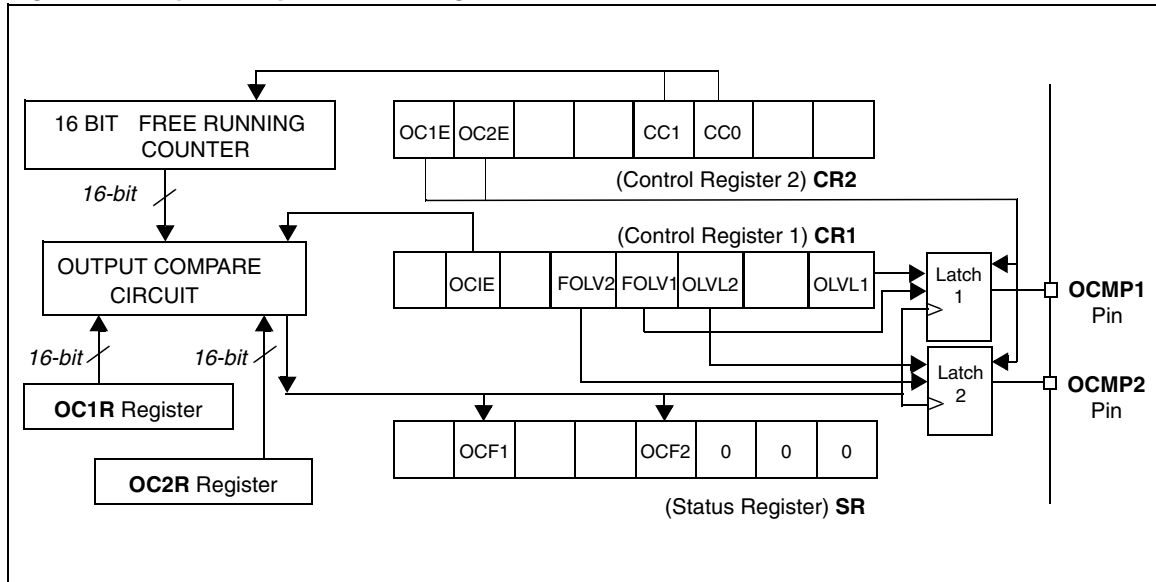

16-BIT TIMER (Cont'd)

Figure 37. Output Compare Timing Diagram, $f_{\text{TIMER}} = f_{\text{CPU}}/2$

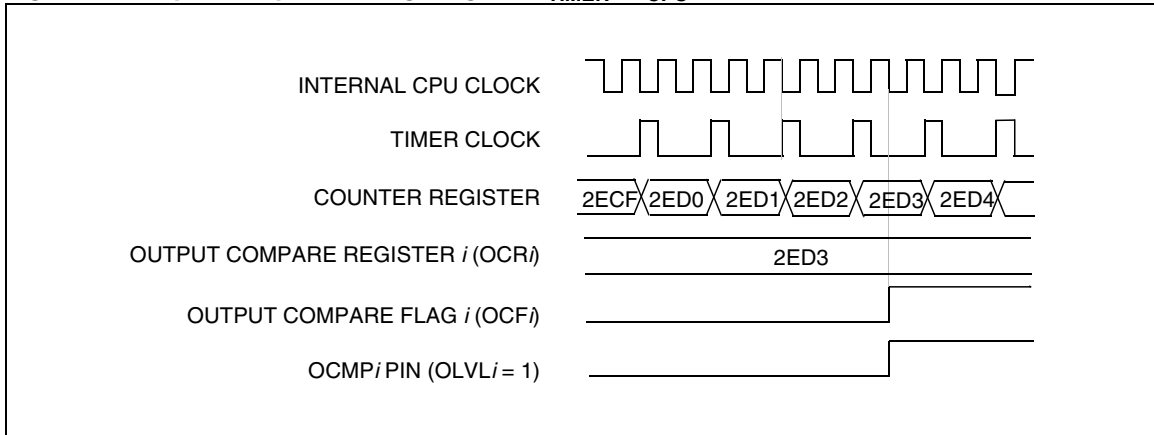
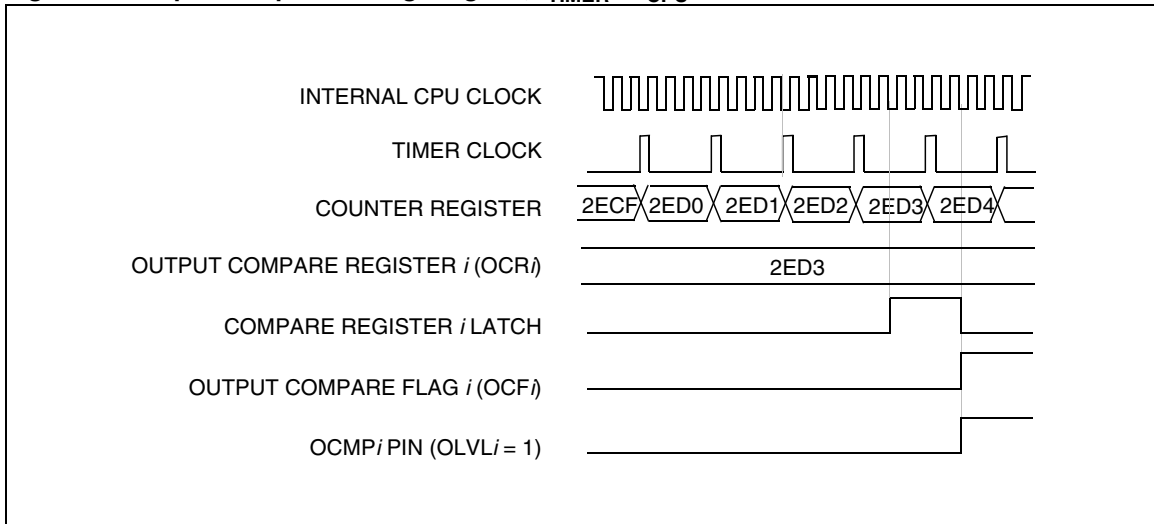

Figure 38. Output Compare Timing Diagram, $f_{\text{TIMER}} = f_{\text{CPU}}/4$



16-BIT TIMER (Cont'd)

13.3.3.5 One Pulse Mode

One Pulse mode enables the generation of a pulse when an external event occurs. This mode is selected via the OPM bit in the CR2 register.

The One Pulse mode uses the Input Capture1 function and the Output Compare1 function.

Procedure:

To use One Pulse mode:

1. Load the OC1R register with the value corresponding to the length of the pulse (see the formula in the opposite column).
2. Select the following in the CR1 register:
 - Using the OLVL1 bit, select the level to be applied to the OCMP1 pin after the pulse.
 - Using the OLVL2 bit, select the level to be applied to the OCMP1 pin during the pulse.
 - Select the edge of the active transition on the ICAP1 pin with the IEDG1 bit (the ICAP1 pin must be configured as floating input).
3. Select the following in the CR2 register:
 - Set the OC1E bit, the OCMP1 pin is then dedicated to the Output Compare 1 function.
 - Set the OPM bit.
 - Select the timer clock CC[1:0] (see [Table 15 Clock Control Bits](#)).

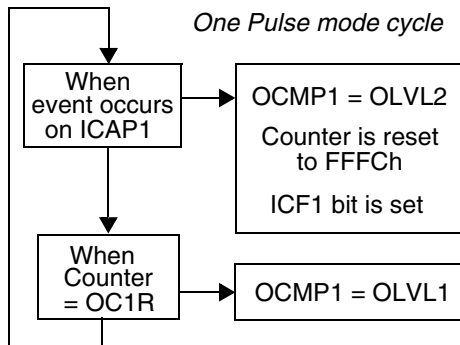

Then, on a valid event on the ICAP1 pin, the counter is initialized to FFFCh and the OLVL2 bit is loaded on the OCMP1 pin, the ICF1 bit is set and the value FFFDh is loaded in the IC1R register.

Because the ICF1 bit is set when an active edge occurs, an interrupt can be generated if the ICIE bit is set.

Clearing the Input Capture interrupt request (i.e. clearing the ICF1 bit) is done in two steps:

1. Reading the SR register while the ICF1 bit is set.
2. An access (read or write) to the IC1LR register.

The OC1R register value required for a specific timing application can be calculated using the following formula:

$$OC1R \text{ Value} = \frac{t \cdot f_{CPU}}{PRESC} - 5$$

Where:

t = Pulse period (in seconds)

f_{CPU} = CPU clock frequency (in hertz)

PRESC = Timer prescaler factor (2, 4 or 8 depending on the CC[1:0] bits, see [Table 15 Clock Control Bits](#))

If the timer clock is an external clock the formula is:

$$OC1R = t \cdot f_{EXT} - 5$$

Where:

t = Pulse period (in seconds)

f_{EXT} = External timer clock frequency (in hertz)

When the value of the counter is equal to the value of the contents of the OC1R register, the OLVL1 bit is output on the OCMP1 pin (see [Figure 39](#)).

Notes:

1. The OCF1 bit cannot be set by hardware in One Pulse mode but the OCF2 bit can generate an Output Compare interrupt.
2. When the Pulse Width Modulation (PWM) and One Pulse mode (OPM) bits are both set, the PWM mode is the only active one.
3. If OLVL1 = OLVL2 a continuous signal will be seen on the OCMP1 pin.
4. The ICAP1 pin can not be used to perform input capture. The ICAP2 pin can be used to perform input capture (ICF2 can be set and IC2R can be loaded) but the user must take care that the counter is reset each time a valid edge occurs on the ICAP1 pin and ICF1 can also generate interrupt if ICIE is set.
5. When One Pulse mode is used OC1R is dedicated to this mode. Nevertheless OC2R and OCF2 can be used to indicate that a period of time has elapsed but cannot generate an output waveform because the OLVL2 level is dedicated to One Pulse mode.

16-BIT TIMER (Cont'd)

Figure 39. One Pulse Mode Timing Example

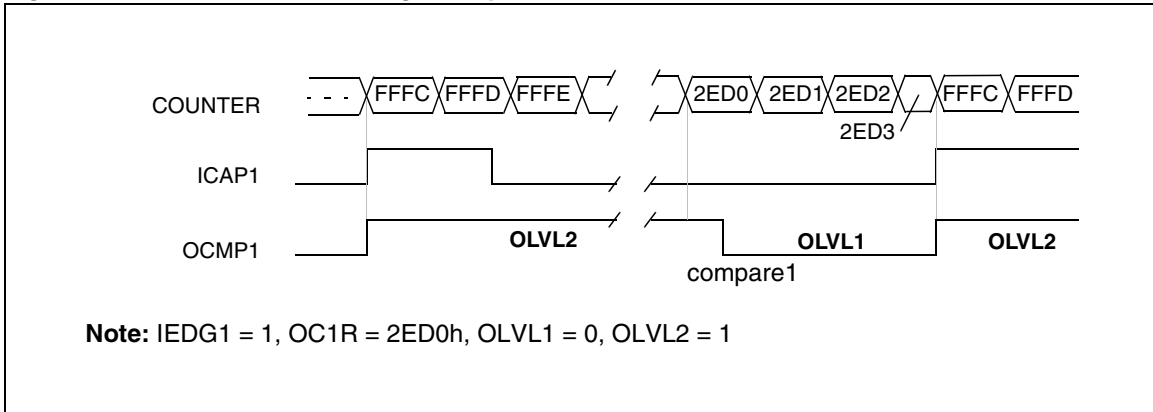
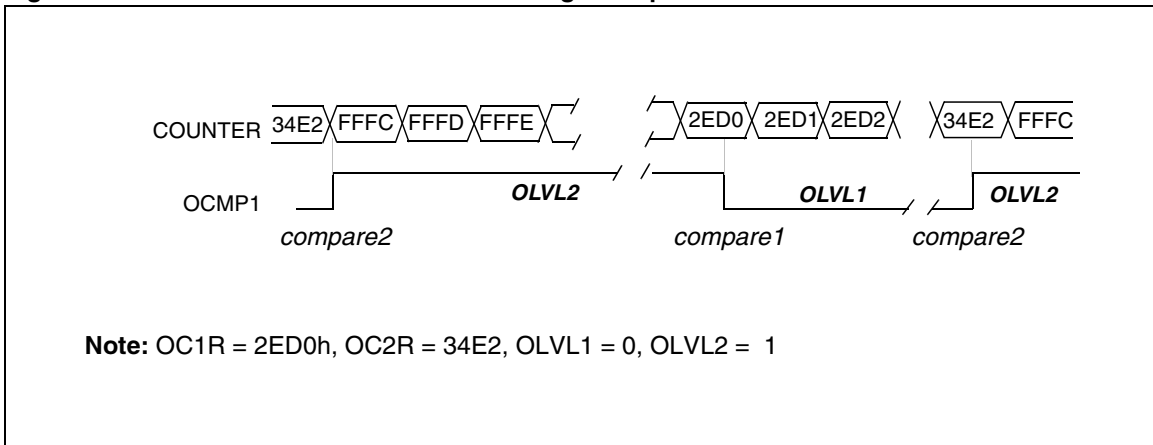

Figure 40. Pulse Width Modulation Mode Timing Example



16-BIT TIMER (Cont'd)

13.3.3.6 Pulse Width Modulation Mode

Pulse Width Modulation (PWM) mode enables the generation of a signal with a frequency and pulse length determined by the value of the OC1R and OC2R registers.

The Pulse Width Modulation mode uses the complete Output Compare 1 function plus the OC2R register, and so these functions cannot be used when the PWM mode is activated.

Procedure

To use Pulse Width Modulation mode:

1. Load the OC2R register with the value corresponding to the period of the signal using the formula in the opposite column.
2. Load the OC1R register with the value corresponding to the period of the pulse if OLVL1 = 0 and OLVL2 = 1, using the formula in the opposite column.
3. Select the following in the CR1 register:
 - Using the OLVL1 bit, select the level to be applied to the OCMP1 pin after a successful comparison with OC1R register.
 - Using the OLVL2 bit, select the level to be applied to the OCMP1 pin after a successful comparison with OC2R register.
4. Select the following in the CR2 register:
 - Set OC1E bit: the OCMP1 pin is then dedicated to the output compare 1 function.
 - Set the PWM bit.
 - Select the timer clock (CC[1:0]) (see [Table 15 Clock Control Bits](#)).

If OLVL1 = 1 and OLVL2 = 0, the length of the positive pulse is the difference between the OC2R and OC1R registers.

If OLVL1 = OLVL2 a continuous signal will be seen on the OCMP1 pin.

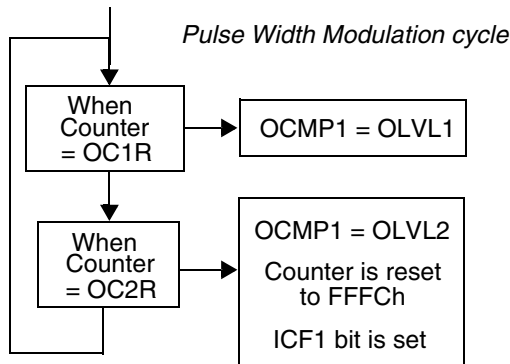

The OC/R register value required for a specific timing application can be calculated using the following formula:

$$OC/R \text{ Value} = \frac{t \cdot f_{CPU}}{PRESC} - 5$$

Where:

t = Signal or pulse period (in seconds)

f_{CPU} = CPU clock frequency (in hertz)

PRESC = Timer prescaler factor (2, 4 or 8 depending on CC[1:0] bits, see [Table 15 Clock Control Bits](#))

If the timer clock is an external clock the formula is:

$$OC/R = t \cdot f_{EXT} - 5$$

Where:

t = Signal or pulse period (in seconds)

f_{EXT} = External timer clock frequency (in hertz)

The Output Compare 2 event causes the counter to be initialized to FFFCh (See [Figure 40](#))

Notes:

1. After a write instruction to the OC/HR register, the output compare function is inhibited until the OC/LR register is also written.
2. The OCF1 and OCF2 bits cannot be set by hardware in PWM mode, therefore the Output Compare interrupt is inhibited.
3. The ICF1 bit is set by hardware when the counter reaches the OC2R value and can produce a timer interrupt if the ICIE bit is set and the I bit is cleared.
4. In PWM mode the ICAP1 pin can not be used to perform input capture because it is disconnected from the timer. The ICAP2 pin can be used to perform input capture (ICF2 can be set and IC2R can be loaded) but the user must take care that the counter is reset after each period and ICF1 can also generate an interrupt if ICIE is set.
5. When the Pulse Width Modulation (PWM) and One Pulse mode (OPM) bits are both set, the PWM mode is the only active one.

16-BIT TIMER (Cont'd)**13.3.4 Low Power Modes**

Mode	Description
WAIT	No effect on 16-bit Timer. Timer interrupts cause the device to exit from Wait mode.
HALT	16-bit Timer registers are frozen. In Halt mode, the counter stops counting until Halt mode is exited. Counting resumes from the previous count when the MCU is woken up by an interrupt with "exit from Halt mode" capability or from the counter reset value when the MCU is woken up by a RESET. If an input capture event occurs on the ICAP i pin, the input capture detection circuitry is armed. Consequently, when the MCU is woken up by an interrupt with "exit from Halt mode" capability, the ICF i bit is set, and the counter value present when exiting from Halt mode is captured into the IC i R register.

13.3.5 Interrupts

Interrupt Event	Event Flag	Enable Control Bit	Exit from Wait	Exit from Halt
Input Capture 1 event/Counter reset in PWM mode	ICF1	ICIE	Yes	No
Input Capture 2 event	ICF2		Yes	No
Output Compare 1 event (not available in PWM mode)	OCF1	OCIE	Yes	No
Output Compare 2 event (not available in PWM mode)	OCF2		Yes	No
Timer Overflow event	TOF	TOIE	Yes	No

Note: The 16-bit Timer interrupt events are connected to the same interrupt vector (see [INTERRUPTS](#) chapter). These events generate an interrupt if the corresponding Enable Control Bit is set and the interrupt mask in the CC register is reset (RIM instruction).

13.3.6 Summary of Timer modes

Modes	Available Resources			
	Input Capture 1	Input Capture 2	Output Compare 1	Output Compare 2
Input Capture (1 and/or 2)	Yes	Yes	Yes	Yes
Output Compare (1 and/or 2)	Yes	Yes	Yes	Yes
One Pulse mode	No	Not Recommended ¹⁾	No	Partially ²⁾
PWM Mode	No	Not Recommended ³⁾	No	No

Notes:

1. See note 4 in [Section 13.3.3.5 "One Pulse Mode" on page 64](#)
2. See note 5 in [Section 13.3.3.5 "One Pulse Mode" on page 64](#)
3. See note 4 in [Section 13.3.3.6 "Pulse Width Modulation Mode" on page 66](#)

16-BIT TIMER (Cont'd)

13.3.7 Register Description

Each Timer is associated with three control and status registers, and with six pairs of data registers (16-bit values) relating to the two input captures, the two output compares, the counter and the alternate counter.

CONTROL REGISTER 1 (CR1)

Read/Write

Reset Value: 0000 0000 (00h)

7							0
ICIE	OCIE	TOIE	FOLV2	FOLV1	OLVL2	IEDG1	OLVL1

Bit 7 = **ICIE** *Input Capture Interrupt Enable*.
 0: Interrupt is inhibited.
 1: A timer interrupt is generated whenever the ICF1 or ICF2 bit of the SR register is set.

Bit 6 = **OCIE** *Output Compare Interrupt Enable*.
 0: Interrupt is inhibited.
 1: A timer interrupt is generated whenever the OCF1 or OCF2 bit of the SR register is set.

Bit 5 = **TOIE** *Timer Overflow Interrupt Enable*.
 0: Interrupt is inhibited.
 1: A timer interrupt is enabled whenever the TOF bit of the SR register is set.

Bit 4 = **FOLV2** *Forced Output Compare 2*.
 This bit is set and cleared by software.
 0: No effect on the OCMP2 pin.
 1: Forces the OLVL2 bit to be copied to the OCMP2 pin, if the OC2E bit is set and even if there is no successful comparison.

Bit 3 = **FOLV1** *Forced Output Compare 1*.
 This bit is set and cleared by software.
 0: No effect on the OCMP1 pin.
 1: Forces OLVL1 to be copied to the OCMP1 pin, if the OC1E bit is set and even if there is no successful comparison.

Bit 2 = **OLVL2** *Output Level 2*.
 This bit is copied to the OCMP2 pin whenever a successful comparison occurs with the OC2R register and OCxE is set in the CR2 register. This value is copied to the OCMP1 pin in One Pulse mode and Pulse Width Modulation mode.

Bit 1 = **IEDG1** *Input Edge 1*.
 This bit determines which type of level transition on the ICAP1 pin will trigger the capture.
 0: A falling edge triggers the capture.
 1: A rising edge triggers the capture.

Bit 0 = **OLVL1** *Output Level 1*.
 The OLVL1 bit is copied to the OCMP1 pin whenever a successful comparison occurs with the OC1R register and the OC1E bit is set in the CR2 register.

16-BIT TIMER (Cont'd)

CONTROL REGISTER 2 (CR2)

Read/Write

Reset Value: 0000 0000 (00h)

7							0
OC1E	OC2E	OPM	PWM	CC1	CC0	IEDG2	EXEDG

Bit 7 = OC1E Output Compare 1 Pin Enable.
 This bit is used only to output the signal from the timer on the OCMP1 pin (OLV1 in Output Compare mode, both OLV1 and OLV2 in PWM and One Pulse mode). Whatever the value of the OC1E bit, the internal Output Compare 1 function of the timer remains active.
 0: OCMP1 pin alternate function disabled (I/O pin free for general-purpose I/O).
 1: OCMP1 pin alternate function enabled.

Bit 6 = OC2E Output Compare 2 Pin Enable.
 This bit is used only to output the signal from the timer on the OCMP2 pin (OLV2 in Output Compare mode). Whatever the value of the OC2E bit, the internal Output Compare 2 function of the timer remains active.
 0: OCMP2 pin alternate function disabled (I/O pin free for general-purpose I/O).
 1: OCMP2 pin alternate function enabled.

Bit 5 = OPM One Pulse mode.
 0: One Pulse mode is not active.
 1: One Pulse mode is active, the ICAP1 pin can be used to trigger one pulse on the OCMP1 pin; the active transition is given by the IEDG1 bit. The length of the generated pulse depends on the contents of the OC1R register.

Bit 4 = PWM Pulse Width Modulation.
 0: PWM mode is not active.
 1: PWM mode is active, the OCMP1 pin outputs a programmable cyclic signal; the length of the pulse depends on the value of OC1R register; the period depends on the value of OC2R register.

Bits 3:2 = CC[1:0] Clock Control.
 The timer clock mode depends on these bits:

Table 15. Clock Control Bits

Timer Clock	CC1	CC0
$f_{CPU} / 4$	0	0
$f_{CPU} / 2$	0	1
$f_{CPU} / 8$	1	0
External Clock (where available)	1	1

Note: If the external clock pin is not available, programming the external clock configuration stops the counter.

Bit 1 = IEDG2 Input Edge 2.
 This bit determines which type of level transition on the ICAP2 pin will trigger the capture.
 0: A falling edge triggers the capture.
 1: A rising edge triggers the capture.

Bit 0 = EXEDG External Clock Edge.
 This bit determines which type of level transition on the external clock pin (EXTCLK) will trigger the counter register.
 0: A falling edge triggers the counter register.
 1: A rising edge triggers the counter register.

16-BIT TIMER (Cont'd)

STATUS REGISTER (SR)

Read Only

Reset Value: 0000 0000 (00h)

The three least significant bits are not used.

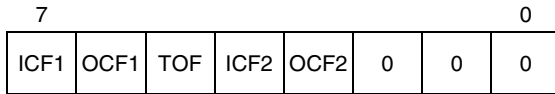

Bit 7 = **ICF1** *Input Capture Flag 1.*

0: No input capture (reset value).

1: An input capture has occurred on the ICAP1 pin or the counter has reached the OC2R value in PWM mode. To clear this bit, first read the SR register, then read or write the low byte of the IC1R (IC1LR) register.

Bit 6 = **OCF1** *Output Compare Flag 1.*

0: No match (reset value).

1: The content of the free running counter matches the content of the OC1R register. To clear this bit, first read the SR register, then read or write the low byte of the OC1R (OC1LR) register.

Bit 5 = **TOF** *Timer Overflow Flag.*

0: No timer overflow (reset value).

1: The free running counter has rolled over from FFFFh to 0000h. To clear this bit, first read the SR register, then read or write the low byte of the CR (CLR) register.

Note: Reading or writing the ACLR register does not clear TOF.

Bit 4 = **ICF2** *Input Capture Flag 2.*

0: No input capture (reset value).

1: An input capture has occurred on the ICAP2 pin. To clear this bit, first read the SR register, then read or write the low byte of the IC2R (IC2LR) register.

Bit 3 = **OCF2** *Output Compare Flag 2.*

0: No match (reset value).

1: The content of the free running counter matches the content of the OC2R register. To clear this bit, first read the SR register, then read or write the low byte of the OC2R (OC2LR) register.

Bit 2-0 = Reserved, forced by hardware to 0.

INPUT CAPTURE 1 HIGH REGISTER (IC1HR)

Read Only

Reset Value: Undefined

This is an 8-bit read only register that contains the high part of the counter value (transferred by the input capture 1 event).

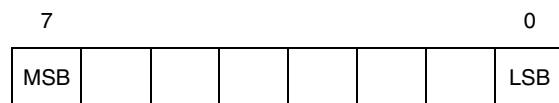

INPUT CAPTURE 1 LOW REGISTER (IC1LR)

Read Only

Reset Value: Undefined

This is an 8-bit read only register that contains the low part of the counter value (transferred by the input capture 1 event).



OUTPUT COMPARE 1 HIGH REGISTER (OC1HR)

Read/Write

Reset Value: 1000 0000 (80h)

This is an 8-bit register that contains the high part of the value to be compared to the CHR register.

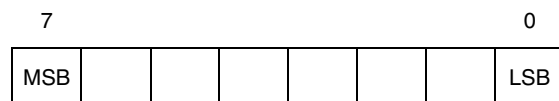

OUTPUT COMPARE 1 LOW REGISTER (OC1LR)

Read/Write

Reset Value: 0000 0000 (00h)

This is an 8-bit register that contains the low part of the value to be compared to the CLR register.



16-BIT TIMER (Cont'd)

OUTPUT COMPARE 2 HIGH REGISTER (OC2HR)

Read/Write
Reset Value: 1000 0000 (80h)

This is an 8-bit register that contains the high part of the value to be compared to the CHR register.



ALTERNATE COUNTER HIGH REGISTER (ACHR)

Read Only
Reset Value: 1111 1111 (FFh)

This is an 8-bit register that contains the high part of the counter value.

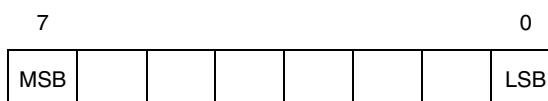

OUTPUT COMPARE 2 LOW REGISTER (OC2LR)

Read/Write
Reset Value: 0000 0000 (00h)

This is an 8-bit register that contains the low part of the value to be compared to the CLR register.

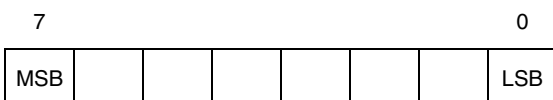

ALTERNATE COUNTER LOW REGISTER (ACLRL)

Read Only
Reset Value: 1111 1100 (FCh)

This is an 8-bit register that contains the low part of the counter value. A write to this register resets the counter. An access to this register after an access to SR register does not clear the TOF bit in SR register.



COUNTER HIGH REGISTER (CHR)

Read Only
Reset Value: 1111 1111 (FFh)

This is an 8-bit register that contains the high part of the counter value.



INPUT CAPTURE 2 HIGH REGISTER (IC2HR)

Read Only
Reset Value: Undefined

This is an 8-bit read only register that contains the high part of the counter value (transferred by the Input Capture 2 event).

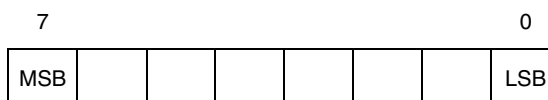

COUNTER LOW REGISTER (CLR)

Read Only
Reset Value: 1111 1100 (FCh)

This is an 8-bit register that contains the low part of the counter value. A write to this register resets the counter. An access to this register after accessing the SR register clears the TOF bit.



INPUT CAPTURE 2 LOW REGISTER (IC2LR)

Read Only
Reset Value: Undefined

This is an 8-bit read only register that contains the low part of the counter value (transferred by the Input Capture 2 event).



16-BIT TIMER (Cont'd)

Table 16. 16-Bit Timer Register Map and Reset Values

Address (Hex.)	Register Label	7	6	5	4	3	2	1	0
Timer A: 32 Timer B: 42	CR1 Reset Value	ICIE 0	OCIE 0	TOIE 0	FOLV2 0	FOLV1 0	OLVL2 0	IEDG1 0	OLVL1 0
Timer A: 31 Timer B: 41	CR2 Reset Value	OC1E 0	OC2E 0	OPM 0	PWM 0	CC1 0	CC0 0	IEDG2 0	EXEDG 0
Timer A: 33 Timer B: 43	SR Reset Value	ICF1 0	OCF1 0	TOF 0	ICF2 0	OCF2 0	- 0	- 0	- 0
Timer A: 34 Timer B: 44	ICHR1 Reset Value	MSB -	-	-	-	-	-	-	LSB -
Timer A: 35 Timer B: 45	ICLR1 Reset Value	MSB -	-	-	-	-	-	-	LSB -
Timer A: 36 Timer B: 46	OCHR1 Reset Value	MSB -	-	-	-	-	-	-	LSB -
Timer A: 37 Timer B: 47	OCLR1 Reset Value	MSB -	-	-	-	-	-	-	LSB -
Timer A: 3E Timer B: 4E	OCHR2 Reset Value	MSB -	-	-	-	-	-	-	LSB -
Timer A: 3F Timer B: 4F	OCLR2 Reset Value	MSB -	-	-	-	-	-	-	LSB -
Timer A: 38 Timer B: 48	CHR Reset Value	MSB 1	1	1	1	1	1	1	LSB 1
Timer A: 39 Timer B: 49	CLR Reset Value	MSB 1	1	1	1	1	1	0	LSB 0
Timer A: 3A Timer B: 4A	ACHR Reset Value	MSB 1	1	1	1	1	1	1	LSB 1
Timer A: 3B Timer B: 4B	ACLR Reset Value	MSB 1	1	1	1	1	1	0	LSB 0
Timer A: 3C Timer B: 4C	ICHR2 Reset Value	MSB -	-	-	-	-	-	-	LSB -
Timer A: 3D Timer B: 4D	ICLR2 Reset Value	MSB -	-	-	-	-	-	-	LSB -

13.4 SERIAL PERIPHERAL INTERFACE (SPI)

13.4.1 Introduction

The Serial Peripheral Interface (SPI) allows full-duplex, synchronous, serial communication with external devices. An SPI system may consist of a master and one or more slaves or a system in which devices may be either masters or slaves.

The SPI is normally used for communication between the microcontroller and external peripherals or another microcontroller.

Refer to the [PIN DESCRIPTION](#) chapter for the device-specific pinout.

13.4.2 Main Features

- Full duplex, three-wire synchronous transfers
- Master or slave operation
- 4 master mode frequencies
- Maximum slave mode frequency = $f_{CPU}/4$
- 4 programmable master bit rates
- Programmable clock polarity and phase
- End of transfer interrupt flag
- Write collision flag protection
- Master mode fault protection capability

13.4.3 General description

The SPI is connected to external devices through four alternate pins:

- MISO: Master In Slave Out pin
- MOSI: Master Out Slave In pin
- SCK: Serial Clock pin
- \overline{SS} : Slave select pin

A basic example of interconnections between a single master and a single slave is illustrated on [Figure 41](#).

The MOSI pins are connected together as are MISO pins. In this way data is transferred serially between master and slave (most significant bit first).

When the master device transmits data to a slave device via MOSI pin, the slave device responds by sending data to the master device via the MISO pin. This implies full duplex transmission with both data out and data in synchronized with the same clock signal (which is provided by the master device via the SCK pin).

Thus, the byte transmitted is replaced by the byte received and eliminates the need for separate transmit-empty and receiver-full bits. A status flag is used to indicate that the I/O operation is complete.

Four possible data/clock timing relationships may be chosen (see [Figure 44](#)) but master and slave must be programmed with the same timing mode.

Figure 41. Serial Peripheral Interface Master/Slave

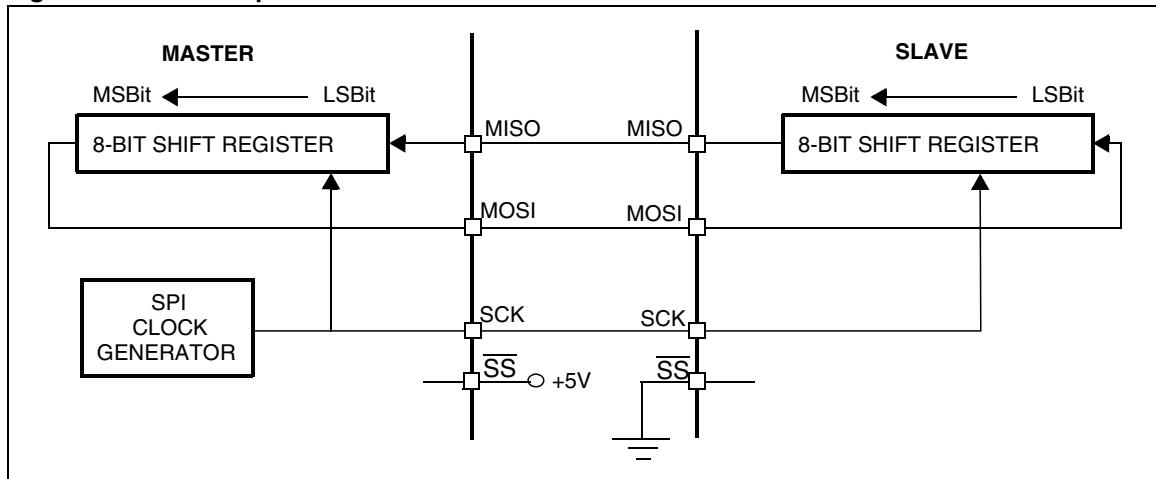

SERIAL PERIPHERAL INTERFACE (Cont'd)

Figure 42. Serial Peripheral Interface Block Diagram

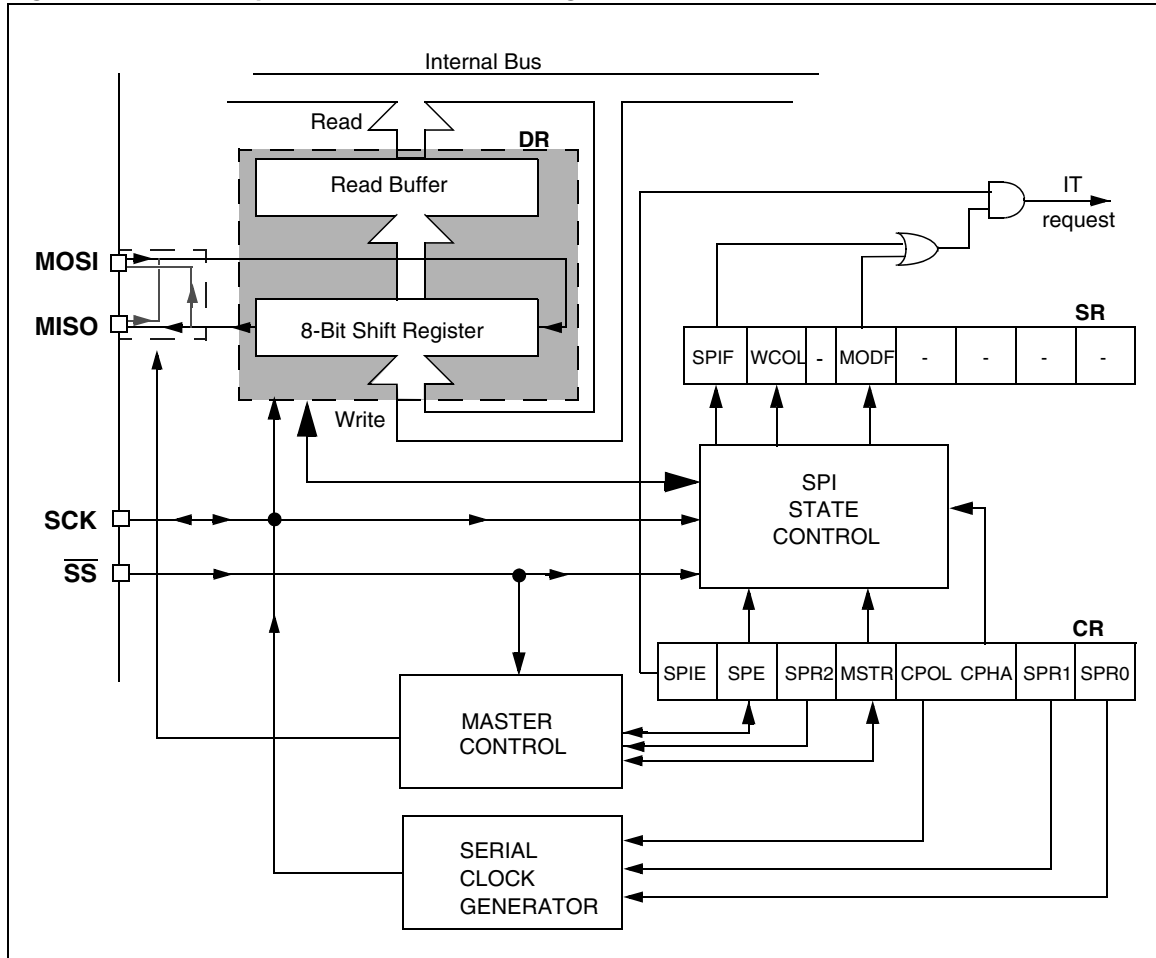

SERIAL PERIPHERAL INTERFACE (Cont'd)**13.4.4 Functional Description**

Figure 41 shows the serial peripheral interface (SPI) block diagram.

This interface contains three dedicated registers:

- A Control Register (CR)
- A Status Register (SR)
- A Data Register (DR)

Refer to the CR, SR and DR registers in Section 13.4.7 for the bit definitions.

13.4.4.1 Master Configuration

In a master configuration, the serial clock is generated on the SCK pin.

Procedure

- Select the SPR0 and SPR1 bits to define the serial clock baud rate (see CR register).
- Select the CPOL and CPHA bits to define one of the four relationships between the data transfer and the serial clock (see Figure 44).
- The \overline{SS} pin must be connected to a high level signal during the complete byte transmit sequence.
- The MSTR and SPE bits must be set (they remain set only if the \overline{SS} pin is connected to a high level signal).

In this configuration the MOSI pin is a data output and to the MISO pin is a data input.

Transmit sequence

The transmit sequence begins when a byte is written the DR register.

The data byte is parallel loaded into the 8-bit shift register (from the internal bus) during a write cycle and then shifted out serially to the MOSI pin most significant bit first.

When data transfer is complete:

- The SPIF bit is set by hardware
- An interrupt is generated if the SPIE bit is set and the I bit in the CCR register is cleared.

During the last clock cycle the SPIF bit is set, a copy of the data byte received in the shift register is moved to a buffer. When the DR register is read, the SPI peripheral returns this buffered value.

Clearing the SPIF bit is performed by the following software sequence:

1. An access to the SR register while the SPIF bit is set
2. A read to the DR register.

Note: While the SPIF bit is set, all writes to the DR register are inhibited until the SR register is read.

SERIAL PERIPHERAL INTERFACE (Cont'd)

13.4.4.2 Slave Configuration

In slave configuration, the serial clock is received on the SCK pin from the master device.

The value of the SPR0 and SPR1 bits is not used for the data transfer.

Procedure

- For correct data transfer, the slave device must be in the same timing mode as the master device (CPOL and CPHA bits). See [Figure 44](#).
- The \overline{SS} pin must be connected to a low level signal during the complete byte transmit sequence.
- Clear the MSTR bit and set the SPE bit to assign the pins to alternate function.

In this configuration the MOSI pin is a data input and the MISO pin is a data output.

Transmit Sequence

The data byte is parallel loaded into the 8-bit shift register (from the internal bus) during a write cycle and then shifted out serially to the MISO pin most significant bit first.

The transmit sequence begins when the slave device receives the clock signal and the most significant bit of the data on its MOSI pin.

When data transfer is complete:

- The SPIF bit is set by hardware
- An interrupt is generated if SPIE bit is set and I bit in CCR register is cleared.

During the last clock cycle the SPIF bit is set, a copy of the data byte received in the shift register is moved to a buffer. When the DR register is read, the SPI peripheral returns this buffered value.

Clearing the SPIF bit is performed by the following software sequence:

1. An access to the SR register while the SPIF bit is set.
2. A read to the DR register.

Notes: While the SPIF bit is set, all writes to the DR register are inhibited until the SR register is read.

The SPIF bit can be cleared during a second transmission; however, it must be cleared before the second SPIF bit in order to prevent an overrun condition (see [Section 13.4.4.6](#)).

Depending on the CPHA bit, the \overline{SS} pin has to be set to write to the DR register between each data byte transfer to avoid a write collision (see [Section 13.4.4.4](#)).

SERIAL PERIPHERAL INTERFACE (Cont'd)

13.4.4.3 Data Transfer Format

During an SPI transfer, data is simultaneously transmitted (shifted out serially) and received (shifted in serially). The serial clock is used to synchronize the data transfer during a sequence of eight clock pulses.

The \overline{SS} pin allows individual selection of a slave device; the other slave devices that are not selected do not interfere with the SPI transfer.

Clock Phase and Clock Polarity

Four possible timing relationships may be chosen by software, using the CPOL and CPHA bits.

The CPOL (clock polarity) bit controls the steady state value of the clock when no data is being transferred. This bit affects both master and slave modes.

The combination between the CPOL and CPHA (clock phase) bits selects the data capture clock edge.

Figure 44, shows an SPI transfer with the four combinations of the CPHA and CPOL bits. The diagram may be interpreted as a master or slave timing diagram where the SCK pin, the MISO pin, the MOSI pin are directly connected between the master and the slave device.

The \overline{SS} pin is the slave device select input and can be driven by the master device.

The master device applies data to its MOSI pin-clock edge before the capture clock edge.

CPHA bit is set

The second edge on the SCK pin (falling edge if the CPOL bit is reset, rising edge if the CPOL bit is set) is the MSBit capture strobe. Data is latched on the occurrence of the second clock transition.

No write collision should occur even if the \overline{SS} pin stays low during a transfer of several bytes (see Figure 43).

CPHA bit is reset

The first edge on the SCK pin (falling edge if CPOL bit is set, rising edge if CPOL bit is reset) is the MSBit capture strobe. Data is latched on the occurrence of the first clock transition.

The \overline{SS} pin must be toggled high and low between each byte transmitted (see Figure 43).

To protect the transmission from a write collision a low value on the \overline{SS} pin of a slave device freezes the data in its DR register and does not allow it to be altered. Therefore the \overline{SS} pin must be high to write a new data byte in the DR without producing a write collision.

Figure 43. CPHA / \overline{SS} Timing Diagram

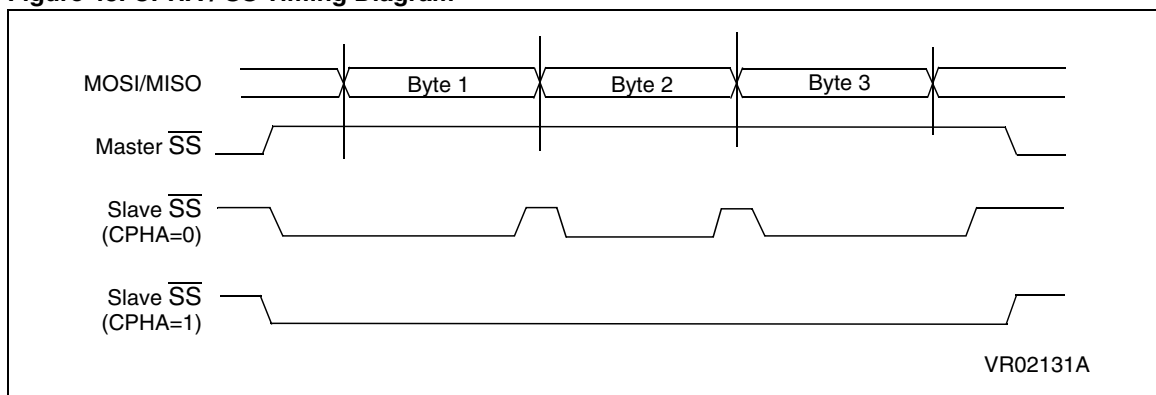

SERIAL PERIPHERAL INTERFACE (Cont'd)

Figure 44. Data Clock Timing Diagram

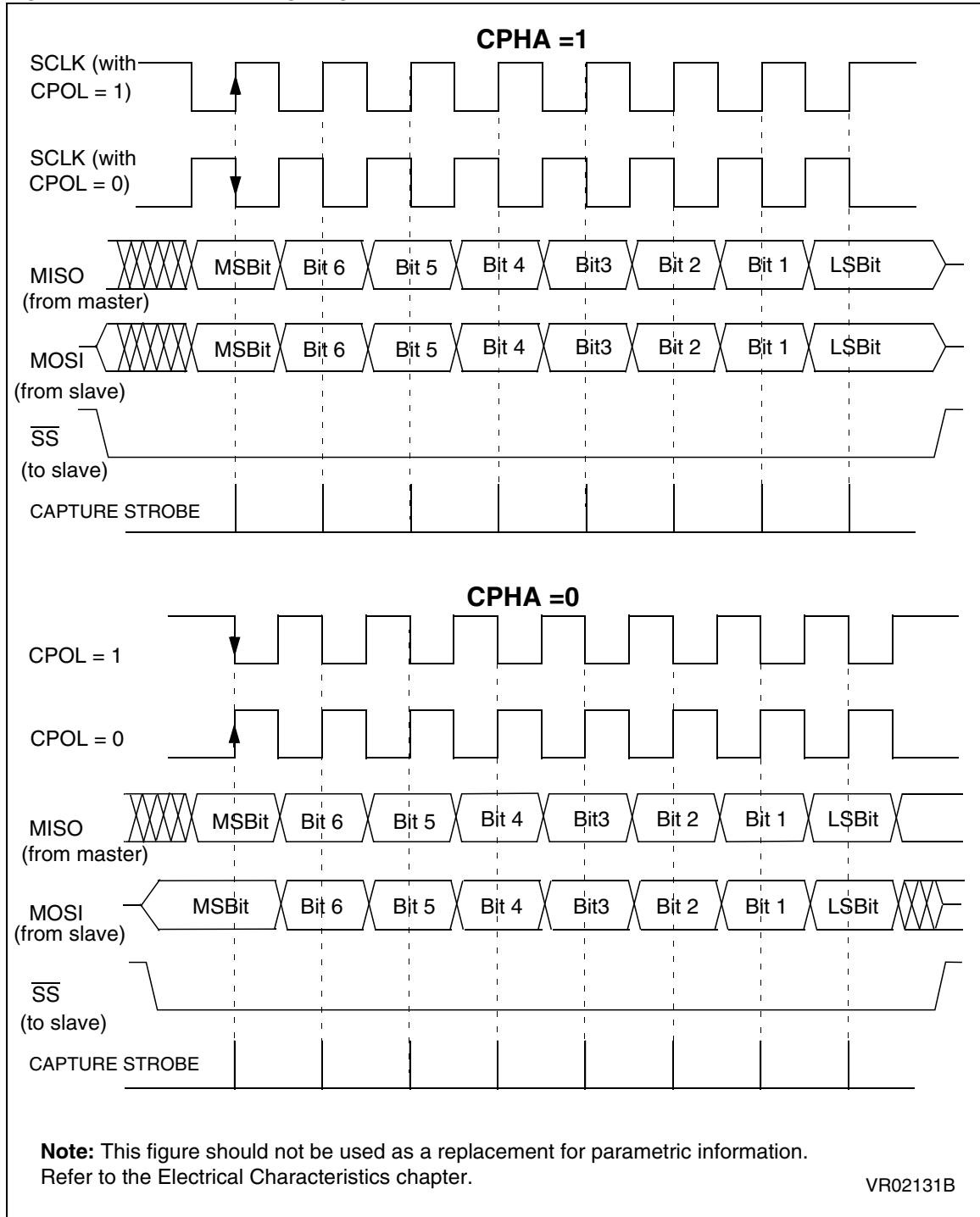

SERIAL PERIPHERAL INTERFACE (Cont'd)

13.4.4.4 Write Collision Error

A write collision occurs when the software tries to write to the DR register while a data transfer is taking place with an external device. When this happens, the transfer continues uninterrupted; and the software write will be unsuccessful.

Write collisions can occur both in master and slave mode.

Note: A “read collision” will never occur since the received data byte is placed in a buffer in which access is always synchronous with the MCU operation.

In Slave mode

When the CPHA bit is set:

The slave device will receive a clock (SCK) edge prior to the latch of the first data transfer. This first clock edge will freeze the data in the slave device DR register and output the MSBit on to the external MISO pin of the slave device.

The \overline{SS} pin low state enables the slave device but the output of the MSBit onto the MISO pin does not take place until the first data transfer clock edge.

When the CPHA bit is reset:

Data is latched on the occurrence of the first clock transition. The slave device does not have any way of knowing when that transition will occur; therefore, the slave device collision occurs when software attempts to write the DR register after its \overline{SS} pin has been pulled low.

For this reason, the \overline{SS} pin must be high, between each data byte transfer, to allow the CPU to write in the DR register without generating a write collision.

In Master mode

Collision in the master device is defined as a write of the DR register while the internal serial clock (SCK) is in the process of transfer.

The \overline{SS} pin signal must be always high on the master device.

WCOL bit

The WCOL bit in the SR register is set if a write collision occurs.

No SPI interrupt is generated when the WCOL bit is set (the WCOL bit is a status flag only).

Clearing the WCOL bit is done through a software sequence (see Figure 45).

Figure 45. Clearing the WCOL bit (Write Collision Flag) Software Sequence

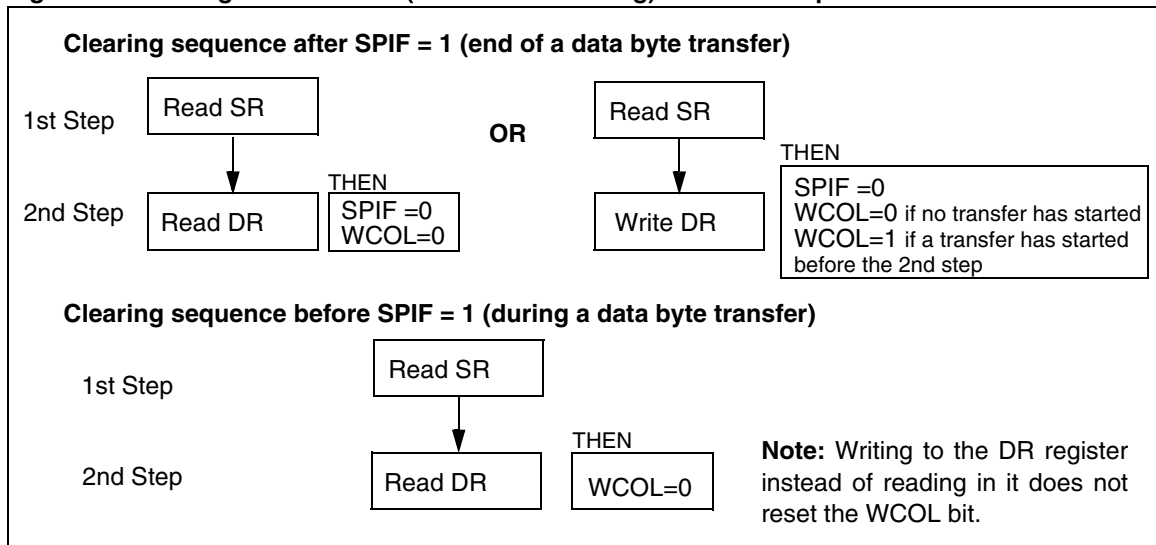

SERIAL PERIPHERAL INTERFACE (Cont'd)

13.4.4.5 Master Mode Fault

Master mode fault occurs when the master device has its \overline{SS} pin pulled low, then the MODF bit is set.

Master mode fault affects the SPI peripheral in the following ways:

- The MODF bit is set and an SPI interrupt is generated if the SPIE bit is set.
- The SPE bit is reset. This blocks all output from the device and disables the SPI peripheral.
- The MSTR bit is reset, thus forcing the device into slave mode.

Clearing the MODF bit is done through a software sequence:

1. A read or write access to the SR register while the MODF bit is set.
2. A write to the CR register.

Notes: To avoid any multiple slave conflicts in the case of a system comprising several MCUs, the \overline{SS} pin must be pulled high during the clearing sequence of the MODF bit. The SPE and MSTR bits

may be restored to their original state during or after this clearing sequence.

Hardware does not allow the user to set the SPE and MSTR bits while the MODF bit is set except in the MODF bit clearing sequence.

In a slave device the MODF bit can not be set, but in a multi master configuration the device can be in slave mode with this MODF bit set.

The MODF bit indicates that there might have been a multimaster conflict for system control and allows a proper exit from system operation to a reset or default system state using an interrupt routine.

13.4.4.6 Overrun Condition

An overrun condition occurs when the master device has sent several data bytes and the slave device has not cleared the SPIF bit issuing from the previous data byte transmitted.

In this case, the receiver buffer contains the byte sent after the SPIF bit was last cleared. A read to the DR register returns this byte. All other bytes are lost.

This condition is not detected by the SPI peripheral.

SERIAL PERIPHERAL INTERFACE (Cont'd)**13.4.4.7 Single Master and Multimaster Configurations**

There are two types of SPI systems:

- Single Master System
- Multimaster System

Single Master System

A typical single master system may be configured, using an MCU as the master and four MCUs as slaves (see Figure 46).

The master device selects the individual slave devices by using four pins of a parallel port to control the four \overline{SS} pins of the slave devices.

The \overline{SS} pins are pulled high during reset since the master device ports will be forced to be inputs at that time, thus disabling the slave devices.

Note: To prevent a bus conflict on the MISO line the master allows only one active slave device during a transmission.

For more security, the slave device may respond to the master with the received data byte. Then the master will receive the previous byte back from the slave device if all MISO and MOSI pins are connected and the slave has not written its DR register.

Other transmission security methods can use ports for handshake lines or data bytes with command fields.

Multimaster System

A multimaster system may also be configured by the user. Transfer of master control could be implemented using a handshake method through the I/O ports or by an exchange of code messages through the serial peripheral interface system.

The multi-master system is principally handled by the MSTR bit in the CR register and the MODF bit in the SR register.

Figure 46. Single Master Configuration

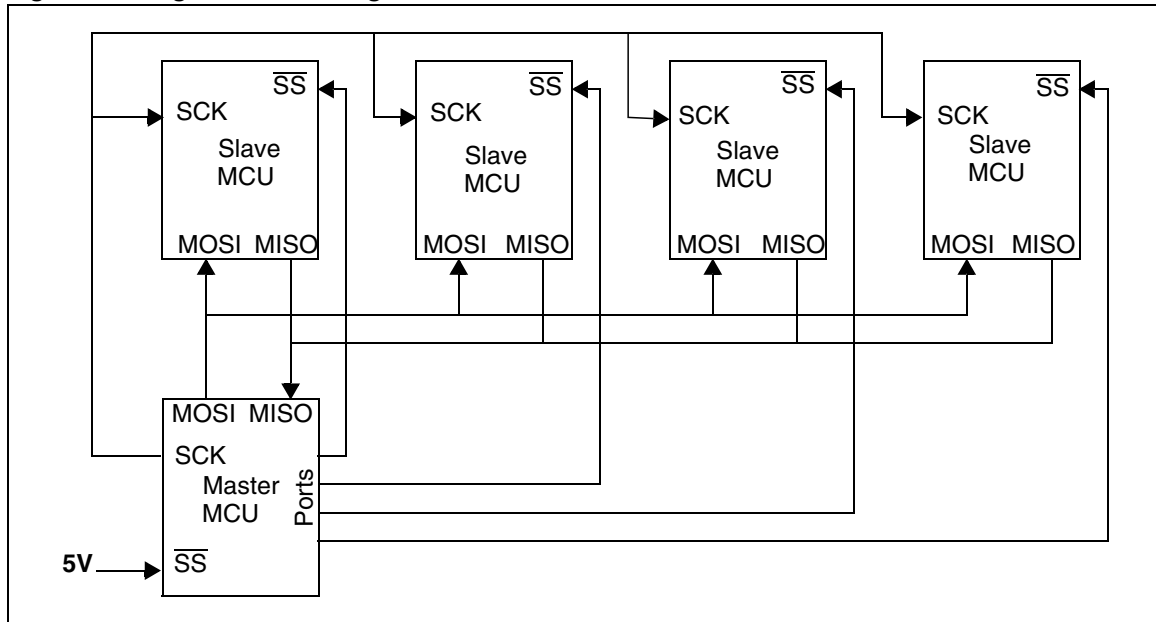

SERIAL PERIPHERAL INTERFACE (Cont'd)

13.4.5 Low Power Modes

Mode	Description
WAIT	No effect on SPI. SPI interrupt events cause the device to exit from Wait mode.
HALT	SPI registers are frozen. In Halt mode, the SPI is inactive. SPI operation resumes when the MCU is woken up by an interrupt with "exit from Halt mode" capability.

13.4.6 Interrupts

Interrupt Event	Event Flag	Enable Control Bit	Exit from Wait	Exit from Halt
SPI End of Transfer Event	SPIF	SPIE	Yes	No
Master Mode Fault Event	MODF		Yes	No

Note: The SPI interrupt events are connected to the same interrupt vector (see [INTERRUPTS](#) chapter). They generate an interrupt if the corresponding Enable Control Bit is set and the interrupt mask in

the CC register is reset (RIM instruction).

SERIAL PERIPHERAL INTERFACE (Cont'd)**13.4.7 Register Description****CONTROL REGISTER (CR)**

Read/Write

Reset Value: 0000xxxx (0xh)

7							0
SPIE	SPE	SPR2	MSTR	CPOL	CPHA	SPR1	SPR0

Bit 7 = **SPIE** *Serial peripheral interrupt enable.*

This bit is set and cleared by software.

0: Interrupt is inhibited

1: An SPI interrupt is generated whenever SPIF=1 or MODF=1 in the SR register

Bit 6 = **SPE** *Serial peripheral output enable.*

This bit is set and cleared by software. It is also cleared by hardware when, in master mode, $\overline{SS}=0$ (see [Section 13.4.4.5 "Master Mode Fault" on page 80](#)).

0: I/O port connected to pins

1: SPI alternate functions connected to pins

The SPE bit is cleared by reset, so the SPI peripheral is not initially connected to the external pins.

Bit 5 = **SPR2** *Divider Enable.*

this bit is set and cleared by software and it is cleared by reset. It is used with the SPR[1:0] bits to set the baud rate. Refer to [Table 17](#).

0: Divider by 2 enabled

1: Divider by 2 disabled

Bit 4 = **MSTR** *Master.*

This bit is set and cleared by software. It is also cleared by hardware when, in master mode, $\overline{SS}=0$ (see [Section 13.4.4.5 "Master Mode Fault" on page 80](#)).

0: Slave mode is selected

1: Master mode is selected, the function of the SCK pin changes from an input to an output and the functions of the MISO and MOSI pins are reversed.

Bit 3 = **CPOL** *Clock polarity.*

This bit is set and cleared by software. This bit determines the steady state of the serial Clock. The CPOL bit affects both the master and slave modes.

0: The steady state is a low value at the SCK pin.

1: The steady state is a high value at the SCK pin.

Bit 2 = **CPHA** *Clock phase.*

This bit is set and cleared by software.

0: The first clock transition is the first data capture edge.

1: The second clock transition is the first capture edge.

Bit 1:0 = **SPR[1:0]** *Serial peripheral rate.*

These bits are set and cleared by software. Used with the SPR2 bit, they select one of six baud rates to be used as the serial clock when the device is a master.

These 2 bits have no effect in slave mode.

Table 17. Serial Peripheral Baud Rate

Serial Clock	SPR2	SPR1	SPR0
$f_{CPU}/4$	1	0	0
$f_{CPU}/8$	0	0	0
$f_{CPU}/16$	0	0	1
$f_{CPU}/32$	1	1	0
$f_{CPU}/64$	0	1	0
$f_{CPU}/128$	0	1	1

SERIAL PERIPHERAL INTERFACE (Cont'd)

STATUS REGISTER (SR)

Read Only

Reset Value: 0000 0000 (00h)

7							0
SPIF	WCOL	-	MODF	-	-	-	-

Bit 7 = **SPIF** *Serial Peripheral data transfer flag.*
 This bit is set by hardware when a transfer has been completed. An interrupt is generated if SPIE=1 in the CR register. It is cleared by a software sequence (an access to the SR register followed by a read or write to the DR register).

0: Data transfer is in progress or has been approved by a clearing sequence.
 1: Data transfer between the device and an external device has been completed.

Note: While the SPIF bit is set, all writes to the DR register are inhibited.

Bit 6 = **WCOL** *Write Collision status.*

This bit is set by hardware when a write to the DR register is done during a transmit sequence. It is cleared by a software sequence (see [Figure 45](#)).

0: No write collision occurred
 1: A write collision has been detected

Bit 5 = Unused.

Bit 4 = **MODF** *Mode Fault flag.*

This bit is set by hardware when the \overline{SS} pin is pulled low in master mode (see [Section 13.4.4.5 "Master Mode Fault" on page 80](#)). An SPI interrupt can be generated if SPIE=1 in the CR register. This bit is cleared by a software sequence (An access to the SR register while MODF=1 followed by a write to the CR register).

0: No master mode fault detected
 1: A fault in master mode has been detected

Bits 3:0 = Unused.

DATA I/O REGISTER (DR)

Read/Write

Reset Value: Undefined

7							0
D7	D6	D5	D4	D3	D2	D1	D0

The DR register is used to transmit and receive data on the serial bus. In the master device only a write to this register will initiate transmission/reception of another byte.

Notes: During the last clock cycle the SPIF bit is set, a copy of the received data byte in the shift register is moved to a buffer. When the user reads the serial peripheral data I/O register, the buffer is actually being read.

Warning:

A write to the DR register places data directly into the shift register for transmission.

A read to the DR register returns the value located in the buffer and not the contents of the shift register (See [Figure 42](#)).

SERIAL PERIPHERAL INTERFACE (Cont'd)

Table 18. SPI Register Map and Reset Values

Address (Hex.)	Register Label	7	6	5	4	3	2	1	0
0021h	SPIDR Reset Value	MSB x	x	x	x	x	x	x	LSB x
0022h	SPICR Reset Value	SPIE 0	SPE 0	SPR2 0	MSTR 0	CPOL x	CPHA x	SPR1 x	SPR0 x
0023h	SPISR Reset Value	SPIF 0	WCOL 0	0	MODF 0	0	0	0	0

13.5 SERIAL COMMUNICATIONS INTERFACE (SCI)

13.5.1 Introduction

The Serial Communications Interface (SCI) offers a flexible means of full-duplex data exchange with external equipment requiring an industry standard NRZ asynchronous

serial data format. The SCI offers a very wide range of baud rates using two baud rate generator systems.

13.5.2 Main Features

- Full duplex, asynchronous communications
- NRZ standard format (Mark/Space)
- Dual baud rate generator systems
- Independently programmable transmit and receive baud rates up to 250K baud using conventional baud rate generator and up to 500K baud using the extended baud rate generator.
- Programmable data word length (8 or 9 bits)
- Receive buffer full, Transmit buffer empty and End of Transmission flags
- Two receiver wake-up modes:
 - Address bit (MSB)
 - Idle line
- Muting function for multiprocessor configurations
- LIN compatible (if MCU clock frequency tolerance $\leq 2\%$)
- Separate enable bits for Transmitter and Receiver
- Three error detection flags:
 - Overrun error
 - Noise error
 - Frame error
- Five interrupt sources with flags:
 - Transmit data register empty
 - Transmission complete
 - Receive data register full
 - Idle line received
 - Overrun error detected

13.5.3 General Description

The interface is externally connected to another device by two pins (see [Figure 48](#)):

- TDO: Transmit Data Output. When the transmitter is disabled, the output pin returns to its I/O port configuration. When the transmitter is enabled and nothing is to be transmitted, the TDO pin is at high level.
- RDI: Receive Data Input is the serial data input. Oversampling techniques are used for data recovery by discriminating between valid incoming data and noise.

Through this pins, serial data is transmitted and received as frames comprising:

- An Idle Line prior to transmission or reception
- A start bit
- A data word (8 or 9 bits) least significant bit first
- A Stop bit indicating that the frame is complete.

This interface uses two types of baud rate generator:

- A conventional type for commonly-used baud rates,
- An extended type with a prescaler offering a very wide range of baud rates even with non-standard oscillator frequencies.

13.5.4 LIN Protocol support

For LIN applications where resynchronization is not required (application clock tolerance less than or equal to 2%) the LIN protocol can be efficiently implemented with this standard SCI.

SERIAL COMMUNICATIONS INTERFACE (Cont'd)

13.5.5 Functional Description

The block diagram of the Serial Control Interface, is shown in [Figure 47](#). It contains six dedicated registers:

- 2 control registers (CR1 and CR2)
- A status register (SR)
- A baud rate register (BRR)
- An extended prescaler receiver register (ERPR)
- An extended prescaler transmitter register (ETPR)

Refer to the register descriptions in [Section 13.5.8](#) for the definitions of each bit.

13.5.5.1 Serial Data Format

Word length may be selected as being either 8 or 9 bits by programming the M bit in the CR1 register (see [Figure 47](#)).

The TDO pin is in low state during the start bit.

The TDO pin is in high state during the stop bit.

An Idle character is interpreted as an entire frame of "1"s followed by the start bit of the next frame which contains data.

A Break character is interpreted on receiving '0's for some multiple of the frame period. At the end of the last break frame the transmitter inserts an extra '1' bit to acknowledge the start bit.

Transmission and reception are driven by their own baud rate generator.

Figure 48. Word length programming

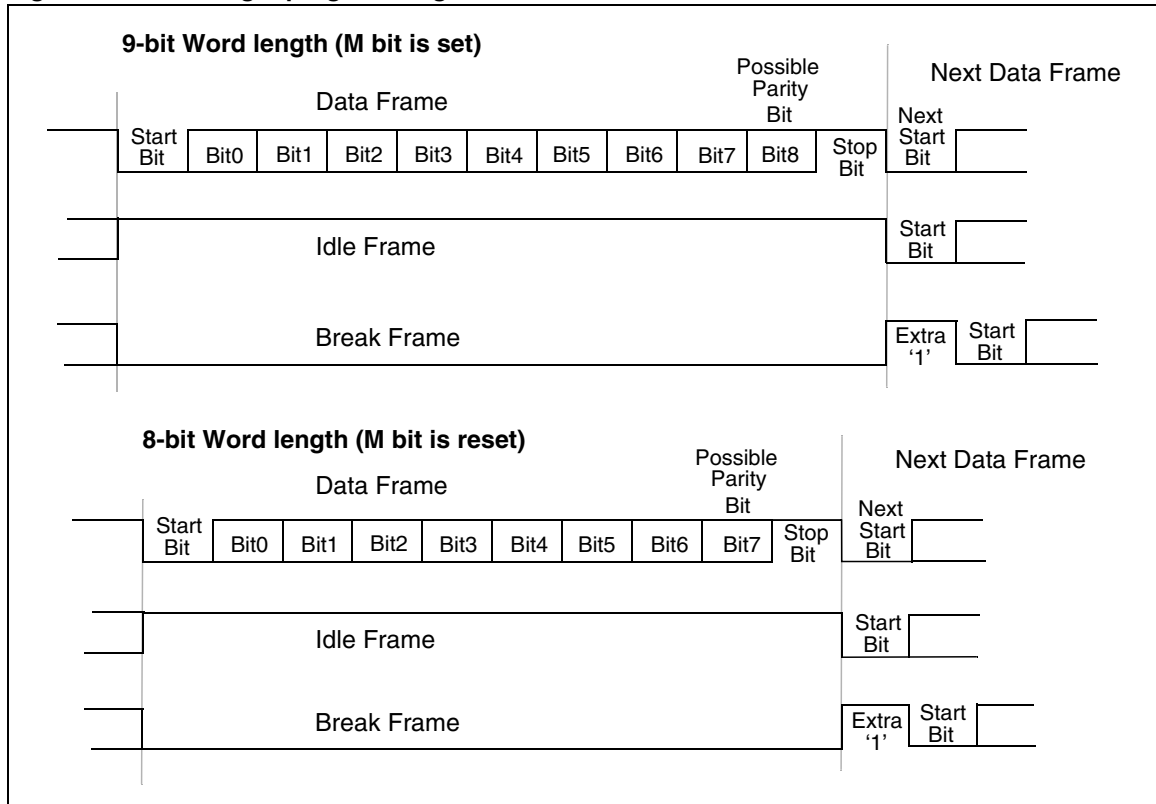

SERIAL COMMUNICATIONS INTERFACE (Cont'd)**13.5.5.2 Transmitter**

The transmitter can send data words of either 8 or 9 bits depending on the M bit status. When the M bit is set, word length is 9 bits and the 9th bit (the MSB) has to be stored in the T8 bit in the CR1 register.

Character Transmission

During an SCI transmission, data shifts out least significant bit first on the TDO pin. In this mode, the DR register consists of a buffer (TDR) between the internal bus and the transmit shift register (see [Figure 47](#)).

Procedure

- Select the M bit to define the word length.
- Select the desired baud rate using the BRR and the ETPR registers.
- Set the TE bit to assign the TDO pin to the alternate function and to send an idle frame as first transmission.
- Access the SR register and write the data to send in the DR register (this sequence clears the TDRE bit). Repeat this sequence for each data to be transmitted.

Clearing the TDRE bit is always performed by the following software sequence:

1. An access to the SR register
2. A write to the DR register

The TDRE bit is set by hardware and it indicates:

- The TDR register is empty.
- The data transfer is beginning.
- The next data can be written in the DR register without overwriting the previous data.

This flag generates an interrupt if the TIE bit is set and the I bit is cleared in the CCR register.

When a transmission is taking place, a write instruction to the DR register stores the data in the TDR register and which is copied in the shift register at the end of the current transmission.

When no transmission is taking place, a write instruction to the DR register places the data directly in the shift register, the data transmission starts, and the TDRE bit is immediately set.

When a frame transmission is complete (after the stop bit or after the break frame) the TC bit is set and an interrupt is generated if the TCIE is set and the I bit is cleared in the CCR register.

Clearing the TC bit is performed by the following software sequence:

1. An access to the SR register
2. A write to the DR register

Note: The TDRE and TC bits are cleared by the same software sequence.

Break Characters

Setting the SBK bit loads the shift register with a break character. The break frame length depends on the M bit (see [Figure 48](#)).

As long as the SBK bit is set, the SCI send break frames to the TDO pin. After clearing this bit by software the SCI insert a logic 1 bit at the end of the last break frame to guarantee the recognition of the start bit of the next frame.

Idle Characters

Setting the TE bit drives the SCI to send an idle frame before the first data frame.

Clearing and then setting the TE bit during a transmission sends an idle frame after the current word.

Note: Resetting and setting the TE bit causes the data in the TDR register to be lost. Therefore the best time to toggle the TE bit is when the TDRE bit is set i.e. before writing the next byte in the DR.

SERIAL COMMUNICATIONS INTERFACE (Cont'd)

13.5.5.3 Receiver

The SCI can receive data words of either 8 or 9 bits. When the M bit is set, word length is 9 bits and the MSB is stored in the R8 bit in the CR1 register.

Character reception

During a SCI reception, data shifts in least significant bit first through the RDI pin. In this mode, DR register consists in a buffer (RDR) between the internal bus and the received shift register (see [Figure 47](#)).

Procedure

- Select the M bit to define the word length.
- Select the desired baud rate using the BRR and the ERPR registers.
- Set the RE bit, this enables the receiver which begins searching for a start bit.

When a character is received:

- The RDRF bit is set. It indicates that the content of the shift register is transferred to the RDR.
- An interrupt is generated if the RIE bit is set and the I bit is cleared in the CCR register.
- The error flags can be set if a frame error, noise or an overrun error has been detected during reception.

Clearing the RDRF bit is performed by the following software sequence done by:

1. An access to the SR register
2. A read to the DR register.

The RDRF bit must be cleared before the end of the reception of the next character to avoid an overrun error.

Break Character

When a break character is received, the SCI handles it as a framing error.

Idle Character

When an idle frame is detected, there is the same procedure as a data received character plus an interrupt if the ILIE bit is set and the I bit is cleared in the CCR register.

Overrun Error

An overrun error occurs when a character is received when RDRF has not been reset. Data can not be transferred from the shift register to the TDR register as long as the RDRF bit is not cleared.

When an overrun error occurs:

- The OR bit is set.
- The RDR content will not be lost.
- The shift register will be overwritten.
- An interrupt is generated if the RIE bit is set and the I bit is cleared in the CCR register.

The OR bit is reset by an access to the SR register followed by a DR register read operation.

Noise Error

Oversampling techniques are used for data recovery by discriminating between valid incoming data and noise.

When noise is detected in a frame:

- The NF is set at the rising edge of the RDRF bit.
- Data is transferred from the Shift register to the DR register.
- No interrupt is generated. However this bit rises at the same time as the RDRF bit which itself generates an interrupt.

The NF bit is reset by a SR register read operation followed by a DR register read operation.

Framing Error

A framing error is detected when:

- The stop bit is not recognized on reception at the expected time, following either a desynchronization or excessive noise.
- A break is received.

When the framing error is detected:

- the FE bit is set by hardware
- Data is transferred from the Shift register to the DR register.
- No interrupt is generated. However this bit rises at the same time as the RDRF bit which itself generates an interrupt.

The FE bit is reset by a SR register read operation followed by a DR register read operation.

SERIAL COMMUNICATIONS INTERFACE (Cont'd)

Figure 49. SCI Baud Rate and Extended Prescaler Block Diagram

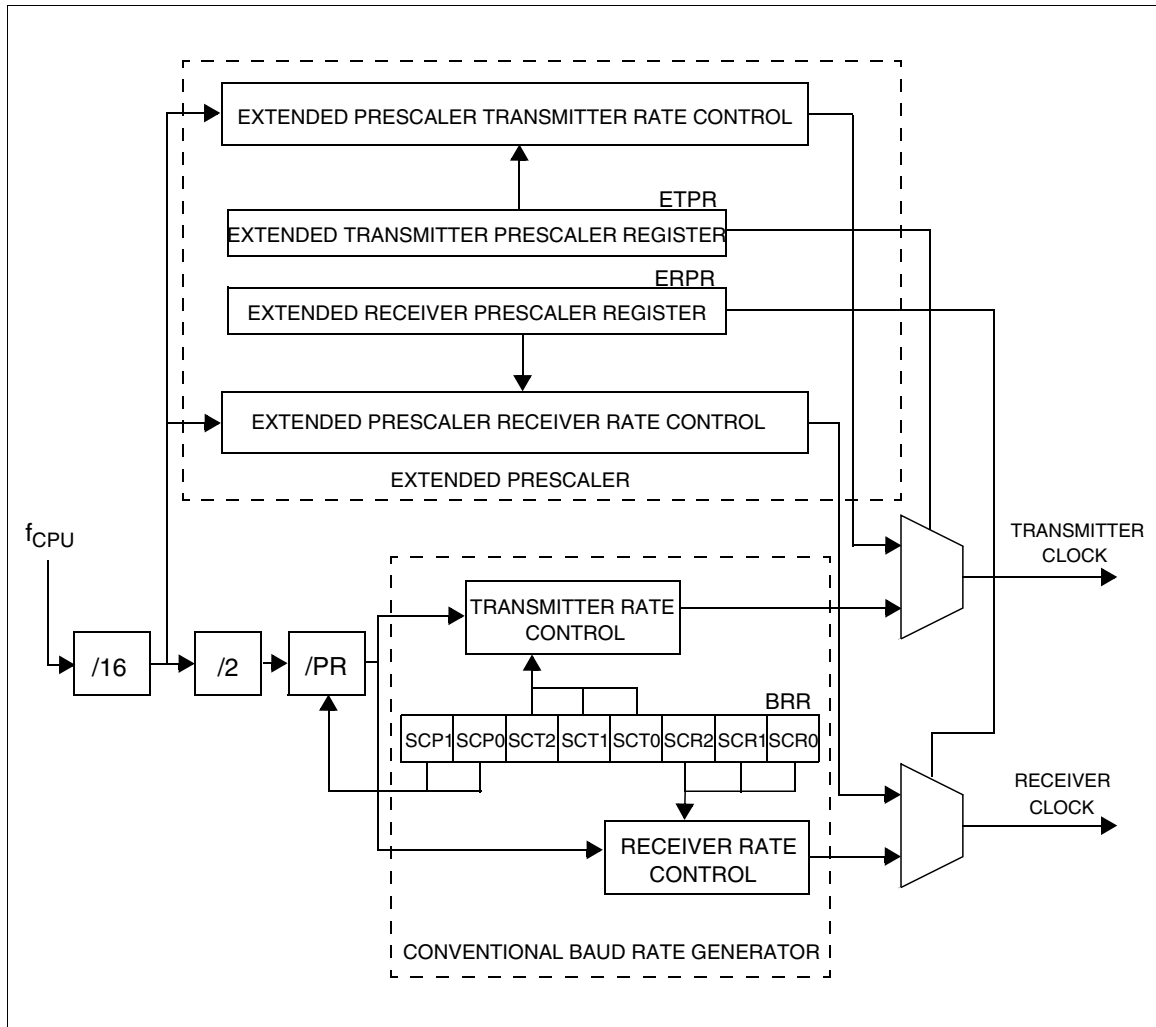

SERIAL COMMUNICATIONS INTERFACE (Cont'd)

13.5.5.4 Conventional Baud Rate Generation

The baud rate for the receiver and transmitter (Rx and Tx) are set independently and calculated as follows:

$$Tx = \frac{f_{CPU}}{(32 \cdot PR) \cdot TR} \quad Rx = \frac{f_{CPU}}{(32 \cdot PR) \cdot RR}$$

with:

PR = 1, 3, 4 or 13 (see SCP0 and SCP1 bits)

TR = 1, 2, 4, 8, 16, 32, 64, 128

(see SCT0, SCT1 and SCT2 bits)

RR = 1, 2, 4, 8, 16, 32, 64, 128

(see SCR0, SCR1 and SCR2 bits)

All this bits are in the BRR register.

Example: If f_{CPU} is 8 MHz (normal mode) and if PR = 13 and TR = RR = 1, the transmit and receive baud rates are 19200 baud.

Caution: The baud rate register (SCIBRR) MUST NOT be written to (changed or refreshed) while the transmitter or the receiver is enabled.

13.5.5.5 Extended Baud Rate Generation

The extended prescaler option gives a very fine tuning on the baud rate, using a 255 value prescaler, whereas the conventional Baud Rate Generator retains industry standard software compatibility.

The extended baud rate generator block diagram is described in the [Figure 49](#).

The output clock rate sent to the transmitter or to the receiver will be the output from the 16 divider divided by a factor ranging from 1 to 255 set in the ERPR or the ETPR register.

Note: the extended prescaler is activated by setting the ETPR or ERPR register to a value other

than zero. The baud rates are calculated as follows:

$$Tx = \frac{f_{CPU}}{16 \cdot ETPR} \quad Rx = \frac{f_{CPU}}{16 \cdot ERPR}$$

with:

ETPR = 1,...,255 (see ETPR register)

ERPR = 1,... 255 (see ERPR register)

13.5.5.6 Receiver Muting and Wake-up Feature

In multiprocessor configurations it is often desirable that only the intended message recipient should actively receive the full message contents, thus reducing redundant SCI service overhead for all non addressed receivers.

The non addressed devices may be placed in sleep mode by means of the muting function.

Setting the RWU bit by software puts the SCI in sleep mode:

All the reception status bits can not be set.

All the receive interrupt are inhibited.

A muted receiver may be awakened by one of the following two ways:

- by Idle Line detection if the WAKE bit is reset,
- by Address Mark detection if the WAKE bit is set.

Receiver wakes-up by Idle Line detection when the Receive line has recognized an Idle Frame. Then the RWU bit is reset by hardware but the IDLE bit is not set.

Receiver wakes-up by Address Mark detection when it received a "1" as the most significant bit of a word, thus indicating that the message is an address. The reception of this particular word wakes up the receiver, resets the RWU bit and sets the RDRF bit, which allows the receiver to receive this word normally and to use it as an address word.

SERIAL COMMUNICATIONS INTERFACE (Cont'd)

13.5.6 Low Power Modes

Mode	Description
WAIT	No effect on SCI. SCI interrupts cause the device to exit from Wait mode.
HALT	SCI registers are frozen. In Halt mode, the SCI stops transmitting/receiving until Halt mode is exited.

13.5.7 Interrupts

Interrupt Event	Event Flag	Enable Control Bit	Exit from Wait	Exit from Halt
Transmit Data Register Empty	TDRE	TIE	Yes	No
Transmission Complete	TC	TCIE	Yes	No
Received Data Ready to be Read	RDRF	RIE	Yes	No
Overrun Error Detected	OR		Yes	No
Idle Line Detected	IDLE	ILIE	Yes	No

The SCI interrupt events are connected to the same interrupt vector (see [INTERRUPTS](#) chapter).

These events generate an interrupt if the corresponding Enable Control Bit is set and the interrupt mask in the CC register is reset (RIM instruction).

SERIAL COMMUNICATIONS INTERFACE (Cont'd)

13.5.8 Register Description

STATUS REGISTER (SR)

Read Only

Reset Value: 1100 0000 (C0h)

7							0
TDRE	TC	RDRF	IDLE	OR	NF	FE	-

Bit 7 = TDRE *Transmit data register empty.*
 This bit is set by hardware when the content of the TDR register has been transferred into the shift register. An interrupt is generated if the TIE =1 in the CR2 register. It is cleared by a software sequence (an access to the SR register followed by a write to the DR register).

0: Data is not transferred to the shift register
 1: Data is transferred to the shift register

Note: data will not be transferred to the shift register as long as the TDRE bit is not reset.

Bit 6 = TC *Transmission complete.*

This bit is set by hardware when transmission of a frame containing Data, a Preamble or a Break is complete. An interrupt is generated if TCIE=1 in the CR2 register. It is cleared by a software sequence (an access to the SR register followed by a write to the DR register).

0: Transmission is not complete
 1: Transmission is complete

Bit 5 = RDRF *Received data ready flag.*

This bit is set by hardware when the content of the RDR register has been transferred into the DR register. An interrupt is generated if RIE=1 in the CR2 register. It is cleared by a software sequence (an access to the SR register followed by a read to the DR register).

0: Data is not received
 1: Received data is ready to be read

Bit 4 = IDLE *Idle line detect.*

This bit is set by hardware when an Idle Line is detected. An interrupt is generated if the ILIE=1 in the CR2 register. It is cleared by a software sequence (an access to the SR register followed by a read to the DR register).

0: No Idle Line is detected
 1: Idle Line is detected

Note: The IDLE bit will not be set again until the RDRF bit has been set itself (i.e. a new idle line occurs). This bit is not set by an idle line when the receiver wakes up from wake-up mode.

Bit 3 = OR *Overrun error.*

This bit is set by hardware when the word currently being received in the shift register is ready to be transferred into the RDR register while RDRF=1. An interrupt is generated if RIE=1 in the CR2 register. It is cleared by a software sequence (an access to the SR register followed by a read to the DR register).

0: No Overrun error
 1: Overrun error is detected

Note: When this bit is set RDR register content will not be lost but the shift register will be overwritten.

Bit 2 = NF *Noise flag.*

This bit is set by hardware when noise is detected on a received frame. It is cleared by a software sequence (an access to the SR register followed by a read to the DR register).

0: No noise is detected
 1: Noise is detected

Note: This bit does not generate interrupt as it appears at the same time as the RDRF bit which itself generates an interrupt.

Bit 1 = FE *Framing error.*

This bit is set by hardware when a desynchronization, excessive noise or a break character is detected. It is cleared by a software sequence (an access to the SR register followed by a read to the DR register).

0: No Framing error is detected
 1: Framing error or break character is detected

Note: This bit does not generate interrupt as it appears at the same time as the RDRF bit which itself generates an interrupt. If the word currently being transferred causes both frame error and overrun error, it will be transferred and only the OR bit will be set.

Bit 0 = Unused.

SERIAL COMMUNICATIONS INTERFACE (Cont'd)

CONTROL REGISTER 1 (CR1)

Read/Write

Reset Value: Undefined

7							0
R8	T8	-	M	WAKE	-	-	-

Bit 7 = R8 Receive data bit 8.
This bit is used to store the 9th bit of the received word when M=1.

Bit 6 = T8 Transmit data bit 8.
This bit is used to store the 9th bit of the transmitted word when M=1.

Bit 4 = M Word length.
This bit determines the word length. It is set or cleared by software.
0: 1 Start bit, 8 Data bits, 1 Stop bit
1: 1 Start bit, 9 Data bits, 1 Stop bit

Bit 3 = WAKE Wake-Up method.
This bit determines the SCI Wake-Up method, it is set or cleared by software.
0: Idle Line
1: Address Mark

CONTROL REGISTER 2 (CR2)

Read/Write

Reset Value: 0000 0000 (00h)

7							0
TIE	TCIE	RIE	ILIE	TE	RE	RWU	SBK

Bit 7 = TIE Transmitter interrupt enable.
This bit is set and cleared by software.
0: interrupt is inhibited
1: An SCI interrupt is generated whenever TDRE=1 in the SR register.

Bit 6 = TCIE Transmission complete interrupt enable
This bit is set and cleared by software.
0: interrupt is inhibited

1: An SCI interrupt is generated whenever TC=1 in the SR register

Bit 5 = RIE Receiver interrupt enable.
This bit is set and cleared by software.
0: interrupt is inhibited

1: An SCI interrupt is generated whenever OR=1 or RDRF=1 in the SR register

Bit 4 = ILIE Idle line interrupt enable.
This bit is set and cleared by software.
0: interrupt is inhibited
1: An SCI interrupt is generated whenever IDLE=1 in the SR register.

Bit 3 = TE Transmitter enable.
This bit enables the transmitter and assigns the TDO pin to the alternate function. It is set and cleared by software.
0: Transmitter is disabled, the TDO pin is back to the I/O port configuration.
1: Transmitter is enabled

Note: during transmission, a “0” pulse on the TE bit (“0” followed by “1”) sends a preamble after the current word.

Bit 2 = RE Receiver enable.
This bit enables the receiver. It is set and cleared by software.
0: Receiver is disabled.
1: Receiver is enabled and begins searching for a start bit.

Bit 1 = RWU Receiver wake-up.
This bit determines if the SCI is in mute mode or not. It is set and cleared by software and can be cleared by hardware when a wake-up sequence is recognized.
0: Receiver in active mode
1: Receiver in mute mode

Bit 0 = SBK Send break.
This bit set is used to send break characters. It is set and cleared by software.
0: No break character is transmitted
1: Break characters are transmitted

Note: If the SBK bit is set to “1” and then to “0”, the transmitter will send a BREAK word at the end of the current word.

SERIAL COMMUNICATIONS INTERFACE (Cont'd)

DATA REGISTER (DR)

Read/Write

Reset Value: Undefined

Contains the Received or Transmitted data character, depending on whether it is read from or written to.

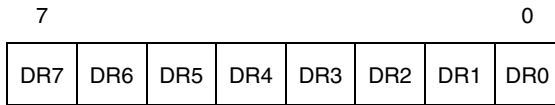

The Data register performs a double function (read and write) since it is composed of two registers, one for transmission (TDR) and one for reception (RDR).

The TDR register provides the parallel interface between the internal bus and the output shift register (see [Figure 47](#)).

The RDR register provides the parallel interface between the input shift register and the internal bus (see [Figure 47](#)).

BAUD RATE REGISTER (BRR)

Read/Write

Reset Value: 00xx xxxx (XXh)

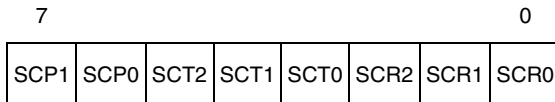

Bit 7:6= **SCP[1:0]** *First SCI Prescaler*

These 2 prescaling bits allow several standard clock division ranges:

PR Prescaling factor	SCP1	SCP0
1	0	0
3	0	1
4	1	0
13	1	1

Bit 5:3 = **SCT[2:0]** *SCI Transmitter rate divisor*

These 3 bits, in conjunction with the SCP1 and SCP0 bits, define the total division applied to the bus clock to yield the transmit rate clock in conventional Baud Rate Generator mode.

TR dividing factor	SCT2	SCT1	SCT0
1	0	0	0
2	0	0	1
4	0	1	0
8	0	1	1
16	1	0	0
32	1	0	1
64	1	1	0
128	1	1	1

Note: this TR factor is used only when the ETPR fine tuning factor is equal to 00h; otherwise, TR is replaced by the ETPR dividing factor.

Bit 2:0 = **SCR[2:0]** *SCI Receiver rate divisor.*

These 3 bits, in conjunction with the SCP1 and SCP0 bits define the total division applied to the bus clock to yield the receive rate clock in conventional Baud Rate Generator mode.

RR dividing factor	SCR2	SCR1	SCR0
1	0	0	0
2	0	0	1
4	0	1	0
8	0	1	1
16	1	0	0
32	1	0	1
64	1	1	0
128	1	1	1

Note: this RR factor is used only when the ERPR fine tuning factor is equal to 00h; otherwise, RR is replaced by the ERPR dividing factor.

SERIAL COMMUNICATIONS INTERFACE (Cont'd)

EXTENDED RECEIVE PRESCALER DIVISION REGISTER (ERPR)

Read/Write

Reset Value: 0000 0000 (00h)

Allows setting of the Extended Prescaler rate division factor for the receive circuit.

7							0
ERPR 7	ERPR 6	ERPR 5	ERPR 4	ERPR 3	ERPR 2	ERPR 1	ERPR 0

Bit 7:1 = **ERPR[7:0]** 8-bit Extended Receive Prescaler Register.

The extended Baud Rate Generator is activated when a value different from 00h is stored in this register. Therefore the clock frequency issued from the 16 divider (see Figure 49) is divided by the binary factor set in the ERPR register (in the range 1 to 255).

The extended baud rate generator is not used after a reset.

EXTENDED TRANSMIT PRESCALER DIVISION REGISTER (ETPR)

Read/Write

Reset Value: 0000 0000 (00h)

Allows setting of the External Prescaler rate division factor for the transmit circuit.

7							0
ETPR 7	ETPR 6	ETPR 5	ETPR 4	ETPR 3	ETPR 2	ETPR 1	ETPR 0

Bit 7:1 = **ETPR[7:0]** 8-bit Extended Transmit Prescaler Register.

The extended Baud Rate Generator is activated when a value different from 00h is stored in this register. Therefore the clock frequency issued from the 16 divider (see Figure 49) is divided by the binary factor set in the ETPR register (in the range 1 to 255).

The extended baud rate generator is not used after a reset.

Table 19. SCI Register Map and Reset Values

Address (Hex.)	Register Label	7	6	5	4	3	2	1	0
0050h	SCISR Reset Value	TDRE 1	TC 1	RDRF 0	IDLE 0	OR 0	NF 0	FE 0	0
0051h	SCIDR Reset Value	MSB x	x	x	x	x	x	x	LSB x
0052h	SCIBRR Reset Value	SOG 0	0	VPOL x	2FHDET x	HVSEL x	VCORDIS x	CLPINV x	BLKINV x
0053h	SCICR1 Reset Value	R8 x	T8 x	0	M x	WAKE x	0	0	0
0054h	SCICR2 Reset Value	TIE 0	TCIE 0	RIE 0	ILIE 0	TE 0	RE 0	RWU 0	SBK 0
0055h	SCIPBRR Reset Value	MSB 0	0	0	0	0	0	0	LSB 0
0057h	SCIPBRT Reset Value	MSB 0	0	0	0	0	0	0	LSB 0

13.6 8-BIT A/D CONVERTER (ADC)

13.6.1 Introduction

The on-chip Analog to Digital Converter (ADC) peripheral is a 8-bit, successive approximation converter with internal sample and hold circuitry. This peripheral has up to 16 multiplexed analog input channels (refer to device pin out description) that allow the peripheral to convert the analog voltage levels from up to 16 different sources.

The result of the conversion is stored in a 8-bit Data Register. The A/D converter is controlled through a Control/Status Register.

13.6.2 Main Features

- 8-bit conversion
- Up to 16 channels with multiplexed input
- Linear successive approximation
- Data register (DR) which contains the results
- Conversion complete status flag
- On/off bit (to reduce consumption)

The block diagram is shown in [Figure 50](#).

13.6.3 Functional Description

13.6.3.1 Analog Power Supply

V_{DDA} and V_{SSA} are the high and low level reference voltage pins. In some devices (refer to device pin out description) they are internally connected to the V_{DD} and V_{SS} pins.

Conversion accuracy may therefore be impacted by voltage drops and noise in the event of heavily loaded or badly decoupled power supply lines.

See [ELECTRICAL CHARACTERISTICS](#) section for more details.

Figure 50. ADC Block Diagram

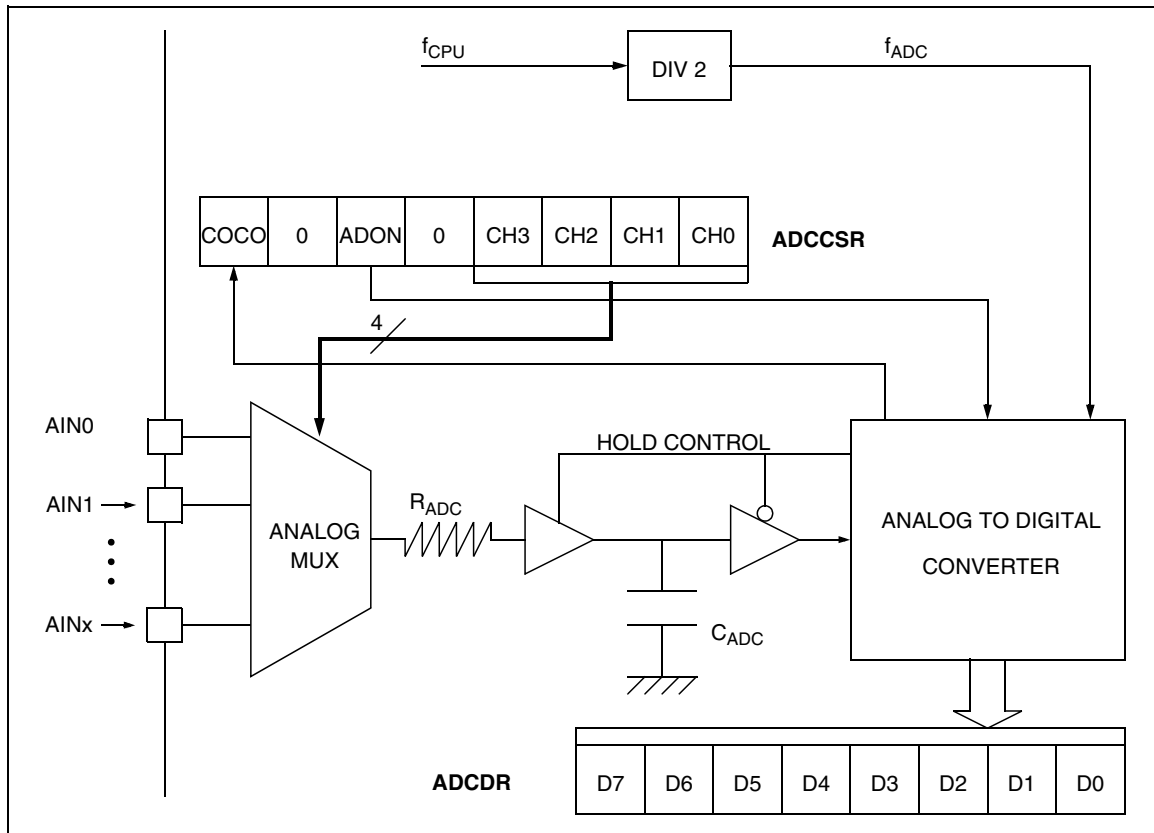

8-BIT A/D CONVERTER (ADC) (Cont'd)

13.6.3.2 Digital A/D Conversion Result

The conversion is monotonic, meaning that the result never decreases if the analog input does not and never increases if the analog input does not.

If the input voltage (V_{AIN}) is greater than or equal to V_{DDA} (high-level voltage reference) then the conversion result in the DR register is FFh (full scale) without overflow indication.

If input voltage (V_{AIN}) is lower than or equal to V_{SSA} (low-level voltage reference) then the conversion result in the DR register is 00h.

The A/D converter is linear and the digital result of the conversion is stored in the ADCDR register. The accuracy of the conversion is described in the parametric section.

R_{AIN} is the maximum recommended impedance for an analog input signal. If the impedance is too high, this will result in a loss of accuracy due to leakage and sampling not being completed in the allotted time.

13.6.3.3 A/D Conversion Phases

The A/D conversion is based on two conversion phases as shown in Figure 51:

- Sample capacitor loading [duration: t_{LOAD}]
During this phase, the V_{AIN} input voltage to be measured is loaded into the C_{ADC} sample capacitor.
- A/D conversion [duration: t_{CONV}]
During this phase, the A/D conversion is computed (8 successive approximations cycles) and the C_{ADC} sample capacitor is disconnected from the analog input pin to get the optimum analog to digital conversion accuracy.

While the ADC is on, these two phases are continuously repeated.

At the end of each conversion, the sample capacitor is kept loaded with the previous measurement load. The advantage of this behavior is that it minimizes the current consumption on the analog pin in case of single input channel measurement.

13.6.3.4 Software Procedure

Refer to the control/status register (CSR) and data register (DR) in Section 13.6.6 for the bit definitions and to Figure 51 for the timings.

ADC Configuration

The total duration of the A/D conversion is 12 ADC clock periods ($1/f_{ADC} = 2/f_{CPU}$).

The analog input ports must be configured as input, no pull-up, no interrupt. Refer to the I/O PORTS chapter. Using these pins as analog inputs does not affect the ability of the port to be read as a logic input.

In the CSR register:

- Select the CH[3:0] bits to assign the analog channel to be converted.

ADC Conversion

In the CSR register:

- Set the ADON bit to enable the A/D converter and to start the first conversion. From this time on, the ADC performs a continuous conversion of the selected channel.

When a conversion is complete

- The COCO bit is set by hardware.
- No interrupt is generated.
- The result is in the DR register and remains valid until the next conversion has ended.

A write to the CSR register (with ADON set) aborts the current conversion, resets the COCO bit and starts a new conversion.

Figure 51. ADC Conversion Timings

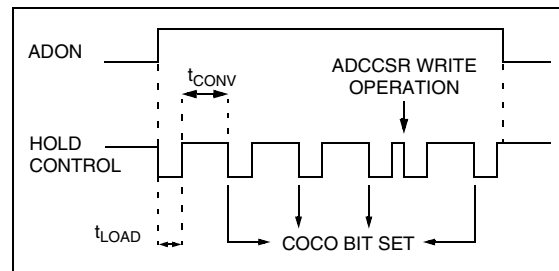

13.6.4 Low Power Modes

Mode	Description
WAIT	No effect on A/D Converter
HALT	A/D Converter disabled. After wake-up from Halt mode, the A/D Converter requires a stabilization time before accurate conversions can be performed.

Note: The A/D converter may be disabled by resetting the ADON bit. This feature allows reduced power consumption when no conversion is needed and between single shot conversions.

13.6.5 Interrupts

None

8-BIT A/D CONVERTER (ADC) (Cont'd)

13.6.6 Register Description

CONTROL/STATUS REGISTER (CSR)

Read/Write

Reset Value: 0000 0000 (00h)

7							0
COCO	0	ADON	0	CH3	CH2	CH1	CH0

Bit 7 = **COCO** *Conversion Complete*
 This bit is set by hardware. It is cleared by software reading the result in the DR register or writing to the CSR register.
 0: Conversion is not complete
 1: Conversion can be read from the DR register

Bit 6 = **Reserved**. *Must always be cleared.*

Bit 5 = **ADON** *A/D Converter On*
 This bit is set and cleared by software.
 0: A/D converter is switched off
 1: A/D converter is switched on

Bit 4 = **Reserved**. *Must always be cleared.*

Bits 3:0 = **CH[3:0]** *Channel Selection*
 These bits are set and cleared by software. They select the analog input to convert.

Channel Pin ¹⁾	CH3	CH2	CH1	CH0
AIN0	0	0	0	0
AIN1	0	0	0	1
AIN2	0	0	1	0
AIN3	0	0	1	1
AIN4	0	1	0	0
AIN5	0	1	0	1
AIN6	0	1	1	0
AIN7	0	1	1	1
AIN8	1	0	0	0
AIN9	1	0	0	1
AIN10	1	0	1	0
AIN11	1	0	1	1
AIN12	1	1	0	0
AIN13	1	1	0	1
AIN14	1	1	1	0
AIN15	1	1	1	1

Notes:
 1. The number of pins AND the channel selection varies according to the device. Refer to the device pinout.

DATA REGISTER (DR)

Read Only

Reset Value: 0000 0000 (00h)

7							0
D7	D6	D5	D4	D3	D2	D1	D0

Bits 7:0 = **D[7:0]** *Analog Converted Value*
 This register contains the converted analog value in the range 00h to FFh.

Note: Reading this register reset the COCO flag.

8-BIT A/D CONVERTER (ADC) (Cont'd)

Table 20. ADC Register Map and Reset Values

Address (Hex.)	Register Label	7	6	5	4	3	2	1	0
0070h	ADCDR Reset Value	D7 0	D6 0	D5 0	D4 0	D3 0	D2 0	D1 0	D0 0
0071h	ADCCSR Reset Value	COCO 0	0	ADON 0	0	CH3 0	CH2 0	CH1 0	CH0 0

14 INSTRUCTION SET

14.1 ST7 ADDRESSING MODES

The ST7 Core features 17 different addressing modes which can be classified in 7 main groups:

Addressing Mode Group	Example
Inherent	nop
Immediate	ld A,#\$55
Direct	ld A,\$55
Indexed	ld A,(\$55,X)
Indirect	ld A,([\$55],X)
Relative	jrne loop
Bit operation	bset byte,#5

The ST7 Instruction set is designed to minimize the number of bytes required per instruction: To do

so, most of the addressing modes may be subdivided in two sub-modes called long and short:

- Long addressing mode is more powerful because it can use the full 64 Kbyte address space, however it uses more bytes and more CPU cycles.
- Short addressing mode is less powerful because it can generally only access page zero (0000h - 00FFh range), but the instruction size is more compact, and faster. All memory to memory instructions use short addressing modes only (CLR, CPL, NEG, BSET, BRES, BTJT, BTJF, INC, DEC, RLC, RRC, SLL, SRL, SRA, SWAP)

The ST7 Assembler optimizes the use of long and short addressing modes.

Table 21. ST7 Addressing Mode Overview

Mode			Syntax	Destination/ Source	Pointer Address (Hex.)	Pointer Size (Hex.)	Length (bytes)
Inherent			nop				+ 0
Immediate			ld A,#\$55				+ 1
Short	Direct		ld A,\$10	00..FF			+ 1
Long	Direct		ld A,\$1000	0000..FFFF			+ 2
No Offset	Direct	Indexed	ld A,(X)	00..FF			+ 0 (with X register) + 1 (with Y register)
Short	Direct	Indexed	ld A,(\$10,X)	00..1FE			+ 1
Long	Direct	Indexed	ld A,(\$1000,X)	0000..FFFF			+ 2
Short	Indirect		ld A,[\$10]	00..FF	00..FF	byte	+ 2
Long	Indirect		ld A,[\$10.w]	0000..FFFF	00..FF	word	+ 2
Short	Indirect	Indexed	ld A,([\$10],X)	00..1FE	00..FF	byte	+ 2
Long	Indirect	Indexed	ld A,([\$10.w],X)	0000..FFFF	00..FF	word	+ 2
Relative	Direct		jrne loop	PC-128/PC+127 ¹⁾			+ 1
Relative	Indirect		jrne [\$10]	PC-128/PC+127 ¹⁾	00..FF	byte	+ 2
Bit	Direct		bset \$10,#7	00..FF			+ 1
Bit	Indirect		bset [\$10],#7	00..FF	00..FF	byte	+ 2
Bit	Direct	Relative	btjt \$10,#7,skip	00..FF			+ 2
Bit	Indirect	Relative	btjt [\$10],#7,skip	00..FF	00..FF	byte	+ 3

Notes:

1. At the time the instruction is executed, the Program Counter (PC) points to the instruction following JRxx.

ST7 ADDRESSING MODES (Cont'd)

14.1.1 Inherent

All Inherent instructions consist of a single byte. The opcode fully specifies all the required information for the CPU to process the operation.

Inherent Instruction	Function
NOP	No operation
TRAP	S/W Interrupt
WFI	Wait For Interrupt (Low Power Mode)
HALT	Halt Oscillator (Lowest Power Mode)
RET	Sub-routine Return
IRET	Interrupt Sub-routine Return
SIM	Set Interrupt Mask
RIM	Reset Interrupt Mask
SCF	Set Carry Flag
RCF	Reset Carry Flag
RSP	Reset Stack Pointer
LD	Load
CLR	Clear
PUSH/POP	Push/Pop to/from the stack
INC/DEC	Increment/Decrement
TNZ	Test Negative or Zero
CPL, NEG	1 or 2 Complement
MUL	Byte Multiplication
SLL, SRL, SRA, RLC, RRC	Shift and Rotate Operations
SWAP	Swap Nibbles

14.1.2 Immediate

Immediate instructions have two bytes, the first byte contains the opcode, the second byte contains the operand value.

Immediate Instruction	Function
LD	Load
CP	Compare
BCP	Bit Compare
AND, OR, XOR	Logical Operations
ADC, ADD, SUB, SBC	Arithmetic Operations

14.1.3 Direct

In Direct instructions, the operands are referenced by their memory address.

The direct addressing mode consists of two sub-modes:

Direct (short)

The address is a byte, thus requires only one byte after the opcode, but only allows 00 - FF addressing space.

Direct (long)

The address is a word, thus allowing 64 Kbyte addressing space, but requires 2 bytes after the opcode.

14.1.4 Indexed (No Offset, Short, Long)

In this mode, the operand is referenced by its memory address, which is defined by the unsigned addition of an index register (X or Y) with an offset.

The indexed addressing mode consists of three sub-modes:

Indexed (No Offset)

There is no offset, (no extra byte after the opcode), and allows 00 - FF addressing space.

Indexed (Short)

The offset is a byte, thus requires only one byte after the opcode and allows 00 - 1FE addressing space.

Indexed (long)

The offset is a word, thus allowing 64 Kbyte addressing space and requires 2 bytes after the opcode.

14.1.5 Indirect (Short, Long)

The required data byte to do the operation is found by its memory address, located in memory (pointer).

The pointer address follows the opcode. The indirect addressing mode consists of two sub-modes:

Indirect (short)

The pointer address is a byte, the pointer size is a byte, thus allowing 00 - FF addressing space, and requires 1 byte after the opcode.

Indirect (long)

The pointer address is a byte, the pointer size is a word, thus allowing 64 Kbyte addressing space, and requires 1 byte after the opcode.

ST7 ADDRESSING MODES (Cont'd)

14.1.6 Indirect Indexed (Short, Long)

This is a combination of indirect and short indexed addressing modes. The operand is referenced by its memory address, which is defined by the unsigned addition of an index register value (X or Y) with a pointer value located in memory. The pointer address follows the opcode.

The indirect indexed addressing mode consists of two sub-modes:

Indirect Indexed (Short)

The pointer address is a byte, the pointer size is a byte, thus allowing 00 - 1FE addressing space, and requires 1 byte after the opcode.

Indirect Indexed (Long)

The pointer address is a byte, the pointer size is a word, thus allowing 64 Kbyte addressing space, and requires 1 byte after the opcode.

Table 22. Instructions Supporting Direct, Indexed, Indirect and Indirect Indexed Addressing Modes

Long and Short Instructions	Function
LD	Load
CP	Compare
AND, OR, XOR	Logical Operations
ADC, ADD, SUB, SBC	Arithmetic Addition/subtraction operations
BCP	Bit Compare

Short Instructions Only	Function
CLR	Clear
INC, DEC	Increment/Decrement
TNZ	Test Negative or Zero
CPL, NEG	1 or 2 Complement
BSET, BRES	Bit Operations
BTJT, BTJF	Bit Test and Jump Operations
SLL, SRL, SRA, RLC, RRC	Shift and Rotate Operations
SWAP	Swap Nibbles
CALL, JP	Call or Jump subroutine

14.1.7 Relative Mode (Direct, Indirect)

This addressing mode is used to modify the PC register value by adding an 8-bit signed offset to it.

Available Relative Direct/Indirect Instructions	Function
JRxx	Conditional Jump
CALLR	Call Relative

The relative addressing mode consists of two sub-modes:

Relative (Direct)

The offset follows the opcode.

Relative (Indirect)

The offset is defined in memory, of which the address follows the opcode.

14.2 INSTRUCTION GROUPS

The ST7 family devices use an Instruction Set consisting of 63 instructions. The instructions may be subdivided into 13 main groups as illustrated in the following table:

Group	Instructions							
Load and Transfer	LD	CLR						
Stack operation	PUSH	POP	RSP					
Increment/Decrement	INC	DEC						
Compare and Tests	CP	TNZ	BCP					
Logical operations	AND	OR	XOR	CPL	NEG			
Bit Operation	BSET	BRES						
Conditional Bit Test and Branch	BTJT	BTJF						
Arithmetic operations	ADC	ADD	SUB	SBC	MUL			
Shift and Rotates	SLL	SRL	SRA	RLC	RRC	SWAP	SLA	
Unconditional Jump or Call	JRA	JRT	JRF	JP	CALL	CALLR	NOP	RET
Conditional Branch	JRxx							
Interrupt management	TRAP	WFI	HALT	IRET				
Condition Code Flag modification	SIM	RIM	SCF	RCF				

Using a prebyte

The instructions are described with one to four bytes.

In order to extend the number of available opcodes for an 8-bit CPU (256 opcodes), three different prebyte opcodes are defined. These prebytes modify the meaning of the instruction they precede.

The whole instruction becomes:

- PC-2 End of previous instruction
- PC-1 Prebyte
- PC Opcode
- PC+1 Additional word (0 to 2) according to the number of bytes required to compute the effective address

These prebytes enable instruction in Y as well as indirect addressing modes to be implemented. They precede the opcode of the instruction in X or the instruction using direct addressing mode. The prebytes are:

- PDY 90 Replace an X based instruction using immediate, direct, indexed, or inherent addressing mode by a Y one.
- PIX 92 Replace an instruction using direct, direct bit, or direct relative addressing mode to an instruction using the corresponding indirect addressing mode. It also changes an instruction using X indexed addressing mode to an instruction using indirect X indexed addressing mode.
- PIY 91 Replace an instruction using X indirect indexed addressing mode by a Y one.

INSTRUCTION GROUPS (Cont'd)

Mnemo	Description	Function/Example	Dst	Src	H	I	N	Z	C
ADC	Add with Carry	$A = A + M + C$	A	M	H		N	Z	C
ADD	Addition	$A = A + M$	A	M	H		N	Z	C
AND	Logical And	$A = A . M$	A	M			N	Z	
BCP	Bit compare A, Memory	tst (A . M)	A	M			N	Z	
BRES	Bit Reset	bres Byte, #3	M						
BSET	Bit Set	bset Byte, #3	M						
BTJF	Jump if bit is false (0)	btjf Byte, #3, Jmp1	M						C
BTJT	Jump if bit is true (1)	btjt Byte, #3, Jmp1	M						C
CALL	Call subroutine								
CALLR	Call subroutine relative								
CLR	Clear		reg, M				0	1	
CP	Arithmetic Compare	tst(Reg - M)	reg	M			N	Z	C
CPL	One Complement	$A = FFH-A$	reg, M				N	Z	1
DEC	Decrement	dec Y	reg, M				N	Z	
HALT	Halt					0			
IRET	Interrupt routine return	Pop CC, A, X, PC			H	I	N	Z	C
INC	Increment	inc X	reg, M				N	Z	
JP	Absolute Jump	jp [TBL.w]							
JRA	Jump relative always								
JRT	Jump relative								
JRF	Never jump	jrf *							
JRIH	Jump if ext. interrupt = 1								
JRIL	Jump if ext. interrupt = 0								
JRH	Jump if H = 1	H = 1 ?							
JRNH	Jump if H = 0	H = 0 ?							
JRM	Jump if I = 1	I = 1 ?							
JRNM	Jump if I = 0	I = 0 ?							
JRMI	Jump if N = 1 (minus)	N = 1 ?							
JRPL	Jump if N = 0 (plus)	N = 0 ?							
JREQ	Jump if Z = 1 (equal)	Z = 1 ?							
JRNE	Jump if Z = 0 (not equal)	Z = 0 ?							
JRC	Jump if C = 1	C = 1 ?							
JRNC	Jump if C = 0	C = 0 ?							
JRULT	Jump if C = 1	Unsigned <							
JRUGE	Jump if C = 0	Jmp if unsigned >=							
JRUGT	Jump if (C + Z = 0)	Unsigned >							

INSTRUCTION GROUPS (Cont'd)

Mnemo	Description	Function/Example	Dst	Src	H	I	N	Z	C
JRULE	Jump if (C + Z = 1)	Unsigned <=							
LD	Load	dst <= src	reg, M	M, reg			N	Z	
MUL	Multiply	X,A = X * A	A, X, Y	X, Y, A	0				0
NEG	Negate (2's compl)	neg \$10	reg, M				N	Z	C
NOP	No Operation								
OR	OR operation	A = A + M	A	M			N	Z	
POP	Pop from the Stack	pop reg pop CC	reg CC	M M	H	I	N	Z	C
PUSH	Push onto the Stack	push Y	M	reg, CC					
RCF	Reset carry flag	C = 0							0
RET	Subroutine Return								
RIM	Enable Interrupts	I = 0				0			
RLC	Rotate left true C	C <= Dst <= C	reg, M				N	Z	C
RRC	Rotate right true C	C => Dst => C	reg, M				N	Z	C
RSP	Reset Stack Pointer	S = Max allowed							
SBC	Subtract with Carry	A = A - M - C	A	M			N	Z	C
SCF	Set carry flag	C = 1							1
SIM	Disable Interrupts	I = 1				1			
SLA	Shift left Arithmetic	C <= Dst <= 0	reg, M				N	Z	C
SLL	Shift left Logic	C <= Dst <= 0	reg, M				N	Z	C
SRL	Shift right Logic	0 => Dst => C	reg, M				0	Z	C
SRA	Shift right Arithmetic	Dst7 => Dst => C	reg, M				N	Z	C
SUB	Subtraction	A = A - M	A	M			N	Z	C
SWAP	SWAP nibbles	Dst[7..4] <=> Dst[3..0]	reg, M				N	Z	
TNZ	Test for Neg & Zero	tnz lbl1					N	Z	
TRAP	S/W trap	S/W interrupt				1			
WFI	Wait for Interrupt					0			
XOR	Exclusive OR	A = A XOR M	A	M			N	Z	

15 ELECTRICAL CHARACTERISTICS

15.1 PARAMETER CONDITIONS

Unless otherwise specified, all voltages are referred to V_{SS} .

15.1.1 Minimum and Maximum values

Unless otherwise specified the minimum and maximum values are guaranteed in the worst conditions of ambient temperature, supply voltage and frequencies by tests in production on 100% of the devices with an ambient temperature at $T_A=25^\circ\text{C}$ and $T_A=T_{A\text{max}}$ (given by the selected temperature range).

Data based on characterization results, design simulation and/or technology characteristics are indicated in the table footnotes and are not tested in production. Based on characterization, the minimum and maximum values refer to sample tests and represent the mean value plus or minus three times the standard deviation ($\text{mean} \pm 3\sigma$).

15.1.2 Typical values

Unless otherwise specified, typical data is based on $T_A=25^\circ\text{C}$, $V_{DD}=5\text{V}$ (for the $4.5\text{V} \leq V_{DD} \leq 5.5\text{V}$ voltage range) and $V_{DD}=3.3\text{V}$ (for the $3\text{V} \leq V_{DD} \leq 4\text{V}$ voltage range). They are given only as design guidelines and are not tested.

15.1.3 Typical curves

Unless otherwise specified, all typical curves are given only as design guidelines and are not tested.

15.1.4 Loading capacitor

The loading conditions used for pin parameter measurement are shown in [Figure 52](#).

Figure 52. Pin loading conditions

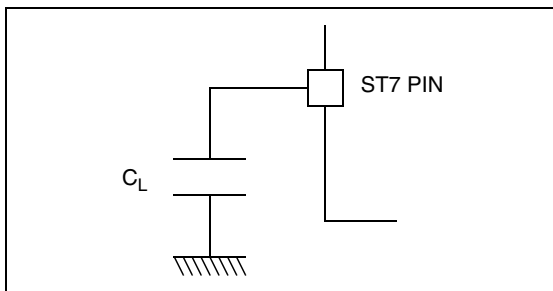

15.1.5 Pin input voltage

The input voltage measurement on a pin of the device is described in [Figure 53](#).

Figure 53. Pin input voltage

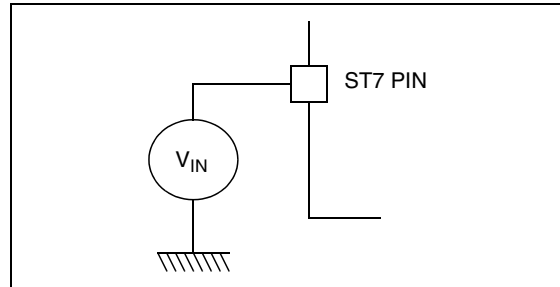

15.2 ABSOLUTE MAXIMUM RATINGS

Stresses above those listed as “absolute maximum ratings” may cause permanent damage to the device. This is a stress rating only and functional operation of the device under these condi-

tions is not implied. Exposure to maximum rating conditions for extended periods may affect device reliability.

15.2.1 Voltage Characteristics

Symbol	Ratings	Maximum value	Unit
$V_{DD} - V_{SS}$	Supply voltage	6.5	V
$V_{DDA} - V_{SSA}$	Analog Reference Voltage	6.5	
V_{IN} ^{1) & 2)}	Input voltage on true open drain pin	$V_{SS}-0.3$ to 6.5	
	Input voltage on any other pin	$V_{SS}-0.3$ to $V_{DD}+0.3$	
$ \Delta V_{DDx} $ and $ \Delta V_{SSx} $	Variations between different digital power pins	50	mV
$V_{DDx} - V_{DDA}$ $V_{SSA} - V_{SSx}$	Variations between digital and analog power pins	50	
$V_{ESD(HBM)}$	Electrostatic discharge voltage (Human Body Model)	see Section 15.7.2 "Absolute Electrical Sensitivity" on page 125	
$V_{ESD(MM)}$	Electrostatic discharge voltage (Machine Model)		

15.2.2 Current Characteristics

Symbol	Ratings	Maximum value	Unit
I_{VDD}	Total current into V_{DD} power lines (source) ³⁾	150	mA
I_{VSS}	Total current out of V_{SS} ground lines (sink) ³⁾	150	
I_{IO}	Output current sunk by any standard I/O and control pin	25	
	Output current sunk by any high sink I/O pin	50	
	Output current source by any I/Os and control pin	- 25	
$I_{INJ(PIN)}$ ^{2) & 4)}	Injected current on \overline{RESET} pin	± 5	
	Injected current on \overline{RESET} pin	± 5	
	Injected current on OSC1 and OSC2 pins	± 5	
	Injected current on any other pin ^{5) & 6)}	± 5	
$\Sigma I_{INJ(PIN)}$ ²⁾	Total injected current (sum of all I/O and control pins) ⁵⁾	± 20	

Notes:

1. Directly connecting the \overline{RESET} and I/O pins to V_{DD} or V_{SS} could damage the device if an unintentional internal reset is generated or an unexpected change of the I/O configuration occurs (for example, due to a corrupted program counter). To guarantee safe operation, this connection has to be done through a pull-up or pull-down resistor (typical: 4.7k Ω for \overline{RESET} , 10k Ω for I/Os). Unused I/O pins must be tied in the same way to V_{DD} or V_{SS} according to their reset configuration.
2. When the current limitation is not possible, the V_{IN} absolute maximum rating must be respected, otherwise refer to $I_{INJ(PIN)}$ specification. A positive injection is induced by $V_{IN} > V_{DD}$ while a negative injection is induced by $V_{IN} < V_{SS}$.
3. All power (V_{DD}) and ground (V_{SS}) lines must always be connected to the external supply.
4. Negative injection disturbs the analog performance of the device. In particular, it induces leakage currents throughout the device including the analog inputs. To avoid undesirable effects on the analog functions, care must be taken:
 - Analog input pins must have a negative injection less than 0.8mA (assuming that the impedance of the analog voltage is lower than the specified limits)
 - Pure digital pins must have a negative injection less than 1.6mA. In addition, it is recommended to inject the current as far as possible from the analog input pins.
5. When several inputs are submitted to a current injection, the maximum $\Sigma I_{INJ(PIN)}$ is the absolute sum of the positive and negative injected currents (instantaneous values). These results are based on characterization with $\Sigma I_{INJ(PIN)}$ maximum current injection on four I/O port pins of the device.
6. True open drain I/O port pins do not accept positive injection.

ABSOLUTE MAXIMUM RATINGS (Cont'd)

15.2.3 Thermal Characteristics

Symbol	Ratings	Value	Unit
T_{STG}	Storage temperature range	-65 to +150	°C
T_J	Maximum junction temperature (see Section 17 "DEVICE CONFIGURATION AND ORDERING INFORMATION" on page 143)		

15.3 OPERATING CONDITIONS

15.3.1 General Operating Conditions

Symbol	Parameter	Conditions	Min	Max	Unit
V_{DD}	Supply voltage	see Figure 54 and Figure 55	3.2	5.5	V
f_{OSC}	External clock frequency	$V_{DD} \geq 3.5V$ for ROM devices $V_{DD} \geq 4.5V$ for Flash devices	0 ¹⁾	16	MHz
		$V_{DD} \geq 3.2V$	0 ¹⁾	8	
T_A	Ambient temperature range	Suffix A version	-40	+85	°C
		Suffix B version		+105	
		Suffix C version		+125	

Figure 54. f_{OSC} Maximum Operating Frequency Versus V_{DD} Supply Voltage for ROM devices²⁾

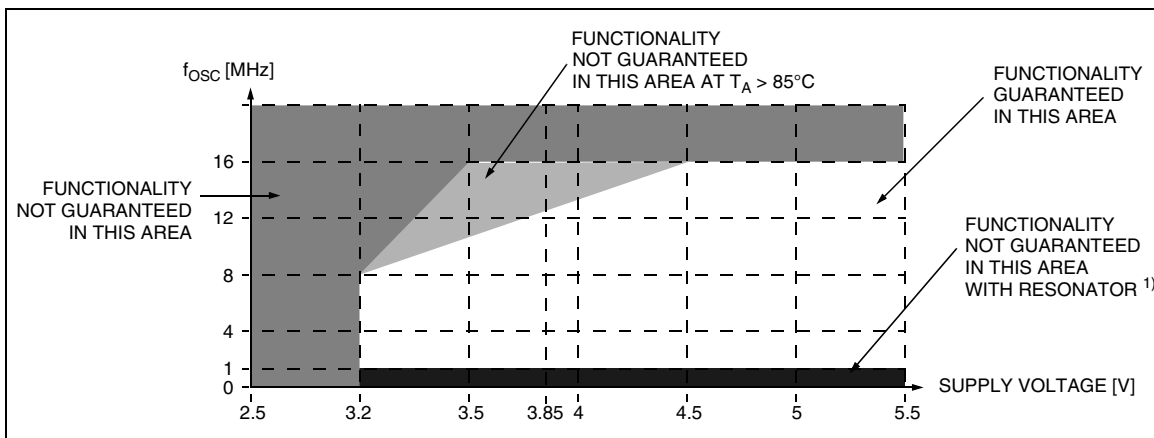
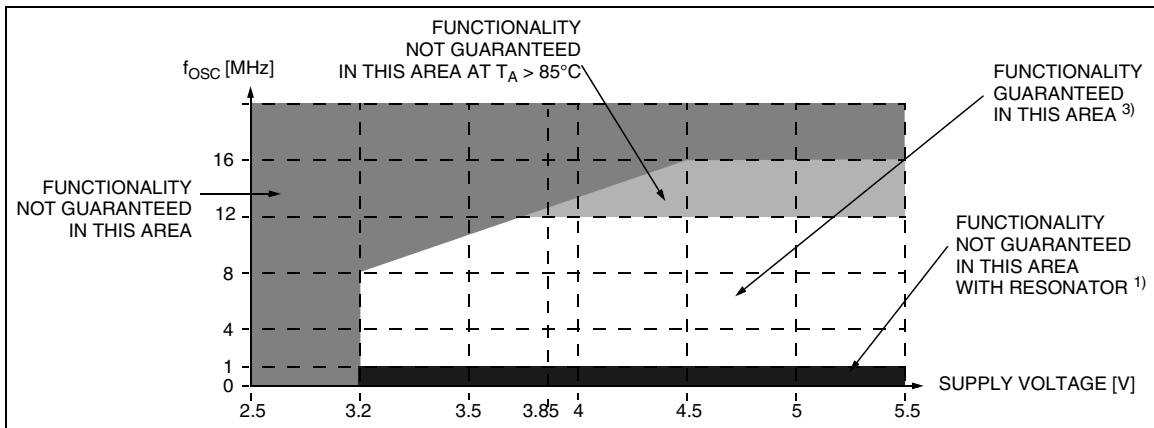

Figure 55. f_{OSC} Maximum Operating Frequency Versus V_{DD} Supply Voltage for Flash devices²⁾



Notes:

1. Guaranteed by construction. A/D operation and resonator oscillator start-up are not guaranteed below 1MHz.
2. Operating conditions with $T_A = -40$ to $+125^\circ\text{C}$.
3. Flash programming tested in production at maximum T_A with two different conditions: $V_{DD} = 5.5V$, $f_{CPU} = 6\text{MHz}$ and $V_{DD} = 3.2V$, $f_{CPU} = 4\text{MHz}$.

OPERATING CONDITIONS (Cont'd)

15.3.2 Operating Conditions with Low Voltage Detector (LVD)

Subject to general operating conditions for V_{DD} , f_{OSC} , and T_A .

Symbol	Parameter	Conditions	Min	Typ ¹⁾	Max	Unit
V_{IT+}	Reset release threshold (V_{DD} rise)	High Threshold	4.10 ²⁾	4.30	4.50	V
		Med. Threshold	3.75 ²⁾	3.90	4.05	
		Low Threshold	3.25 ²⁾	3.35	3.55	
V_{IT-}	Reset generation threshold (V_{DD} fall)	High Threshold	3.85 ²⁾	4.05	4.30	V
		Med. Threshold	3.50 ²⁾	3.65	3.95	
		Low Threshold ⁴⁾	3.00	3.10	3.35	
V_{hys}	LVD voltage threshold hysteresis	$V_{IT+}-V_{IT-}$	200	250	300	mV
V_{tPOR}	V_{DD} rise time rate ³⁾		0.2		50	V/ms
$t_g(V_{DD})$	Filtered glitch delay on V_{DD} ²⁾	Not detected by the LVD			40	ns

Figure 56. High LVD Threshold Versus V_{DD} and f_{OSC} for Flash devices³⁾

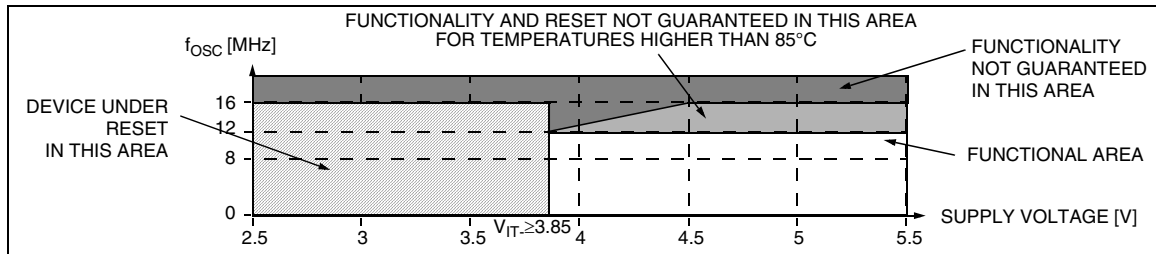

Figure 57. Medium LVD Threshold Versus V_{DD} and f_{OSC} for Flash devices³⁾

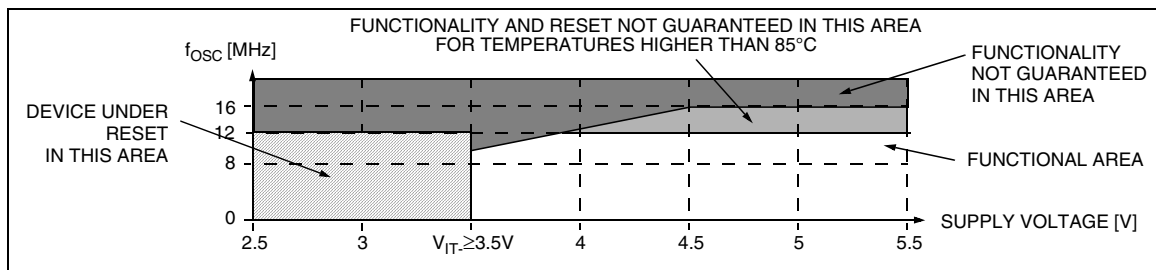
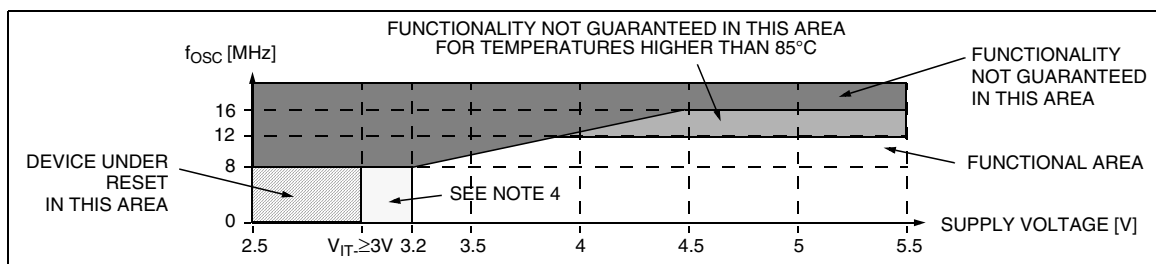

Figure 58. Low LVD Threshold Versus V_{DD} and f_{OSC} for Flash devices²⁾⁴⁾



Notes:

- LVD typical data is based on $T_A=25^\circ\text{C}$. They are given only as design guidelines and are not tested.
- Data based on characterization results, not tested in production.
- The V_{DD} rise time rate condition is needed to insure a correct device power-on and LVD reset. Not tested in production.
- If the low LVD threshold is selected, when V_{DD} falls below 3.2V, (V_{DD} minimum operating voltage), the device is guaranteed to continue functioning until it goes into reset state. The specified V_{DD} min. value is necessary in the device power on phase, but during a power down phase or voltage drop the device will function below this min. level.

FUNCTIONAL OPERATING CONDITIONS (Cont'd)

Figure 59. High LVD Threshold Versus V_{DD} and f_{OSC} for ROM devices ²⁾

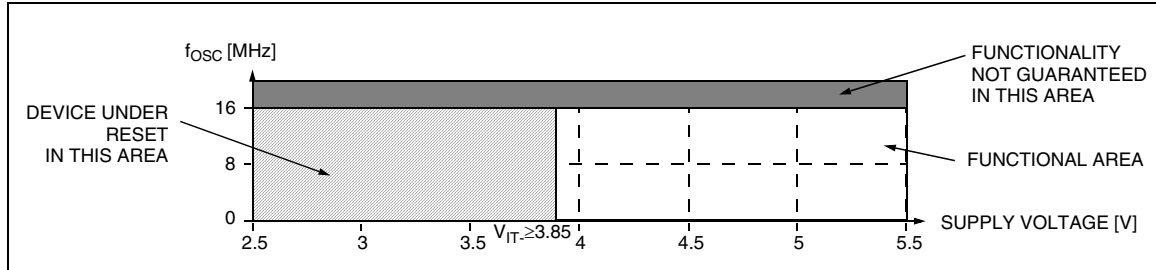

Figure 60. Medium LVD Threshold Versus V_{DD} and f_{OSC} for ROM devices ²⁾

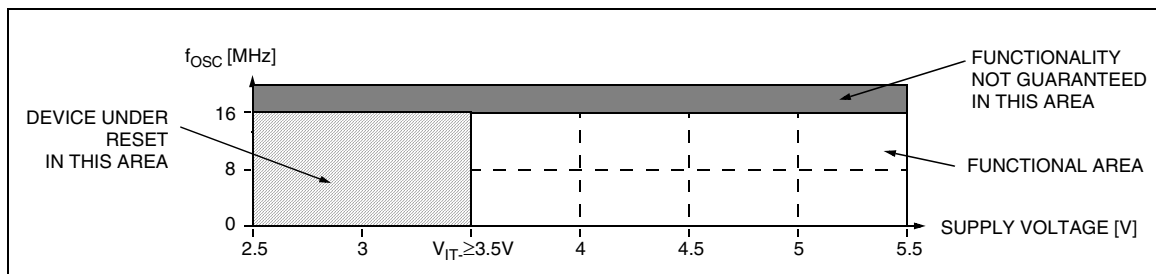
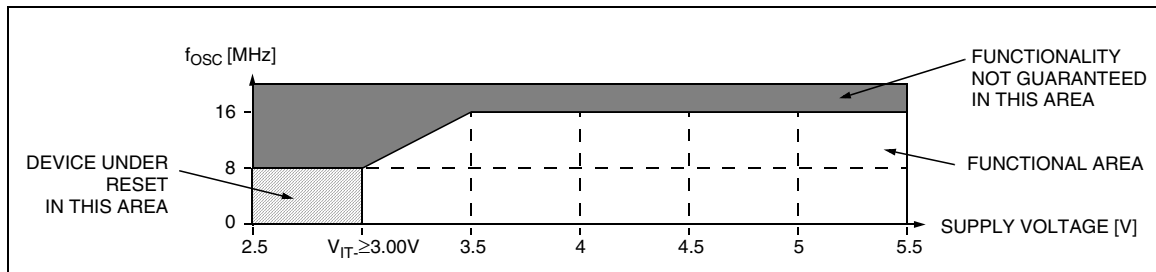

Figure 61. Low LVD Threshold Versus V_{DD} and f_{OSC} for ROM devices ²⁾³⁾



Notes:

1. LVD typical data is based on $T_A=25^\circ\text{C}$. They are given only as design guidelines and are not tested.
2. The minimum V_{DD} rise time rate is needed to insure a correct device power-on and LVD reset. Not tested in production.
3. If the low LVD threshold is selected, when V_{DD} falls below 3.2V, (V_{DD} minimum operating voltage), the device is guaranteed to continue functioning until it goes into reset state. The specified V_{DD} min. value is necessary in the device power on phase, but during a power down phase or voltage drop the device will function below this min. level.

15.4 SUPPLY CURRENT CHARACTERISTICS

The following current consumption specified for the ST7 functional operating modes over temperature range does not take into account the clock source current consumption. To get the total de-

vice consumption, the two current values must be added (except for Halt mode for which the clock is stopped).

Symbol	Parameter	Conditions	Max	Unit
$\Delta I_{DD}(\Delta T_a)$	Supply current variation vs. temperature	Constant V_{DD} and f_{CPU}	10	%

15.4.1 Run and Slow Modes

Symbol	Parameter	Conditions	Typ ¹⁾	Max ²⁾	Unit	
I_{DD}	Supply current in Run mode ³⁾ (see Figure 62)	$4.5V \leq V_{DD} \leq 5.5V$	$f_{OSC}=2MHz, f_{CPU}=1MHz$	1.2	1.8	mA
			$f_{OSC}=4MHz, f_{CPU}=2MHz$	2.1	3.5	
			$f_{OSC}=8MHz, f_{CPU}=4MHz$	3.9	7.0	
			$f_{OSC}=16MHz, f_{CPU}=8MHz$	7.4	14.0	
	Supply current in Slow mode ⁴⁾ (see Figure 63)	$4.5V \leq V_{DD} \leq 5.5V$	$f_{OSC}=2MHz, f_{CPU}=62.5kHz$	0.4	0.9	
			$f_{OSC}=4MHz, f_{CPU}=125kHz$	0.5	1.1	
			$f_{OSC}=8MHz, f_{CPU}=250kHz$	0.7	1.4	
			$f_{OSC}=16MHz, f_{CPU}=500kHz$	1.0	2.0	
Supply current in Run mode ³⁾ (see Figure 62)	$3.2V \leq V_{DD} \leq 3.6V$	$f_{OSC}=2MHz, f_{CPU}=1MHz$	0.3	1		
		$f_{OSC}=4MHz, f_{CPU}=2MHz$	0.8	1.5		
		$f_{OSC}=8MHz, f_{CPU}=4MHz$	1.6	3		
		$f_{OSC}=16MHz, f_{CPU}=8MHz$	3.5	7		
Supply current in Slow mode ⁴⁾ (see Figure 63)	$3.2V \leq V_{DD} \leq 3.6V$	$f_{OSC}=2MHz, f_{CPU}=62.5kHz$	0.1	0.3		
		$f_{OSC}=4MHz, f_{CPU}=125kHz$	0.2	0.5		
		$f_{OSC}=8MHz, f_{CPU}=250kHz$	0.3	0.6		
		$f_{OSC}=16MHz, f_{CPU}=500kHz$	0.5	1.0		

Figure 62. Typical I_{DD} in RUN vs. f_{CPU}

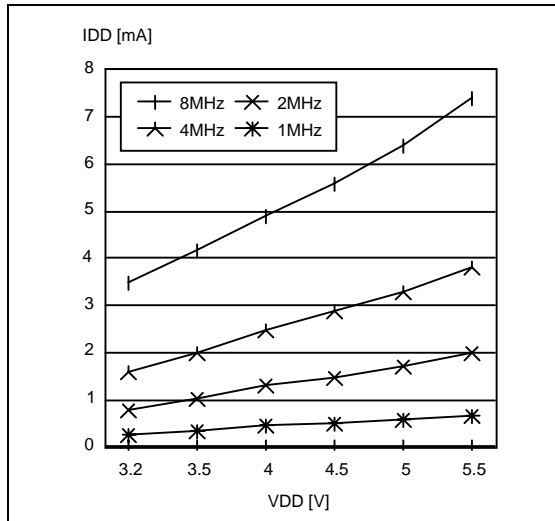
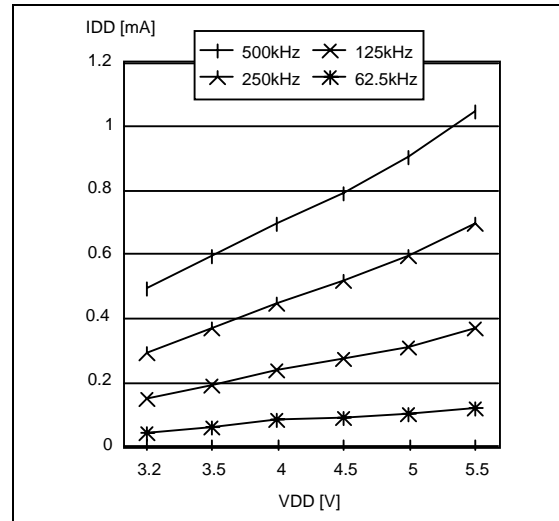

Figure 63. Typical I_{DD} in SLOW vs. f_{CPU}



Notes:

1. Typical data is based on $T_A=25^\circ C$, $V_{DD}=5V$ ($4.5V \leq V_{DD} \leq 5.5V$ range) and $V_{DD}=3.4V$ ($3.2V \leq V_{DD} \leq 3.6V$ range).
2. Data based on characterization results, tested in production at V_{DD} max. and f_{CPU} max.
3. CPU running with memory access, all I/O pins in input mode with a static value at V_{DD} or V_{SS} (no load), all peripherals in reset state; clock input (OSC1) driven by external square wave, CSS and LVD disabled.
4. Slow mode selected with f_{CPU} based on f_{OSC} divided by 32. All I/O pins in input mode with a static value at V_{DD} or V_{SS} (no load), all peripherals in reset state; clock input (OSC1) driven by external square wave, CSS and LVD disabled.

SUPPLY CURRENT CHARACTERISTICS (Cont'd)

15.4.2 Wait and Slow Wait Modes

Symbol	Parameter	Conditions		Typ ¹⁾	Max ²⁾	Unit
I _{DD}	Supply current in Wait mode ³⁾ (see Figure 64)	4.5V ≤ V _{DD} ≤ 5.5V	f _{OSC} =2MHz, f _{CPU} =1MHz	0.35	0.6	mA
			f _{OSC} =4MHz, f _{CPU} =2MHz	0.7	1.2	
	f _{OSC} =8MHz, f _{CPU} =4MHz		1.3	2.1		
	f _{OSC} =16MHz, f _{CPU} =8MHz		2.5	4.0		
Supply current in Slow Wait mode ⁴⁾ (see Figure 65)	f _{OSC} =2MHz, f _{CPU} =62.5kHz	0.05	0.1			
	f _{OSC} =4MHz, f _{CPU} =125kHz	0.1	0.2			
Supply current in Wait mode ³⁾ (see Figure 64)	3.2V ≤ V _{DD} ≤ 3.6V	f _{OSC} =2MHz, f _{CPU} =1MHz	45	100	μA	
		f _{OSC} =4MHz, f _{CPU} =2MHz	150	300		
f _{OSC} =8MHz, f _{CPU} =4MHz		300	600			
f _{OSC} =16MHz, f _{CPU} =8MHz		500	1000			
Supply current in Slow Wait mode ⁴⁾ (see Figure 65)	f _{OSC} =2MHz, f _{CPU} =62.5kHz	6	20			
	f _{OSC} =4MHz, f _{CPU} =125kHz	40	100			
	f _{OSC} =8MHz, f _{CPU} =250kHz	80	160			
	f _{OSC} =16MHz, f _{CPU} =500kHz	120	250			

Figure 64. Typical I_{DD} in WAIT vs. f_{CPU}

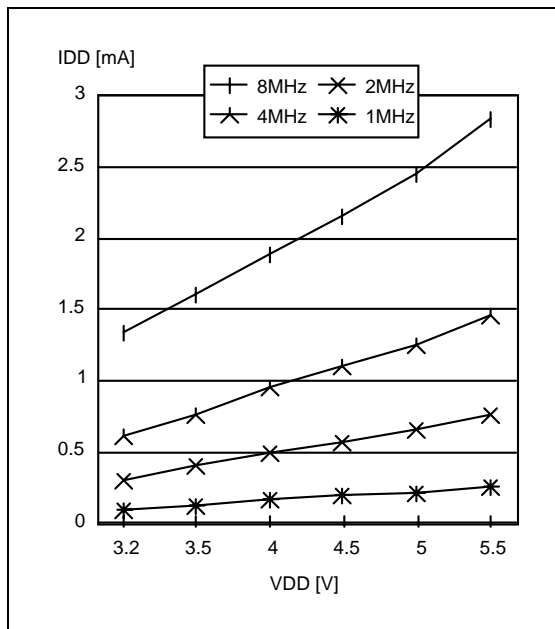
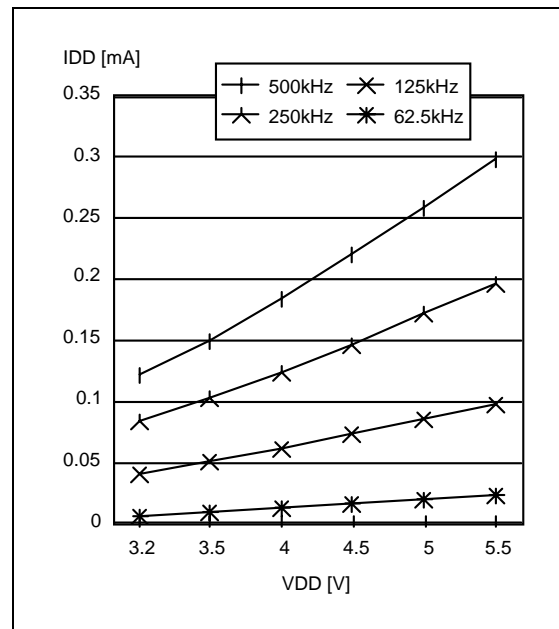

Figure 65. Typical I_{DD} in SLOW WAIT vs. f_{CPU}



Notes:

1. Typical data is based on T_A=25°C, V_{DD}=5V (4.5V ≤ V_{DD} ≤ 5.5V range) and V_{DD}=3.4V (3.2V ≤ V_{DD} ≤ 3.6V range).
2. Data based on characterization results, tested in production at V_{DD} max. and f_{CPU} max.
3. All I/O pins in input mode with a static value at V_{DD} or V_{SS} (no load), all peripherals in reset state; clock input (OSC1) driven by external square wave, CSS and LVD disabled.
4. Slow Wait mode selected with f_{CPU} based on f_{OSC} divided by 32. All I/O pins in input mode with a static value at V_{DD} or V_{SS} (no load), all peripherals in reset state; clock input (OSC1) driven by external square wave, CSS and LVD disabled.

SUPPLY CURRENT CHARACTERISTICS (Cont'd)

15.4.3 Halt and Active Halt Modes

Symbol	Parameter	Conditions		Typ ¹⁾	Max	Unit
I _{DD}	Supply current in Halt mode ²⁾	V _{DD} =5.5V	-40°C ≤ T _A ≤ +85°C	<2	10	μA
			-40°C ≤ T _A ≤ +125°C		150	
		V _{DD} =3.6V	-40°C ≤ T _A ≤ +85°C		6	
			-40°C ≤ T _A ≤ +125°C		100	
	Supply current in Active Halt mode ³⁾			50	150	

15.4.4 Supply and Clock Managers

The previous current consumption specified for the ST7 functional operating modes over temperature range does not take into account the clock source current consumption. To get the total device consumption, the two current values must be added (except for Halt mode).

Symbol	Parameter	Conditions	Typ ¹⁾	Max ⁴⁾	Unit
I _{DD(CK)}	Supply current of internal RC oscillator		500	750	μA
	Supply current of external RC oscillator ⁵⁾		525	750	
	Supply current of resonator oscillator ⁵⁾ & 6)	LP: Low power oscillator	200	400	
		MP: Medium power oscillator	300	550	
		MS: Medium speed oscillator	450	750	
HS: High speed oscillator		700	1000		
	Clock security system supply current		150	350	
I _{DD(LVD)}	LVD supply current	Halt mode	100	150	

15.4.5 On-Chip Peripherals

Symbol	Parameter	Conditions		Typ	Unit
I _{DD(TIM)}	16-bit Timer supply current ⁷⁾	f _{CPU} =8MHz	V _{DD} =3.4V	50	μA
			V _{DD} =5.0V	150	
I _{DD(SPI)}	SPI supply current ⁸⁾	f _{CPU} =8MHz	V _{DD} =3.4V	250	
			V _{DD} =5.0V	350	
I _{DD(ADC)}	ADC supply current when converting ⁹⁾	f _{ADC} =4MHz	V _{DD} =3.4V	800	
			V _{DD} =5.0V	1100	

Notes:

1. Typical data is based on T_A=25°C.
2. All I/O pins in input mode with a static value at V_{DD} or V_{SS} (no load), CSS and LVD disabled. Data based on characterization results, tested in production at V_{DD} max. and f_{CPU} max.
3. Data based on design simulation and/or technology characteristics, not tested in production. All I/O pins in input mode with a static value at V_{DD} or V_{SS} (no load); clock input (OSC1) driven by external square wave, LVD disabled.
4. Data based on characterization results, not tested in production.
5. Data based on characterization results done with the external components specified in [Section 15.5.3](#) and [Section 15.5.4](#), not tested in production.
6. As the oscillator is based on a current source, the consumption does not depend on the voltage.
7. Data based on a differential I_{DD} measurement between reset configuration (timer counter running at f_{CPU}/4) and timer counter stopped (selecting external clock capability). Data valid for one timer.
8. Data based on a differential I_{DD} measurement between reset configuration and a permanent SPI master communication (data sent equal to 55h).
9. Data based on a differential I_{DD} measurement between reset configuration and continuous A/D conversions.

15.5 CLOCK AND TIMING CHARACTERISTICS

Subject to general operating conditions for V_{DD} , f_{OSC} , and T_A .

15.5.1 General Timings

Symbol	Parameter	Conditions	Min	Typ ¹⁾	Max	Unit
$t_{c(INST)}$	Instruction cycle time		2	3	12	t_{CPU}
		$f_{CPU}=8MHz$	250	375	1500	ns
$t_{v(IT)}$	Interrupt reaction time ²⁾ $t_{v(IT)} = \Delta t_{c(INST)} + 10$		10		22	t_{CPU}
		$f_{CPU}=8MHz$	1.25		2.75	μs

15.5.2 External Clock Source

Symbol	Parameter	Conditions	Min	Typ	Max	Unit
V_{OSC1H}	OSC1 input pin high level voltage	see Figure 66	$0.7 \times V_{DD}$		V_{DD}	V
V_{OSC1L}	OSC1 input pin low level voltage		V_{SS}		$0.3 \times V_{DD}$	
$t_{w(OSC1H)}$ $t_{w(OSC1L)}$	OSC1 high or low time ³⁾		15			ns
$t_r(OSC1)$ $t_f(OSC1)$	OSC1 rise or fall time ³⁾				15	
I_L	OSCx Input leakage current	$V_{SS} \leq V_{IN} \leq V_{DD}$			± 1	μA

Figure 66. Typical Application with an External Clock Source

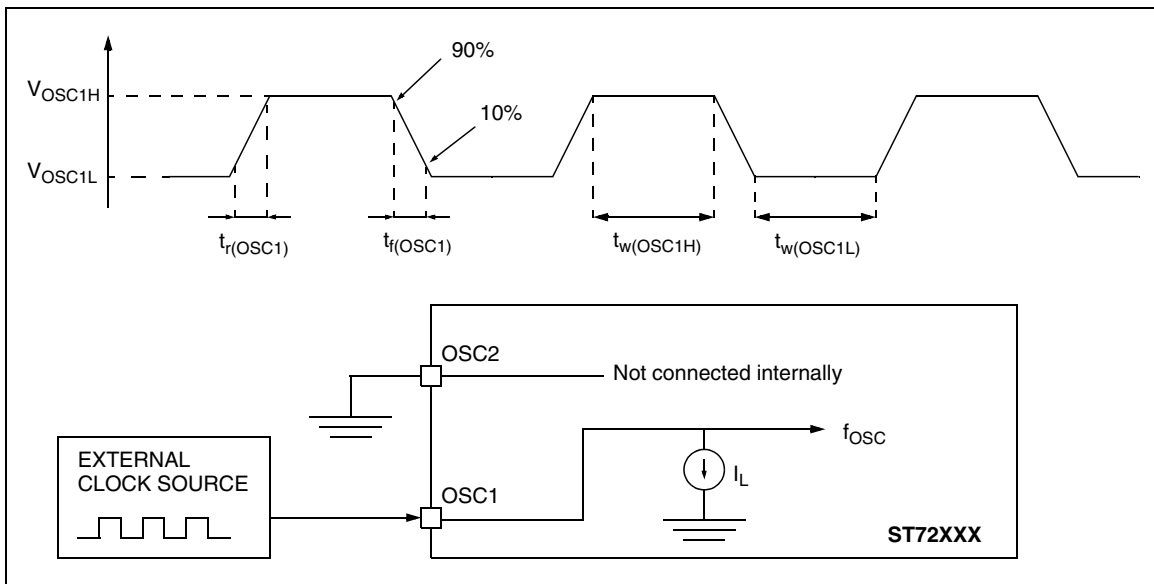

Notes:

1. Data based on typical application software.
2. Time measured between interrupt event and interrupt vector fetch. $\Delta t_{c(INST)}$ is the number of t_{CPU} cycles needed to finish the current instruction execution.
3. Data based on design simulation and/or technology characteristics, not tested in production.

CLOCK AND TIMING CHARACTERISTICS (Cont'd)

15.5.3 Crystal and Ceramic Resonator Oscillators

The ST7 internal clock can be supplied with four different Crystal/Ceramic resonator oscillators. All the information given in this paragraph are based on characterization results with specified typical external components. In the application, the resonator and the load capacitors have to be placed as

close as possible to the oscillator pins in order to minimize output distortion and start-up stabilization time. Refer to the crystal/ceramic resonator manufacturer for more details (frequency, package, accuracy...).

Symbol	Parameter	Conditions	Min	Max	Unit
f_{OSC}	Oscillator Frequency ³⁾	LP: Low power oscillator MP: Medium power oscillator MS: Medium speed oscillator HS: High speed oscillator	1 >2 >4 >8	2 4 8 16	MHz
R_F	Feedback resistor		20	40	k Ω
C_{L1} C_{L2}	Recommended load capacitance versus equivalent serial resistance of the crystal or ceramic resonator (R_S)	$R_S=200\Omega$ LP oscillator $R_S=200\Omega$ MP oscillator $R_S=200\Omega$ MS oscillator $R_S=100\Omega$ HS oscillator	38 32 18 15	56 46 26 21	pF
i_2	OSC2 driving current	$V_{DD}=5V$ $V_{IN}=V_{SS}$ LP oscillator MP oscillator MS oscillator HS oscillator	40 110 180 400	100 190 360 700	μA

15.5.3.1 Typical Crystal Resonators

Option Byte Config.	Reference	Freq.	Characteristic ¹⁾	C_{L1} [pF]	C_{L2} [pF]	$t_{SU(osc)}$ [ms] ²⁾
LP	S-200-30-30/50	2MHz	$\Delta f_{OSC}=[\pm 30ppm_{25^\circ C}, \pm 30ppm_{\Delta Ta}]$, Typ. $R_S=200\Omega$	33	34	10~15
MP	SS3-400-30-30/30	4MHz	$\Delta f_{OSC}=[\pm 30ppm_{25^\circ C}, \pm 30ppm_{\Delta Ta}]$, Typ. $R_S=60\Omega$	33	34	7~10
MS	SS3-800-30-30/30	8MHz	$\Delta f_{OSC}=[\pm 30ppm_{25^\circ C}, \pm 30ppm_{\Delta Ta}]$, Typ. $R_S=25\Omega$	33	34	2.5~3
HS	SS3-1600-30-30/30	16MHz	$\Delta f_{OSC}=[\pm 30ppm_{25^\circ C}, \pm 30ppm_{\Delta Ta}]$, Typ. $R_S=15\Omega$	33	34	1~1.5

Figure 67. Application with a Crystal Resonator

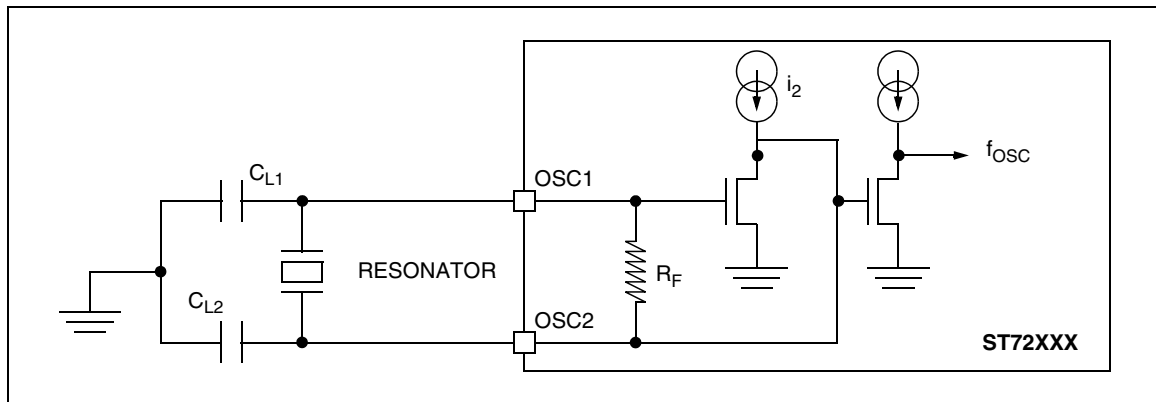

Notes:

1. Resonator characteristics given by the crystal manufacturer.
2. $t_{SU(OSC)}$ is the typical oscillator start-up time measured between $V_{DD}=2.8V$ and the fetch of the first instruction (with a quick V_{DD} ramp-up from 0 to 5V (<50 μs)).
3. The oscillator selection can be optimized in terms of supply current using a high quality resonator with small R_S value. Refer to crystal manufacturer for more details.

CLOCK AND TIMING CHARACTERISTICS (Cont'd)

15.5.3.2 Typical Ceramic Resonators

Symbol	Parameter	Conditions		Typ	Unit
$t_{SU(osc)}$	Ceramic resonator start-up time	LP	2MHz	4.2	ms
		MP	4MHz	2.1	
		MS	8MHz	1.1	
		HS	16MHz	0.7	

Note:

$t_{SU(osc)}$ is the typical oscillator start-up time measured between $V_{DD}=2.8V$ and the fetch of the first instruction (with a quick V_{DD} ramp-up from 0 to 5V (<50 μ s)).

Figure 68. Application with Ceramic Resonator

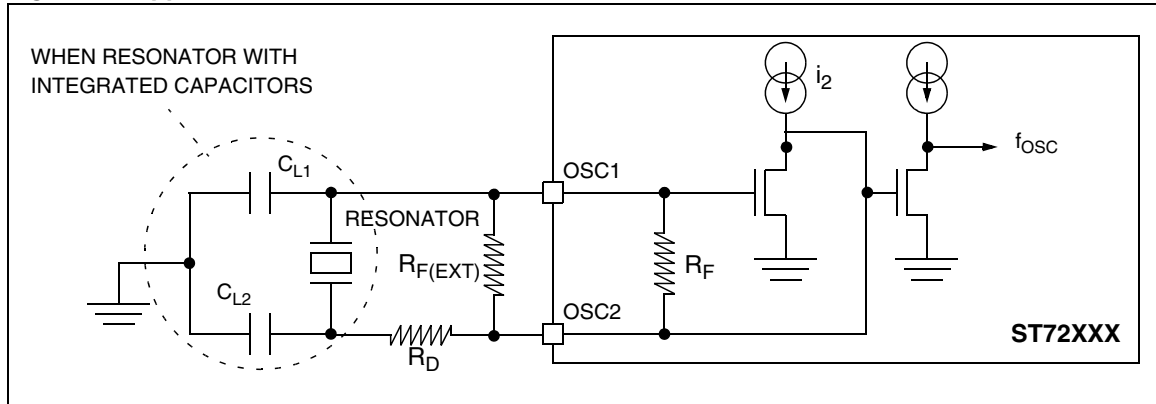

Notes:

1. Resonator characteristics given by the ceramic resonator manufacturer.
2. $t_{SU(OSC)}$ is the typical oscillator start-up time measured between $V_{DD}=2.8V$ and the fetch of the first instruction (with a quick V_{DD} ramp-up from 0 to 5V (<50 μ s)).
3. The oscillator selection can be optimized in terms of supply current using a high quality resonator with small R_S value. Refer to [Table 23](#) and [Table 24](#) and to the ceramic resonator manufacturer's documentation for more details.

CLOCK AND TIMING CHARACTERISTICS (Cont'd)

Table 23. Typical Ceramic Resonators

Option Byte Config.	f _{osc} (MHz)	Resonator Part Number ¹⁾	C _{L1} [pF] ³	C _{L2} [pF] ³	R _{FEXT} kΩ	R _D [kΩ]
LP	1	CSB1000JA	100	100	Open	3.3
		CSTCC2.00MGA0H6				
MP	2	CSTS0200MGA06	(47)	(47)	Open	0
		CSTCC2.00MGA0H6				
	4	CSTS0400MGA06				
		CSTCC4.00MGA0H6				
MS	4	CSTS0400MGA06				
		CSTCC4.00MGA0H6				
	8	CSTS0800MGA06				
		CSTCC8.00MGA0H6				
HS	8	CSTS0800MGA06	30	30	10	
		CSTCC8.00MGA0H6				
	10	CST10.0MTWA				
		CSTCC10.0MGA				
	12	CST12.0MTWA				
		CSTCS12.0MTA				
	16 ²⁾	CSA16.00MXZA040	15	15		
		CST16.00MXWA0C3	(15)	(15)		
CSACV16.00MXA040Q		15	15			
CSTCV16.00MXA0H3Q		(15)	(15)			

Table 24. Resonator Frequency Correlation Factor

Option Byte Config.	Resonator ¹⁾	Correlation %	Reference IC
LP	CSB1000JA	+0.03	4069UBE
	CSTS0200MGA06	-0.20	74HCU04
	CSTCC2.00MGA0H6	-0.16	
MP	CSTS0200MGA06	-0.21	
	CSTCC2.00MGA0H6	-0.19	
	CSTS0400MGA06	0.02	
	CSTCC4.00MGA0H6	-0.05	
Option Byte Config.	Resonator ¹⁾	Correlation %	Reference IC
MS	CSTS0400MGA06	-0.03	74HCU04
	CSTCC4.00MGA0H6	-0.05	
	CSTS0800MGA06	+0.03	
	CSTCC4.00MGA0H6	+0.02	
HS	CSTS0800MGA06	+0.02	4069UBE
	CSTCC8.00MGA0H6	+0.01	
	CSTS10.0MTWA	+0.38	
	CSTCC10.0MGA	+0.61	
	CST12.0MTWA	+0.38	74HCU04
	CSTCS12.0MTA	+0.42	
	CSA16.00MXZA040	+0.10	
	CSACV16.00MXA040Q	+0.08	

Notes:

1. Murata Ceralock
2. V_{DD} 4.5 to 5.5V
3. Values in parentheses refer to the capacitors integrated in the resonator

CLOCK CHARACTERISTICS (Cont'd)

15.5.4 RC Oscillators

The ST7 internal clock can be supplied with an RC oscillator. This oscillator can be used with internal or external components (selectable by option byte).

Symbol	Parameter	Conditions	Min	Typ	Max	Unit
f _{OSC}	Internal RC oscillator frequency ¹⁾	see Figure 70	3.60		5.10	MHz
	External RC oscillator frequency ²⁾		1		14	
t _{SU(OSC)}	Internal RC Oscillator Start-up Time ³⁾			2.0		ms
	External RC Oscillator Start-up Time ³⁾	R _{EX} = 47KΩ, C _{EX} = "0"pF		1.0		
		R _{EX} = 47KΩ, C _{EX} = 100pF		6.5		
		R _{EX} = 10KΩ, C _{EX} = 6.8pF		0.7		
R _{EX}	Oscillator external resistor ⁴⁾	see Figure 71	10		47	KΩ
C _{EX}	Oscillator external capacitor		0 ⁵⁾		470	pF

Figure 69. Typical Application with RC oscillator

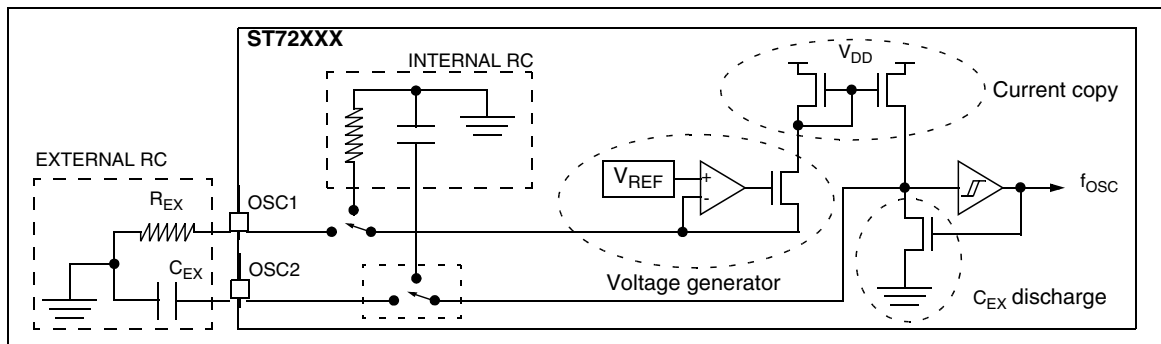

Figure 70. Typical Internal RC Oscillator

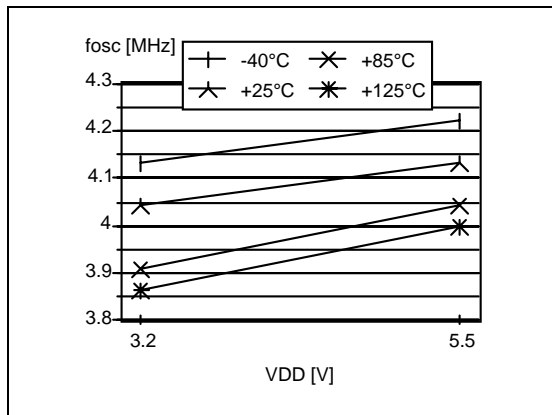
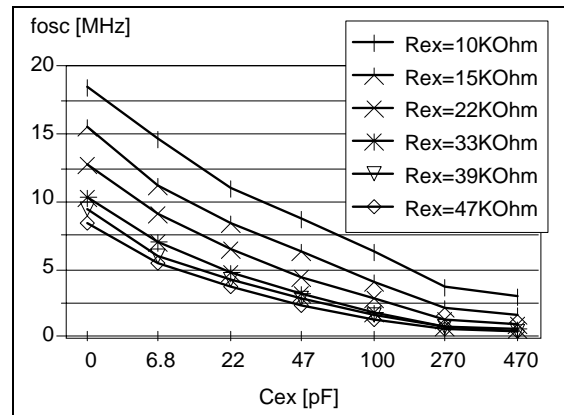

Figure 71. Typical External RC Oscillator



Notes:

1. Data based on characterization results.
2. Guaranteed frequency range with the specified C_{EX} and R_{EX} ranges taking into account the device process variation. Data based on design simulation.
3. Data based on characterization results done with V_{DD} nominal at 5V, not tested in production.
4. R_{EX} must have a positive temperature coefficient (ppm/°C), carbon resistors should therefore not be used.
5. **Important:** When no external C_{EX} is applied, the capacitance to be considered is the global parasitic capacitance which is subject to high variation (package, application...). In this case, the RC oscillator frequency tuning has to be done by trying out several resistor values.

CLOCK CHARACTERISTICS (Cont'd)

15.5.5 Clock Security System (CSS)

Symbol	Parameter	Conditions	Min	Typ	Max	Unit
f _{SFOSC}	Safe Oscillator Frequency ¹⁾	T _A =25°C, V _{DD} =5.0V	250	340	550	kHz
		T _A =25°C, V _{DD} =3.4V	190	260	450	
f _{GFOSC}	Glitch Filtered Frequency ²⁾			30		MHz

Figure 72. Typical Safe Oscillator Frequencies

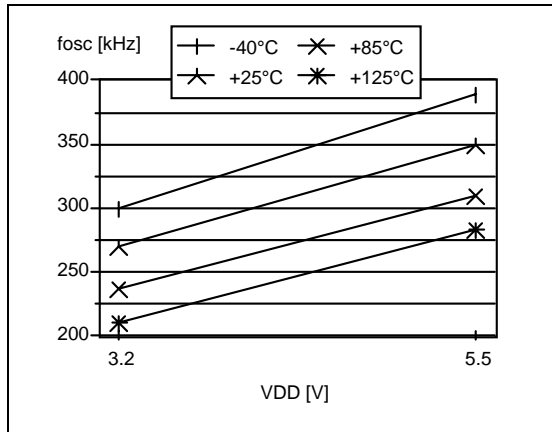

Note:

1. Data based on characterization results, tested in production between 90kHz and 600kHz.
2. Filtered glitch on the f_{OSC} signal. See functional description in [Section 8.4 on page 32](#) for more details.

15.6 MEMORY CHARACTERISTICS

15.6.1 RAM and Hardware Registers

Symbol	Parameter	Conditions	Min	Typ	Max	Unit
V _{RM}	Data retention mode ¹⁾	Halt mode (or RESET)	1.6			V

15.6.2 EEPROM Data Memory

Symbol	Parameter	Conditions	Min	Typ	Max	Unit
t _{prog}	Programming time for 1~16 bytes ³⁾	-40°C ≤ T _A ≤ +85°C			20	ms
		-40°C ≤ T _A ≤ +125°C			25	
t _{ret}	Data retention ⁵⁾	T _A = +55°C ⁴⁾	20			years
N _{RW}	Write erase cycles ⁵⁾	T _A = +25°C	300000			cycles

15.6.3 Flash Program Memory

Symbol	Parameter	Conditions	Min	Typ	Max	Unit
T _{A(prog)}	Programming temperature range ²⁾		0	25	70	°C
t _{prog}	Programming time for 1~16 bytes ³⁾	T _A = +25°C		8	25	ms
	Programming time for 4 or 8Kbytes	T _A = +25°C		2.1	6.4	sec
t _{ret}	Data retention ⁵⁾	T _A = +55°C ⁴⁾	20			years
N _{RW}	Write erase cycles ⁵⁾	T _A = +25°C	100			cycles

Notes:

1. Minimum V_{DD} supply voltage without losing data stored in RAM (in Halt mode or under RESET) or in hardware registers (only in Halt mode). Guaranteed by construction, not tested in production.
2. Data based on characterization results, tested in production at T_A = 25°C.
3. Up to 16 bytes can be programmed at a time for a 4 Kbytes Flash block (then up to 32 bytes at a time for an 8K device)
4. The data retention time increases when the T_A decreases.
5. Data based on reliability test results and monitored in production.

15.7 EMC CHARACTERISTICS

Susceptibility tests are performed on a sample basis during product characterization.

15.7.1 Functional EMS

(Electromagnetic Susceptibility)

Based on a simple running application on the product (toggling two LEDs through I/O ports), the product is stressed by two electromagnetic events until a failure occurs (indicated by the LEDs).

- **ESD:** Electrostatic Discharge (positive and negative) is applied on all pins of the device until a functional disturbance occurs. This test conforms with the IEC 1000-4-2 standard.
- **FTB:** A Burst of Fast Transient voltage (positive and negative) is applied to V_{DD} and V_{SS} through a 100pF capacitor, until a functional disturbance occurs. This test conforms with the IEC 1000-4-4 standard.

A device reset allows normal operations to be resumed.

Symbol	Parameter	Conditions	Neg ¹⁾	Pos ¹⁾	Unit
V_{FESD}	Voltage limits to be applied on any I/O pin to induce a functional disturbance	$V_{DD}=5V, T_A=+25^{\circ}C, f_{OSC}=8MHz$ conforms to IEC 1000-4-2	-1	1	kV
V_{FFTB}	Fast transient voltage burst limits to be applied through 100pF on V_{DD} and V_{DD} pins to induce a functional disturbance	$V_{DD}=5V, T_A=+25^{\circ}C, f_{OSC}=8MHz$ conforms to IEC 1000-4-4	-4	4	

Figure 73. EMC Recommended star network power supply connection ²⁾

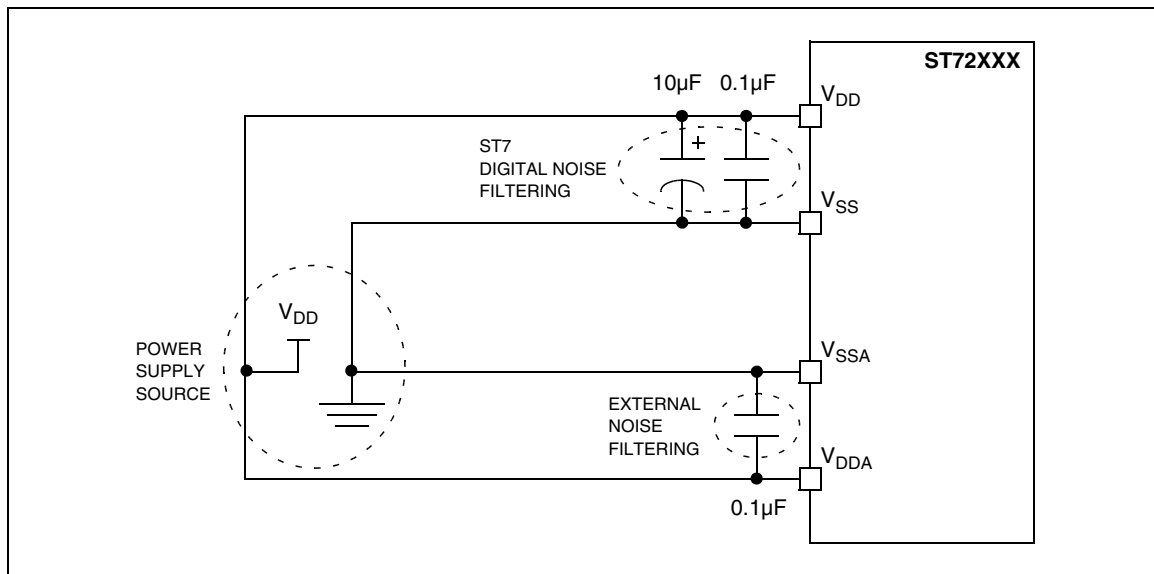

Notes:

1. Data based on characterization results, not tested in production.
2. The suggested 10µF and 0.1µF decoupling capacitors on the power supply lines are proposed as a good price vs. EMC performance trade-off. They have to be put as close as possible to the device power supply pins. Other EMC recommendations are given in other sections (I/Os, RESET, OSCx pin characteristics).

EMC CHARACTERISTICS (Cont'd)

15.7.2 Absolute Electrical Sensitivity

Based on three different tests (ESD, LU and DLU) using specific measurement methods, the product is stressed in order to determine its performance in terms of electrical sensitivity. For more details, refer to the AN1181 ST7 application note.

15.7.2.1 Electrostatic Discharge (ESD)

Electrostatic Discharges (3 positive then 3 negative pulses separated by 1 second) are applied to the pins of each sample according to each pin combination. The sample size depends of the number of supply pins of the device (3 parts*(n+1) supply pin). Two models are usually simulated: Human Body Model and Machine Model. This test conforms to the JESD22-A114A/A115A standard. See Figure 74 and the following test sequences.

Human Body Model Test Sequence

- C_L is loaded through S1 by the HV pulse generator.
- S1 switches position from generator to R.
- A discharge from C_L through R (body resistance) to the ST7 occurs.
- S2 must be closed 10 to 100ms after the pulse delivery period to ensure the ST7 is not left in charge state. S2 must be opened at least 10ms prior to the delivery of the next pulse.

Machine Model Test Sequence

- C_L is loaded through S1 by the HV pulse generator.
- S1 switches position from generator to ST7.
- A discharge from C_L to the ST7 occurs.
- S2 must be closed 10 to 100ms after the pulse delivery period to ensure the ST7 is not left in charge state. S2 must be opened at least 10ms prior to the delivery of the next pulse.
- R (machine resistance), in series with S2, ensures a slow discharge of the ST7.

Absolute Maximum Ratings

Symbol	Ratings	Conditions	Maximum value ¹⁾	Unit
$V_{ESD(HBM)}$	Electrostatic discharge voltage (Human Body Model)	$T_A=+25^{\circ}C$	3000	V
$V_{ESD(MM)}$	Electrostatic discharge voltage (Machine Model)	$T_A=+25^{\circ}C$	400	

Figure 74. Typical Equivalent ESD Circuits

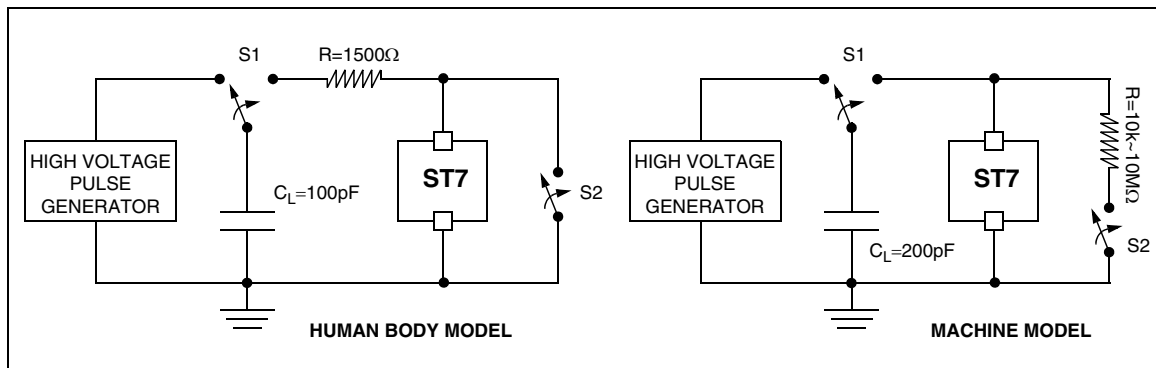

Notes:

1. Data based on characterization results, not tested in production.



EMC CHARACTERISTICS (Cont'd)

15.7.2.2 Static and Dynamic Latch-Up

- **LU:** 3 complementary static tests are required on 10 parts to assess the latch-up performance. A supply overvoltage (applied to each power supply pin), a current injection (applied to each input, output and configurable I/O pin) and a power supply switch sequence are performed on each sample. This test conforms to the EIA/JESD 78 IC latch-up standard. For more details, refer to the AN1181 ST7 application note.
- **DLU:** Electrostatic Discharges (one positive then one negative test) are applied to each pin of three samples when the micro is running to assess the latch-up performance in dynamic mode. Power supplies are set to the typical values, the oscillator is connected as near as possible to the pins of the micro and the component is put in reset mode. This test conforms to the IEC1000-4-2 and SAEJ1752/3 standards and is described in Figure 75. For more details, refer to the AN1181 ST7 application note.

15.7.2.3 Designing hardened software to avoid noise problems

EMC characterization and optimization are performed at component level with a typical application environment and simplified MCU software. It

should be noted that good EMC performance is highly dependent on the user application and the software in particular.

Therefore it is recommended that the user applies EMC software optimization and prequalification tests in relation with the EMC level requested for his application.

Software recommendations:

The software flowchart must include the management of runaway conditions such as:

- Corrupted program counter
- Unexpected reset
- Critical Data corruption (control registers...)

Prequalification trials:

Most of the common failures (unexpected reset and program counter corruption) can be reproduced by manually forcing a low state on the $\overline{\text{RESET}}$ pin or the Oscillator pins for 1 second.

To complete these trials, ESD stress can be applied directly on the device, over the range of specification values. When unexpected behavior is detected, the software can be hardened to prevent unrecoverable errors occurring (see application note AN1015).

Electrical Sensitivities

Symbol	Parameter	Conditions	Class ¹⁾
LU	Static latch-up class	$T_A=+25^\circ\text{C}$ $T_A=+85^\circ\text{C}$	A A
DLU	Dynamic latch-up class	$V_{DD}=5.5\text{V}$, $f_{OSC}=4\text{MHz}$, $T_A=+25^\circ\text{C}$	A

Figure 75. Simplified Diagram of the ESD Generator for DLU

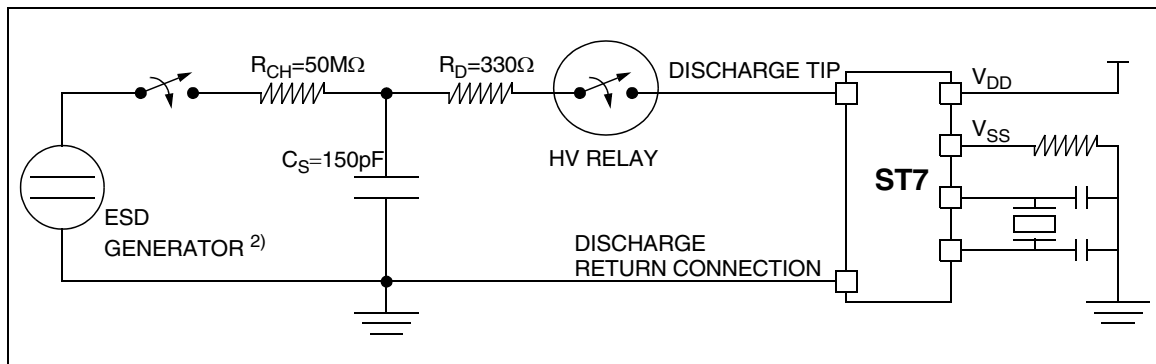

Notes:

1. Class description: A Class is an STMicroelectronics internal specification. All its limits are higher than the JEDEC specifications, that means when a device belongs to Class A it exceeds the JEDEC standard. B Class strictly covers all the JEDEC criteria (international standard).
2. Schaffner NSG435 with a pointed test finger.

EMC CHARACTERISTICS (Cont'd)

15.7.3 ESD Pin Protection Strategy

To protect an integrated circuit against Electrostatic Discharge the stress must be controlled to prevent degradation or destruction of the circuit elements. The stress generally affects the circuit elements which are connected to the pads but can also affect the internal devices when the supply pads receive the stress. The elements to be protected must not receive excessive current, voltage or heating within their structure.

An ESD network combines the different input and output ESD protections. This network works, by allowing safe discharge paths for the pins subjected to ESD stress. Two critical ESD stress cases are presented in Figure 76 and Figure 77 for standard pins and in Figure 78 and Figure 79 for true open drain pins.

Standard Pin Protection

To protect the output structure the following elements are added:

- A diode to V_{DD} (3a) and a diode from V_{SS} (3b)
- A protection device between V_{DD} and V_{SS} (4)

To protect the input structure the following elements are added:

- A resistor in series with the pad (1)
- A diode to V_{DD} (2a) and a diode from V_{SS} (2b)
- A protection device between V_{DD} and V_{SS} (4)

Figure 76. Positive Stress on a Standard Pad vs. V_{SS}

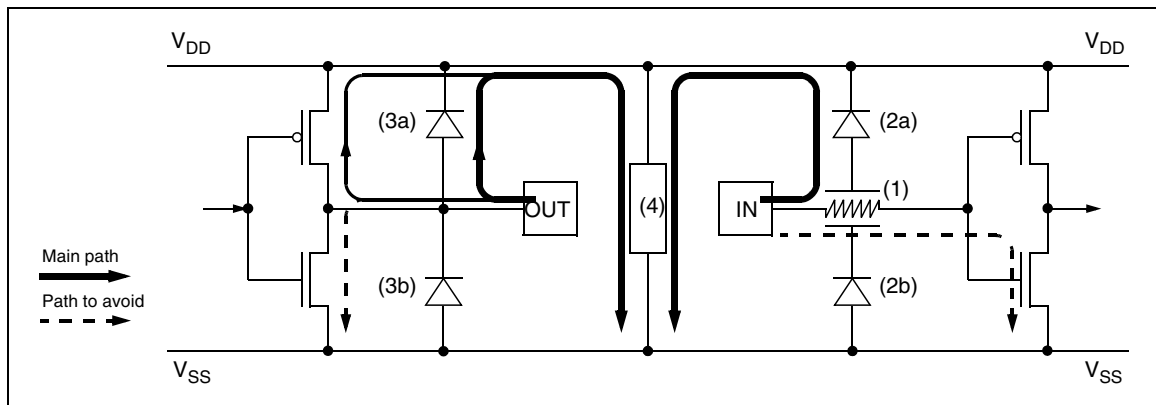
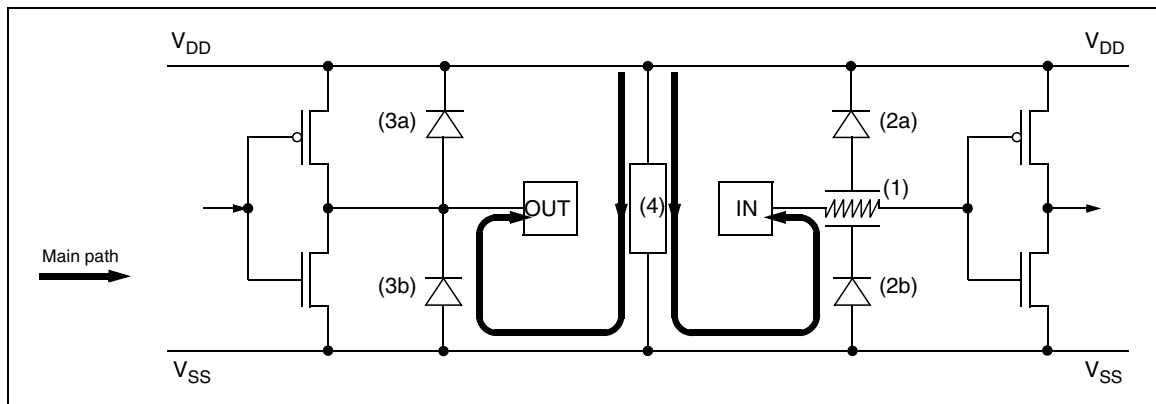

Figure 77. Negative Stress on a Standard Pad vs. V_{DD}



EMC CHARACTERISTICS (Cont'd)

True Open Drain Pin Protection

The centralized protection (4) is not involved in the discharge of the ESD stresses applied to true open drain pads due to the fact that a P-Buffer and diode to V_{DD} are not implemented. An additional local protection between the pad and V_{SS} (5a and 5b) is implemented to completely absorb the positive ESD discharge.

Multisupply Configuration

When several types of ground (V_{SS} , V_{SSA} , ...) and power supply (V_{DD} , V_{DDA} , ...) are available for any reason (better noise immunity...), the structure shown in Figure 80 is implemented to protect the device against ESD.

Figure 78. Positive Stress on a True Open Drain Pad vs. V_{SS}

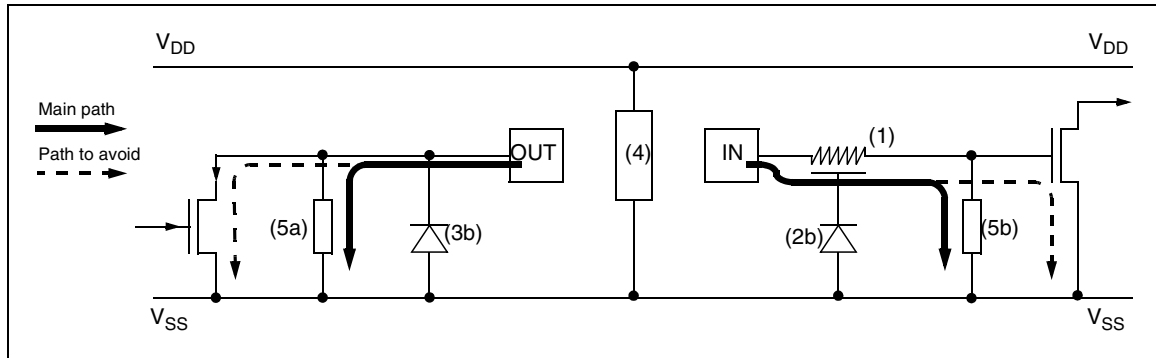

Figure 79. Negative Stress on a True Open Drain Pad vs. V_{DD}

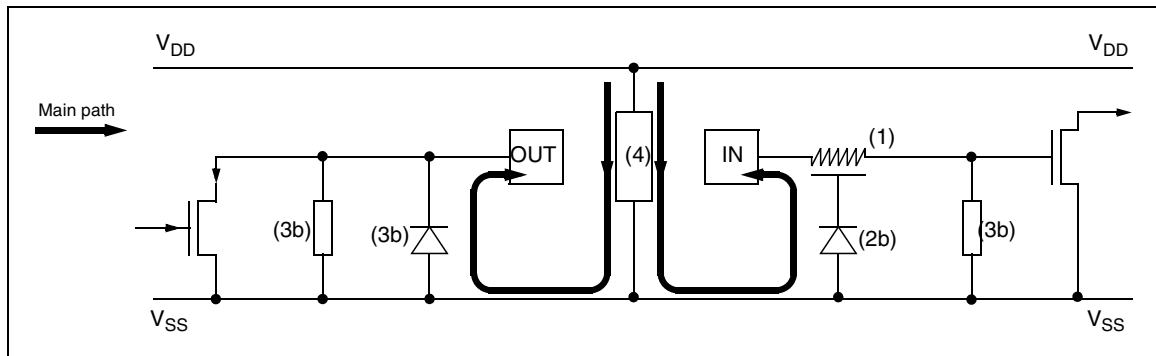
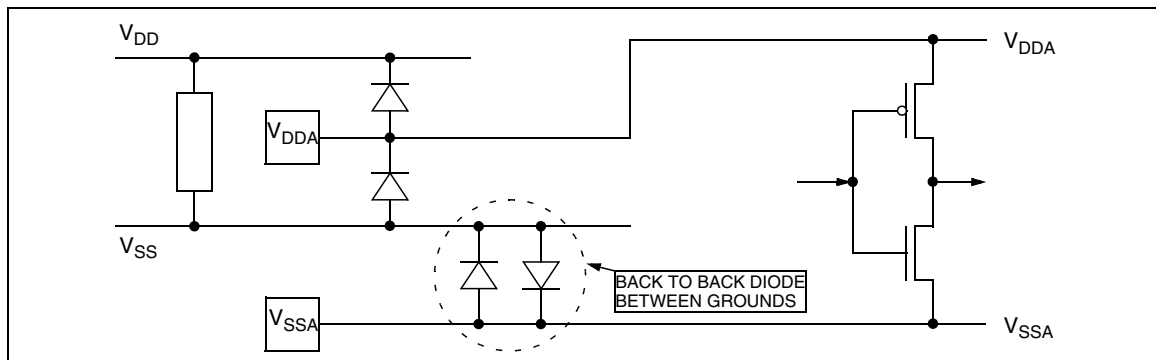

Figure 80. Multisupply Configuration



15.8 I/O PORT PIN CHARACTERISTICS

15.8.1 General Characteristics

Subject to general operating conditions for V_{DD} , f_{OSC} , and T_A unless otherwise specified.

Symbol	Parameter	Conditions	Min	Typ ¹⁾	Max	Unit	
V_{IL}	Input low level voltage ²⁾				$0.3 \times V_{DD}$	V	
V_{IH}	Input high level voltage ²⁾		$0.7 \times V_{DD}$				
V_{hys}	Schmitt trigger voltage hysteresis ³⁾			400		mV	
I_L	Input leakage current	$V_{SS} \leq V_{IN} \leq V_{DD}$			± 1	μA	
I_S	Static current consumption ⁴⁾	Floating input mode			200		
R_{PU}	Weak pull-up equivalent resistor ⁵⁾	$V_{IN} = V_{SS}$	$V_{DD} = 5V$ $V_{DD} = 3.3V$	62 170	120 200	250 300	$k\Omega$
C_{IO}	I/O pin capacitance			5		pF	
$t_{f(I/O)out}$	Output high to low level fall time ⁶⁾	$C_L = 50pF$ Between 10% and 90%		25		ns	
$t_{r(I/O)out}$	Output low to high level rise time ⁶⁾			25			
$t_{w(IT)in}$	External interrupt pulse time ⁷⁾		1			t_{CPU}	

Figure 81. Two typical Applications with unused I/O Pin

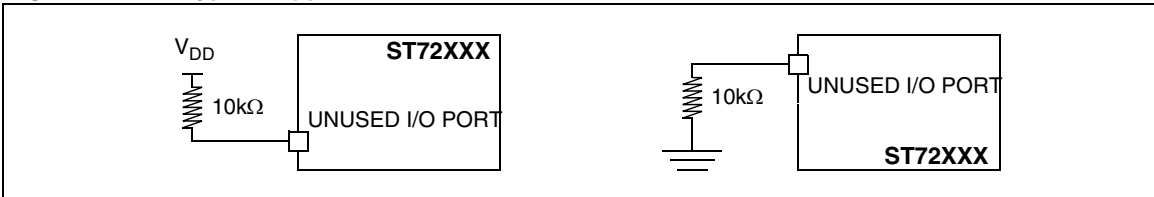
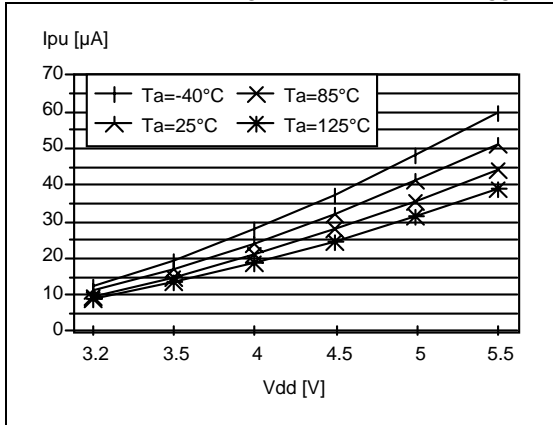

Figure 82. Typical I_{PU} vs. V_{DD} with $V_{IN}=V_{SS}$



Notes:

1. Unless otherwise specified, typical data is based on $T_A = 25^\circ C$ and $V_{DD} = 5V$.
2. Data based on characterization results, not tested in production.
3. Hysteresis voltage between Schmitt trigger switching levels. Based on characterization results, not tested.
4. Configuration not recommended, all unused pins must be kept at a fixed voltage: using the output mode of the I/O for example or an external pull-up or pull-down resistor (see Figure 81). Data based on design simulation and/or technology characteristics, not tested in production.
5. The R_{PU} pull-up equivalent resistor is based on a resistive transistor (corresponding I_{PU} current characteristics described in Figure 82). This data is based on characterization results, tested in production at V_{DD} max.
6. Data based on characterization results, not tested in production.
7. To generate an external interrupt, a minimum pulse width has to be applied on an I/O port pin configured as an external interrupt source.

I/O PORT PIN CHARACTERISTICS (Cont'd)

15.8.2 Output Driving Current

Subject to general operating conditions for V_{DD} , f_{OSC} , and T_A unless otherwise specified.

Symbol	Parameter	Conditions	Min	Max	Unit
$V_{OL}^{1)}$	Output low level voltage for a standard I/O pin when 8 pins are sunk at same time (see Figure 83 and Figure 86)	$I_{IO}=+5mA$ $T_A \leq 85^\circ C$		1.3	V
		$T_A \geq 85^\circ C$		1.5	
	$I_{IO}=+2mA$ $T_A \leq 85^\circ C$		0.65		
		$T_A \geq 85^\circ C$		0.75	
Output low level voltage for a high sink I/O pin when 4 pins are sunk at same time (see Figure 84 and Figure 87)	$I_{IO}=+20mA$, $T_A \leq 85^\circ C$		1.5		
	$T_A \geq 85^\circ C$		1.7		
$V_{OH}^{2)}$	Output high level voltage for an I/O pin when 4 pins are sourced at same time (see Figure 85 and Figure 88)	$I_{IO}=-5mA$, $T_A \leq 85^\circ C$	$V_{DD}-1.6$		
		$T_A \geq 85^\circ C$	$V_{DD}-1.7$		
		$I_{IO}=-2mA$ $T_A \leq 85^\circ C$	$V_{DD}-0.8$		
		$T_A \geq 85^\circ C$	$V_{DD}-1.0$		

Figure 83. Typical V_{OL} at $V_{DD}=5V$ (standard)

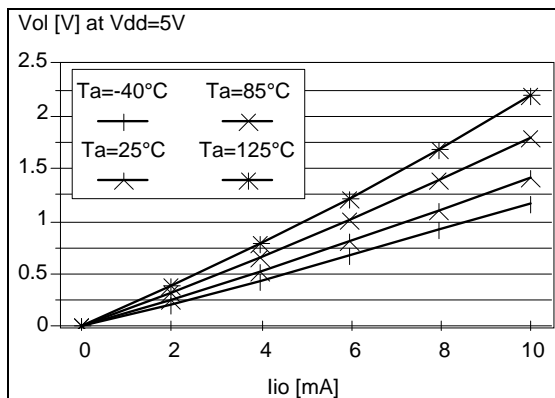

Figure 85. Typical V_{OH} at $V_{DD}=5V$

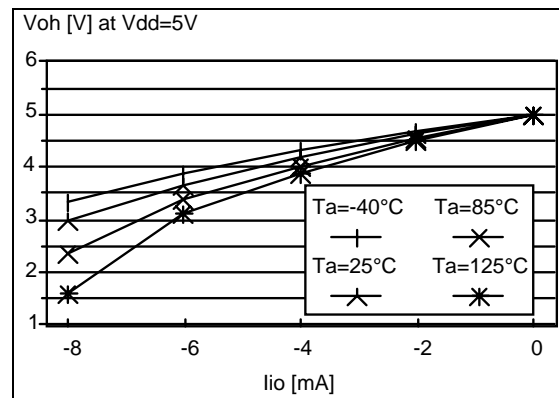
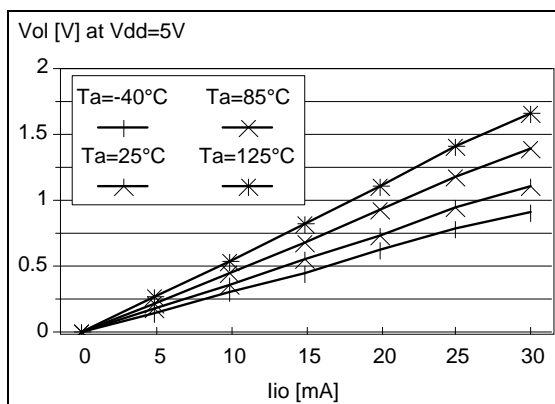

Figure 84. Typical V_{OL} at $V_{DD}=5V$ (high-sink)



Notes:

1. The I_{IO} current sunk must always respect the absolute maximum rating specified in Section 15.2.2 and the sum of I_{IO} (I/O ports and control pins) must not exceed I_{VSS} .
2. The I_{IO} current sourced must always respect the absolute maximum rating specified in Section 15.2.2 and the sum of I_{IO} (I/O ports and control pins) must not exceed I_{VDD} . True open drain I/O pins does not have V_{OH} .

I/O PORT PIN CHARACTERISTICS (Cont'd)

Figure 86. Typical V_{OL} vs. V_{DD} (standard I/Os)

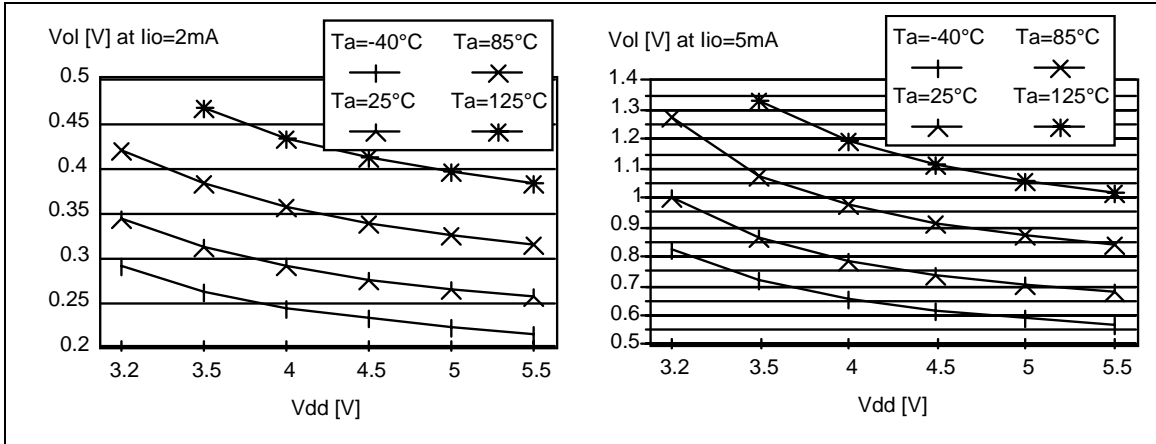

Figure 87. Typical V_{OL} vs. V_{DD} (high-sink I/Os)

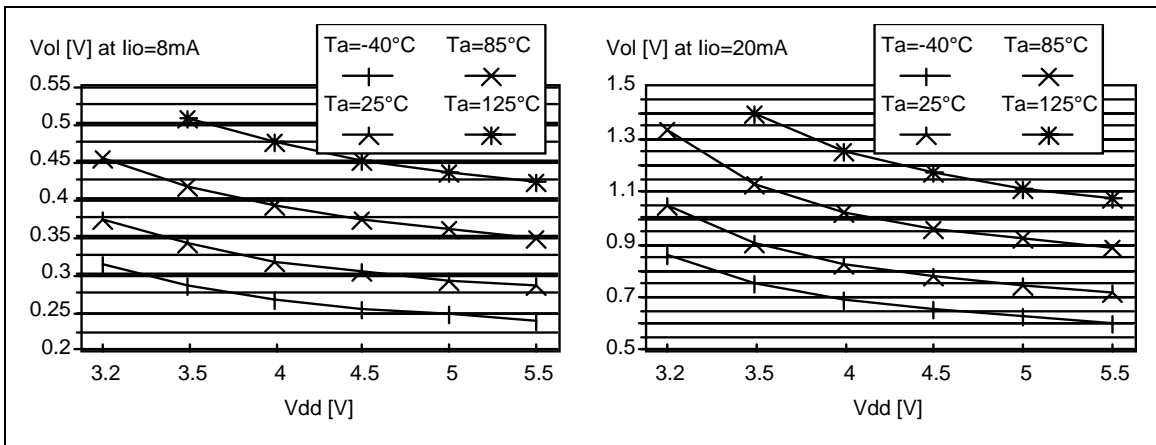
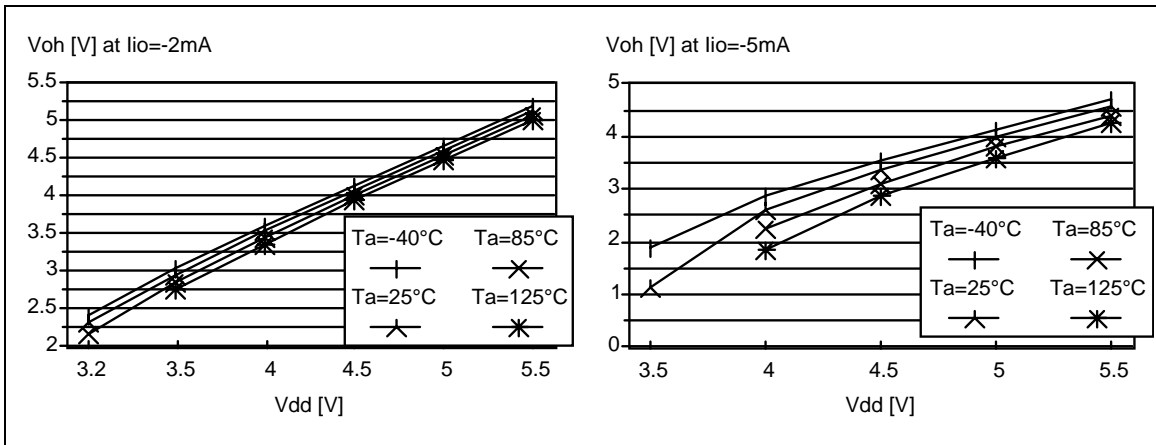

Figure 88. Typical V_{OH} vs. V_{DD}



15.9 CONTROL PIN CHARACTERISTICS

15.9.1 Asynchronous $\overline{\text{RESET}}$ Pin

Subject to general operating conditions for V_{DD} , f_{OSC} , and T_A unless otherwise specified.

Symbol	Parameter	Conditions	Min	Typ ¹⁾	Max	Unit	
V_{IL}	Input low level voltage ²⁾				$0.3 \times V_{DD}$	V	
V_{IH}	Input high level voltage ²⁾		$0.7 \times V_{DD}$				
V_{hys}	Schmitt trigger voltage hysteresis ³⁾			400		mV	
V_{OL}	Output low level voltage ⁴⁾ (see Figure 91, Figure 92)	$V_{DD}=5V$	$I_{IO}=-5mA$	0.68	0.95	V	
			$I_{IO}=+2mA$	0.28	0.45		
R_{ON}	Weak pull-up equivalent resistor ⁵⁾	$V_{IN}=V_{SS}$	$V_{DD}=5V$	20	40	60	k Ω
			$V_{DD}=3.4V$	80	100	120	
$t_{w(RSTL)out}$	Generated reset pulse duration	External pin or internal reset sources		6 30		$1/f_{SFOSC}$ μs	
$t_{h(RSTL)in}$	External reset pulse hold time ⁶⁾		20			μs	
$t_{g(RSTL)in}$	Filtered glitch duration ⁷⁾				100	ns	

Figure 89. Typical Application with $\overline{\text{RESET}}$ Pin⁸⁾

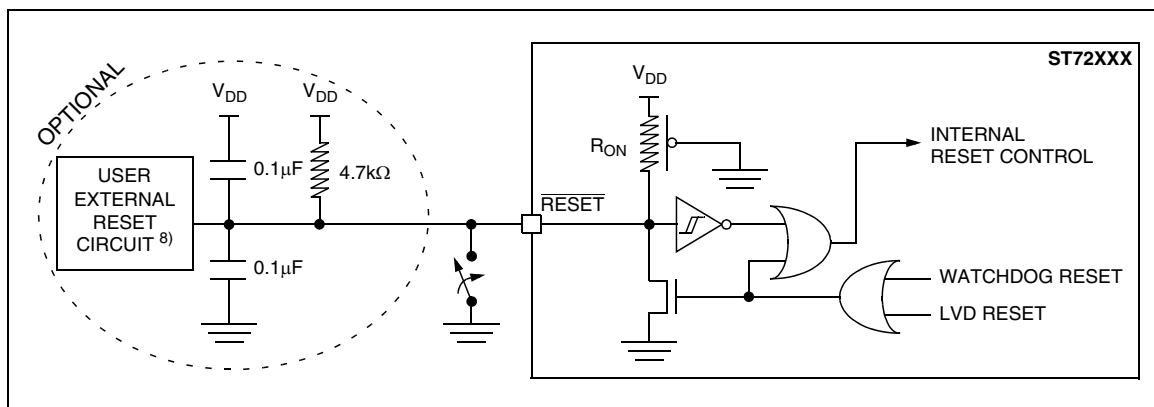

Notes:

- Unless otherwise specified, typical data is based on $T_A=25^\circ C$ and $V_{DD}=5V$.
- Data based on characterization results, not tested in production.
- Hysteresis voltage between Schmitt trigger switching levels. Based on characterization results, not tested.
- The I_{IO} current sunk must always respect the absolute maximum rating specified in Section 15.2.2 and the sum of I_{IO} (I/O ports and control pins) must not exceed I_{VSS} .
- The R_{ON} pull-up equivalent resistor is based on a resistive transistor (corresponding I_{ON} current characteristics described in Figure 90). This data is based on characterization results, not tested in production.
- To guarantee the reset of the device, a minimum pulse has to be applied to $\overline{\text{RESET}}$ pin. All short pulses applied on $\overline{\text{RESET}}$ pin with a duration below $t_{h(RSTL)in}$ can be ignored.
- The reset network (the resistor and two capacitors) protects the device against parasitic resets, especially in a noisy environments.
- The output of the external reset circuit must have an open-drain output to drive the ST7 reset pad. Otherwise the device can be damaged when the ST7 generates an internal reset (LVD or watchdog).

CONTROL PIN CHARACTERISTICS (Cont'd)

Figure 90. Typical I_{ON} vs. V_{DD} with $V_{IN}=V_{SS}$

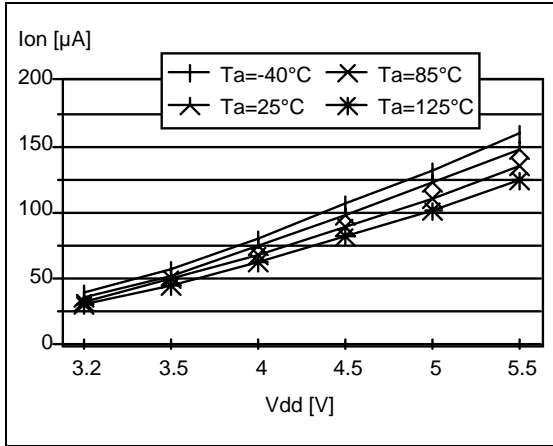

Figure 91. Typical V_{OL} at $V_{DD}=5V$ (RESET)

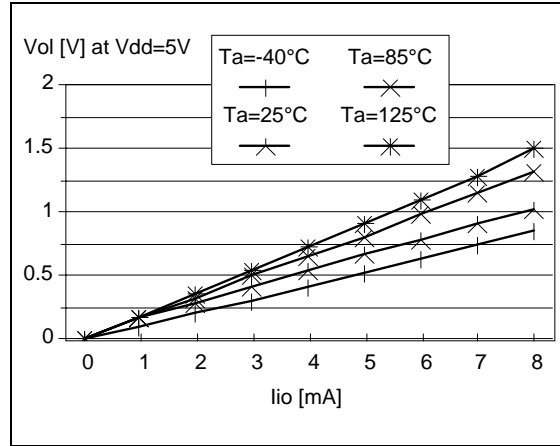
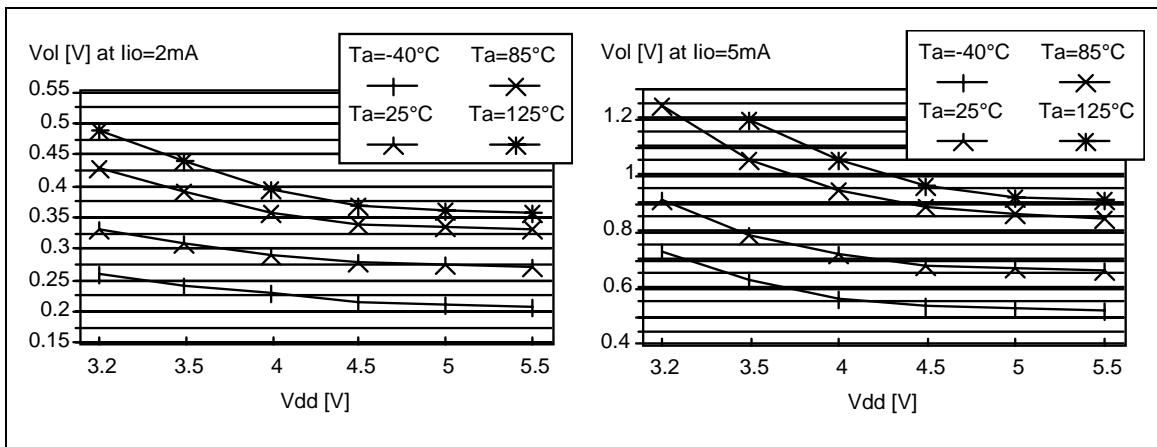

Figure 92. Typical V_{OL} vs. V_{DD} (RESET)



CONTROL PIN CHARACTERISTICS (Cont'd)

15.9.2 ISPSEL Pin

Subject to general operating conditions for V_{DD} , f_{OSC} , and T_A unless otherwise specified.

Symbol	Parameter	Conditions	Min	Max	Unit
V_{IL}	Input low level voltage ¹⁾		V_{SS}	0.2	V
V_{IH}	Input high level voltage ¹⁾		$V_{DD}-0.1$	12.6	V
I_L	Input leakage current	$V_{IN}=V_{SS}$		± 1	μA

Figure 93. Two Typical Applications with ISPSEL Pin ²⁾

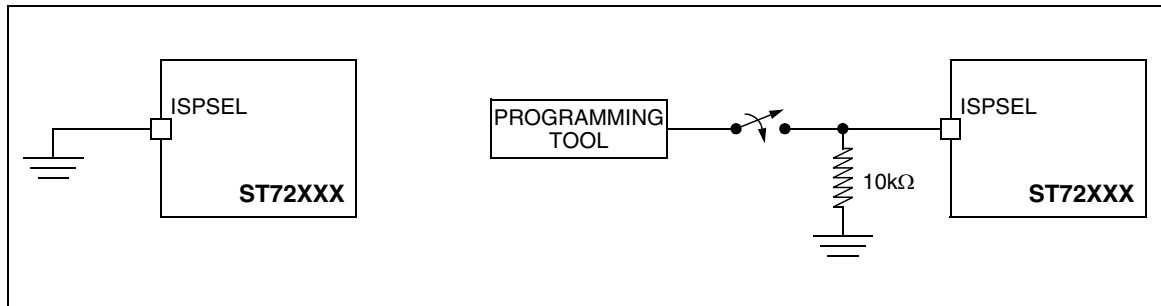

Notes:

1. Data based on design simulation and/or technology characteristics, not tested in production.
2. When the ISP Remote mode is not required by the application ISPSEL pin must be tied to V_{SS} .

15.10 TIMER PERIPHERAL CHARACTERISTICS

Subject to general operating conditions for V_{DD} , f_{OSC} , and T_A unless otherwise specified.

Refer to I/O port characteristics for more details on the input/output alternate function characteristics (output compare, input capture, external clock, PWM output...).

15.10.1 Watchdog Timer

Symbol	Parameter	Conditions	Min	Typ	Max	Unit
$t_{w(WDG)}$	Watchdog time-out duration		12288		786432	t_{CPU}
		$f_{CPU} = 8 \text{ MHz}$	1.54		98.3	ms

15.10.2 16-Bit Timer

Symbol	Parameter	Conditions	Min	Typ	Max	Unit
$t_{w(ICAP)in}$	Input capture pulse time		1			t_{CPU}
$t_{res(PWM)}$	PWM resolution time		2			t_{CPU}
		$f_{CPU} = 8 \text{ MHz}$	250			ns
f_{EXT}	Timer external clock frequency		0		$f_{CPU}/4$	MHz
f_{PWM}	PWM repetition rate		0		$f_{CPU}/4$	MHz
Res_{PWM}	PWM resolution				16	bit

15.11 COMMUNICATION INTERFACE CHARACTERISTICS

15.11.1 SPI - Serial Peripheral Interface

Subject to general operating conditions for V_{DD} , f_{OSC} , and T_A unless otherwise specified.

Refer to I/O port characteristics for more details on the input/output alternate function characteristics (\overline{SS} , SCK, MOSI, MISO).

Symbol	Parameter	Conditions	Min	Max	Unit
f_{SCK} $1/t_c(SCK)$	SPI clock frequency	Master $f_{CPU} = 8 \text{ MHz}$	$f_{CPU}/128$ 0.0625	$f_{CPU}/4$ 2	MHz
		Slave $f_{CPU} = 8 \text{ MHz}$	0	$f_{CPU}/2$ 4	
$t_{r(SCK)}$ $t_{f(SCK)}$	SPI clock rise and fall time		see I/O port pin description		
$t_{su}(\overline{SS})$	\overline{SS} setup time	Slave	120		ns
$t_{h}(\overline{SS})$	\overline{SS} hold time	Slave	120		
$t_w(SCKH)$ $t_w(SCKL)$	SCK high and low time	Master	100		
		Slave	90		
$t_{su}(MI)$ $t_{su}(SI)$	Data input setup time	Master	100		
		Slave	100		
$t_h(MI)$ $t_h(SI)$	Data input hold time	Master	100		
		Slave	100		
$t_a(SO)$	Data output access time	Slave	0	120	
$t_{dis}(SO)$	Data output disable time	Slave		240	
$t_v(SO)$	Data output valid time	Slave (after enable edge)		120	
$t_h(SO)$	Data output hold time		0		
$t_v(MO)$	Data output valid time	Master (before capture edge)	0.25		t_{CPU}
$t_h(MO)$	Data output hold time		0.25		

Figure 94. SPI Slave Timing Diagram with CPHA = 0³⁾

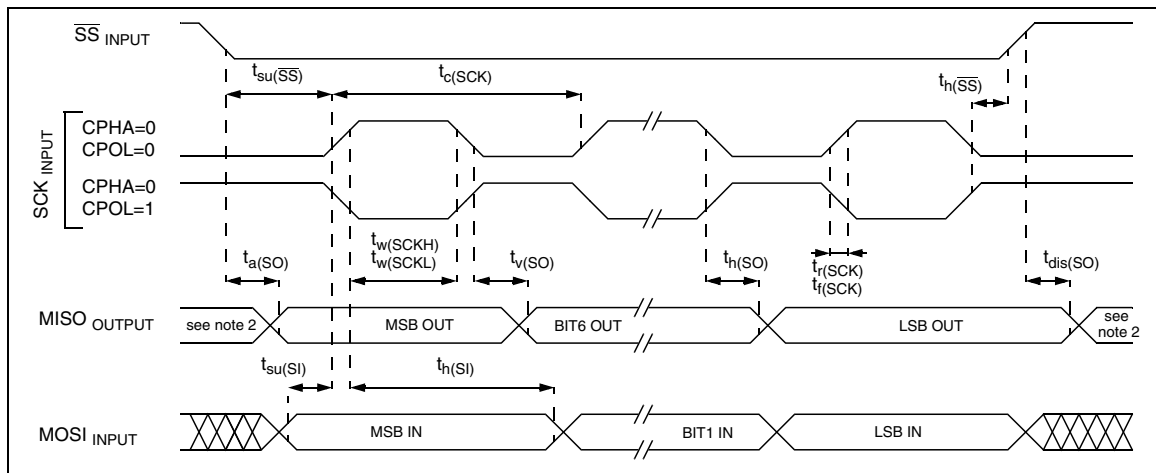

Notes:

1. Data based on design simulation and/or characterization results, not tested in production.
2. When no communication is on-going the data output line of the SPI (MOSI in master mode, MISO in slave mode) has its alternate function capability released. In this case, the pin status depends on the I/O port configuration.
3. Measurement points are done at CMOS levels: $0.3 \times V_{DD}$ and $0.7 \times V_{DD}$.

COMMUNICATION INTERFACE CHARACTERISTICS (Cont'd)

Figure 95. SPI Slave Timing Diagram with CPHA = 1¹⁾

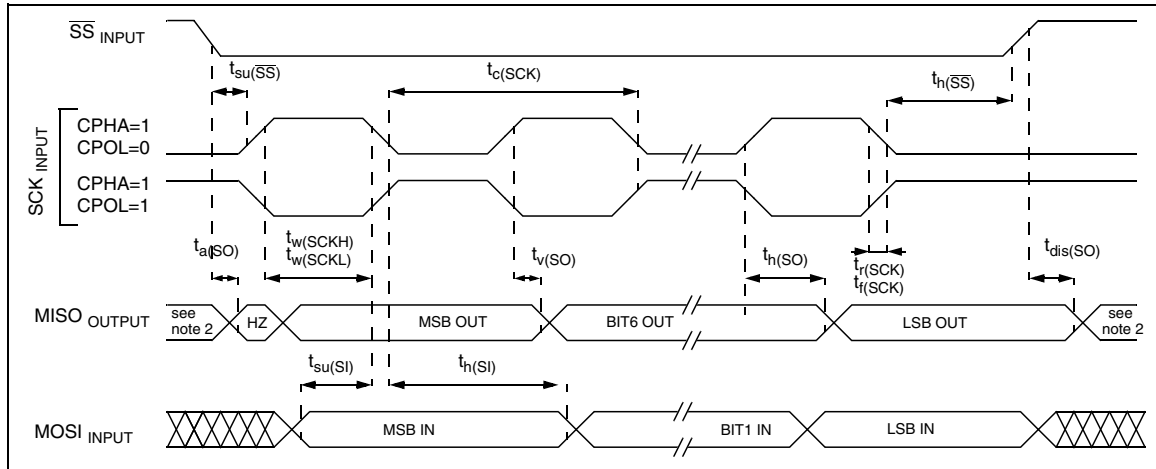
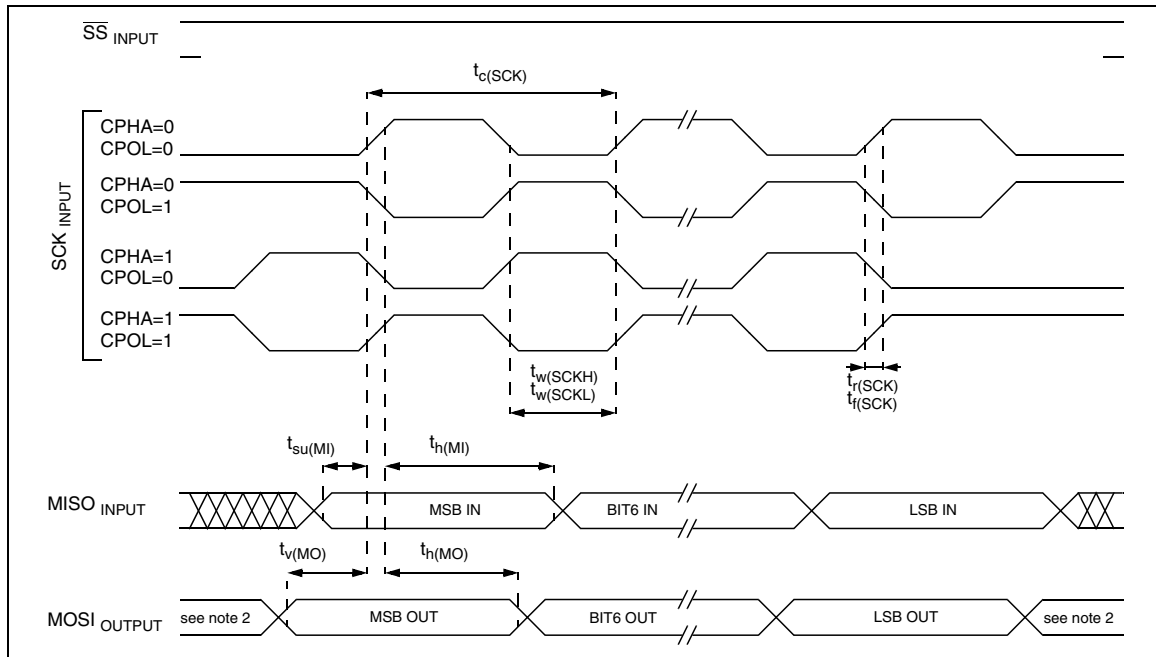

Figure 96. SPI Master Timing Diagram¹⁾



Notes:

1. Measurement points are done at CMOS levels: 0.3xV_{DD} and 0.7xV_{DD}.
2. When no communication is on-going the data output line of the SPI (MOSI in master mode, MISO in slave mode) has its alternate function capability released. In this case, the pin status depends of the I/O port configuration.

COMMUNICATIONS INTERFACE CHARACTERISTICS (Cont'd)

15.11.2 SCI - Serial Communications Interface

Subject to general operating condition for V_{DD} , f_{OSC} , and T_A unless otherwise specified.

Refer to I/O port characteristics for more details on the input/output alternate function characteristics (RDI and TDO).

Symbol	Parameter	Conditions			Standard	Baud Rate	Unit
		f_{CPU}	Accuracy vs. Standard	Prescaler			
f_{Tx} f_{Rx}	Communication frequency	8MHz	~0.16%	Conventional Mode TR (or RR)=64, PR=13	300	~300.48	Hz
				TR (or RR)=16, PR=13	1200	~1201.92	
				TR (or RR)= 8, PR=13	2400	~2403.84	
				TR (or RR)= 4, PR=13	4800	~4807.69	
				TR (or RR)= 2, PR=13	9600	~9615.38	
				TR (or RR)= 8, PR= 3	10400	~10416.67	
				TR (or RR)= 1, PR=13	19200	~19230.77	
				Extended Mode ETPR (or ERPR) = 13	38400	~38461.54	
			~0.79%	Extended Mode ETPR (or ERPR) = 35	14400	~14285.71	

15.12 8-BIT ADC CHARACTERISTICS

Subject to general operating conditions for V_{DD} , f_{OSC} , and T_A unless otherwise specified.

Symbol	Parameter	Conditions	Min	Typ ¹⁾	Max	Unit
f_{ADC}	ADC clock frequency				4	MHz
V_{AIN}	Conversion range voltage ²⁾		V_{SSA}		V_{DDA}	V
R_{AIN}	External input resistor				10^3 ³⁾	k Ω
C_{ADC}	Internal sample and hold capacitor			6		pF
t_{STAB}	Stabilization time after ADC enable	$f_{CPU}=8\text{MHz}$, $f_{ADC}=4\text{MHz}$	0 ⁴⁾			μs
t_{ADC}	Conversion time (Sample+Hold)		3			
	- Sample capacitor loading time - Hold conversion time		4 8			$1/f_{ADC}$

Figure 97. Typical Application with ADC

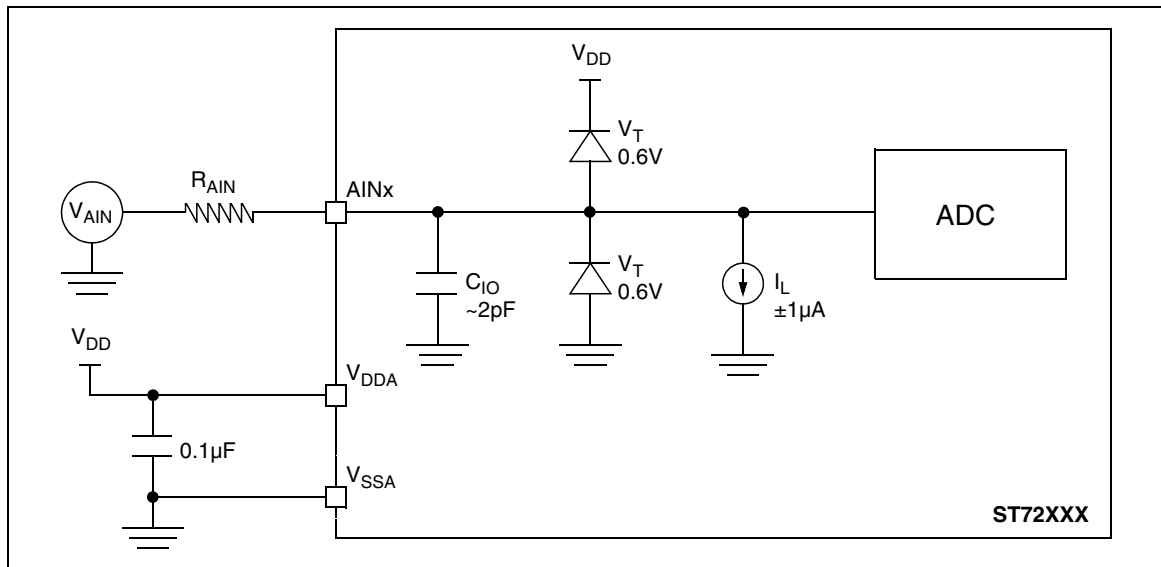

Notes:

1. Unless otherwise specified, typical data is based on $T_A=25^\circ\text{C}$ and $V_{DD}-V_{SS}=5\text{V}$. They are given only as design guidelines and are not tested.
2. When V_{DDA} and V_{SSA} pins are not available on the pinout, the ADC refer to V_{DD} and V_{SS} .
3. Any added external serial resistor will downgrade the ADC accuracy (especially for resistance greater than 10k Ω). Data based on characterization results, not tested in production.
4. The stabilization time of the AD converter is masked by the first t_{LOAD} . The first conversion after the enable is then always valid.

8-BIT ADC CHARACTERISTICS (Cont'd)

ADC Accuracy

Symbol	Parameter	V _{DD} =5V, ²⁾ f _{CPU} =1MHz		V _{DD} =5.0V, ³⁾ f _{CPU} =8MHz		V _{DD} =3.3V, ³⁾ f _{CPU} =8MHz		Unit
		Typ.	Max	Typ.	Max	Typ.	Max	
E _T	Total unadjusted error ¹⁾		2.0		2.0		2.0	LSB
E _O	Offset error ¹⁾		1.5		1.5		1.5	
E _G	Gain Error ¹⁾		1.5		1.5		1.5	
E _D	Differential linearity error ¹⁾		1.5		1.5		1.5	
E _L	Integral linearity error ¹⁾		1.5		1.5		1.5	

Figure 98. ADC Accuracy Characteristics

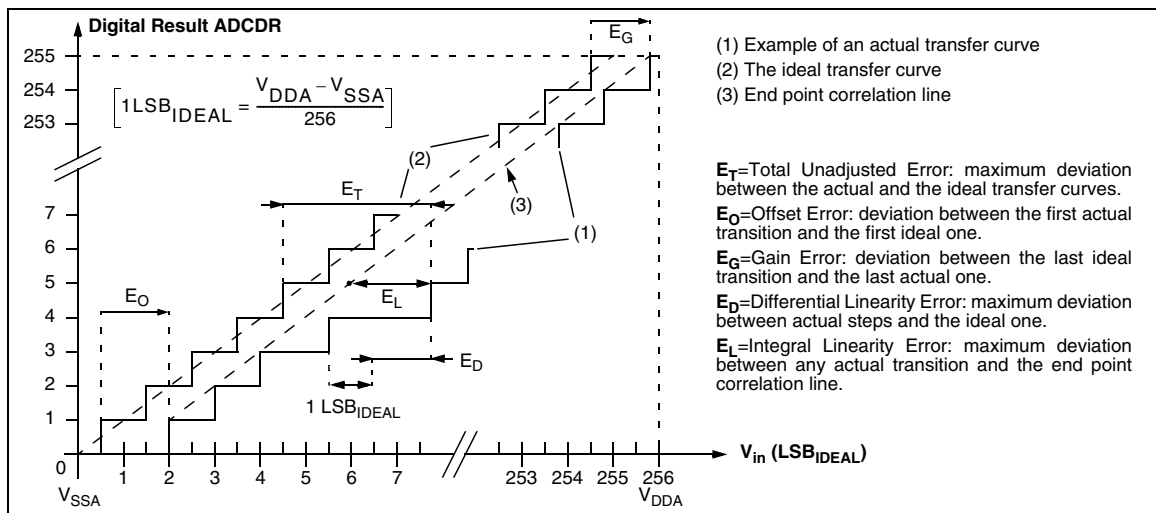

Notes:

- ADC Accuracy vs. Negative Injection Current:
 For I_{INJ.} = 0.8mA, the typical leakage induced inside the die is 1.6µA and the effect on the ADC accuracy is a loss of 1 LSB for each 10KΩ increase of the external analog source impedance. This effect on the ADC accuracy has been observed under worst-case conditions for injection:
 - negative injection
 - injection to an Input with analog capability, adjacent to the enabled Analog Input
 - at 5V V_{DD} supply, and worst case temperature.
- Data based on characterization results with T_A = 25°C.
- Data based on characterization results over the whole temperature range.

16 PACKAGE CHARACTERISTICS

16.1 PACKAGE MECHANICAL DATA

Figure 99. 64-Pin Thin Quad Flat Package (14x14)

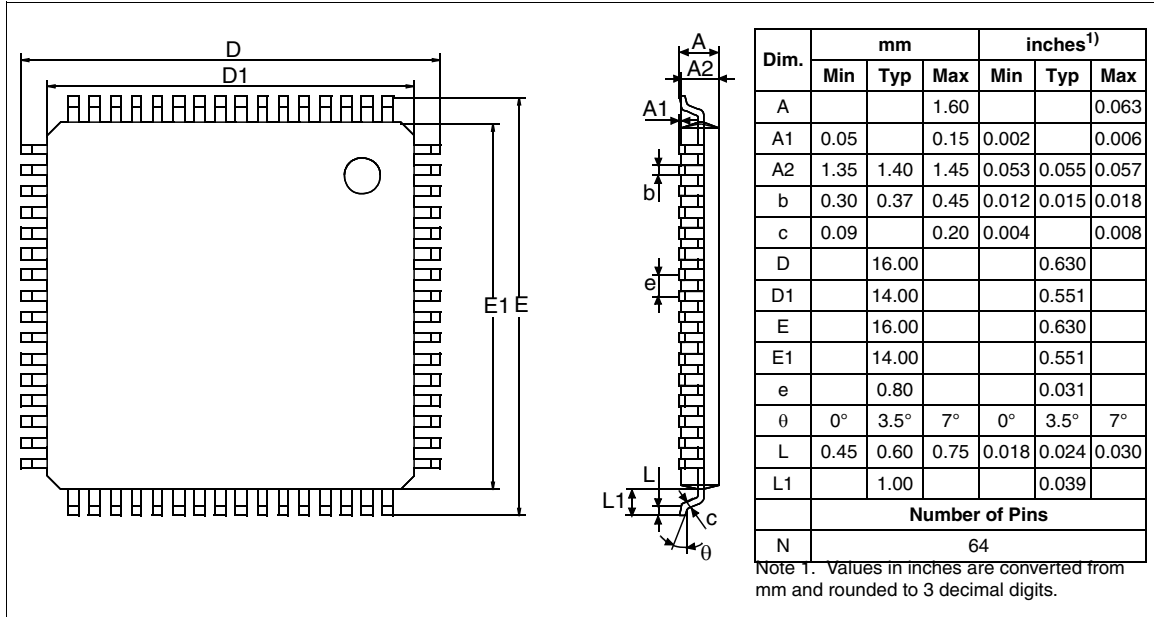
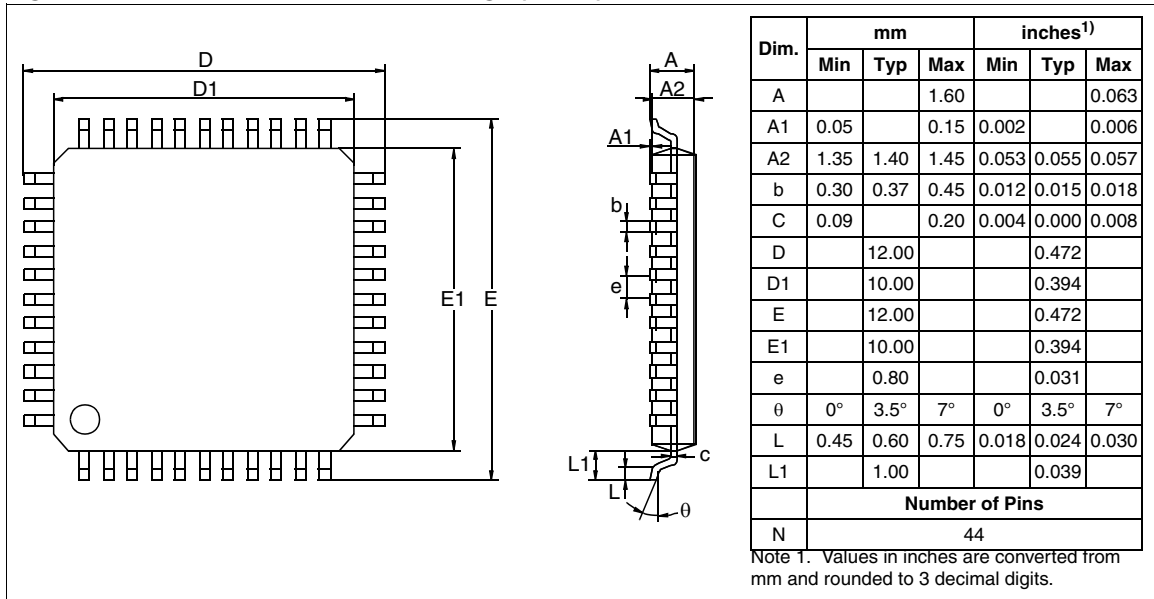

Figure 100. 44-Pin Thin Quad Flat Package (10x10)



PACKAGE CHARACTERISTICS (Cont'd)

16.2 THERMAL CHARACTERISTICS

Symbol	Ratings	Value	Unit
R_{thJA}	Package thermal resistance (junction to ambient)		
	TQFP64	60	°C/W
	TQFP44	52	
P_D	Power dissipation ¹⁾	500	mW
T_{Jmax}	Maximum junction temperature ²⁾	150	°C

Notes:

1. The power dissipation is obtained from the formula $P_D = P_{INT} + P_{PORT}$ where P_{INT} is the chip internal power ($I_{DD} \times V_{DD}$) and P_{PORT} is the port power dissipation determined by the user.

2. The average chip-junction temperature can be obtained from the formula $T_J = T_A + P_D \times R_{thJA}$.

16.3 ECOPACK®

In order to meet environmental requirements, ST offers these devices in ECOPACK® packages. These packages have a lead-free second level interconnect. The category of second level interconnect is marked on the package and on the inner box label, in compliance with JEDEC Standard

JESD97. The maximum ratings related to soldering conditions are also marked on the inner box label.

ECOPACK is an ST trademark. ECOPACK® specifications are available at www.st.com.

17 DEVICE CONFIGURATION AND ORDERING INFORMATION

17.1 INTRODUCTION

Each device is available for production in user programmable versions (Flash) as well as in factory coded versions (ROM). EEPROM data memory and Flash devices are shipped to customers with a default content (FFh), while ROM factory coded parts contain the code supplied by the customer. This implies that Flash devices have to be configured by the customer using the Option Bytes while the ROM devices are factory-configured.

17.2 OPTION BYTES

The two option bytes allow the hardware configuration of the microcontroller to be selected.

The option bytes have no address in the memory map and can be accessed only in programming mode (for example using a standard ST7 programming tool). The default content of the Flash is fixed to FFh.

In masked ROM devices, the option bytes are fixed in hardware by the ROM code (see option list).

17.2.1 User Option Byte 0

Bit 7:2 = **Reserved**, must always be 1.

Bit 1 = **64/44 Package Configuration**.

This option bit allows to configure the device according to the package.

0: 44-pin packages
1: 64-pin packages

Bit 0 = **FMP Full memory protection**.

This option bit enables or disables external access to the internal program memory (readout protection). Clearing this bit causes the erasing (by overwriting with the currently latched values) of the whole memory (not including the option bytes).

0: Program memory not readout protected
1: Program memory readout protected

Note: The data EEPROM is not protected by this bit in Flash devices. In ROM devices, a protection can be selected in the Option List (see [page 145](#)).

17.2.2 User Option Byte 1

Bit 7 = **CSS Clock Security System disable**

This option bit enables or disables the CSS features.

0: CSS enabled
1: CSS disabled

Bit 6:4 = **OSC[2:0] Oscillator selection**

These three option bits can be used to select the main oscillator as shown in [Table 25](#).

Bit 3:2 = **LVD[1:0] Low voltage detection selection**

These option bits enable the LVD block with a selected threshold as shown in [Table 26](#).

Bit 1 = **WDG HALT Watchdog Reset on Halt mode**

This option bit determines if a RESET is generated when entering Halt mode while the Watchdog is active.

0: No Reset generation when entering Halt mode
1: Reset generation when entering Halt mode

Bit 0 = **WDG SW Hardware or software watchdog**

This option bit selects the watchdog type.

0: Hardware (watchdog always enabled)
1: Software (watchdog to be enabled by software)

Table 25. Main Oscillator Configuration

Selected Oscillator	OSC2	OSC1	OSC0
External Clock (Stand-by)	1	1	1
~4 MHz Internal RC	1	1	0
1~14 MHz External RC	1	0	X
Low Power Resonator (LP)	0	1	1
Medium Power Resonator (MP)	0	1	0
Medium Speed Resonator (MS)	0	0	1
High Speed Resonator (HS)	0	0	0

Table 26. LVD Threshold Configuration

Configuration	LVD1	LVD0
LVD Off	1	1
Highest Voltage Threshold (~4.50V)	1	0
Medium Voltage Threshold (~4.05V)	0	1
Lowest Voltage Threshold (~3.45V)	0	0

	USER OPTION BYTE 0								USER OPTION BYTE 1								
	7							0	7				0				
	Reserved							64/44	FMP	CSS	OSC 2	OSC 1	OSC 0	LVD1	LVD0	WDG HALT	WDG SW
Default Value	1	1	1	1	1	1	1	X	0	1	1	1	0	1	1	1	1

DEVICE CONFIGURATION AND ORDERING INFORMATION (Cont'd)

17.3 TRANSFER OF CUSTOMER CODE

Customer code is made up of the ROM contents and the list of the selected options (if any). The ROM contents are to be sent on diskette, or by electronic means, with the hexadecimal file in .S19 format generated by the development tool. All unused bytes must be set to FFh.

The selected options are communicated to STMicroelectronics using the correctly completed OPTION LIST appended.

The STMicroelectronics Sales Organization will be pleased to provide detailed information on contractual points.

Figure 101. ROM Factory Coded Device Types

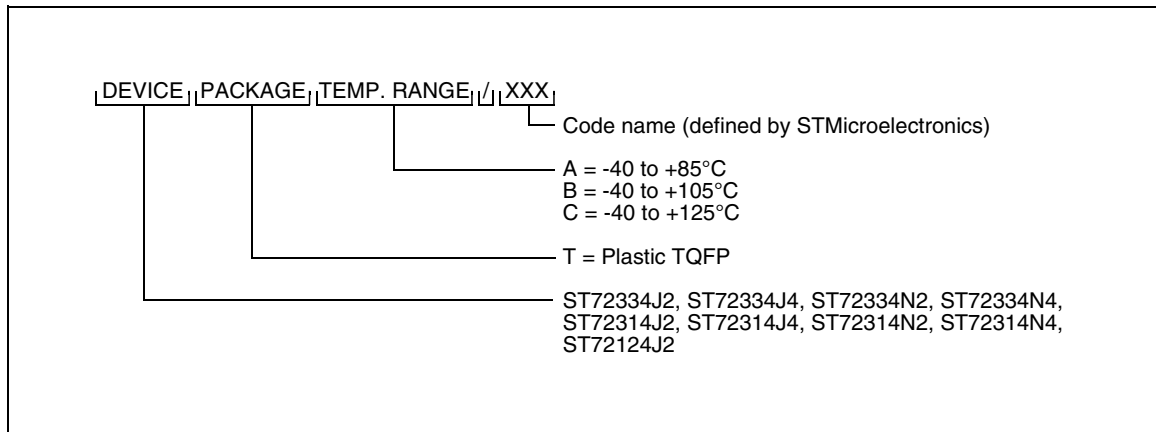
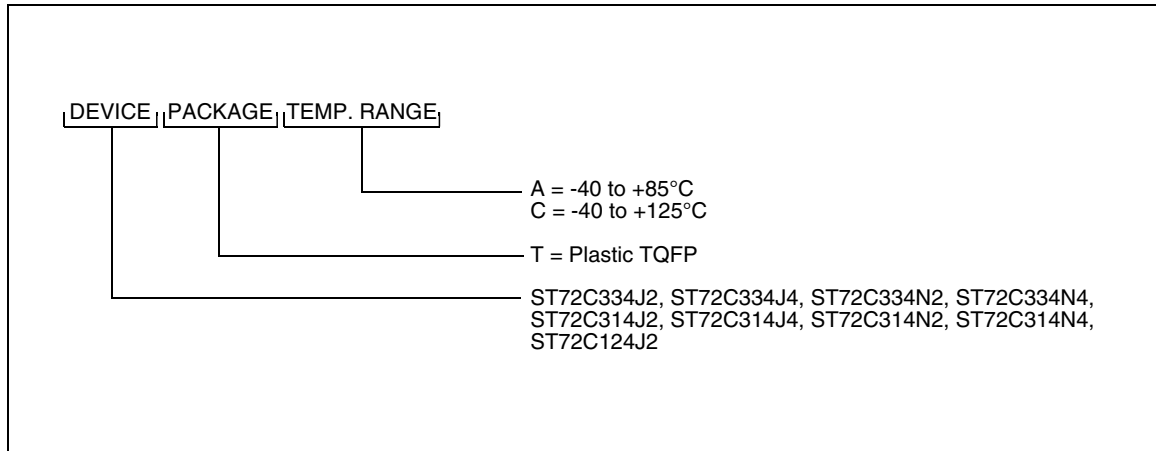

Figure 102. Flash User Programmable Device Types



MICROCONTROLLER OPTION LIST			
Customer:		
Address:		
Contact:		
Phone No:		
Reference/ROM code*:		
*The ROM or FASTROM code name is assigned by STMicroelectronics.			
ROM or FASTROM code must be sent in .S19 format. .Hex extension cannot be processed.			
STMicroelectronics references			
ROM Type/Memory Size/Package (check only one option):			
ROM DEVICE:	8K	16K	
TQFP44:	<input type="checkbox"/> ST72124J2T	<input type="checkbox"/> ST72314J4T	
	<input type="checkbox"/> ST72314J2T	<input type="checkbox"/> ST72334J4T	
	<input type="checkbox"/> ST72334J2T	<input type="checkbox"/> ST72314N4T	
TQFP64:	<input type="checkbox"/> ST72314N2T	<input type="checkbox"/> ST72334N4T	
	<input type="checkbox"/> ST72334N2T		
FASTROM DEVICE:	8K	16K	
TQFP44:	<input type="checkbox"/> ST72P124J2T	<input type="checkbox"/> ST72P314J4T	
	<input type="checkbox"/> ST72P314J2T	<input type="checkbox"/> ST72P334J4T	
	<input type="checkbox"/> ST72P334J2T	<input type="checkbox"/> ST72P314N4T	
TQFP64:	<input type="checkbox"/> ST72P314N2T	<input type="checkbox"/> ST72P334N4T	
	<input type="checkbox"/> ST72P334N2T		
Conditioning:	<input type="checkbox"/> Tape and Reel	<input type="checkbox"/> Tray	
Marking:	<input type="checkbox"/> Standard marking	<input type="checkbox"/> Special marking (ROM only):	
		TQFP (10 char. max) :	-----
Authorized characters are letters, digits, '-', '+', '/' and spaces only.			
Please consult your local STMicroelectronics sales office for other marking details if required.			
Temperature Range:	<input type="checkbox"/> -40°C to +85°C	<input type="checkbox"/> -40°C to +105°C	<input type="checkbox"/> -40°C to +125°C
Clock Source Selection:			
Resonator:	<input type="checkbox"/> LP: Low power resonator (1 to 2 MHz) <input type="checkbox"/> MP: Medium power resonator (2 to 4 MHz) <input type="checkbox"/> MS: Medium speed resonator (4 to 8 MHz) <input type="checkbox"/> HS: High speed resonator (8 to 16 MHz)		
RC Network:	<input type="checkbox"/> Internal	<input type="checkbox"/> External	
External Clock:	<input type="checkbox"/>		
Clock Security System:	<input type="checkbox"/> Disabled	<input type="checkbox"/> Enabled	
LVD Reset:	<input type="checkbox"/> Disabled	<input type="checkbox"/> Enabled:	<input type="checkbox"/> Highest threshold <input type="checkbox"/> Medium threshold <input type="checkbox"/> Lowest threshold
Watchdog Selection:	<input type="checkbox"/> Software Activation	<input type="checkbox"/> Hardware Activation	
Watchdog Reset on Halt:	<input type="checkbox"/> Reset	<input type="checkbox"/> No reset	
Program Readout Protection:	<input type="checkbox"/> Disabled	<input type="checkbox"/> Enabled	
Data EEPROM Readout Protection*:	<input type="checkbox"/> Disabled	<input type="checkbox"/> Enabled	
*available on ST72334 only			
Comments:		
Supply Operating Range in the application:		
Notes:		
Date:		
Signature:		

17.4 DEVELOPMENT TOOLS

STMicroelectronics offers a range of hardware and software development tools for the ST7 micro-controller family. Full details of tools available for the ST7 from third party manufacturers can be obtained from the STMicroelectronics Internet site www.st.com.

Tools from these manufacturers include C compilers, emulators and gang programmers.

STMicroelectronics Tools

Three types of development tool are offered by ST, all of them connect to a PC via a parallel (LPT) port: see [Table 27](#) and [Table 28](#) for more details.

Table 27. STMicroelectronics Tool Features

Tool	In-Circuit Emulation	Programming Capability ¹⁾	Software Included
ST7 Development Kit	Yes (same features as HDS2 emulator but without logic analyzer)	Yes (DIP packages only) ²⁾	ST7 CD ROM with: – ST7 Assembly toolchain – STVD7 and WGDB7 powerful Source Level Debugger for Win 3.1, Win 95 and NT – C compiler demo versions
ST7 HDS2 Emulator	Yes, powerful emulation features including trace/ logic analyzer	No	– ST Realizer for Win 3.1 and Win 95 – Windows Programming Tools for Win 3.1, Win 95 and NT
ST7 Programming Board	No	Yes	

Notes:

1. In-Situ Programming (ISP) interface for Flash devices.
2. Tool equipped with a DIP socket only; an adapter may be required to program devices in TQFP packages.

Table 28. Dedicated STMicroelectronics Development Tools

Supported Products	ST7 Development Kit	ST7 HDS2 Emulator	ST7 Programming Board
ST72(C)334J2, ST72(C)334J4, ST72(C)334N2, ST72(C)334N4, ST72(C)314J2, ST72(C)314J4, ST72(C)314N2, ST72(C)314N4, ST72(C)124J2	ST7MDT2-DVP2	ST7MDT2-EMU2B	ST7MDT2-EPB2/EU ST7MDT2-EPB2/US ST7MDT2-EPB2/UK

DEVELOPMENT TOOLS (Cont'd)

17.4.1 Suggested List of Socket Types

Table 29. Suggested List of TQFP64 Socket Types

Package / Probe	Adaptor / Socket Reference		Socket type
TQFP64	ENPLAS	OTQ-64-0.8-02	Open Top
	YAMAICHI	IC51-0644-1240.KS-14584	Clamshell
EMU PROBE	YAMAICHI	IC149-064-008-S5	SMC

Table 30. Suggested List of TQFP44 Socket Types

Package / Probe	Adaptor / Socket Reference		Socket type
TQFP44	ENPLAS	OTQ-44-0.8-04	Open Top
	YAMAICHI	IC51-0444-467-KS-11787	Clamshell
TQFP44 EMU PROBE	YAMAICHI	IC149-044-*52-S5	SMC

17.5 ST7 APPLICATION NOTES

All relevant ST7 application notes can be found on www.st.com.

18 IMPORTANT NOTES

18.1 SCI BAUD RATE REGISTERS

Caution: The SCI baud rate register (SCIBRR) MUST NOT be written to (changed or refreshed) while the transmitter or the receiver is enabled.

19 SUMMARY OF CHANGES

Description of the changes between the current release of the specification and the previous one.

Date	Revision	Main changes
17-Oct-2007	1	<p>Initial release of the ST72334xx-Auto, ST72314xx-Auto, ST72124Jx-Auto datasheet</p> <p>This datasheet was created from the ST72334J/N, ST72314J/N, ST72124J datasheet, revision 2.5 dated April 2003, with the following changes:</p> <p>Changed document title and description on page 1</p> <p>Removed PSDIP package outlines from page 1</p> <p>“Device Summary” on page 1:</p> <ul style="list-style-type: none"> - modified to include only automotive devices - replaced ‘ROM’ with ‘Flash/ROM’ as program memory for ST72124J2-Auto device - added operating temperature range specific to ROM devices <p>Section 1 "PREAMBLE: ST72C334-Auto VERSUS ST72E331 SPECIFICATION" on page 7:</p> <p>Replaced ST72C334 with ST72C334-Auto</p> <p>Section 2 "INTRODUCTION" on page 8: Added -Auto extension to ST72xxxJ/N numbers</p> <p>Section 3 "PIN DESCRIPTION" on page 9: Removed Figure "56-Pin SDIP Package Pinout"</p> <p>Figure 3.44-Pin TQFP Package Pinout (J versions): Removed SDIP package pinout</p> <p>Table 1, “Device Pin Description,” on page 11: Removed SDIP device pin number columns</p> <p>Section 8 "SUPPLY, RESET AND CLOCK MANAGEMENT" on page 26: Added -Auto extension to ST72xxxJ/N numbers in first paragraph</p> <p>Modified description of external and internal RC in “MULTI-OSCILLATOR (MO)” on page 30</p> <p>Section 13.1.3 "Functional Description" on page 50: Replaced 500ns with 30µs at end of second paragraph to be in line with spec given in Section 15.9.1 "Asynchronous RESET Pin" on page 132</p> <p>Section 14.1.4 "Indexed (No Offset, Short, Long)" on page 103: Replaced “The indirect addressing mode” with “The indexed addressing mode” in second paragraph</p> <p>Section 15.3.1 "General Operating Conditions" on page 111: Modified ambient temperature range conditions to include only automotive device suffix versions</p> <p>Figure 95.SPI Slave Timing Diagram with CPHA = 1 1): Replaced CPHA=0 with CPHA=1 for SCK_{INPUT}</p> <p>Section 16.1 "PACKAGE MECHANICAL DATA" on page 141:</p> <ul style="list-style-type: none"> - removed Figure “56-Pin Plastic Dual In-Line Package, Shrink 600-mil Width” - removed Figure “42-Pin Plastic Dual In-Line Package, Shrink 600-mil Width” - added Section 16.3 "ECOPACK®" on page 142 - removed Section "SOLDERING AND GLUEABILITY INFORMATION" <p>Section 16.2 "THERMAL CHARACTERISTICS" on page 142: Removed SDIP packages and associated values from package thermal resistance ratings</p> <p>Section 17.2.1 "User Option Byte 0" on page 143: Replaced 56/42-pin package configurations with 64/44-pin package configurations</p> <p>Figure 101.ROM Factory Coded Device Types: Modified to include only automotive devices</p> <p>Figure 102.Flash User Programmable Device Types:</p> <ul style="list-style-type: none"> - modified to include only automotive devices - removed B temperature version <p>“MICROCONTROLLER OPTION LIST” on page 145: Removed SDIP devices</p> <p>Section 17.4 "DEVELOPMENT TOOLS" on page 146: Replaced ‘http/mcu.st.com’ with ‘www.st.com’ at end of first paragraph</p> <p>Table 27, “STMicroelectronics Tool Features,” on page 146:</p> <ul style="list-style-type: none"> - changed programming capability from ‘Yes (all packages)’ to ‘Yes’ for ST7 Programming Board - added footnote 2 <p>Section 17.5 "ST7 APPLICATION NOTES" on page 147: Removed Table “ST7 Application Notes”</p> <p>Updated disclaimer on last page to include a mention about the use of ST products in automotive applications</p>

Please Read Carefully:

Information in this document is provided solely in connection with ST products. STMicroelectronics NV and its subsidiaries ("ST") reserve the right to make changes, corrections, modifications or improvements, to this document, and the products and services described herein at any time, without notice.

All ST products are sold pursuant to ST's terms and conditions of sale.

Purchasers are solely responsible for the choice, selection and use of the ST products and services described herein, and ST assumes no liability whatsoever relating to the choice, selection or use of the ST products and services described herein.

No license, express or implied, by estoppel or otherwise, to any intellectual property rights is granted under this document. If any part of this document refers to any third party products or services it shall not be deemed a license grant by ST for the use of such third party products or services, or any intellectual property contained therein or considered as a warranty covering the use in any manner whatsoever of such third party products or services or any intellectual property contained therein.

UNLESS OTHERWISE SET FORTH IN ST'S TERMS AND CONDITIONS OF SALE ST DISCLAIMS ANY EXPRESS OR IMPLIED WARRANTY WITH RESPECT TO THE USE AND/OR SALE OF ST PRODUCTS INCLUDING WITHOUT LIMITATION IMPLIED WARRANTIES OF MERCHANTABILITY, FITNESS FOR A PARTICULAR PURPOSE (AND THEIR EQUIVALENTS UNDER THE LAWS OF ANY JURISDICTION), OR INFRINGEMENT OF ANY PATENT, COPYRIGHT OR OTHER INTELLECTUAL PROPERTY RIGHT.

UNLESS EXPRESSLY APPROVED IN WRITING BY AN AUTHORIZED ST REPRESENTATIVE, ST PRODUCTS ARE NOT RECOMMENDED, AUTHORIZED OR WARRANTED FOR USE IN MILITARY, AIR CRAFT, SPACE, LIFE SAVING, OR LIFE SUSTAINING APPLICATIONS, NOR IN PRODUCTS OR SYSTEMS WHERE FAILURE OR MALFUNCTION MAY RESULT IN PERSONAL INJURY, DEATH, OR SEVERE PROPERTY OR ENVIRONMENTAL DAMAGE. ST PRODUCTS WHICH ARE NOT SPECIFIED AS "AUTOMOTIVE GRADE" MAY ONLY BE USED IN AUTOMOTIVE APPLICATIONS AT USER'S OWN RISK.

Resale of ST products with provisions different from the statements and/or technical features set forth in this document shall immediately void any warranty granted by ST for the ST product or service described herein and shall not create or extend in any manner whatsoever, any liability of ST.

ST and the ST logo are trademarks or registered trademarks of ST in various countries.

Information in this document supersedes and replaces all information previously supplied.

The ST logo is a registered trademark of STMicroelectronics. All other names are the property of their respective owners.

© 2007 STMicroelectronics - All rights reserved

STMicroelectronics group of companies

Australia - Belgium - Brazil - Canada - China - Czech Republic - Finland - France - Germany - Hong Kong - India - Israel - Italy - Japan - Malaysia - Malta - Morocco - Singapore - Spain - Sweden - Switzerland - United Kingdom - United States of America

www.st.com