



MOTOROLA

*Microprocessors and Memory
Technologies Group*

MC68LC302

Low Power Integrated Multiprotocol Processor Reference Manual

Motorola reserves the right to make changes without further notice to any products herein. Motorola makes no warranty, representation or guarantee regarding the suitability of its products for any particular purpose, nor does Motorola assume any liability arising out of the application or use of any product or circuit, and specifically disclaims any and all liability, including without limitation consequential or incidental damages. "Typical" parameters can and do vary in different applications. All operating parameters, including "Typicals" must be validated for each customer application by customer's technical experts. Motorola does not convey any license under its patent rights nor the rights of others. Motorola products are not designed, intended, or authorized for use as components in systems intended for surgical implant into the body, or other applications intended to support or sustain life, or for any other application in which the failure of the Motorola product could create a situation where personal injury or death may occur. Should Buyer purchase or use Motorola products for any such unintended or unauthorized application, Buyer shall indemnify and hold Motorola and its officers, employees, subsidiaries, affiliates, and distributors harmless against all claims, costs, damages, and expenses, and reasonable attorney fees arising out of, directly or indirectly, any claim of personal injury or death associated with such unintended or unauthorized use, even if such claim alleges that Motorola was negligent regarding the design or manufacture of the part. Motorola and  are registered trademarks of Motorola, Inc. Motorola, Inc. is an Equal Opportunity/Affirmative Action Employer.

Literature Distribution Centers:

USA/EUROPE: Motorola Literature Distribution; P.O. Box 20912, Arizona 85036.

JAPAN: Nippon Motorola Ltd.; 4-32-1, Nishi-Gotanda, Shinagawa-ku, Tokyo 141 Japan.

ASIA-PACIFIC: Motorola Semiconductors H.K. Ltd.; Silicon Harbour Center, No. 2 Dai King Street, Tai Po Industrial Estate,

PREFACE

The complete documentation package for the MC68LC302 consists of the MC68LC302RM/AD, *MC68LC302 Low Power Integrated Multiprotocol Processor Reference Manual*, M68000PM/AD, *MC68000 Family Programmer's Reference Manual*, MC68302UM/AD, *MC68302 Integrated Multiprotocol Processor User's Manual*, and the MC68LC302/D, *MC68LC302 Low Power Integrated Multiprotocol Processor Product Brief*.

The *MC68LC302 Low Power Integrated Multiprotocol Processor Reference Manual* describes the programming, capabilities, registers, and operation of the MC68LC302 that differ from the original MC68302; the *MC68000 Family Programmer's Reference Manual* provides instruction details for the MC68LC302; and the *MC68LC302 Low Power Integrated Multiprotocol Processor Product Brief* provides a brief description of the MC68LC302 capabilities.

The *MC68302 Integrated Multiprotocol Processor User's Manual* is required, since the *MC68LC302 Low Power Integrated Multiprotocol Processor Reference Manual* only describes the new features of the MC68LC302.

This user's manual is organized as follows:

- Section 1 Introduction
- Section 2 Configuration, Clocking, Low Power Modes, and Internal Memory Map
- Section 3 System Integration Block (SIB)
- Section 4 Communications Processor (CP)
- Section 5 Signal Description
- Section 6 Electrical Characteristics
- Section 7 Mechanical Data And Ordering Information

ELECTRONIC SUPPORT:

The Technical Support BBS, known as AESOP (Application Engineering Support Through On-Line Productivity), can be reach by modem or the internet. AESOP provides commonly asked application questions, latest device errata, device specs, software code, and many other useful support functions.

Modem: Call 1-800-843-3451 (outside US or Canada 512-891-3650) on a modem that runs at 14,400 bps or slower. Set your software to N/8/1/F emulating a vt100.

Internet: This access is provided by telneting to pirs.aus.sps.mot.com [129.38.233.1] or through the World Wide Web at <http://pirs.aus.sps.mot.com>.

— Sales Offices —

For questions or comments pertaining to technical information, questions, and applications, please contact one of the following sales offices nearest you.

UNITED STATES

ALABAMA , Huntsville	(205) 464-6800	MASSACHUSETTS , Marlborough	(508) 481-8100
ARIZONA , Tempe	(602) 897-5056	MASSACHUSETTS , Woburn	(617) 932-9700
CALIFORNIA , Agoura Hills	(818) 706-1929	MICHIGAN , Detroit	(313) 347-6800
CALIFORNIA , Los Angeles	(310) 417-8848	MINNESOTA , Minnetonka	(612) 932-1500
CALIFORNIA , Irvine	(714) 753-7360	MISSOURI , St. Louis	(314) 275-7380
CALIFORNIA , Roseville	(916) 922-7152	NEW JERSEY , Fairfield	(201) 808-2400
CALIFORNIA , San Diego	(619) 541-2163	NEW YORK , Fairport	(716) 425-4000
CALIFORNIA , Sunnyvale	(408) 749-0510	NEW YORK , Hauppauge	(516) 361-7000
COLORADO , Colorado Springs	(719) 599-7497	NEW YORK , Poughkeepsie/Fishkill	(914) 473-8102
COLORADO , Denver	(303) 337-3434	NORTH CAROLINA , Raleigh	(919) 870-4355
CONNECTICUT , Wallingford	(203) 949-4100	OHIO , Cleveland	(216) 349-3100
FLORIDA , Maitland	(407) 628-2636	OHIO , Columbus Worthington	(614) 431-8492
FLORIDA , Pompano Beach/ Fort Lauderdale	(305) 486-9776	OHIO , Dayton	(513) 495-6800
FLORIDA , Clearwater	(813) 538-7750	OKLAHOMA , Tulsa	(800) 544-9496
GEORGIA , Atlanta	(404) 729-7100	OREGON , Portland	(503) 641-3681
IDAHO , Boise	(208) 323-9413	PENNSYLVANIA , Colmar Philadelphia/Horsham	(215) 997-1020 (215) 957-4100
ILLINOIS , Chicago/Hoffman Estates	(708) 490-9500	TENNESSEE , Knoxville	(615) 690-5593
INDIANA , Fort Wayne	(219) 436-5818	TEXAS , Austin	(512) 873-2000
INDIANA , Indianapolis	(317) 571-0400	TEXAS , Houston	(800) 343-2692
INDIANA , Kokomo	(317) 457-6634	TEXAS , Plano	(214) 516-5100
IOWA , Cedar Rapids	(319) 373-1328	VIRGINIA , Richmond	(804) 285-2100
KANSAS , Kansas City/Mission	(913) 451-8555	WASHINGTON , Bellevue Seattle Access	(206) 454-4160 (206) 622-9960
MARYLAND , Columbia	(410) 381-1570	WISCONSIN , Milwaukee/Brookfield	(414) 792-0122

CANADA

BRITISH COLUMBIA , Vancouver	(604) 293-7605
ONTARIO , Toronto	(416) 497-8181
ONTARIO , Ottawa	(613) 226-3491
QUEBEC , Montreal	(514) 731-6881

INTERNATIONAL

AUSTRALIA , Melbourne	(61-3)887-0711
AUSTRALIA , Sydney	(61-2)906-3855
BRAZIL , Sao Paulo	55(11)815-4200
CHINA , Beijing	86 505-2180
FINLAND , Helsinki	358-0-35161191
Car Phone	358(49)211501
FRANCE , Paris/Vanves	33(1)40 955 900
GERMANY , Langenhagen/ Hanover	49(511)789911
GERMANY , Munich	49 89 92103-0
GERMANY , Nuremberg	49 911 64-3044
GERMANY , Sindelfingen	49 7031 69 910
GERMANY , Wiesbaden	49 611 761921
HONG KONG , Kwai Fong	852-4808333
Tai Po	852-6668333
INDIA , Bangalore	(91-812)627094
ISRAEL , Tel Aviv	972(3)753-8222
ITALY , Milan	39(2)82201
JAPAN , Aizu	81(241)272231
JAPAN , Atsugi	81(0462)23-0761
JAPAN , Kumagaya	81(0485)26-2600
JAPAN , Kyushu	81(092)771-4212
JAPAN , Mito	81(0292)26-2340
JAPAN , Nagoya	81(052)232-1621
JAPAN , Osaka	81(06)305-1801
JAPAN , Sendai	81(22)268-4333
JAPAN , Tachikawa	81(0425)23-6700
JAPAN , Tokyo	81(03)3440-3311
JAPAN , Yokohama	81(045)472-2751
KOREA , Pusan	82(51)4635-035
KOREA , Seoul	82(2)554-5188

MALAYSIA , Penang	60(4)374514
MEXICO , Mexico City	52(5)282-2864
MEXICO , Guadalajara	52(36)21-8977
Marketing	52(36)21-9023
Customer Service	52(36)669-9160
NETHERLANDS , Best	(31)49988 612 11
PUERTO RICO , San Juan	(809)793-2170
SINGAPORE	(65)2945438
SPAIN , Madrid	34(1)457-8204
or	34(1)457-8254
SWEDEN , Solna	46(8)734-8800
SWITZERLAND , Geneva	41(22)7991111
SWITZERLAND , Zurich	41(1)730 4074
TAIWAN , Taipei	886(2)717-7089
THAILAND , Bangkok	(66-2)254-4910
UNITED KINGDOM , Aylesbury	44(296)395-252

FULL LINE REPRESENTATIVES

COLORADO , Grand Junction	
Cheryl Lee Whltely	(303) 243-9658
KANSAS , Wichita	
Melinda Shores/Kelly Greiving	(316) 838 0190
NEVADA , Reno	
Galena Technology Group	(702) 746 0642
NEW MEXICO , Albuquerque	
S&S Technologies, Inc.	(505) 298-7177
UTAH , Salt Lake City	
Utah Component Sales, Inc.	(801) 561-5099
WASHINGTON , Spokane	
Doug Kenley	(509) 924-2322
ARGENTINA , Buenos Aires	
Argonics, S.A.	(541) 343-1787

HYBRID COMPONENTS RESELLERS

Elmo Semiconductor	(818) 768-7400
Minco Technology Labs Inc.	(512) 834-2022
Semi Dice Inc.	(310) 594-4631

TABLE OF CONTENTS

Paragraph Number	Title	Page Number
Section 1		
Introduction		
1.1	Block Diagram.....	1-1
1.2	Features	1-2
1.3	LC302 Applications	1-3
1.4	LC302 Differences	1-3
Section 2		
Configuration, Clocking, Low Power Modes, and Internal Memory Map		
2.1	MC68LC302 and MC68302 Signal Differences	2-1
2.2	IMP Configuration Control.....	2-2
2.2.1	Base Address Register	2-4
2.3	System Configuration Registers.....	2-5
2.4	Clock Generation and Low Power Control	2-5
2.4.1	PLL and Oscillator Changes to IMP	2-5
2.4.1.1	Clock Control Register	2-6
2.4.2	MC68LC302 System Clock Generation	2-6
2.4.2.1	Default System Clock Generation	2-7
2.4.3	IMP System Clock Generation	2-8
2.4.3.1	System Clock Configuration.....	2-8
2.4.3.2	On-Chip Oscillator.....	2-8
2.4.3.3	Phase-Locked Loop (PLL)	2-9
2.4.3.4	Frequency Multiplication	2-9
2.4.3.4.1	Low Power PLL Clock Divider.....	2-10
2.4.3.4.2	IMP PLL and Clock Control Register (IPLCR)	2-10
2.4.3.5	IMP Internal Clock Signals.....	2-12
2.4.3.5.1	IMP System Clock.....	2-12
2.4.3.5.2	BRG Clock	2-12
2.4.3.5.3	PIT Clock.....	2-12
2.4.3.6	IMP PLL Pins	2-12
2.4.3.6.1	VCCSYN	2-12
2.4.3.6.2	GNDSYN.....	2-12
2.4.3.6.3	XFC	2-12
2.4.3.6.4	MODCLK.....	2-12
2.4.4	IMP Power Management.....	2-13
2.4.4.1	IMP Low Power Modes	2-13
2.4.4.1.1	STOP Mode	2-13
2.4.4.1.2	DOZE Mode	2-13
2.4.4.1.3	STAND_BY Mode	2-13

Paragraph Number	Title	Page Number
2.4.4.1.4	SLOW_GO Mode.....	2-14
2.4.4.1.5	NORMAL Mode.....	2-14
2.4.4.1.6	IMP Operation Mode Control Register (IOMCR)	2-14
2.4.4.1.7	Low Power Drive Control Register (LPDCR)	2-15
2.4.4.1.8	IMP Power Down Register (IPWRD)	2-15
2.4.4.1.9	Default Operation Modes	2-15
2.4.4.2	Low Power Support.....	2-15
2.4.4.2.1	Enter the SLOW_GO mode	2-15
2.4.4.2.2	Entering the STOP/ DOZE/ STAND_BY Mode.....	2-16
2.4.4.2.3	IMP Wake-Up from Low Power STOP Modes	2-17
2.4.4.2.4	IMP Wake-Up Control Register (IWUCR)	2-17
2.4.4.3	Fast Wake-Up	2-18
2.4.4.3.5	Ring Oscillator Control Register (RINGOCR)	2-19
2.4.4.3.6	Ring Oscillator Event Register (RINGOEVR)	2-20
2.5	MC68LC302 Dual Port RAM.....	2-20
2.6	Internal Registers map	2-23

Section 3 System Integration Block (SIB)

3.1	System Control	3-1
3.1.1	System Control Register (SCR)	3-2
3.1.2	System Status Bits	3-3
3.1.3	System Control Bits	3-3
3.1.4	Freeze Control	3-5
3.1.5	Hardware Watchdog	3-5
3.2	Programmable Data Bus Size Switch	3-6
3.2.1	Bus Switch Register (BSR)	3-6
3.2.2	Basic Procedure:.....	3-6
3.3	Load Boot Code from An SCC	3-7
3.4	DMA Control	3-10
3.4.1	MC68LC302 Differences.....	3-10
3.4.2	IDMA Registers (Independent DMA Controller)	3-11
3.4.2.1	Channel Mode Register (CMR).....	3-11
3.4.2.2	Source Address Pointer Register (SAPR)	3-13
3.4.2.3	Destination Address Pointer Register (DAPR).....	3-13
3.4.2.4	Function Code Register (FCR)	3-13
3.4.2.5	Byte Count Register (BCR).....	3-13
3.4.2.6	Channel Status Register (CSR)	3-13
3.5	Interrupt Controller	3-14
3.5.1	Interrupt Controller Key Differences.....	3-14
3.5.2	Interrupt Controller Programming Model.....	3-14
3.5.2.1	Global Interrupt Mode Register (GIMR)	3-14
3.5.2.2	Interrupt Pending Register (IPR).....	3-15
3.5.2.3	Interrupt Mask Register (IMR).....	3-16
3.5.2.4	Interrupt In-Service Register (ISR).....	3-16

Paragraph Number	Title	Page Number
3.6	Parallel I/O Ports	3-17
3.6.1	Parallel I/O Port Differences.....	3-17
3.6.2	Port A	3-17
3.6.3	Port B	3-18
3.6.3.1	PB7–PB3.....	3-18
3.6.3.2	PB11–PB8.....	3-18
3.6.4	Port N	3-19
3.6.5	Port Registers.....	3-19
3.7	Timers	3-20
3.7.1	MC68LC302 General Purpose Timer Difference	3-20
3.7.2	General Purpose Timers Programming Mode.....	3-20
3.7.2.1	Timer Mode Register (TMR1, TMR2).....	3-20
3.7.2.2	Timer Reference Registers (TRR1, TRR2)	3-21
3.7.2.3	Timer Capture Registers (TCR1, TCR2)	3-21
3.7.2.4	Timer Counter (TCN1, TCN2)	3-21
3.7.2.5	Timer Event Registers (TER1, TER2)	3-21
3.7.3	Timer 3 - Software Watchdog Timer	3-22
3.7.3.1	Software Watchdog Reference Register (WRR)	3-22
3.7.3.2	Software Watchdog Counter (WCN)	3-22
3.7.4	Periodic Interrupt Timer (PIT).....	3-22
3.7.4.1	Overview	3-23
3.7.4.2	Periodic Timer Period Calculation	3-23
3.7.4.3	Using the Periodic Timer As a Real-Time Clock	3-24
3.7.4.4	Periodic Interrupt Timer Register (PITR).....	3-24
3.8	External Chip-Select Signals and Wait-State Logic	3-25
3.8.1	Chip-Select Registers.....	3-26
3.8.1.1	Base Register (BR3–BR0)	3-26
3.8.1.2	Option Registers (OR3–OR0)	3-26
3.8.2	Disable CPU Logic (M68000).....	3-28
3.8.3	Bus Arbitration Logic	3-28
3.8.3.1	Internal Bus Arbitration.....	3-28
3.8.3.2	External Bus Arbitration.....	3-28
3.9	Dynamic RAM Refresh Controller	3-29

Section 4

Communications Processor (CP)

4.1	MC68LC302 Key Differences from the MC68302	4-1
4.2	Serial Channels Physical Interface.....	4-2
4.2.1	Serial Interface Registers	4-2
4.2.1.1	Serial Interface Mode Register (SIMODE)	4-2
4.2.1.2	Serial Interface Mask Register (SIMASK)	4-4
4.3	Serial Communication Controllers (SCCs)	4-4
4.3.1	SCC Configuration Register (SCON)	4-4
4.3.1.1	Divide by 2 Input Blocks (New Feature)	4-4
4.3.2	Disable SCC1 Serial Clocks Out (DISC)	4-4
4.3.2.1	RCLK1 and TCLK1 Pin Options	4-5

Paragraph Number	Title	Page Number
4.3.3	SCC Mode Register (SCM).....	4-5
4.3.4	SCC Data Synchronization Register (DSR).....	4-6
4.3.5	Buffer Descriptors Table	4-6
4.3.6	SCC Parameter RAM Memory Map.....	4-7
4.3.7	Interrupt Mechanism	4-7
4.3.8	UART Controller.....	4-7
4.3.8.1	UART Memory Map	4-7
4.3.8.2	UART Mode Register.....	4-8
4.3.8.3	UART Receive Buffer Descriptor (Rx BD)	4-8
4.3.8.4	UART Transmit Buffer Descriptor (Tx BD).....	4-8
4.3.8.5	UART Event Register.....	4-9
4.3.8.6	UART MASK Register.....	4-9
4.3.9	Autobaud Controller (New)	4-9
4.3.9.1	Autobaud Channel Reception Process	4-9
4.3.9.2	Autobaud Channel Transmit Process	4-11
4.3.9.3	Autobaud Parameter RAM.....	4-11
4.3.9.4	Autobaud Programming Model	4-13
4.3.9.4.1	Preparing for the Autobaud Process.....	4-13
4.3.9.4.2	Enter_Baud_Hunt Command.....	4-14
4.3.9.4.3	Autobaud Command Descriptor.....	4-14
4.3.9.4.4	Autobaud Lookup Table.....	4-15
4.3.9.5	Lookup Table Example	4-17
4.3.9.6	Determining Character Length and Parity.....	4-17
4.3.9.7	Autobaud Reception Error Handling Procedure.....	4-18
4.3.9.8	Autobaud Transmission	4-18
4.3.9.8.1	Automatic Echo.....	4-19
4.3.9.8.2	Smart Echo	4-19
4.3.9.9	Reprogramming to UART Mode or Another Protocol	4-20
4.3.10	HDLC Controller.....	4-20
4.3.10.1	HDLC Memory Map	4-20
4.3.10.2	HDLC Mode Register.....	4-20
4.3.10.3	HDLC Receive Buffer Descriptor (Rx BD)	4-21
4.3.10.4	HDLC Transmit Buffer Descriptor (Tx BD).....	4-21
4.3.10.5	HDLC Event Register.....	4-21
4.3.10.6	HDLC Mask Register	4-21
4.3.11	BISYNC Controller	4-22
4.3.11.1	BISYNC Memory Map.....	4-22
4.3.11.2	BISYNC Mode Register	4-22
4.3.11.3	BISYNC Receive Buffer Descriptor (Rx BD).....	4-22
4.3.11.4	BISYNC Transmit Buffer Descriptor (Tx BD).....	4-22
4.3.11.5	BISYNC Event Register	4-23
4.3.11.6	BISYNC Mask Register.....	4-23
4.3.12	Transparent Controller	4-23
4.3.12.1	Transparent Memory Map.....	4-23
4.3.12.2	Transparent Mode Register	4-24

Paragraph Number	Title	Page Number
4.3.12.3	Transparent Receive Buffer Descriptor (RxB D)	4-24
4.3.12.4	Transparent Transmit Buffer Descriptor (Tx BD).....	4-25
4.3.12.5	Transparent Event Register	4-25
4.3.12.6	Transparent Mask Register	4-25
4.4	Serial Communication Port (SCP).....	4-25
4.4.1	SCP Programming Model.....	4-25
4.4.2	SCP Transmit/Receive Buffer Descriptor	4-26
4.5	Serial Management Controllers (SMCs).....	4-26
4.5.1	SMC Programming Model.....	4-26
4.5.2	SMC Memory Structure and Buffers Descriptors	4-26
4.5.2.1	SMC1 Receive Buffer Descriptor	4-26
4.5.2.2	SMC1 Transmit Buffer Descriptor	4-26
4.5.2.3	SMC2 Receive Buffer Descriptor	4-27
4.5.2.4	SMC2 Transmit Buffer Descriptor	4-27

Section 5 Signal Description

5.1	Functional Groups.....	5-1
5.2	Power Pins	5-2
5.3	Clock Pins	5-4
5.4	System Control Pins.....	5-5
5.5	Address Bus Pins (A19–A1).....	5-7
5.6	Data Bus Pins (D15—D0)	5-8
5.7	Bus Control Pins.....	5-9
5.8	Bus Arbitration Pins.....	5-10
5.9	Interrupt Control Pins	5-11
5.10	MC68LC302 Bus Interface Signal Summary.....	5-12
5.11	Physical Layer Serial Interface Pins.....	5-14
5.12	Typical Serial Interface Pin Configurations	5-14
5.13	NMSI1 or ISDN Interface Pins.....	5-14
5.14	NMSI2 Port or Port a Pins	5-17
5.15	PAIO / SCP Pins	5-18
5.16	Timer Pins	5-19
5.17	Parallel I/O Pins with Interrupt Capability	5-20
5.18	Chip-Select Pins.....	5-21
5.19	When to Use Pullup Resistors.....	5-21

Section 6 Electrical Characteristics

6.1	Maximum Ratings.....	6-2
6.2	Thermal Characteristics	6-2
6.3	Power Considerations	6-3
6.4	Power Dissipation.....	6-4
6.5	DC Electrical Characteristics.....	6-5
6.6	DC Electrical Characteristics—NMSI1 in IDL Mode.....	6-6
6.7	AC Electrical Specifications—Clock Timing	6-6

Paragraph Number	Title	Page Number
6.7.1	AC Electrical Characteristics - IMP Phased Lock Loop (PLL) Characteristics	6-7
6.8	AC Electrical Specifications—IMP Bus Master Cycles	6-8
6.9	AC Electrical Specifications—DMA	6-13
6.10	AC Electrical Specifications—External Master Internal Asynchronous Read/Write Cycles	6-16
6.11	AC Electrical Specifications—External Master Internal Synchronous Read/Write Cycles	6-19
6.12	AC Electrical Specifications—Internal Master Internal Read/Write Cycles	6-23
6.13	AC Electrical Specifications—Chip-Select Timing Internal Master	6-24
6.14	AC Electrical Specifications—Chip-Select Timing External Master	6-25
6.15	AC Electrical Specifications—Parallel I/O	6-26
6.16	AC Electrical Specifications—Interrupts	6-26
6.17	AC Electrical Specifications—Timers.....	6-28
6.18	AC Electrical Specifications—Serial Communications Port	6-29
6.19	AC Electrical Specifications—IDL Timing)	6-30
6.20	AC Electrical Specifications—GCI Timing	6-32
6.21	AC Electrical Specifications—PCM Timing.....	6-34
6.22	AC Electrical Specifications—NMSI Timing.....	6-36

Section 7

Mechanical Data and Ordering Information

7.1	Pin Assignments	7-1
7.1.1	Pin Grid Array (PGA)	7-1
7.1.2	Surface Mount (TQFP).....	7-2
7.2	Package Dimensions	7-3
7.2.1	Pin Grid Array (PGA)	7-3
7.2.2	Surface Mount (TQFP).....	7-4
7.3	Ordering Information	7-5

SECTION 1 INTRODUCTION

Motorola has developed a low-cost version of the well-known MC68302 integrated multiprotocol processor (IMP) called the MC68LC302. Simply put, the LC302 is a traditional 68302 minus the third serial communication controller (SCC3) and has a new static 68000 core, a new timer and low power modes. It is packaged in a low profile 100 TQFP that reduces board space from the regular 68302, as well as making it suitable for use in height restricted applications such as PCMCIA.

The document fully describes all the differences between the LC302 and the regular 68302. Any feature not described in this document will operate as described in the *MC68302 User's Manual*. In addition this document contains the full set of electrical descriptions for the LC302, even though most of them are exactly the same as the 68302.

1.1 BLOCK DIAGRAM

The block diagram is shown in Figure 1-1.

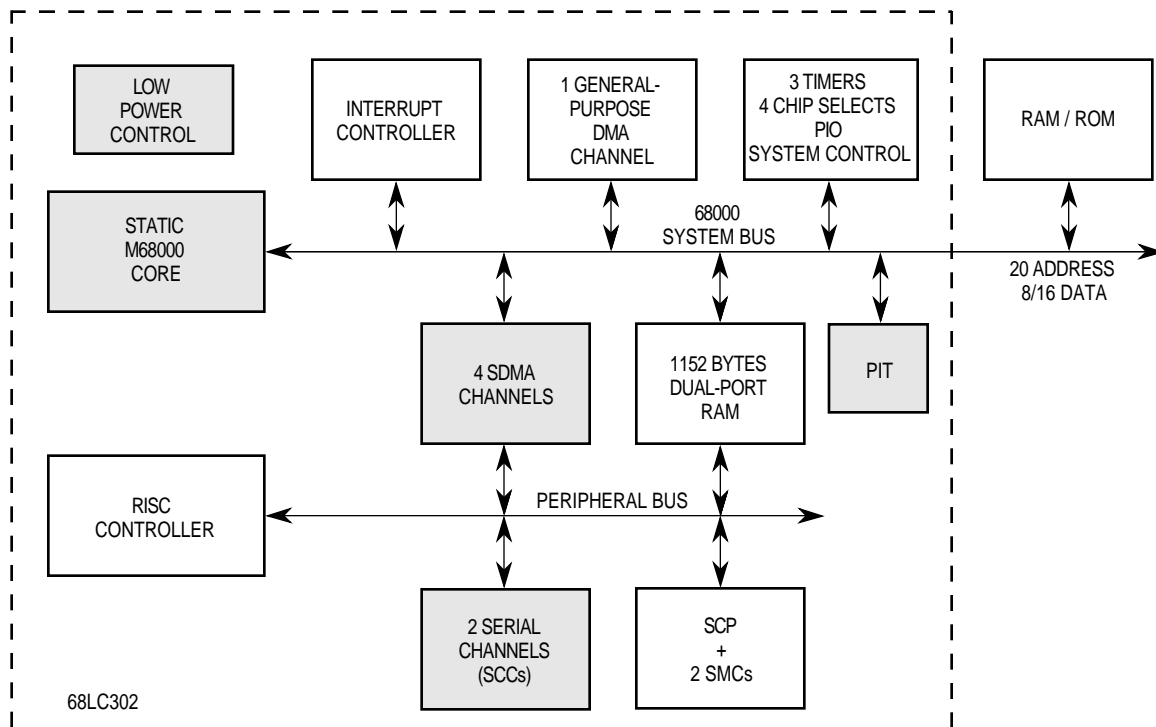

Figure 1-1. MC68LC302 Block Diagram

1.2 FEATURES

The features of the LC302 are as follows. The items in **bold face** type show major differences from the MC68302, although a complete list of differences is given in 1.4 LC302 Differences.

- On-Chip **Static 68000 Core** Supporting a 16- or 8-Bit M68000 Family-System
- SIB Including:
 - Independent Direct Memory Access (IDMA) Controller.
 - Interrupt Controller with Two Modes of Operation
 - Parallel Input/Output (I/O) Ports, some with Interrupt Capability
 - Parallel Input/Output (I/O) Ports on D15-D8 in 8 bit mode**
 - On-Chip 1152-Byte Dual-Port RAM
 - Three Timers Including a Watchdog Timer
 - New Periodic Interrupt Timer (PIT)**
 - Four Programmable Chip-Select Lines with Wait-State Generator Logic
 - Programmable Address Mapping of the Dual-Port RAM and IMP Registers
 - On-Chip Clock Generator with Output Signal
 - On-Chip PLL Allows Operation with 32kHz or 4MHz Crystals**
 - Glueless Interface to EPROM, SRAM, Flash EPROM, and EEPROM**
 - Allows Boot in 8-bit Mode, and Running Switch to 16-bit Mode**
 - System Control:
 - System Status and Control Logic
 - Disable CPU Logic (Slave Mode Operation)
 - Hardware Watchdog
 - New Low-Power (Standby) Modes With Wake-up From 2 Pins or PIT**
 - Freeze Control for Debugging (Available Only in the PGA Package)
 - DRAM Refresh Controller
- CP Including:
 - Main Controller (RISC Processor)
 - Two Independent Full-Duplex Serial Communications Controllers (SCCs)**
 - Supporting Various Protocols:
 - High-Level/Synchronous Data Link Control (HDLC/SDLC)
 - Universal Asynchronous Receiver Transmitter (UART)
 - Binary Synchronous Communication (BISYNC)
 - Transparent Modes
 - Autobaud Support Instead of DDCMP and V.110**
 - Boot from SCC Capability**

Four Serial DMA Channels for the Two SCCs

Flexible Physical Interface Accessible by SCCs Including:

Motorola Interchip Digital Link (IDL)

General Circuit Interface (GCI, Also Known as IOM¹-2)

Pulse Code Modulation (PCM) Highway Interface

Nonmultiplexed Serial Interface (NMSI) Implementing Standard

Modem Signals

SCP for Synchronous Communication

Two Serial Management Controllers (SMCs) To Support IDL and GCI Auxiliary Channels

- **100 Pin Thin Quad Flat Pack (TQFP) Packaging**

1.3 LC302 APPLICATIONS

The LC302 excels in several applications areas.

First, any application using the 68302, but not needing all three serial channels is a potential candidate for the LC302. Note however, that the LC302 sacrifices most of the provision for external bus mastership, thus the LC302 may not be appropriate where the 68302 is used as part of larger systems.

Second, the LC302 excels in low power and portable applications. The inclusion of a static 68000 core coupled with the low power modes built into the device make it ideal for hand-held, or other low power applications. The new 32 kHz or 4 MHz PLL option greatly reduces the total power budget of the designer's board, and allows the LC302 to be an effective device in low power systems. The LC302 can then optionally generate a full frequency clock for use by the rest of the board. During low power modes, the new periodic interrupt timer (PIT) allows the device to be woken up at regular intervals. In addition, two pins allow the device to be woken up from low power modes.

Third, given that the LC302 is packaged in a 100TQFP package, it allows the 68302 to be used in space critical applications, as well as height critical applications such as PCMCIA cards.

Fourth, since the disable CPU mode (also known as slave mode) is still retained, the LC302 can function as a fully intelligent DMA-driven peripheral chip containing serial channels, timers, and chip selects, etc.

1.4 LC302 DIFFERENCES

The LC302 has some specific differences from the 68302. Most of these differences simply result from the reduction in pins from 132 on the original 68302, to 100 pins on the LC302.

¹ IOM is a trademark of Siemens AG

The following features have been removed or modified from the 68302 in order to make the LC302 possible.

- SCC3 and its baud rate generator (BRG3) are removed.
- External masters are not able to take the bus away from the LC302 except through a simple scheme using the HALT pin. This restriction does not apply to using the LC302 in CPU disabled mode (slave mode), in which case BR, BG, and BGACK are all available (they replace the IPL2-0 pins).
- Although the Independent DMA (IDMA) is still available, the external IDMA request pins (DREQ, DACK, and DONE) have been eliminated.
- Four address lines have been eliminated, giving a total of 20 address lines. However, the LC302 supports more than a 1 MB addressing range, since each of the four chip selects still decodes a 24-bit address. This allows a total of 4 MB to be addressed.
- Since the function code pins and AVEC have been removed, interrupt acknowledgment to external devices is only provided on levels one, six, and seven.
- The DDCMP and V.110 protocols have been removed.
- The total list of pins removed is: A23-A20, FC2-FC0[†], AVEC[†], RMC, IAC[†], BERR, BR, BG, BGACK, BCLR, IACK1, IACK6, IACK7, DREQ, DACK, DONE, BRG1, FRZ[†], TOUT1, NC1, NC3, TCLK3, RTS3, CTS3, CD3, plus 5 power and ground pins.

NOTE

Signals marked with [†] are available in the PGA Package.

- The SCP pins are now muxed with PA8, PA9, and PA10. The TXD3, RXD3, and RCLK3 functions associated with SCC3 are eliminated.
- The UDS, LDS, and R/W pins are not available except in slave mode, where they replace the WEH, WEL, and OE pins. Instead, the new pins WEH, WEL, and OE have been defined for glueless interfacing to memory.
- PA12 is now muxed with the MODCLK pin, which is associated with the 32 kHz or 4 MHz PLL. The MODCLK pin is sampled after reset, and then becomes PA12.
- New VCCsyn, GNDsyn, and XFC pins have been added in support of the on-chip PLL.
- For purposes of emulation support only, a special 132 PGA version is supported. This version adds back the FC2-0, IAC, FRZ, and AVEC pins. The FC2-0 pins allow bus cycles to be distinguished between program and data accesses, interrupt cycles, etc. The IAC, FRZ, and AVEC pins are provided so that emulation vendors can quickly retrofit their existing 68302 emulator designs to support the LC302.

SECTION 2

CONFIGURATION, CLOCKING, LOW POWER MODES, AND INTERNAL MEMORY MAP

The MC68LC302 integrates a high-speed M68000 processor with multiple communications peripherals. The provision of direct memory access (DMA) control and link layer management with the serial ports allows high throughput of data for communications-intensive applications, such as basic rate Integrated Services Digital Network (ISDN).

The MC68LC302 can operate either in the full MC68000 mode with a 16-bit data bus or in the MC68008 mode with an 8-bit data bus by connecting the bus width (BUSW) pin low.

NOTE

The BUSW pin is static and is not intended to be used for dynamic bus sizing. Instead the BSW and BSWEN bits in the BSR register should be used to switch the bus width after reset (3.2 Programmable Data Bus Size Switch). If the state of the BUSW pin is changed during operation of the MC68LC302, erratic operation may occur.

Refer to the MC68000UM/AD, *M68000 8-/16-/32-Bit Microprocessors User's Manual*, and the MC68302UM/AD, *MC68302 Integrated Multiprotocol Processor User's Manual*, for complete details of the on-chip microprocessor including the programming model and instruction set summary. Throughout this manual, references may use the notation M68000, meaning all devices belonging to this family of microprocessors, or the notation MC68000, MC68008, meaning the specific microprocessor products.

This section is intended to describe configuration of the MC68LC302 and the differences between the LC302 and the MC68000 and the MC68302. This section also includes tables that show the registers of the IMP portion of the MC68LC302. All of the registers are memory mapped into the 68000 space

2.1 MC68LC302 AND MC68302 SIGNAL DIFFERENCES

The MC68LC302 in CPU enable mode has Write Enable (\overline{WE}) signals instead of UDS and LDS signal. The Write Enable High ($\overline{WEH/A0}$) signal indicates that most significant data byte will be accessed, and the Write Enable Low ($\overline{WEL/DS}$) indicates that the least significant data byte will be accessed. When the core is disabled, $\overline{WEH/A0}$ and $\overline{WEL/DS}$ become $\overline{UDS/A0}$ and $\overline{LDS/DS}$ respectively.

The MC68LC302 in CPU enable mode has an output enable (\overline{OE}) signal instead of R/\overline{W} . The \overline{OE} signal indicates that the MC68LC302 expects an external device to drive data onto the data bus. When the core is disabled, \overline{OE} becomes the R/\overline{W} signal.

The MC68LC302 in CPU enable mode does not have \overline{BR} , \overline{BG} , and \overline{BGACK} pins. Instead the \overline{HALT} pin is used to force the MC68LC302 off of the bus (see the \overline{HALT} signal description in 5.4 System Control Pins). While the MC68LC302 is halted, the chip selects are still functional. The external master will not be able to access the internal registers and dual-port RAM.

When the core is disabled, the $\overline{IPL0}$, $\overline{IPL1}$, and $\overline{IPL2}$ lines become the \overline{BR} , \overline{BG} , and \overline{BGACK} signals. The only external interrupts handled are PB8, PB9, PB10, and PB11.

Two M6800 signals are omitted from the 68LC302: valid memory address (\overline{VMA}) and enable (E). The valid peripheral address (\overline{VPA}) signal which was used on the MC68302 as \overline{AVEC} has been removed from the MC68LC302.

The signals for the serial communications port (SCP) have been multiplexed with the PA8, PA9, and PA10 pins and the signals for SCC3 have been removed.

The FC2-0 pins have been removed from the MC68LC302. These signals are still driven internally by the core depending on the type of bus cycle (i.e. supervisor program space, supervisor data space, etc.) and the internal peripherals. They can still be used for address comparison in the chip select registers. In disable CPU mode and when \overline{HALT} is asserted for external masters, the FC signals are internally driven to 5 for external master accesses to internal peripherals.

The A23-A20 pins have been removed from the MC68LC302. These signals are still driven internally by the core and the internal peripherals. The user must program the full 24-bit address in the chip select base registers, option registers, and in the pointers used by the internal DMA and SCCs. In disable CPU mode and when \overline{HALT} is asserted for external masters, the A23-20 signals are driven to zero for all external master accesses.

The other signals removed from the MC68LC302 are IAC, \overline{RMC} , \overline{BLCR} , \overline{BERR} , \overline{FRZ} , BRG1, $\overline{DREQ}/PA13$, $\overline{DACK}/PA14$, $\overline{DONE}/PA15$, $\overline{IACK7}/PB0$, $\overline{IACK6}/PB1$, $\overline{IACK7}/PB2$, and $\overline{TOUT1}/PB4$.

The signals XFC and MODCLK (multiplexed with PA12) have been added for use with the on-chip phase lock loop.

For purposes of emulation support only, a special 132 PGA version is supported. This version adds back the FC2-0, IAC, \overline{FRZ} , and \overline{AVEC} pins.

2.2 IMP CONFIGURATION CONTROL

A number of reserved entries in the external M68000 exception vector table are used as addresses for the internal system configuration registers. See Table 2-1.

The BAR entry contains the BAR described in this section. The SCR entry contains the SCR described in Section 3 System Integration Block (SIB).

Figure 2-1 shows all the IMP on-chip addressable locations and how they are mapped into system memory.

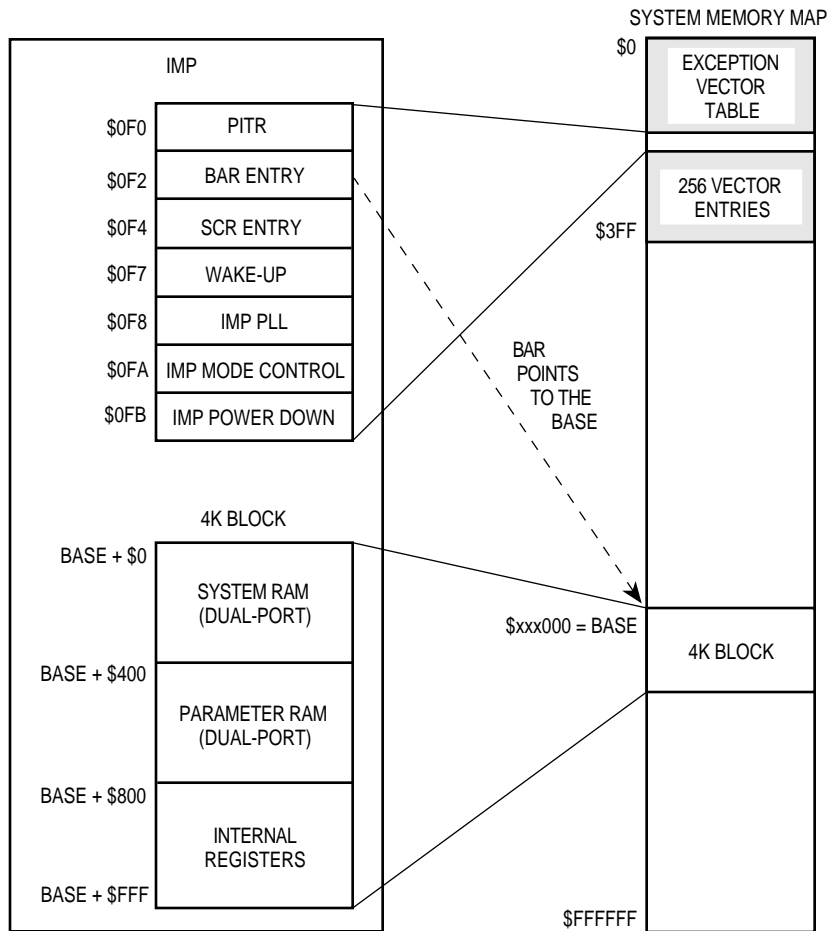

Figure 2-1. IMP Configuration Control

The on-chip peripherals, including those peripherals in both the communications processor (CP) and system integration block (SIB), require a 4K-byte block of address space. This 4K-byte block location is determined by writing the intended base address to the BAR in supervisor data space (FC = 5). The FC2-0 pins are internally driven by the MC68LC302 to supervisor data space.

After a total system reset, the on-chip peripheral base address is undefined, and it is not possible to access the on-chip peripherals at any address until BAR is written. The BAR and the SCR can always be accessed at their fixed addresses.

NOTE

The BAR and SCR registers are internally reset only when a total system reset occurs by the simultaneous assertion of $\overline{\text{RESET}}$

and $\overline{\text{HALT}}$. The chip-select ($\overline{\text{CS}}$) lines are not asserted on accesses to these locations. Thus, it is very helpful to use $\overline{\text{CS}}$ lines to select external ROM/RAM that overlaps the BAR and SCR register locations, since this prevents potential bus contention.

NOTE

In 8-bit system bus operation, IMP accesses are not possible until the low byte of the BAR is written. Since the MOVE.W instruction writes the high byte followed by the low byte, this instruction guarantees the entire word is written.

Do not assign other devices on the system bus an address that falls within the address range of the peripherals defined by the BAR. If this happens, an internal $\overline{\text{BERR}}$ is generated to the core (if the address decode conflict enable (ADCE) bit is set) and the address decode conflict (ADC) bit in the SCR is set.

2.2.1 Base Address Register

The BAR is a 16-bit, memory-mapped, read-write register consisting of the high address bits, the compare function code bit, and the function code bits. Upon a total system reset, its value may be read as \$BFFF, but its value is not valid until written by the user. The address of this register is fixed at \$0F2 in supervisor data space. BAR cannot be accessed in user data space.

15	13	12	11											0	
FC2-FC0			CFC	BASE ADDRESS											
				23	22	21	20	19	18	17	16	15	14	13	12

Bits 15–13—FC2–FC0

The FC2–FC0 field is contained in bits 15–13 of the BAR. These bits are used to set the address space of 4K-byte block of on-chip peripherals. The address compare logic uses these bits, dependent upon the CFC bit, to cause an address match within its address space. When the core is enabled, the function code bits will be driven by the core to indicate the type of cycle in process. In disable CPU mode, the FC pins are not present and are internally driven to 5. Since, the user does not have any control over how the FC signals are driven, it is recommended that the user write these bits to zero and write the CFC bit to zero to disable the FC comparison.

NOTE

Do not assign this field to the M68000 core interrupt acknowledge space (FC2–FC0 = 7).

CFC—Compare Function Code

- 0 = The FC bits in the BAR are ignored. Accesses to the IMP 4K-byte block occur without comparing the FC bits.
- 1 = The FC bits in the BAR are compared. The address space compare logic uses the FC bits to detect address matches.

Bits 11–0—Base Address

The high address field is contained in bit 11–0 of the BAR. These bits are used to set the starting address of the dual-port RAM. The address compare logic uses only the most significant bits to cause an address match within its block size. Even though A23–20 are signals are not available, they are driven internally by the core, or driven to zeroes in disable CPU mode or when $\overline{\text{HALT}}$ has been asserted by an external master.

2.3 SYSTEM CONFIGURATION REGISTERS

A number of entries in the M68000 exception vectors table (located in low RAM) are reserved for the addresses of system configuration registers (see Table 2-1). These registers have seven addresses within \$0F0-\$0FF. The MC68LC302 uses one of the IMP 32-bit reserved spaces for 3 registers added for the MC68LC302. These registers are used to control the PLL, clock generation and low power modes. See 2.4 Clock Generation and Low Power Control.

Table 2-1. System Configuration Registers

Address	Name	Width	Description	Reset Value
\$0F0	PITR	16	Periodic Interrupt Timer Register	0000
\$0F2	BAR	16	Base Address Register	BFFF
\$0F4	SCR	24	System Control Register	0000 0F
\$0F7	IWUCR	8	IMP Wake-Up Control Register	00
\$0F8	IPLCR	16	IMP PLL Control Register	
\$0FA	IOMCR	8	IMP Operations Mode Control Register	00
\$0FB	IPDR	8	IMP Power Down Register	00
\$0FC	RES	32	Reserved	

2.4 CLOCK GENERATION AND LOW POWER CONTROL

The MC68LC302 includes a clock circuit that consists of crystal oscillator drive circuit capable of driving either an external crystal or accepting an oscillator clock, a PLL clock synthesizer capable of multiplying a low frequency clock or crystal such as a 32-kHz watch crystal up to the maximum clock rate of each processor, and a low power divider which allows dynamic gear down and gear up of the system clock for each processor on the fly.

- **On-Chip Clock Synthesizers (with output system clocks)**
 - Oscillator Drive Circuits and Pins
 - PLL Clock Synthesizer Circuits with Low Power Output Clock Divider Block.
- **Low Power Control Of IMP**
 - Slow-Go Modes using PLL Clock Divider Blocks
 - Varied Low Power STOP Modes for Optimizing Wake-Up Time to Low Power Mode Power Consumption: Stand-By, Doze and STOP.

2.4.1 PLL and Oscillator Changes to IMP

The oscillator that was on the MC68302 has been replaced by the new clock synthesizer described in this section. The registers related to the oscillator have been either removed or

changed according to the description below. Several control bits are still available but have new locations.

The low power modes on the MC68302 have changed completely and will be discussed later in 2.4.4.1 IMP Low Power Modes.

2.4.1.1 CLOCK CONTROL REGISTER. The clock control register address \$FA is not implemented on the MC68LC302. This register location has been reassigned to the IOMCR and ICKCR registers. The clock control register bits have been reassigned as follows:

CLKO Drive Options (CLKOMOD1–2)

These bits are now in the IMP clock control register (IPLCR) on the MC68LC302, see 2.4.3.4.2 IMP PLL and Clock Control Register (IPLCR).

Three-State TCLK1 (TSTCLK1)

This bit is now in the DISC register on the MC68LC302, see 4.3.2 Disable SCC1 Serial Clocks Out (DISC).

Three-State RCLK1 (TSRCLK1)

This bit is now in the DISC register on the MC68LC302, see 4.3.2 Disable SCC1 Serial Clocks Out (DISC).

Disable BRG1 (DISBRG1)

This bit has been removed since the BRG1 pin was removed.

2.4.2 MC68LC302 System Clock Generation

Figure 2-3, the MC68LC302 system clock schematic, shows the IMP clock synthesizer. The block includes an on-chip oscillator, a clock synthesizer, and a low-power divider, which allows a comprehensive set of options for generating the system clock. The choices offer many opportunities to save power and system cost, without sacrificing flexibility and control. In addition to performing frequency multiplication, the PLL block can also provide EXTAL to CLKO skew elimination, and dynamic low power divides of the output PLL system clock.

Clock source and default settings are determined during the reset of the IMP. The MC68LC302 decodes the MODCLK and VCCSYN pins and the value of these pins determines the initial clocking for the part. Further changes to the clocking scheme can be made by software. After reset, the 68000 core can control the IMP clocking through the following registers:

1. IMP Operation Mode Control Register, IOMCR (2.4.4.1.6 IMP Operation Mode Control Register (IOMCR)).
2. IMP PLL and Clock Control Register, IPLCR (2.4.3.4 Frequency Multiplication).
3. IMP Interrupt Wake-Up Control Register, IWUCR (2.4.4.2.4 IMP Wake-Up Control Register (IWUCR)).
4. Periodic Interrupt Timer Register, PITR (See Section 3 System Integration Block (SIB)).

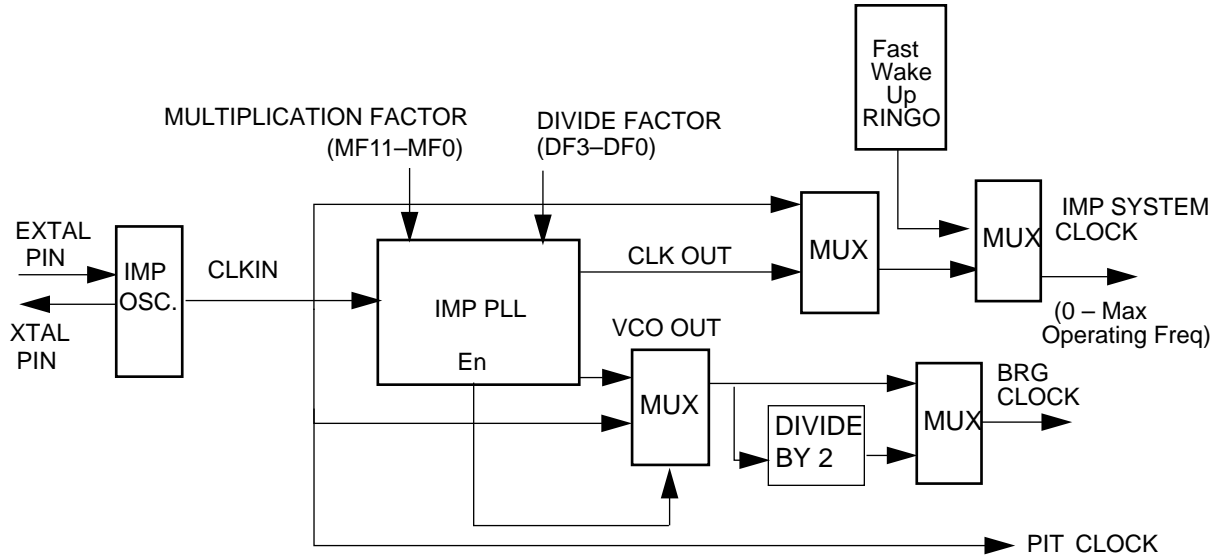

Figure 2-2. MC68LC302 PLL Clock Generation Schematic

2.4.2.1 DEFAULT SYSTEM CLOCK GENERATION. During the assertion of hardware reset, the value of the MODCLK and VCCSYN input pins determine the initial PLL settings according to Table 2-2. After the deassertion of reset, these pins are ignored.

The MODCLK and VCCSYN pins control the IMP clock selection at hardware reset. The IMP PLL can be enabled or disabled at reset only and the multiplication factor preset to support different industry standard crystals. After reset, the multiplication factor can be changed in the IPLCR register, and the IMP PLL divide factor can be set in the IOMCR register.

NOTE

The IMP input frequency ranges are limited to between 25 kHz and the maximum operating frequency, and the PLL output frequency range before the low power divider is limited to between 10 MHz and the maximum system clock frequency (25 MHz).

Table 2-2. Default System Clock Generation

CSelect	VCCSYN MODCLK	Example IMP EXTAL Freq.	IMP PLL	IMP MF+1	IMP System Clock
0	0X	25 MHz	Disabled	x	IMP EXTAL
0	10	4.192 MHz	Enabled	4	IMP EXTALx4
0	11	32.768 kHz	Enabled	401	IMP EXTALx401

Note:

By loading the IPLCR register the user can change the multiplication factor of the PLL after RESET.

By loading the IOMCR register, the user can change the power saving divide factor of the IMP PLL.

NOTE

It is not possible to start the system with PLL disabled and then enable the PLL with software programming.

2.4.3 IMP System Clock Generation

2.4.3.1 SYSTEM CLOCK CONFIGURATION. The IMP has an on-chip oscillator and phased locked loop (Figure 2-2). These features provide flexible ways to save power and reduce system cost. The operation of the clock generation circuitry is determined by the following registers.

The IMP Operation Mode Control Register, IOMCR in 2.4.4.1.6 IMP Operation Mode Control Register (IOMCR).

The IMP PLL and Clock Control Register, IPLCR in A 32.768-kHz watch crystal provides an inexpensive reference, but the EXTAL reference crystal frequency can be any frequency from 25 kHz to 6.0 MHz. Additionally, the system clock frequency can be driven directly onto the EXTAL pin. In this case, the EXTAL frequency should be the exact system frequency desired (0 to Maximum Operating Frequency) and the XTAL pin should be left floating. Figure 2-4 shows all the external connections required for the on-chip oscillator (as well as the PLL, VCC, and GND connection).

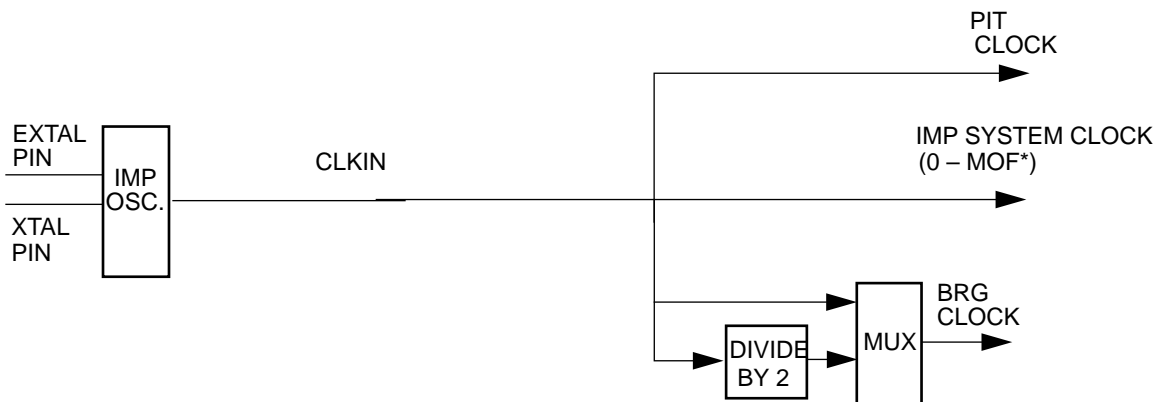

* MOF is Maximum Operating Frequency

Figure 2-3. IMP System Clocks Schematic - PLL Disabled

Figure 2-2 shows the IMP system clocks schematic with the IMP PLL enabled. Figure 2-3 shows the IMP system clocks schematic with the IMP PLL disabled.

The clock generation features of the IMP are discussed in the following paragraphs.

2.4.3.2 ON-CHIP OSCILLATOR. A 32.768-kHz watch crystal provides an inexpensive reference, but the EXTAL reference crystal frequency can be any frequency from 25 kHz to 6.0

MHz. Additionally, the system clock frequency can be driven directly onto the EXTAL pin. In this case, the EXTAL frequency should be the exact system frequency desired (0 to Maximum Operating Frequency) and the XTAL pin should be left floating. Figure 2-4 shows all the external connections required for the on-chip oscillator (as well as the PLL, VCC, and GND connection

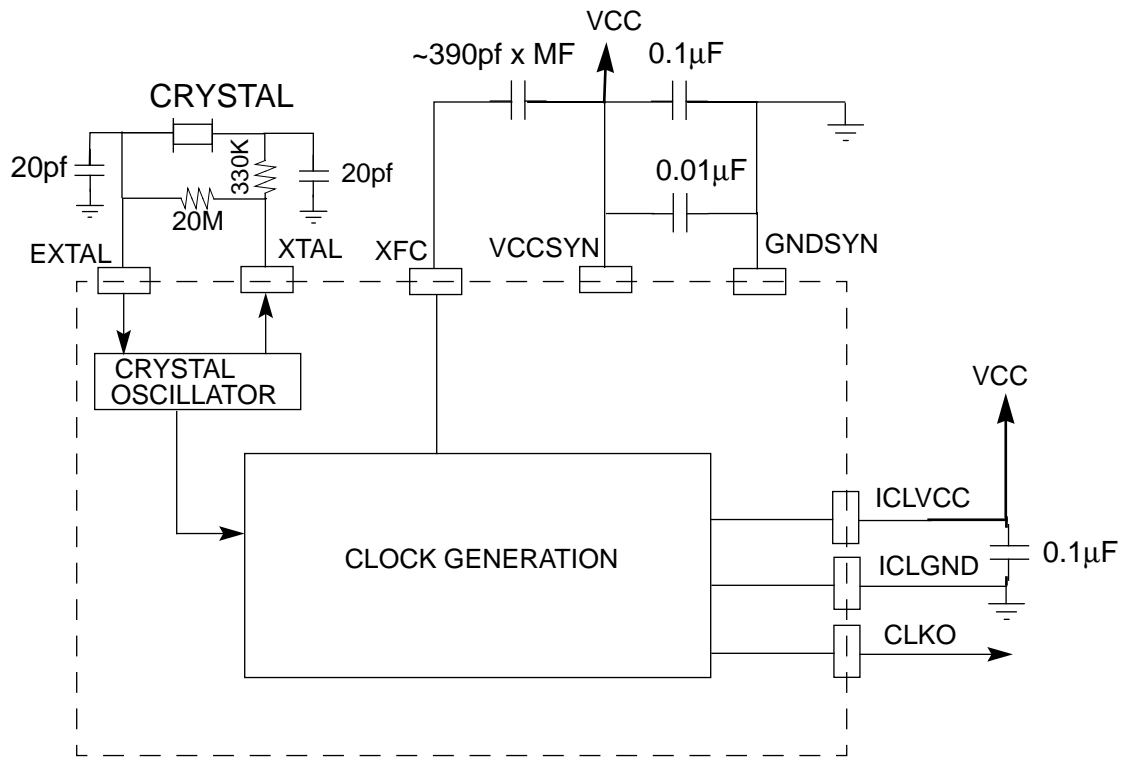

Figure 2-4. PLL External Components

2.4.3.3 PHASE-LOCKED LOOP (PLL). The IMP PLL’s main function is frequency multiplication. The phase-locked loop takes the CLKIN frequency and outputs a high-frequency source used to derive the general system frequency of the IMP. The IMP PLL is comprised of a phase detector, loop filter, voltage-controlled oscillator (VCO), and multiplication block.

2.4.3.4 FREQUENCY MULTIPLICATION. The IMP PLL can multiply the CLKIN input frequency by any integer between 1 and 4096. The multiplication factor may be changed to the desired value by writing the MF11–MF0 bits in the IPLCR. When the IMP PLL multiplier is modified in software, the IMP PLL will lose lock, and the clocking of the IMP will stop until lock is regained (worst case is 2500 EXTAL clocks). If an alteration in the system clock rate is desired without losing IMP PLL lock, the value in the low-power clock divider can be modified to lower the system clock rate dynamically. The low power clock divider bits are located in the IOMCR register.

NOTE

If IMP PLL is enabled, the multiplication value must be large enough to result in the VCO clock being greater than 10 MHz.

2.4.3.4.1 Low Power PLL Clock Divider. The output of the IMP VCO is sent to a low power divider block. The clock divider can divide the output frequency of the VCO before it generates the system clock. The clock for the baud rate generators (BRGs) bypasses this clock divider.

The purpose of the clock divider is to allow the user to reduce and restore the operating frequency of the IMP without losing the IMP’s PLL lock. Using the clock divider, the user can still obtain full IMP operation, but at a slower frequency. The BRG is not affected by the low power divider circuitry so previous BRG divider settings will not have to be changed when the divide factors are changed.

When the PLL low power divider bits (DF0–3) are programmed to a non-zero value, the IMP is in SLOW_GO mode. The selection and speed of the SLOW_GO mode may be changed at any time, with changes occurring immediately.

NOTE

The IMP low power clock divider is active only if the IMP PLL is active.

The low-power divider block is controlled in the IOMCR. The default state of the low-power divider is to divide all clocks by 1.

If the low-power divider block is not used and the user is concerned that errant software could accidentally write the IOMCR, the user may set a write protection bit in IOMCR to prevent further writes to the register.

2.4.3.4.2 IMP PLL and Clock Control Register (IPLCR). IPLCR is a 16-bit read/write register used to control the IMP’s PLL, multiplication factor and CLKO drive strength. This register is mapped in the 68000 bus space at address \$0F8. If the 68000 bus is set to 8 bits (BUSW grounded at reset), during 8-bit accesses, changes to the IPLCR will take effect in the IMP PLL after loading the high byte of IPLCR (the low byte is written first). The WP bit in IPLCR is used as a protect mechanism to prevent erroneous writing. When this bit is set further accesses to the IPLCR will be blocked.

IMP PLL and Clock Control Register (IPLCR) \$0F8

	15	14	13	12	11	10	9	8
	IPLWP	CLKOMOD0–1		PEN	MF11	MF10	MF9	MF8
RESET	0	0	0	VCCSYN	0	0	0	VCCSYNMODCLK
	7	6	5	4	3	2	1	0
	MF7	MF6	MF5	MF4	MF3	MF2	MF1	MF0
RESET	VCCSYNMODCLK1	0	0	VCCSYNMODCLK	0	0	MODCLK	MODCLK

Read/Write

MF 11–0—Multiplication Factor

These bits define the multiplication factor that will be applied to the IMP PLL input frequency. The multiplication factor can be any integer from 1 to 4096. The system frequency is $((MF \text{ bits} + 1) \times EXTAL)$. The multiplication factor must be chosen to ensure that the resulting VCO output frequency will be in the range from 10 MHz to the maximum allowed clock input frequency (e.g. 20 MHz for a 20 MHz IMP).

The value 000 results in a multiplier value of 1. The value \$FFF results in a multiplier value of 4096.

Any time a new value is written into the MF11–MF0 bits, the IMP PLL will lose the lock condition, and after a delay of 2500 EXTAL clocks, will relock. When the IMP PLL loses its lock condition, all the clocks that are generated by the IMP PLL are disabled. After hardware reset, the MF11–MF0 bits default to either 0, 3 or 400 (\$190 hex) depending on the MODCLK and VCCSYN pins (giving a multiplication factor of 1, 4 or 401). If the multiplication factor is 401, then a standard 32.768 kHz crystal generates an initial general system clock of 13.14 MHz. If the multiplication factor is 4, then a standard 4.192 MHz crystal generates an initial general system clock of 16.768 MHz. The user would then write the MF bits or adjust the output frequency to the desired frequency.

NOTE

Since the clock source for the periodic interrupt timer is CLKIN (see Figure 2-2), the PIT timer is not disturbed when the IMP PLL is in the process of acquiring lock.

PEN—PLL Enable Bit

The PEN bit indicates whether the IMP PLL is operating. This bit is written by the MC68LC302 based on the value of VCCSYN during reset. When the IMP PLL is disabled, the VCO is not operating in order to minimize power consumption. During hardware reset this bit is set if the VCCSYN pin specifies that the IMP PLL is enabled. The only way to clear PEN is to hold the VCCSYN pin low during a hardware reset.

0 = The IMP PLL is disabled. Clocks are derived directly from the EXTAL pin.

1 = The IMP PLL is enabled. Clocks are derived from the CLKOUT output of the PLL.

CLKODM0–1—CLKO Drive Mode 0–1

These bits control the output buffer strength of the CLKO pin. Those bits can be dynamically changed without generating spikes on the CLKO pin. Disabling CLKO will save power and reduce noise.

00 = Clock Out Enabled, Full-Strength Output Buffer.

01 = Clock Out Enabled, 2/3-Strength Output Buffer

10 = Clock Out Enabled, 1/3-Strength Output Buffer

11 = Clock Out Disabled (CLKO is driven high by internal pullup)

NOTE

These IMP bits are in a different address location than in the MC68302, where they are located at address \$FA (bits 15, 14).

IPLWP—IMP PLL Control Write Protect Bit

This bit prevents accidental writing into the IPLCR. After reset, this bit defaults to zero to enable writing. Setting this bit prevents further writing (excluding the first write that sets this bit).

2.4.3.5 IMP INTERNAL CLOCK SIGNALS. The following paragraphs describe the IMP internal clock signals.

2.4.3.5.1 IMP System Clock. The IMP system clock is supplied to all modules on the IMP (with the exception of the BRG clocks which are connected directly to the VCO output with the PLL enabled). The IMP can be programmed to operate with or without IMP PLL. If IMP PLL is active, the system clock will be driven by PLL clock divider output. If IMP PLL is not active, the system clock will be driven by the PLL input clock (CLKIN).

2.4.3.5.2 BRG Clock. The clock to the BRGs can be supplied from the IMP PLL input (CLKIN) when the IMP PLL is disabled, or from the IMP PLL VCO output (when the PLL is enabled). The BRG prescaler input clock may be optionally programmed to be divided by 2 to allow very low baud rates to be generated from the system clock by setting the BCD bit in the IOMCR.

2.4.3.5.3 PIT Clock. CLKIN is supplied to the periodic interrupt timer (PIT) submodule which allows the PIT clock to run independently of the system clock (refer to Figure 2-2 and Section 3 System Integration Block (SIB)).

2.4.3.6 IMP PLL PINS. The following pins are dedicated to the IMP PLL operation.

2.4.3.6.1 VCCSYN. This pin is the V_{CC} dedicated to the analog IMP PLL circuits. The voltage should be well regulated, and the pin should be provided with an extremely low-impedance path to the V_{CC} power rail if the PLL is to be enabled. VCCSYN should be bypassed to GNDSYN by a 0.1- μ F capacitor located as close as possible to the chip package. VCCSYN should be tied to ground if the PLL is to be disabled.

2.4.3.6.2 GNDSYN. This pin is the GND dedicated to the analog IMP PLL circuits. The pin should be provided with an extremely low-impedance path to ground. GNDSYN should be bypassed to VCCSYN by a 0.1 μ F capacitor located as close as possible to the chip package. The user should also bypass GNDSYN to VCCSYN with a 0.01 μ F capacitor as close as possible to the chip package.

2.4.3.6.3 XFC. This pin connects to the off-chip capacitor for the PLL filter. One terminal of the capacitor is connected to XFC; the other terminal is connected to IQVCC.

2.4.3.6.4 MODCLK. MODCLK specifies what the initial VCO frequency is after a hardware reset if VCCSYN is tied high. During the assertion of RESET, the value of the VCCSYN and MODCLK input pins causes the PEN bit and the MF11–0 bits of the IMP PLL and Clock Control Register (IPLCR) \$0F8 to be appropriately written. VCCSYN and MODCLK also determines if the oscillator's prescaler is used. After RESET is negated, the MODCLK pins is ignored and becomes PA12. Table 2-2 shows the combinations of VCCSYN and MODCLK pins with the corresponding default settings.

2.4.4 IMP Power Management

The IMP portion of the MC68LC302 has several low power modes from which to choose.

2.4.4.1 IMP LOW POWER MODES. The MC68LC302 provides a number of low power modes for the IMP section. Each of the operation modes has different current consumption, wake-up time, and functionality characteristics. The state of the IMP's 68000 data and address bus lines can be either driven high, low or high impedance during low power stop mode by programming the low power drive control register (LPDCR).

NOTE

For lowest current consumption, the SCCs and BRGs should be disabled before entering the low power modes. Current consumption for all operating modes is specified in Section 6 Electrical Characteristics.

Table 2-3. IMP Low Power Modes - IMP PLL Enabled

Operation Mode	Oscillator	PLL	IMP Clock	Wake_Up (Osc. Clock Cycles)	Current Consumption (Approximate)	Method of Entry/ LPM bits	IMP Functionality
STOP	Not Active	Not active	Not active	70000 osc. clocks	<0.1mA	Stop instruction/ LPM1-0=11	No
DOZE	Active	Not active	Not active	2500 osc clocks	About 500uA	Stop instruction/ LPM1-0=10	No
STAND_BY	Active	Active (if enabled)	Not active	2-5 system clock cycles	About 5mA	Stop instruction/ LPM1-0=01	Partial (BRG clock is active)
SLOW_GO/ NORMAL	Active	Active (if enabled)	Active		Low, depends on CLK freq.	Write to DF3-0	Full

2.4.4.1.1 STOP Mode. In STOP mode, all parts of IMP are inactive and the current consumption is less than 0.1mA. Both the crystal oscillator and the IMP PLL are shut down. Because both the oscillator and the PLL must start up, the wake-up time takes 70000 EXTAL clocks (for example, 70000 cycles of 32.768 kHz crystal will take about 2.2 seconds).

The STOP mode is entered by executing the STOP instruction with the LPM0-1 bits in the IOMCR register set to 11. Refer to 2.4.4.2 Entering the STOP/ DOZE/ STAND_BY Mode for an example instruction sequence for use with the STOP instruction.

2.4.4.1.2 DOZE Mode. In DOZE mode, the oscillator is active in the IMP but the IMP PLL is shut down. The current consumption depends on the frequency of the external crystal but is on the order of 500 μ A. In DOZE mode, the IMP is shut down. The wake-up time is 2500 cycles of the external crystal (for example, 2500 cycles of 32.768 kHz crystal will take about 80 milliseconds.). Doze mode has faster wake-up time than the STOP mode, at the price of higher current consumption.

The DOZE mode is entered by executing the STOP instruction with the LPM1-0 bits in the IOMCR register set to 10. Refer to 2.4.4.2 Entering the STOP/ DOZE/ STAND_BY Mode for an example instruction sequence for use with the STOP instruction.

2.4.4.1.3 STAND_BY Mode. In STAND_BY mode, the oscillator is active, and the IMP PLL, if enabled, is active but the IMP clock is not active and the IMP is shut down. Current con-

sumption in STAND-BY mode is less than less than 5mA. The wake up time is a few IMP system clock cycles.

The STAND_BY mode is entered by executing the STOP instruction with the LPM1–0 bits in the IOMCR register set to 01. Refer to 2.4.4.2.2 Entering the STOP/ DOZE/ STAND_BY Mode for an example instruction sequence for use with the STOP instruction.

2.4.4.1.4 SLOW_GO Mode. In the SLOW-GO mode, the IMP is fully operational but the IMP PLL divider has been programmed with a value that is dividing the IMP PLL VCO output to the system clock in order to save power. The PLL output divider can only be used with the IMP PLL enabled. The divider value is programmed in the DF3–0 bits in the IOMCR. The clock may be divided by a power of 2 ($2^0 - 2^{15}$). No functionality is lost in SLOW-GO mode.

2.4.4.1.5 NORMAL Mode. In NORMAL mode the IMP part is fully operational and the system clock from the PLL is not being divided down.

2.4.4.1.6 IMP Operation Mode Control Register (IOMCR). IOMCR is a 8-bit read/ write register used to control the operation modes of the IMP. The WP bit in IOMCR is used as a protect mechanism to prevent erroneous writing of IOMCR.

IOMCR

\$0FA

7	6	5	4	3	2	1	0
IOMWP	DF3	DF2	DF1	DF0	BCD	LPM1	LPM0
RESET: 0	0	0	0	0	0	0	0

Read/Write

IOMWP—IMP Operation Mode Control Write Protect Bit

This bit prevents accidental writing into the IOMCR. After reset, this bit defaults to zero to enable writing. Setting this bit prevents further writing (excluding the first write that sets this bit).

DF 3–0—Divide Factor

The Divide Factor Bits define the divide factor of the low power divider of the PLL. These bits specify a divide range between 2^0 and 2^{15} . Changing the value of these bits will not cause a loss of lock condition to the IMP PLL.

BCD—BRG Clock Divide Control

This bit controls whether the divide-by-two block shown in Figure 2-2 is enabled.

- 0 = The BRG clock is divided by 1.
- 1 = The BRG clock is divided by 2.

LPM—Low Power Modes

When the 68000 core executes the STOP instruction, the IMP will enter the specified mode.

LPM1–0:

- 00 = Normal - the IMP PLL and clock oscillator will continue to operate normally.
- 01 = Stand_by Mode
- 10 = DOZE Mode
- 11 = Stop Mode

2.4.4.1.7 Low Power Drive Control Register (LPDCR). This register controls the state of the IMP’s 68000 address and data buses during the Standby, Doze, and Stop modes. By programming this register it is possible to minimize power consumption due to external pul-lups or pull downs, or floating inputs.

LPDCR BAR+\$82A

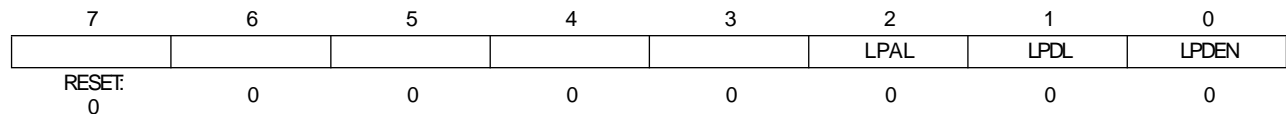

Read/Write

LPDEN—Low Power Drive Enable

- 0 - The IMP 68000 data and address buses will be high impedance.
- 1 - The IMP 68000 data and address buses to be driven according to the LPDL bit.

LPDL—Low Power Drive Data Low

- 0 - The data bus will be driven high when the LPDEN bit is set.
- 1 - The data bus will be driven low when the LPDEN bit is set.

LPAL-Low Power Drive Address Low

- 0 - The address bus will be driven high when the LPDEN bit is set.
- 1 - The address bus will be driven low when the LPDEN bit is set.

2.4.4.1.8 IMP Power Down Register (IPWRD). The IPWRD is a 8-bit read/ write register located at \$0FB that is used to control the low power operation of the IMP. This register must be written with the same operand as the STOP instruction that follows. This tells the hardware what level of interrupt (and above) will stop the MC68LC302 from entering low power if it occurs while the clocks are being stopped.

2.4.4.1.9 Default Operation Modes, See 2.4.2.1 Default System Clock Generation.

2.4.4.2 LOW POWER SUPPORT. The following sections describe how to enter the various low power modes.

2.4.4.2.1 Enter the SLOW_GO mode. When the required IMP performance can be achieved with a lower clock rate, the user can reduce power consumption by dividing IMP

PLL output clock that provides the IMP system clock. Switching between the NORMAL and SLOW_GO modes is achieved by changing the DF3–0 field in the IOMCR register to a non-zero value. The IMP PLL will not lose lock when the DF3–0 field in the IOMCR register is changed.

2.4.4.2.2 Entering the STOP/ DOZE/ STAND_BY Mode. Entering the STOP/ DOZE/ STAND_BY mode is achieved by the 68000 core executing the following code:

```
nop
move.b    *+6(PC),$000000FB    ;copy STOP operand high byte to addr 000000fb
stop     #$xxxx                ;xxxx -> SR
nop
```

This code is position independent. The core must be in the supervisor state to execute the STOP instruction, therefore the write to \$000000FB must be done in the supervisor state (function code 5, supervisor data). The core trace exception should be disabled, otherwise the low power control will not enter the STOP mode.

To guarantee supervisor state and trace exceptions disabled, this code should be part of a TRAP routine. Upon entering the trap routine, examine the stacked status register. If it indicates the supervisor state, then execute this code to enter STOP mode. If not supervisor, do NOT execute this code (could perform some application-specific error):

```
TRAP_x    btst.b    #5,(SP)        ; supervisor?
          beq.s     NO_STOP
          nop        ; flush execution, bus pipes
          move.b    *+6(PC),$000000FB ;copy STOP operand high byte to addr 000000fb
          stop     #$xxxx        ; xxxx -> SR
          nop
          rte
NO_STOP    ...            ; error routine?
```

NOTE

The RI/PB9, DTE/PB10, and periodic interrupt timer timeout interrupts conditions will generate level 4 interrupts. The user should set the 68000 interrupt mask register to the appropriate level before executing this code.

IMP's low power control logic will:

1. Detect the write cycle.
2. Check if bit 5 = 1 (supervisor space) (if it is 0, the low power request will be ignored).
3. Sample the interrupt mask bits (bits 0–2). If during this process of stopping the clocks

an interrupt of higher level than the mask is asserted to the core, this process will abort.

4. Wait for 16 clocks to guarantee the execution of the STOP command by the core. \overline{BG} and \overline{BGACK} will reset the 16-clock counter and it will restart its count.
5. Assert bus request signal to the core.
6. Wait for Bus Grant from the core
7. Force the IMP to the selected power-down mode, as defined in Table 2-3.

2.4.4.2.3 IMP Wake-Up from Low Power STOP Modes. The IMP can wake up from STOP/DOZE/STAND_BY mode to NORMAL/SLOW_GO mode in response to inputs from the following sources:

1. Asserting both \overline{RESET} and \overline{HALT} (hard reset) pins.
2. Asserting (high to low transition) either PB9 or PB10 pins (if these interrupts are enabled).
3. A timeout of the periodic interrupt timer (if the PIT interrupt is enabled).

When one of these events occur (and the corresponding event bit is set), the IMP low power controller will asynchronously restart the IMP clocks. Then IMP low power control logic will release the 68000 bus and the IMP will return to normal operation. If one of the above wake-up events occurs during the execution of the STOP command, the low power control logic will abort the power down sequence and return to normal operation.

NOTE

The RI/PB9, DTE/PB10, and periodic interrupt timer timeout interrupts conditions will generate level 4 interrupts. The user should also set the 68000 interrupt mask in the status register (SR) to the appropriate level before executing the STOP command to ensure that the IMP will wake up to the desired events.

2.4.4.2.4 IMP Wake-Up Control Register (IWUCR). The IWUCR contains control for the wake-up options. This register can be read and written by the 68000 core.

IWUCR							\$0F7
7	6	5	4	3	2	1	0
0	PITE	PB10E	PB9Ev	0	PITEn	PB10En	PB9En
RESET: 0	0	0	0	0	0	0	0

Read/Write

PB9Ev—PB9 Event

This bit will be set to one when there is a high to low transition on the PB9 pin. When PB9En is set and PB9Ev is set, the IMP will wake-up from the selected power down state, and a PB9 Interrupt will be generated. The IMP cannot enter the power-down mode if

PB9Ev and PB9En are both set to one. PB9Ev is cleared by writing a one (writing a zero has no effect).

In modem applications \overline{RI} should be connected to the PB9 pin.

PB10Ev—PB10 Event

This bit will be set to one when there is a high to low transition on the PB10 pin. When PB10En is set and PB10Ev is set, the IMP will wake-up from the selected power down state, and the PB10 Interrupt will be generated. The IMP cannot enter the power-down mode when PB10Ev and PB10En are both set to one. PB10Ev is cleared by writing a one (writing a zero has no effect).

In modem applications the DTE TxD line may be connected to the PB10 pin.

PITEv—PIT Event

This bit will be set to one when there is a time-out on the periodic interrupt timer (PIT). When PITEv bit is set and a time-out occurs (PITEv is set), the IMP will wake-up from the selected power down, and a PIT Interrupt will be generated. The IMP cannot enter the power-down mode if PITEv and PITEv are both set to one. PITEv is cleared by writing a one (writing a zero has no effect).

PB9En—PB9 Enable

This bit, when set, enables the IMP to wake up from power down mode and generate an interrupt when the PB9 Event bit becomes set.

PB10En—PB10 Enable

This bit, when set, enables the IMP to wake up from power down mode and generate an interrupt when the PB10 Event bit becomes set.

PITEv—PIT Enable

This bit, when set, enables the IMP to wake up from power down mode and generate an interrupt when the PIT event bit becomes set, see 3.7.4 Periodic Interrupt Timer (PIT).

2.4.4.3 FAST WAKE-UP

In a system clocked with a 32-kHz oscillator, the wake-up recovery time from doze and stop modes may be too long for some applications. In order to shorten this time, an internal ring oscillator (called Ringo) can clock the chip (the term “real clock” in the following discussion refers to the clock whose source is the external oscillator or crystal; the PLL can be either enabled or disabled). One reason for using the fast wake-up is:

- To allow logic to operate in the time frame between the wake-up command and the actual real clock recovery (from the external crystal or oscillator).

NOTE

If the SCCs use the internal clock, or if they use external clock and the Ringo/external frequency ratio does not comply with the 1 / 2.5 maximum ration specification, then they cannot be enabled until the real clock has resumed operation.

The criteria for enabling Ringo and waking up the CPU (by giving it an interrupt) is: RINGOEN=1 and an unmasked PITEv, PB10Ev, or PB9Ev event occurs (please refer to the IWUCR register)

The internal ring oscillator is not enabled if the PLL is disabled. A system with the PLL disabled has to have an external oscillator connected in order to shorten the wake-up time.

There are two possible interrupts to the CPU from the Ringo logic:

- Interrupt when Ringo is enabled; the CPU is always interrupted when Ringo starts oscillating (RINGOEN bit enables both ring oscillator and enables the interrupt to the CPU). Event bits for this interrupt are all wake-up events.
- Maskable interrupt when the system clock switches to the real clock. The event bit for this interrupt is in the ring oscillator event register.

The Ringo interrupts can be either at level 1, 6, or 7 according to RICR bits. If the CPU determines that the system needs the real clock, it programs the RECLMODE bits which enables the oscillator and PLL and interrupts if necessary; if it decides that the system can go back to sleep, it executes the normal power-down sequence which turns off Ringo. Upon switching to the real clock, the CPU can be interrupted by programming the RICR bits. (Note that Ringo is turned off either at the end of a power down sequence, or when the PLL has gained lock). If the RECLMODE bits are programmed to enable the PLL and the oscillator, the user is allowed to enter low power mode *after* the real clock has resumed. The chip will not operate correctly if the CPU enters the low power sequence while the PLL is waking up. Resetting of the RINGOEN bit is allowed only if the system is clocked by the real clock. The CLKO signal can be disabled by software if the user cannot operate the system at the Ringo frequency.

2.4.4.3.5 Ring Oscillator Control Register (RINGOCR)

RINGOCR							BAR+\$81A
7	6	5	4	3	2	1	0
			RICR		RECLMODE		RINGOEN
RESET:							
0	0	0	0	0	0	0	0

Read/Write

RINGOEN — Ring Oscillator Enable

- 0 = Ring oscillator is not used
- 1 = Ring oscillator is enabled

RECLMODE — Real Clock Mode

- 00 = Do not enable the real clock
- 01 = Enable the real clock and switch the system clock from Ringo to the real clock once it is stable
- 10 = Enable the real clock and generate an interrupt to the CPU after the switch occurs
- 11 = Reserved

RICR — Ring Oscillator Interrupt Control

- 00 = Connect Ringo Interrupts to 68k interrupt request level 1
- 01 = Connect Ringo Interrupts to 68k Interrupt request level 6
- 10 = Connect Ringo Interrupts to 68k interrupt request level 7
- 11 = Reserved

2.4.4.3.6 Ring Oscillator Event Register (RINGOEVR).

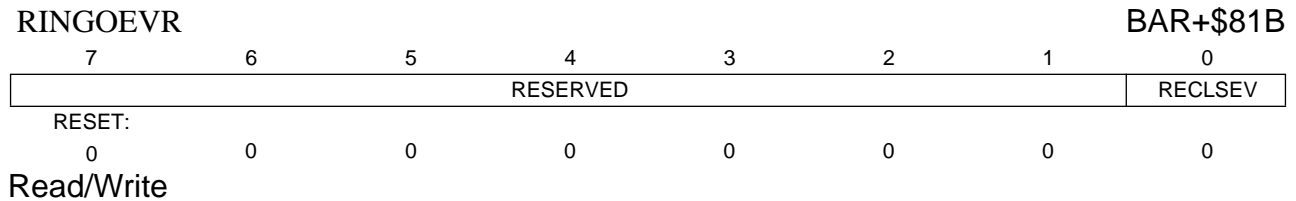

RECLSEV — Real Clock Switch Event

- 0 = Event has not occurred
- 1 = Real clock is now the system clock (This bit is reset by writing 1)

Bits 7-1 — Reserved

2.5 MC68LC302 DUAL PORT RAM

The internal 1152-byte dual-port RAM has 576 bytes of system RAM (see Table 2-4) and 576 bytes of parameter RAM (see Table 2-5).

Table 2-4. System RAM

Address	Width	Block	Description
Base + 000 ⋮ Base + 23F	576 Bytes	RAM	User Data Memory
Base +240 ⋮ Base + 3FF			Reserved (Not Implemented)

The parameter RAM contains the buffer descriptors for each of the two SCC channels, the SCP, and the two SMC channels. The memory structures of the three SCC channels are identical. When any SCC, SCP, or SMC channel buffer descriptors or parameters are not used, their parameter RAM area can be used for additional memory. For detailed information about the use of the buffer descriptors and protocol parameters in a specific protocol, see Section 4 Communications Processor (CP). CP. Base + 67E contains the MC68LC302 revision number.

Table 2-5. Parameter RAM

Address	Width	Block	Description
Base + 400	4 Word	SCC1	Rx BD 0
Base + 408	4 Word	SCC1	Rx BD 1
Base + 410	4 Word	SCC1	Rx BD 2
Base + 418	4 Word	SCC1	Rx BD 3
Base + 420	4 Word	SCC1	Rx BD 4
Base + 428	4 Word	SCC1	Rx BD 5
Base + 430	4 Word	SCC1	Rx BD 6
Base + 438	4 Word	SCC1	Rx BD 7
Base + 440	4 Word	SCC1	Tx BD 0
Base + 448	4 Word	SCC1	Tx BD 1
Base + 450	4 Word	SCC1	Tx BD 2
Base + 458	4 Word	SCC1	Tx BD 3
Base + 460	4 Word	SCC1	Tx BD 4
Base + 468	4 Word	SCC1	Tx BD 5
Base + 470	4 Word	SCC1	Tx BD 6
Base + 478	4 Word	SCC1	Tx BD 7
Base + 480 • • • Base + 4BF		SCC1 SCC1	Specific Protocol Parameters
Base + 4C0 • • Base + 4FF			Reserved (Not Implemented)
Base + 500	4 Word	SCC2	Rx BD 0
Base + 508	4 Word	SCC2	Rx BD 1
Base + 510	4 Word	SCC2	Rx BD 2
Base + 518	4 Word	SCC2	Rx BD 3
Base + 520	4 Word	SCC2	Rx BD 4
Base + 528	4 Word	SCC2	Rx BD 5
Base + 530	4 Word	SCC2	Rx BD 6
Base + 538	4 Word	SCC2	Rx BD 7
Base + 540	4 Word	SCC2	Tx BD 0
Base + 548	4 Word	SCC2	Tx BD 1
Base + 550	4 Word	SCC2	Tx BD 2
Base + 558	4 Word	SCC2	Tx BD 3
Base + 560	4 Word	SCC2	Tx BD 4
Base + 568	4 Word	SCC2	Tx BD 5
Base + 570	4 Word	SCC2	Tx BD 6/DRAM Refresh
Base + 578	4 Word	SCC2	Tx BD 7/DRAM Refresh
Base + 580 • • • Base + 5BF		SCC2 SCC2	Specific Protocol Parameters
Base + 5C0 • • Base + 5FF			Reserved (Not Implemented)
Base + 600 • • Base + 65F	48 Words		Not Used by CP (Available to User)
Base + 660	3 Word	SMC	Reserved
Base + 666	Word	SMC1	Rx BD
Base + 668	Word	SMC1	Tx BD
Base + 66A	Word	SMC2	Rx BD
Base + 66C	Word	SMC2	Tx BD
Base + 66E #	6 Word	SMC1–SMC2	Internal Use
Base + 67A	Word	SCP	Rx/Tx BD
Base + 67C	Word	SCC1–SCC3	BERR Channel Number
Base + 67E #	Word	CP	MC68PM302 Revision Number
Base + 680 • • • Base + 6BF			Reserved
Base + 6C0 • • Base + 7FF			Reserved (Not Implemented)

Modified by the CP after a CP or system reset.

In addition to the internal dual-port RAM, a number of internal registers support the functions of the various M68000 core peripherals. The internal registers (see Table 2-6) are memory-mapped registers offset from the BAR pointer and are located on the internal M68000 bus.

NOTE

All undefined and reserved bits within registers and parameter RAM values written by the user in a given application should be written with zero to allow for future enhancements to the device.

2.6 INTERNAL REGISTERS MAP

Table 2-6. Internal Registers Map

Address	Name	Width	Block	Description	Reset Value
Base + 800	RES	16	IDMA	Reserved	
Base + 802	CMR	16	IDMA	Channel Mode Register	0000 0000
Base + 804	SAPR	32	IDMA	Source Address Pointer	XXXX XXXX
Base + 808	DAPR	32	IDMA	Destination Address Pointer	XXXX
Base + 80C	BCR	16	IDMA	Byte Count Register	00
Base + 80E *	CSR	8	IDMA	Channel Status Register	
Base + 80F	RES	8	IDMA	Reserved	
Base + 810	FCR	8	IDMA	Function Code Register	XX
Base + 811	RES	8	IDMA	Reserved	
Base + 812 #	GIMR	16	Int Cont	Global Interrupt Mode Register	0000
Base + 814 *	IPR	16	Int Cont	Interrupt Pending Register	0000
Base + 816	IMR	16	Int Cont	Interrupt Mask Register	0000
Base + 818 *	ISR	16	Int Cont	In-Service Register	0000
Base + 81A	RINGOCR	8	Int Cont	Ring Oscillator Control Register	00
Base + 81B	RINGOEVR	8	Int Cont	Ring Oscillator Event Register	00
Base + 81C	RES	16	Int Cont	Reserved	
Base + 81E #	PACNT	16	PIO	Port A Control Register	0000
Base + 820 #	PADDR	16	PIO	Port A Data Direction Register	0000
Base + 822 #	PADAT	16	PIO	Port A Data Register	XXXX ##
Base + 824 #	PBCNT	16	PIO	Port B Control Register	0080
Base + 826 #	PBDDR	16	PIO	Port B Data Direction Register	0000
Base + 828 #	PBDAT	16	PIO	Port B Data Register	XXXX ##
Base + 82A	LPDCR	8	PIO	Low Power Drive Control Register	00
Base + 82C	BSR	8	CS	Bus Switch register	0000
Base + 82E	RES	16	CS	Reserved	
Base + 830 #	BR0	16	CS0	Base Register 0	C001
Base + 832 #	OR0	16	CS0	Option Register 0	DFFD
Base + 834 #	BR1	16	CS1	Base Register 1	C000
Base + 836 #	OR1	16	CS1	Option Register 1	DFFD
Base + 838 #	BR2	16	CS2	Base Register 2	C000
Base + 83A #	OR2	16	CS2	Option Register 2	DFFD
Base + 83C #	BR3	16	CS3	Base Register 3	C000
Base + 83E #	OR3	16	CS3	Option Register 3	DFFD
Base + 840	TMR1	16	Timer	Timer Unit 1 Mode Register	0000
Base + 842	TRR1	16	Timer	Timer Unit 1 Reference Register	FFFF
Base + 844	TCR1	16	Timer	Timer Unit 1 Capture Register	0000
Base + 846	TCN1	16	Timer	Timer Unit 1 Counter	0000
Base + 848	RES	8	Timer	Reserved	
Base + 849 *	TER1	8	Timer	Timer Unit 1 Event Register	00
Base + 84A	WRR	16	WD	Watchdog Reference Register	FFFF
Base + 84C	WCN	16	WD	Watchdog Counter	0000
Base + 84E	RES	16	Timer	Reserved	
Base + 850	TMR2	16	Timer	Timer Unit 2 Mode Register	0000
Base + 852	TRR2	16	Timer	Timer Unit 2 Reference Register	FFFF
Base + 854	TCR2	16	Timer	Timer Unit 2 Capture Register	0000
Base + 856	TCN2	16	Timer	Timer Unit 2 Counter	0000
Base + 858	RES	8	Timer	Reserved	

Table 2-6. Internal Registers Map

Address	Name	Width	Block	Description	Reset Value
Base + 859 *	TER2	8	Timer	Timer Unit 2 Event Register	00
Base + 85A	RES	16	Timer	Reserved	
Base + 85C	RES	16	Timer	Reserved	
Base + 85E	RES	16	Timer	Reserved	
Base + 860	CR	8	CP	Command Register	00
Base + 861	Reserved				
Base + 87F					
Base + 880	RES	16	SCC1	Reserved	
Base + 882	SCON1	16	SCC1	SCC1 Configuration Register	0004
Base + 884	SCM1	16	SCC1	SCC1 Mode Register	0000
Base + 886	DSR1	16	SCC1	SCC1 Data Sync. Register	7E7E
Base + 888 *	SCCE1	8	SCC1	SCC1 Event Register	00
Base + 889	RES	8	SCC1	Reserved	
Base + 88A	SCCM1	8	SCC1	SCC1 Mask Register	00
Base + 88B	RES	8	SCC1	Reserved	
Base + 88C	SCCS1	8	SCC1	SCC1 Status Register	00
Base + 88D	RES	8	SCC1	Reserved	
Base + 88E	RES	16	SCC1	Reserved	
Base + 890	RES	16	SCC2	Reserved	
Base + 892	SCON2	16	SCC2	SCC2 Configuration Register	0004
Base + 894	SCM2	16	SCC2	SCC2 Mode Register	0000
Base + 896	DSR2	16	SCC2	SCC2 Data Sync. Register	7E7E
Base + 898 *	SCCE2	16	SCC2	SCC2 Event Register	0000
Base + 899	RES	8	SCC2	Reserved	
Base + 89A	SCCM2	8	SCC2	SCC2 Mask Register	00
Base + 89B	RES	8	SCC2	Reserved	
Base + 89C	SCCS2	8	SCC2	SCC2	0000
Base + 89D	RES	8	SCC2	Reserved	
Base + 89E	RES	16	SCC2	Reserved	
Base + 8A0	Reserved				
Base + 8AE					
Base + 8B0	SPMODE	16	SCM	SCP, SMC Mode and Clock Control Register	0000
Base + 8B2 #	SIMASK	16	SI	Serial Interface Mask Register	FFFF
Base + 8B4 #	SIMODE	16	SI	Serial Interface Mode Register	0000
Base + 8B6	Reserved				
Base + 8DA					
Base + 8DC #	PNDNR	8	PIO	Pin IO Data Direction Register	0000
Base + 8DE #	PNDAT	8	PIO	Pin IO Data Register	0000
Base + 8E0	Reserved				
Base + 8EC					
Base + 8EE #	DISC	16	SIB	Disable SCC1 Serial Clocks	0000
Base + 8F0	Reserved				
Base + FFF					

Reset only upon total system reset. (RESET and HALT assert together), but not on the execution of an M68000 RESET instruction. See the RESET pin description for details.

The output latches are undefined at total system reset.

* Event register with special properties.

SECTION 3

SYSTEM INTEGRATION BLOCK (SIB)

The MC68LC302 contains an extensive SIB that simplifies the job of both the hardware and software designer. Most of the features are taken from the MC68302 without change, features that have been added are highlighted in **bold** text.

NOTE

This section will only present the register descriptions for each block. For more information on the operation of each block, please refer to the *MC68302 Users' Manual*. Items that are new or have changed will be described in detail.

The SIB includes the following functions:

- IDMA Controller
- Interrupt Controller with Two Modes of Operation
- Parallel Input/Output (I/O) Ports, Some with Interrupt Capability
- **Parallel Input/Output Ports on D15-D8 in 8 bit mode**
- On-Chip 1152-Byte Dual-Port RAM
- Four Timers Including a Watchdog Timer and **Periodic Interrupt Timer**
- Four Programmable Chip-Select Lines with Wait-State Generator Logic
- **Glueless Interface to SRAM, EPROM, Flash EPROM, and EEPROM**
- System Control
 - System Status and Control Logic
 - Disable CPU Logic (M68000)
 - Bus Arbitration Logic with Low-Interrupt Latency Support (for internal DMA)
 - Hardware Watchdog for Monitoring Bus Activity
 - DRAM Refresh Controller
 - Programmable Bus Width
- **Boot from SCC**

3.1 SYSTEM CONTROL

The IMP system functions are configured using the System Control Register (SCR). The following systems are configured:

- System Status and Control Logic

- \overline{AS} Control During Read-Modify-Write-Cycles
- Disable CPU (M68000) Logic
- Bus Arbitration Logic with Low-Interrupt Latency Support (**Disable CPU only**)
- Hardware Watchdog
- Low-Power (Standby) Modes
- Freeze Control (**Only supported in the PGA package**)

3.1.1 System Control Register (SCR)

The SCR is a 32-bit register that consists of system status, control bits, a bus arbiter control bit, and hardware watchdog control bits. Refer to Figure 3-1 and to the following paragraphs for a description of each bit in this register. The SCR is a memory-mapped read-write register. The address of this register is fixed at \$0F4 in supervisor data space (FC = 5).

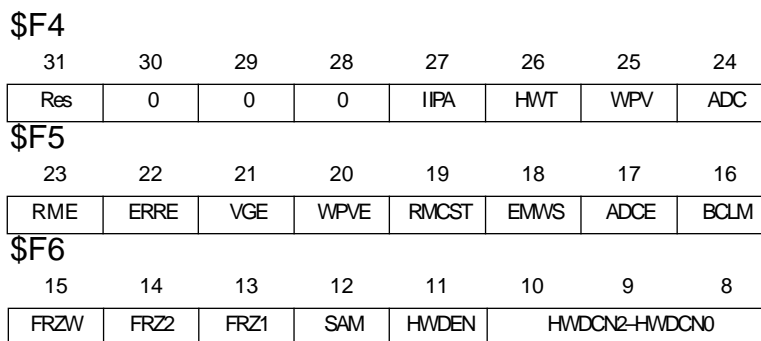

Figure 3-1. System Control Register

Table 3-1. SCR Register Bits

Bit	Name
IPA	Interrupt Priority Active
HWT	Hardware Watchdog Timeout
WPV	Write Protect Violation
ADC	Address Decode Conflict
RME	Ram Microcode Enable
ERRE	External RISC Request Enable
VGE	Vector Generation Enable
WPVE	Write Protect Violation Enable
RMCST	Read-Modify-Write Cycle Special Treatment
EMWS	External Master Wait State
ADCE	Address Decode Conflict Enable
BCLM	Bus Clear Mask
FRZW	Freeze Watch Dog Timer Enable
FRZ1	Freeze Timer 1 Enable
FRZ2	Freeze Timer 2 Enable
SAM	Synchronous Access Mode
HWDEN	Hardware Watchdog Enable
HWDCN	Hardware Watchdog Count

3.1.2 System Status Bits

Bits 27-24 of the SCR are used to report events recognized by the system control logic. On recognition of an event, this logic sets the corresponding bit in the SCR. These bits may be read at any time. A bit is reset by a one and is left unchanged by a zero. More than one bit may be reset at a time. For more information on these bits, please refer to the *MC68302 User's Manual*.

After system reset (simultaneous assertion of $\overline{\text{RESET}}$ and $\overline{\text{HALT}}$), these bits are cleared.

IPA—Interrupt Priority Active

This bit is set when the M68000 core has an unmasked interrupt request.

NOTE

If BCLM is set, an interrupt handler will normally clear IPA at the end of the interrupt routine to allow an alternate bus master to regain the bus; however, if BCLM is cleared, no additional action needs to be taken in the interrupt handler.

HWT—Hardware Watchdog Timeout

This bit is set when the hardware watchdog (see 3.1.5 Hardware Watchdog) reaches the end of its time interval; an internal $\overline{\text{BERR}}$ is generated following the watchdog timeout, even if this bit is already set.

WPV—Write Protect Violation

This bit is set when a bus master attempts to write to a location that has RW set to zero (read only) in its associated base register (BR3–BR0).

ADC—Address Decode Conflict

This bit is set when a conflict has occurred in the chip-select logic because two or more chip-select lines attempt assertion in the same bus cycle.

3.1.3 System Control Bits

The system control logic uses six control bits in the SCR.

WPVE—Write Protect Violation Enable

0 = an internal $\overline{\text{BERR}}$ is not asserted when a write protect violation occurs.

1 = an internal $\overline{\text{BERR}}$ is asserted when a write protect violation occurs.

After system reset, this bit defaults to zero.

NOTE

WPV will be set regardless of the value of WPVE.

RMCST—RMC Cycle Special Treatment

0 = The locked read-modify-write cycles of the TAS instruction will be identical to the M68000 ($\overline{\text{AS}}$ and $\overline{\text{CS}}$ will be asserted during the entire cycle). The arbiter will issue

\overline{BG} , regardless of the M68000 core \overline{RMC} . If an IMP chip select is used then the \overline{DTACK} generator will insert wait states on the read cycle only.

- 1 = The IMP uses the internal \overline{RMC} to negate \overline{AS} and \overline{CS} at the end of the read portion of the RMC cycle and reasserts \overline{AS} and \overline{CS} at the beginning of the write portion. \overline{BG} will not be asserted until the end of the write portion. If an IMP chip select is used, the \overline{DTACK} generator will insert wait states on both the read and write portion of the cycles.

The assertion of the internal \overline{RMC} by the M68000 core is seen by the arbiter and will prevent the arbiter from issuing bus grants until the completion of M68000-initiated locked read-modify-write activity. After system reset, this bit defaults to zero.

EMWS—External Master Wait State (EMWS) (VALID only in Disable CPU Mode)

When EMWS is set and an external master is using the chip-select logic for \overline{DTACK} generation or is synchronously reading from the internal peripherals ($SAM = 1$), one additional wait state will be inserted in every memory cycle to external memory, peripherals, and also, in every cycle to internal memory and peripherals. When EMWS is cleared, all synchronous internal accesses will be with zero wait states and the chip-select logic will generate \overline{DTACK} after the exact programmed number of wait states. The chip-select lines are asserted slightly earlier for internal master memory cycles than for an external master. EMWS should be set whenever these timing differences will necessitate an additional wait state for external masters. After system reset, this bit defaults to zero.

ADCE—Address Decode Conflict Enable

- 0 = an internal \overline{BERR} is not asserted by a conflict in the chip-select logic when two or more chip-select lines are programmed to overlap the same area.
- 1 = an internal \overline{BERR} is asserted by a conflict in the chip-select logic when two or more chip-select lines are programmed to overlap the same area.

BCLM—Bus Clear Mask

- 0 = The arbiter does not use the M68000 core internal IPEND signal to assert the internal bus clear signals.
- 1 = The arbiter uses the M68000 core internal IPEND signal to assert the internal bus clear signals.

SAM—Synchronous Access Mode (Valid only in Disable CPU Mode)

This bit controls how external masters may access the IMP peripheral area. This bit is not relevant for applications that do not have external bus masters that access the IMP. In applications such as disable CPU mode, in which the M68000 core is not operating, the user should note that SAM may be changed by an external master on the first access of the IMP, but that first write access must be asynchronous with three wait states. (If \overline{DTACK} is used to terminate bus cycles, this change need not influence hardware.)

- 0 = Asynchronous accesses. All accesses to the IMP internal RAM and registers (including BAR and SCR) by an external master are asynchronous to the IMP clock. Read and write accesses are with three wait states, and \overline{DTACK} is asserted by the IMP assuming three wait-state accesses. This is the default value.

- 1 = Synchronous accesses. All accesses to the IMP internal RAM and registers (including BAR and SCR) must be synchronous to the IMP clock. Synchronous read accesses may occur with one wait state if EMWS is also set to one.

RME—Ram Microcode Enable

This bit is used to initiate the execution of Communication Processor microcode that has been loaded into the dual port RAM. See Appendix C in MC68302UM/AD.

VGE—Vector Generation Enable (**Not supported by the MC68LC302**)

This bit must be written to zero. Since the MC68LC302 cannot decode an interrupt acknowledge cycle from an external processor without the FC pins, the user should provide either an autovector signal or a vector back to the host processor during an interrupt acknowledge cycle for the MC68LC302. The user should then read the IPR to determine which the interrupt source.

3.1.4 Freeze Control

Used to freeze the activity of selected peripherals, FRZ is useful for system debugging purposes (For more information on these bits, please refer to the *MC68302 Users' Manual*):

FRZ1 — Freeze Timer 1 Enable

- 0 = Freeze Timer 1 Logic is disabled
- 1 = Freeze Timer 1 Logic is enabled

After system reset this bit defaults to zero.

FRZ2 — Freeze Timer 2 Enable

- 0 = Freeze Timer 2 Logic is disabled
- 1 = Freeze Timer 2 Logic is enabled

After system reset this bit defaults to zero.

FRZW — Freeze Watchdog Timer Enable

- 0 = Freeze Watchdog Timer Logic is disabled
- 1 = Freeze Watchdog Timer Logic is enabled

After system reset this bit defaults to zero.

3.1.5 Hardware Watchdog

The hardware watchdog logic is used to assert an internal $\overline{\text{BERR}}$ and set HWT when a bus cycle is not terminated by $\overline{\text{DTACK}}$ and after a programmable number of clock cycles has elapsed. The hardware watchdog logic uses four bits in the SCR.

HW DEN—Hardware Watchdog Enable

- 0 = The hardware watchdog is disabled.
- 1 = The hardware watchdog is enabled.

After system reset, this bit defaults to one to enable the hardware watchdog.

HWDCN—HWDCN0—Hardware Watchdog Count 2–0

- 000 = an internal $\overline{\text{BERR}}$ is asserted after 128 clock cycles (8 μs , 16-MHz clock)
- 001 = an internal $\overline{\text{BERR}}$ is asserted after 256 clock cycles (16 μs , 16-MHz clock)
- 010 = an internal $\overline{\text{BERR}}$ is asserted after 512 clock cycles (32 μs , 16-MHz clock)
- 011 = an internal $\overline{\text{BERR}}$ is asserted after 1K clock cycles (64 μs , 16-MHz clock)
- 100 = an internal $\overline{\text{BERR}}$ is asserted after 2K clock cycles (128 μs , 16-MHz clock)
- 101 = an internal $\overline{\text{BERR}}$ is asserted after 4K clock cycles (256 μs , 16-MHz clock)
- 110 = an internal $\overline{\text{BERR}}$ is asserted after 8K clock cycles (512 μs , 16-MHz clock)
- 111 = an internal $\overline{\text{BERR}}$ is asserted after 16K clock cycles (1 ms, 16-MHz clock)

3.2 PROGRAMMABLE DATA BUS SIZE SWITCH

The following procedure allows 68LC302 to be booted in an 8 or 16 bit bus width and then switched to 16 or 8 bit bus width for future accesses. It does not implement true dynamic bus sizing, but allows a software reconfiguration of the BUSW pin.

3.2.1 Bus Switch Register (BSR)

BSR			Base +\$82C	
7	6	5	4	3-0
0	BSW	BSWEN	0	0
0	0	0	0	0

BWSEN - Bus Width Switch Enable

When this bit is toggled from a zero to a one, the bus width switch mechanism is enabled. From the point this bit is toggled, the bus width is determined by the BSW bit of this register. If another bus width switch is necessary, this bit must be toggled back to zero and then one again.

Setting this bit implements a hardware state machine that arbitrates the internal bus away from the 302 core, changes the BUSW pin internally, and then gives the bus back to the 302 core.

BUSW - Bus Width

This bit determines the bus width after the bus width switch is performed.

- 0 - Data bus width is 8 bits
- 1 - Data bus width is 16 bits.

3.2.2 Basic Procedure:

The MC68LC302 is booted in its 8-bit mode by externally connecting the BUSW pin to GND. It is expected that the MC68LC302 will be executing out of EPROM or flash at this time, and that no external data memory is available in 8-bit mode.

The MC68LC302 initializes the BAR register to place the 4K block of dual-port RAM and peripherals in an area that does not overlap the EPROM region. Note that this is part of a normal 302 initialization sequence. Also note that the CFC bit of the BAR register should NOT be set -- it must be cleared.

At this time other desired initialization should be completed on the MC68LC302. No bus masters (IDMA, SDMA, or external) should be enabled.

While in 8-bit mode, the MC68LC302 should initialize the external memory registers that control the 16-bit external memory space. External memory refresh is not enabled at this time, but all other desired external memory control features should be enabled. Note that the MC68LC302 does not access the external memory itself yet, only the external memory control registers.

The 302-based device now copies a special boot code to the user area of the internal dual-port RAM of the 302, and then jumps to the start of that code. This code is copied as “data” to the dual-port RAM.

To summarize, the procedure is then:

- Boot up 302-derivative
- Perform required 8 bit operations
- Write code to the dual port RAM for the bus width change
- Jump to code in the dual port RAM
- When ready to use 16-bit bus width, set the BUSW bit to 1
- Toggle the BWSEN bit from zero to one.
- Allow time for bus arbitration and the instruction pipeline to clear
- Initialize external memory
- Copy boot code from EPROM to external memory space
- Execute code from external memory space

NOTE

The stack which is shared by both codes should be placed in the dual ported RAM. Copy the stack to dual port RAM after switching to the second RAM and change the stack pointer.

3.3 LOAD BOOT CODE FROM AN SCC

The MC68LC302 provides the capability of downloading program code into SCC1 and beginning program execution in the dual port RAM. The boot function has two clocking options: external and internal.

In the first mode, the user provides the chip with an external clock 16* the desired baud rate. In the second mode, the RISC processor programs the SCC into UART mode running at approximately 9600 baud (assuming the frequency of the clock to the chip has one of two nominal values 32.768 Khz or 4.192 Mhz).

The first 576 bytes that are received into SCC1 are stored in the dual-port RAM. No error checking is performed on the incoming serial bit stream. The 68000 processor then begins

executing from the first location of the dual-port RAM to complete the boot process. This function is not supported for SCC2.

Three pins are sampled to determine the mode of operation and clock of the boot function:

PA7—Sampled during Hard Reset ($\overline{\text{RESET}}$ and $\overline{\text{HALT}}$ asserted)

- 0 Boot from SCC is enabled
- 1 Boot from SCC is disabled

PA5—Sampled within 100 clocks from the negation of $\overline{\text{RESET}}$

- 0 Internal Clock
- 1 External Clock 16* the bit rate on TCLK1 and RCLK1

PA12 (MODCLK0) Sampled during Hard Reset ($\overline{\text{RESET}}$ and $\overline{\text{HALT}}$ asserted)

- 0 Nominal input frequency on EXTAL is 4.192 Mhz
- 1 Nominal input frequency on EXTAL is 32.768 Khz

To enable the boot function, the PA7 pin must be pulled low during system reset. (System reset is defined by the $\overline{\text{RESET}}$ and $\overline{\text{HALT}}$ pins being asserted.) The PA7 pin must be pulled high during system reset, if boot mode is not to be enabled. Once the MC68LC302 detects that the PA7 pin is asserted, it internally keeps the $\overline{\text{HALT}}$ signal to the 68K core asserted after system reset is complete. This action prevents the 68000 from fetching the reset vector.

NOTE

PA7 needs to be either pulled UP or pulled DOWN. Do not leave this pin floating during reset.

Once system reset is complete, the RISC processor programs the BAR register to \$0000 to place the dual-port RAM at the low end of system memory. It then samples the PA5 pin to determine the clock source for the UART.

NOTE

PA5 is expected to be valid for 100 clocks after the negation of $\overline{\text{RESET}}$.

If PA5 is pulled high, SCC1 is programmed for external clocks. In this mode, the user has to connect an external clock 16* the bit rate to TCLK1 and RCLK1.

If PA5 is pulled low, the SCC is programmed for internal clocks and the TCLK1 and RCLK1 pins are programmed to three-state to avoid contention with user clocks. The RISC processor then programs the SCON register of the SCC based on PA12. The PA12 value sampled during reset (MODCLK0) is decoded in order to provide ~9600 bps with two input frequencies (4.192 Mhz and 32.768 Khz).

- If MODCLK0 = GND, SCON1 is programmed to 0x00D8.

- If MODCLK0 = VCC, SCON1 is programmed to 0x00A8.

The following baud rates are achieved as a function of VCCSYN, MODCLK, and input clock:

VCCSYN-MODCLK

00	20 Mhz	11467 bps (SCON1=0x00D8)
10	4.192 Mhz	9614 bps (SCON1=0x00D8)
10	4.8 Mhz	11009 bps (SCON1=0x00D8)
11	32.768 Khz	9662 bps (SCON1=0x00A8)

The following paragraphs explain the boot process for the 32.768 Khz case in detail. If the clock provided to the MC68LC302 is 32.768 KHz, the system frequency is multiplied by 401 to get 13.139968 MHz. The CD10-CD0 bits of the SCON are programmed to 84 decimal giving a UART frequency of 9662. In summary, $13.139968 \text{ MHz} / (84 + 1) / 16 = 9662$. If the starting frequency is exactly 32.000 KHz, the UART frequency is 9435.

NOTE

The autobaud function cannot be used in the boot download process.

Values in bit CD10:0 in SCON are not relevant if PA5=1

The RISC processor then programs the SCM register to \$013D to program the SCC to UART mode with both the receiver and the transmitter enabled, software operation mode ($\overline{\text{CD}}$ and $\overline{\text{CTS}}$ are don't cares), 8-bit data characters, and no parity. The RISC processor then begins receiving data into the dual-port RAM beginning with location \$0 of the dual-port RAM. Every character that is received is "echoed" back out of the TXD1 pin. The MC68LC302 UART must be sent 576 bytes of data from the external UART since the LC302 will not leave the boot mode until 576 bytes are received. If the boot program is less than 576 bytes, the user is suggested to write \$00 into the remaining locations.

After 576 bytes are received, the RISC programs the SCM register to \$0, which clears the ENR and ENT bits to disable the UART (returns to its reset value).

The RISC processor next negates the $\overline{\text{HALT}}$ signal to the core internally. The 68000 then reads the reset vector from the first location of the dual-port RAM. In most cases, the code that is downloaded will enable the chip selects of the MC68LC302, initialize the MC68LC302 receive buffer descriptors of SCC1 to continue receiving additional boot code into external system RAM, and re-initialize the UART receiver.

NOTE

The first 576 bytes also overlays the exception vector table, meaning that exception vectors will not work unless the user carefully maps the code around certain desired vectors and points those vectors into the 576 byte code space. In addition

the stack pointer must point into the 576 bytes if any exceptions are to be taken within the boot code.

All 68000 accesses to the dual port RAM are visible externally on the address and data pins so program execution in the 576 byte code space can be monitored.

After the boot process is completed by the user, it is suggested that the user issue the CP Reset command to the CP command register (CR) before reinitializing the SCCs. This will return the CP to its original state and eliminate any possible inconsistencies in the initialization process. The RISC cannot return to boot mode unless a system reset is executed with the PA7 pin asserted low. Toggling of the PA7 pin when the device is not in system reset is allowed, and in this mode the PA7 pin can be used in its alternate functions.

NOTE

The user may wish to disable the software watchdog timer (Timer 3) in the initial boot code if a long delay (i.e. more than 10 seconds) can occur between the initial boot download and the rest of the download process.

At the end of the Boot from SCC function, the following registers contain values that differ from their default reset values:

ICR = 0xc000
BAR = 0x0000
SCON1 = depends on mode.

The SCM1 register is reprogrammed to its reset value of 0x0

NOTE

During the Boot from SCC procedure no external master should acquire the bus.

3.4 DMA CONTROL

The IMP includes seven on-chip DMA channels, six serial DMA (SDMA) channels for the three serial communications controllers (SCCs) and one IDMA. The SDMA channels are discussed in the *MC68302 User's Manual*. The IDMA is discussed in the following paragraphs.

3.4.1 MC68LC302 Differences

The $\overline{\text{DREQ}}$, $\overline{\text{DACK}}$, and $\overline{\text{DONE}}$ pins have been removed. The user must not program the IDMA for external request generation.

The External Bus Exceptions, $\overline{\text{BERR}}$ and Retry, have been removed. Only $\overline{\text{HALT}}$ or an internal $\overline{\text{BERR}}$ generated by the Hardware Watchdog Timer is supported.

The rest of the functionality remains the same as for the MC68302. For details on the bus operation, please refer to the MC68302 User's Manual.

3.4.2 IDMA Registers (Independent DMA Controller)

The IDMA has six registers that define its specific operation. These registers include a 32-bit source address pointer register (SAPR), a 32-bit destination address pointer register (DAPR), an 8-bit function code register (FCR), a 16-bit byte count register (BCR), a 16-bit channel mode register (CMR), and an 8-bit channel status register (CSR).

3.4.2.1 Channel Mode Register (CMR)

The CMR, a 16-bit register, is reset to \$0000.

15	14	13	12	11	10	9	8	7	6	5	4	3	2	1	0
—	ECO	INTN	INTE	REQG		SAPI	DAPI	SSIZE		DSIZE		BT	RST	STR	

Bit 15—Reserved for future use.

ECO—External Control Option (**NOT USED**)

- 0 = If the request generation is programmed to be external in the REQG bits, the control signals (\overline{DACK} and \overline{DONE}) are used in the source (read) portion of the transfer since the peripheral is the source.
- 1 = If the request generation is programmed to be external in the REQG bits, the control signals (\overline{DACK} and \overline{DONE}) are used in the destination (write) portion of the transfer since the peripheral is the destination.

INTN—Interrupt Normal

- 0 = When the channel has completed an operand transfer without error conditions, the channel does not generate an interrupt request to the IMP interrupt controller. The DONE bit remains set in the CSR.
- 1 = When the channel has completed an operand transfer without error conditions, the channel generates an interrupt request to the IMP interrupt controller and sets DONE in the CSR.

INTE—Interrupt Error (**Only the internal \overline{BERR} signal will be used.**)

- 0 = If a bus error occurs during an operand transfer either on the source read (BES) or the destination write (BED), the channel does not generate an interrupt to the IMP interrupt controller. The appropriate bit remains set in the CSR.
- 1 = If a bus error occurs during an operand transfer either on BES or BED, the channel generates an interrupt to the IMP interrupt controller and sets the appropriate bit (BES or BED) in the CSR.

REQG—Request Generation (**External request is not supported**)

- 00 = Internal request at limited rate (limited burst bandwidth) set by burst transfer (BT) bits
- 01 = Internal request at maximum rate (one burst)
- 10 = External request burst transfer mode (\overline{DREQ} level sensitive)
- 11 = External request cycle steal (\overline{DREQ} edge sensitive)

NOTE

The settings 10 and 11 will not work since the $\overline{\text{DREQ}}$ pin is not present.

SAPI—Source Address Pointer (SAP) Increment

- 0 = SAP is not incremented after each transfer.
- 1 = SAP is incremented by one or two after each transfer, according to the source size (SSIZE) bits and the starting address.

DAPI—Destination Address Pointer (DAP) Increment

- 0 = DAP is not incremented after each transfer.
- 1 = DAP is incremented by one or two after each transfer, according to the destination size (DSIZE) bits and the starting address.

SSIZE—Source Size

- 00 = Reserved
- 01 = Byte
- 10 = Word
- 11 = Reserved

DSIZE—Destination Size

- 00 = Reserved
- 01 = Byte
- 10 = Word
- 11 = Reserved

BT—Burst Transfer

- 00 = IDMA gets up to 75% of the bus bandwidth.
- 01 = IDMA gets up to 50% of the bus bandwidth.
- 10 = IDMA gets up to 25% of the bus bandwidth.
- 11 = IDMA gets up to 12.5% of the bus bandwidth.

RST—Software Reset

- 0 = Normal operation
- 1 = The channel aborts any external pending or running bus cycles and terminates channel operation. Setting RST clears all bits in the CSR and CMR.

STR—Start Operation

- 0 = Stop channel; clearing this bit will cause the IDMA to stop transferring data at the end of the current operand transfer. The IDMA internal state is not altered.
- 1 = Start channel; setting this bit will allow the IDMA to start (or continue if previously stopped) transferring data.

NOTE

STR is cleared automatically when the transfer is complete.

3.4.2.2 Source Address Pointer Register (SAPR)

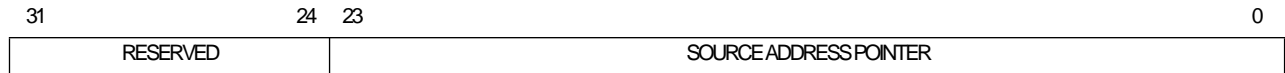

The SAPR is a 32-bit register.

Note that A23-A20 must be initialized by the user. They are driven internally by the IDMA and can be used by the chip selects for address comparison.

3.4.2.3 Destination Address Pointer Register (DAPR)

The DAPR is a 32-bit register.

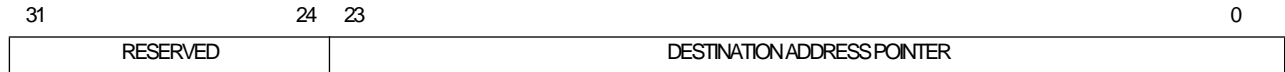

Note that A23-A20 must be initialized by the user. They are driven internally by the IDMA and can be used by the chip selects for address comparison.

3.4.2.4 Function Code Register (FCR)

The FCR is an 8-bit register.

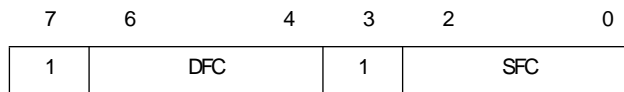

The function codes must be initialized by the user. The function code value programmed into the FCR is driven on the internal FC2-0 signals during a bus cycle to further qualify the address bus value. These values may be used by the chip selects for address matching.

NOTE

This register is undefined following power-on reset. The user should always initialize it and should not use the function code value "111" in this register.

3.4.2.5 Byte Count Register (BCR)

This 16-bit register specifies the amount of data to be transferred by the IDMA; up to 64K bytes (BCR = 0) is permitted.

3.4.2.6 Channel Status Register (CSR)

The CSR is an 8-bit register used to report events recognized by the IDMA controller. On recognition of an event, the IDMA sets its corresponding bit in the CSR (regardless of the INTE and INTN bits in the CMR).

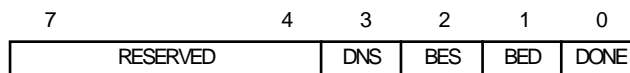

Bits 7–4—These bits are reserved for future use.

DNS—Done Not Synchronized (**NOT USED**)

BES—Bus Error Source

This bit indicates that the IDMA channel terminated with an error during the read cycle.

BED—Bus Error Destination

This bit indicates that the IDMA channel terminated with an error during the write cycle.

DONE—Normal Channel Transfer Done

This bit indicates that the IDMA channel has terminated normally.

3.5 INTERRUPT CONTROLLER

The IMP interrupt controller accepts and prioritizes both internal and external interrupt requests and generates a vector number during the CPU interrupt acknowledge cycle.

3.5.1 Interrupt Controller Key Differences

Since the function code pins are not connected externally, the MC68LC302 (with the core enabled) should be programmed to Dedicated Mode and to internally generate the vectors for Levels 1, 6, and 7. An external device will not be able to decode an IACK cycle and provide an vector back to the MC68LC302.

In Disable CPU mode, the $\overline{IRQ1}$, $\overline{IRQ6}$, and $\overline{IRQ7}$ become the \overline{BR} , \overline{BGACK} , and \overline{BG} signals. With the core disabled, the MC68LC302 will not be able to decode an external CPU's interrupt acknowledge cycle. The user must poll the Interrupt Pending Register (IPR) during interrupt handling to determine which peripheral caused the interrupt.

3.5.2 Interrupt Controller Programming Model

The user communicates with the interrupt controller using four registers. The global interrupt mode register (GIMR) defines the interrupt controller's operational mode. The interrupt pending register (IPR) indicates which INRQ interrupt sources require interrupt service. The interrupt mask register (IMR) allows the user to prevent any of the INRQ interrupt sources from generating an interrupt request. The interrupt in-service register (ISR) provides a capability for nesting INRQ interrupt requests.

3.5.2.1 Global Interrupt Mode Register (GIMR)

The user normally writes the GIMR soon after a total system reset. The GIMR is initially \$0000 and is reset only upon a total system reset.

15	14	13	12	11	10	9	8	7	5	4	0
MOD	I7	I6	I1	—	ET7	ET6	ET1	V7-V5	RESERVED		

MOD—Mode (**The Mode Should be set to Dedicated**)

0 = Normal operational mode. Interrupt request lines are configured as $\overline{IPL2}$ – $\overline{IPL0}$.

1 = Dedicated operational mode. Interrupt request lines are configured as $\overline{IRQ7}$, $\overline{IRQ6}$, and $\overline{IRQ1}$.

IV7—Level 7 Interrupt Vector (Internal Vector Generation Should Be Used)

- 0 = Internal vector.
- 1 = External vector.

IV6—Level 6 Interrupt Vector (Internal Vector Generation Should Be Used)

- 0 = Internal vector.
- 1 = External vector.

IV1—Level 1 Interrupt Vector (Internal Vector Generation Should Be Used)

- 0 = Internal vector.
- 1 = External vector.

ET7— $\overline{\text{IRQ7}}$ Edge-/Level-Triggered

- 0 = Level-triggered. An interrupt is made pending when $\overline{\text{IRQ7}}$ is low.

NOTE

The M68000 always treats level 7 as an edge-sensitive interrupt.

- 1 = Edge-triggered. An interrupt is made pending when $\overline{\text{IRQ7}}$ changes from one to zero (falling edge).

ET6— $\overline{\text{IRQ6}}$ Edge-/Level-Triggered

- 0 = Level-triggered. An interrupt is made pending when $\overline{\text{IRQ6}}$ is low.
- 1 = Edge-triggered. An interrupt is made pending when $\overline{\text{IRQ6}}$ changes from one to zero (falling edge).

ET1— $\overline{\text{IRQ1}}$ Edge-/Level-Triggered

- 0 = Level-triggered. An interrupt is made pending when $\overline{\text{IRQ1}}$ is low.
- 1 = Edge-triggered. An interrupt is made pending when $\overline{\text{IRQ1}}$ changes from one to zero (falling edge).

V7–V5—Interrupt Vector Bits 7–5

These three bits are concatenated with five bits provided by the interrupt controller, which indicate the specific interrupt source, to form an 8-bit interrupt vector number. If these bits are not written, the vector \$0F is provided.

NOTE:

These three bits should be greater than or equal to '010' in order to put the interrupt vector in the area of the exception vector table for user vectors.

Bits 11 and 4–0—Reserved for future use.

3.5.2.2 Interrupt Pending Register (IPR)

Each bit in the 16-bit IPR corresponds to an INRQ interrupt source. When an INRQ interrupt is received, the interrupt controller sets the corresponding bit in the IPR.

NOTE

The ERR bit is set if the user drives the $\overline{IPL2}$ – $\overline{IPL0}$ lines to interrupt level 4 and no INRQ interrupt is pending.

15	14	13	12	11	10	9	8
PB11	PB10	SCC1	SDMA	IDMA	SCC2	TIMER1	—
7	6	5	4	3	2	1	0
PB9	TIMER2	SCP	TIMER3	SMC1	SMC2	PB8	ERR

3.5.2.3 Interrupt Mask Register (IMR)

Each bit in the 16-bit IMR corresponds to an INRQ interrupt source. The user masks an interrupt source by clearing the corresponding bit in the IMR.

15	14	13	12	11	10	9	8
PB11	PB10	SCC1	SDMA	IDMA	SCC2	TIMER1	—
7	6	5	4	3	2	1	0
PB9	TIMER2	SCP	TIMER3	SMC1	SMC2	PB8	—

3.5.2.4 Interrupt In-Service Register (ISR)

Each bit in the 16-bit ISR corresponds to an INRQ interrupt source. In a vectored interrupt environment, the interrupt controller sets the ISR bit when the vector number corresponding to the INRQ interrupt source is passed to the core during an interrupt acknowledge cycle. The user's interrupt service routine should clear this bit during the servicing of the interrupt.

15	14	13	12	11	10	9	8
PB11	PB10	SCC1	SDMA	IDMA	SCC2	TIMER1	0
7	6	5	4	3	2	1	0
PB9	TIMER2	SCP	TIMER3	SMC1	SMC2	PB8	0

3.6 PARALLEL I/O PORTS

The IMP supports three general-purpose I/O ports, port A, port B, and port N, whose pins can be general-purpose I/O pins or dedicated peripheral interface pins. Some port B pins are always maintained as four general-purpose I/O pins, each with interrupt capability.

3.6.1 PARALLEL I/O PORT DIFFERENCES

The following port pins were removed: PA11, PA13, PA14, PA15, PB0, PB1, PB2, and PB4. If these signals are programmed to be inputs, the corresponding values in the data registers will be indeterminate. If these pins are programmed to be output, then the output value will be read back in the data register.

The SCP pins are now multiplexed onto PA8, PA9, and PA10.

The MODCLK pin is multiplexed with the PA12 port pin. After reset, this pin becomes a general purpose I/O pin.

An 8-bit port, Port N, has been added. Port N is only available when the MC68LC302 is in 8-bit mode (internal BUSW=0).

3.6.2 Port A

Each of the port A pins are independently configured as a general-purpose I/O pin if the corresponding port A control register (PACNT) bit is cleared. Port A pins are configured as dedicated on-chip peripheral pins if the corresponding PACNT bit is set. When acting as a general-purpose I/O pin, the signal direction for that pin is determined by the corresponding control bit in the port A data direction register (PADDR). The port I/O pin is configured as an input if the corresponding PADDR bit is cleared; it is configured as an output if the corresponding PADDR bit is set. The PADAT register is used to read and write values for the Port A pins. All PACNT bits and PADDR bits are cleared on total system reset, configuring all port A pins as general-purpose input pins.

Table 3-2. Port A Pin Functions

PACNT Bit = 1 Pin Function	PACNT Bit = 0 Pin Function	Input to SCC2/SCC3/IDMA
RXD2	PA0	GND
TXD2	PA1	—
RCLK2	PA2	GND
TCLK2	PA3	RCLK2 #
$\overline{\text{CTS2}}$	PA4	GND
$\overline{\text{RTS2}}$	PA5	—
$\overline{\text{CD2}}$	PA6	GND
SDS2/BRG2	PA7	—
SPRXD	PA8	GND
SPTXD	PA9	—
SPCLK	PA10	GND
NA	PA12	—

Allows a single external clock source on the RCLK pin to clock both the SCC receiver and transmitter.

3.6.3 Port B

Port B has 12 pins; however only eight are connected externally.

3.6.3.1 PB7–PB3

Each port B pin may be configured as a general-purpose I/O pin or as a dedicated peripheral interface pin. PB7–PB3 is controlled by the port B control register (PBCNT), the port B data direction register (PBDDR), and the port B data register (PBDAT), and PB7 is configured as an open-drain output ($\overline{\text{WDOG}}$) upon total system reset.

Table 3-3 shows the dedicated function of each pin. The third column shows the input to the peripheral when the pin is used as a general-purpose I/O pin.

Table 3-3. Port B Pin Functions

PBCNT Bit = 1 Pin Function	PBCNT Bit = 0 Pin Function	Input to Interrupt Control and Timers
TIN1	PB3	GND
TIN2	PB5	GND
TOUT2	PB6	—
WDOG	PB7	—

3.6.3.2 PB11–PB8

PB11–PB8 are four general-purpose I/O pins continuously available as general-purpose I/O pins and, therefore, are not referenced in the PBCNT. PB8 operates like PB11–PB9 except that it can also be used as the DRAM refresh controller request pin, as selected in the system control register (SCR).

NOTE

If the PIT is enabled, then the PB8 pin will not generate an interrupt, since the PIT uses the PB8 interrupt in the IPR, IMR, and ISR.

The direction of each pin is determined by the corresponding bit in the PBDDR. The port pin is configured as an input if the corresponding PBDDR bit is cleared; it is configured as an output if the corresponding PBDDR bit is set. PBDDR11–PBDDR8 are cleared on total system reset, configuring all PB11–PB8 pins as general-purpose input pins. When a PB11–PB8 pin is configured as an input, a high-to-low change will cause an interrupt request signal to be sent to the IMP interrupt controller.

3.6.4 Port N

When the LC302 is in 8-bit mode (internal BUSW=0), 8 more general purpose I/O pins are available. The signal direction for each pin is determined by the corresponding control bit in the port N data direction register (PNDDR). The port I/O pin is configured as an input if the corresponding PNDDR bit is cleared; it is configured as an output if the corresponding PNDDR bit is set. The PNDAT register is used to read and write values for the Port N pins.

3.6.5 Port Registers

The I/O port consists of three memory-mapped read-write 16-bit registers for port A and three memory-mapped read-write 16-bit registers for port B. Refer to Figure 3-2. Parallel I/O Port Registers for the I/O port registers. The reserved bits are read as zeros.

Port A Control Register(PACNT)

15	14	13	12	11	10	9	8	7	6	5	4	3	2	1	0
-	-	-	CA	-	CA	CA	CA	CA	CA	CA	CA	CA	CA	CA	CA

0 = I/O 1 = Peripheral

Port A Data Direction Register(PADDR)

15	14	13	12	11	10	9	8	7	6	5	4	3	2	1	0
-	-	-	DA	-	DA	DA	DA	DA	DA	DA	DA	DA	DA	DA	DA

0 = Input 1 = Output

Port A Data Register(PADAT)

15	14	13	12	11	10	9	8	7	6	5	4	3	2	1	0
-	-	-	PA	-	PA	PA	PA	PA	PA	PA	PA	PA	PA	PA	PA

Port B Control Register(PBCNT)

15							8	7	6	5	4	3	2	1	0
RESERVED							CB	CB	CB	-	CB	-	-	-	-

0 = I/O 1 = Peripheral

Port B Data Direction Register(PBDDR)

15	12	11	10	9	8	7	6	5	4	3	2	1	0	
RESERVED				DB	DB	DB	DB	DB	DB	-	DB	-	-	-

0 = Input 1 = Output

Port B Data Register(PBDAT)

15	12	11	10	9	8	7	6	5	4	3	2	1	0	
RESERVED				PB	PB	PB	PB	PB	PB	-	PB	-	-	-

Port N Data Direction Register(PNDDR)

15	14	13	12	11	10	9	8	7	6	5	4	3	2	1	0
DN	DN	DN	DN	DN	DN	DN	DN	RESERVED							

0 = Input 1 = Output

Port N Data Register (PNDAT)

15	14	13	12	11	10	9	8	7	6	5	4	3	2	1	0
PN	PN	PN	PN	PN	PN	PN	PN	RESERVED							

Figure 3-2. Parallel I/O Port Registers

3.7 TIMERS

The IMP includes four timer units: two identical general-purpose timers, a software watchdog timer, and a periodic interrupt timer (PIT).

Each general-purpose timer consists of a timer mode register (TMR), a timer capture register (TCR), a timer counter (TCN), a timer reference register (TRR), and a timer event register (TER). The TMR contains the prescaler value programmed by the user. The software watchdog timer, which has a watchdog reference register (WRR) and a watchdog counter (WCN), uses a fixed prescaler value.

3.7.1 MC68LC302 General Purpose Timer Difference

The only difference between the MC68LC302 and the MC68302 general purpose timers is that Timer 1 output signal is not connected to the externally.

3.7.2 General Purpose Timers Programming Mode

3.7.2.1 Timer Mode Register (TMR1, TMR2)

TMR1 and TMR2 are identical 16-bit registers. TMR1 and TMR2, which are memory-mapped read-write registers to the user, are cleared by reset.

15	8	7	6	5	4	3	2	1	0
PRESCALER VALUE (PS)				CE	OM	ORI	FRR	ICLK	RST

RST—Reset Timer

- 0 = Reset timer (software reset), includes clearing the TMR, TRR, and TCN.
- 1 = Enable timer

ICLK—Input Clock Source for the Timer

- 00 = Stop count
- 01 = Master clock
- 10 = Master clock divided by 16
- 11 = Corresponding TIN pin, TIN1 or TIN2 (falling edge)

FRR—Free Run/Restart

- 0 = Free run—timer count continues to increment after the reference value is reached.
- 1 = Restart—timer count is reset immediately after the reference value is reached.

ORI—Output Reference Interrupt Enable

- 0 = Disable interrupt for reference reached
- 1 = Enable interrupt upon reaching the reference value

OM—Output Mode (**Only available for Timer 1**)

- 0 = Active-low pulse for one CLKO clock cycle (60 ns at 16.67 MHz)
- 1 = Toggle output

CE—Capture Edge and Enable Interrupt

- 00 = Capture function is disabled
- 01 = Capture on rising edge only and enable interrupt on capture event
- 10 = Capture on falling edge only and enable interrupt on capture event
- 11 = Capture on any edge and enable interrupt on capture event

PS—Prescaler Value

The prescaler is programmed to divide the clock input by values from 1 to 256. The value 00000000 divides the clock by 1; the value 11111111 divides the clock by 256.

3.7.2.2 Timer Reference Registers (TRR1, TRR2)

Each TRR is a 16-bit register containing the reference value for the timeout. TRR1 and TRR2 are memory-mapped read-write registers.

3.7.2.3 Timer Capture Registers (TCR1, TCR2)

Each TCR is a 16-bit register used to latch the value of the counter during a capture operation when an edge occurs on the respective TIN1 or TIN2 pin. TCR1 and TCR2 appear as memory-mapped read-only registers to the user.

3.7.2.4 Timer Counter (TCN1, TCN2)

TCN1 and TCN2 are 16-bit up-counters. Each is memory-mapped and can be read and written by the user. A read cycle to TCN1 and TCN2 yields the current value of the timer and does not affect the counting operation.

3.7.2.5 Timer Event Registers (TER1, TER2)

Each TER is an 8-bit register used to report events recognized by any of the timers. On recognition of an event, the timer will set the appropriate bit in the TER, regardless of the corresponding interrupt enable bits (ORI and CE) in the TMR. TER1 and TER2, which appear

to the user as memory-mapped registers, may be read at any time. A bit is cleared by writing a one to that bit (writing a zero does not affect a bit's value).



CAP—Capture Event

The counter value has been latched into the TCR. The CE bits in the TMR are used to enable the interrupt request caused by this event.

REF—Output Reference Event

The counter has reached the TRR value. The ORI bit in the TMR is used to enable the interrupt request caused by this event.

Bits 7–2—Reserved for future use.

3.7.3 Timer 3 - Software Watchdog Timer

A watchdog timer is used to protect against system failures by providing a means to escape from unexpected input conditions, external events, or programming errors. Timer 3 may be used for this purpose. Once started, the watchdog timer must be cleared by software on a regular basis so that it never reaches its timeout value. Upon reaching the timeout value, the assumption may be made that a system failure has occurred, and steps can be taken to recover or reset the system. No changes have been made to the Software Watchdog Timer. Please refer to the *MC68302 Users' Manual* for more information.

3.7.3.1 Software Watchdog Reference Register (WRR)

WRR is a 16-bit register containing the reference value for the timeout. The EN bit of the register enables the timer. WRR appears as a memory-mapped read-write register to the user.



3.7.3.2 Software Watchdog Counter (WCN)

WCN, a 16-bit up-counter, appears as a memory-mapped register and may be read at any time. Clearing EN in WRR causes the counter to be reset and disables the count operation. A read cycle to WCN causes the current value of the timer to be read. A write cycle to WCN causes the counter and prescaler to be reset. A write cycle should be executed on a regular basis so that the watchdog timer is never allowed to reach the reference value during normal program operation.

3.7.4 Periodic Interrupt Timer (PIT)

The MC68LC302 IMP provides a timer to generate periodic interrupts for use with a real-time operating system or the application software. The periodic interrupt time period can vary from 122 μ s to 128 s (assuming a 32.768-kHz crystal is used to generate the general system clock). This function can be disabled.

3.7.4.1 Overview

The periodic interrupt timer consists of an 11-bit modulus counter that is loaded with the value contained in the PITSR. The modulus counter is clocked by the CLKIN signal derived from the IMP EXTAL pin. See Figure 2-2.

The clock source is divided by four before driving the modulus counter (PITCLK). When the modulus counter value reaches zero, an interrupt request signal is generated to the IMP interrupt controller.

The value of bits 11–1 in the PITSR is then loaded again into the modulus counter, and the counting process starts over. A new value can be written to the PITSR only when the PIT is disabled.

The PIT interrupt replaces the IMP PB8 interrupt and is mapped to the PB8 interrupt priority level 4. The PIT Interrupt is maskable by setting bit1 (PB8) in the IMR register.

NOTE

When the PIT is enabled, PB8 can still be used as parallel I/O pin or as DRAM refresh controller request pin, but PB8 will not be capable of generating interrupts.

3.7.4.2 Periodic Timer Period Calculation

The period of the periodic timer can be calculated using the following equation:

$$\text{periodic interrupt timer period} = \frac{\text{PITSR count value}+1}{\frac{((EXTAL)/1 \text{ or } 512)}{(4)}}$$

Solving the equation using a crystal frequency of 32.768 kHz with the prescaler disabled gives:

$$\text{periodic interrupt timer period} = \frac{\text{PITSR count value}+1}{\frac{32768/1}{2^2}}$$

$$\text{periodic interrupt timer period} = \frac{\text{PITSR count value}}{8192}$$

This gives a range from 122 μs, with a PITSR value of \$0, to 250 ms, with a PITSR value of \$7FF (assuming 32.768 khz at the EXTAL pin).

Solving the equation with the prescaler enabled (PTP=1) gives the following values:

$$\text{periodic interrupt timer period} = \frac{\text{PITR count value}}{\frac{32768/512}{2^2}}$$

$$\text{periodic interrupt timer period} = \frac{\text{PITR count value}}{16}$$

This gives a range from 62.5 ms, with a PITR value of \$0 to 128 s, with a PITR value of \$7FF.

For a fast calculation of periodic timer period using a 32.768-kHz crystal, the following equations can be used:

With prescaler disabled:

$$\text{programmable interrupt timer period} = \text{PITR} (122 \mu\text{s})$$

With prescaler enabled:

$$\text{programmable interrupt timer period} = \text{PITR} (62.5 \text{ ms})$$

3.7.4.3 Using the Periodic Timer As a Real-Time Clock

The periodic interrupt timer can be used as a real-time clock interrupt by setting it up to generate an interrupt with a one-second period. When using a 32.768-kHz crystal, the PITR should be loaded with a value of \$0F with the prescaler enabled to generate interrupts at a one-second rate. The interrupt is generated, in this case, at a precise 1 second rate, even if the interrupt is not serviced immediately. A true real time clock is obtained if the current interrupt is serviced completely before the next one occurs.

3.7.4.4 Periodic Interrupt Timer Register (PITR)

The PITR contains control for prescaling the periodic timer as well as the count value for the periodic timer. This register can be read or written only during normal operational mode. Bits 14–13 are not implemented and always return a zero when read. A write does not affect these bits.

PITR								\$0F0
15	14	13	12	11	10	9	8	
PTEN	0	0	PTP	PITR10	PITR9	PITR8	PITR7	
RESET	0	0	0	0	0	0	0	
7	6	5	4	3	2	1	0	
PITR6	PITR5	PITR4	PITR3	PITR2	PITR1	PITR0	RES	
RESET	0	0	0	0	0	0	0	

Read/Write

PTEN—Periodic Timer Enable

This bit contains the enable control for the periodic timer.

- 0 = Periodic timer is disabled
- 1 = Periodic timer is enabled

PTP—Periodic Timer Prescaler Control

This bit contains the prescaler control for the periodic timer.

- 0 = Periodic timer clock is not prescaled
- 1 = Periodic timer clock is prescaled by a value of 512

PITR10–0—Periodic Interrupt Timer Register Bits

These bits of the PITR contain the remaining bits of the PITR count value for the periodic timer. **These bits may be written only when the PIT is disabled (PTEN=0) to modify the PIT count value.**

NOTE

If the PIT is enabled with the PTP bit is set, the first interrupt can be up to 512 clocks early, depending on the prescaler counter value when the PIT is enabled.

3.8 EXTERNAL CHIP-SELECT SIGNALS AND WAIT-STATE LOGIC

The IMP provides a set of four programmable chip-select signals. Each chip-select signal has an identical internal structure. For each memory area, the user may also define an internally generated cycle termination signal (\overline{DTACK}). This feature eliminates board space that would be necessary for cycle termination logic.

The chip-select logic is active for memory cycles generated by internal bus masters (M68000 core, IDMA, SDMA, DRAM refresh) or external bus masters (**A23-A20 are driven to zero internally and FC2-0 are driven to 5**). These signals are driven externally on the falling edge of \overline{AS} and are valid shortly after \overline{AS} goes low.

NOTE

For more information on the operation of the Chip Selects, please refer to Section 3 of the *MC68302 Users' Manual*.

NOTE

Internal Masters (CPU, IDMA and SDMA) drive A23:A20 and FC2-FC0 internally. The CS logic compares the signals to the values programmed in the registers.

In Disable CPU mode or for External Bus Masters, the A23-A20 signals are internally driven to zero, so the user must program

the corresponding bits in the Chip Select registers to zero, or mask off those address bits.

Also FC2-0 are driven to 5, so we suggest that the function code comparison be turned off.

3.8.1 Chip-Select Registers

Each of the four chip-select units has two registers that define its specific operation. These registers are a 16-bit base register (BR) and a 16-bit option register (OR) (e.g., BR0 and OR0). The BR should normally be programmed after the OR since the BR contains the chip-select enable bit.

3.8.1.1 Base Register (BR3–BR0)

These 16-bit registers consist of a base address field, a read-write bit, and a function code field.



FC2–FC0 —Function Code Field

This field is contained in bits 15–13 of each BR. These bits are used to set the address space function code. Because of the priority mechanism and the EN bit, only the $\overline{CS0}$ line is active after a system reset.

Bits 12–2—Base Address

These bits are used to set the starting address of a particular address space.

RW—Read/Write

0 = The chip-select line is asserted for read operations only.

1 = The chip-select line is asserted for write operations only.

EN—Enable

0 = The chip-select line is disabled.

1 = The chip-select line is enabled.

After system reset, only $\overline{CS0}$ is enabled; $\overline{CS3}$ – $\overline{CS1}$ are disabled. In disable CPU mode, $\overline{CS3}$ – $\overline{CS0}$ are disabled at system reset. The chip select does not require disabling before changing its parameters.

3.8.1.2 Option Registers (OR3–OR0)

These four 16-bit registers consist of a base address mask field, a read/write mask bit, a compare function code bit, and a \overline{DTACK} generation field.



Bits 15–12—DTACK Field

These bits are used to determine whether \overline{DTACK} is generated internally with a programmable number of wait states or externally by the peripheral.

Table 3-4. DTACK Field Encoding

Bits			Description
15	14	13	
0	0	0	No Wait State
0	0	1	1 Wait State
0	1	0	2 Wait States
0	1	1	3 Wait States
1	0	0	4 Wait States
1	0	1	5 Wait States
1	1	0	6 Wait States
1	1	1	External DTACK

Bits 12–2—Base Address Mask

These bits are used to set the block size of a particular chip-select line. The address compare logic uses only the address bits that are not masked (i.e., mask bit set to one) to detect an address match.

- 0 = The address bit in the corresponding BR is masked.
- 1 = The address bit in the corresponding BR is not masked.

MRW—Mask Read/Write

- 0 = The RW bit in the BR is masked.
- 1 = The RW bit in the BR is not masked.

NOTE

For correct operation of the CS logic, MRW bit cannot be set in Slave Mode or in systems where an External Master can take ownership of the Bus.

CFC—Compare Function Code

- 0 = The FC bits in the BR are ignored.
- 1 = The FC bits on the BR are compared.

NOTE

Compare Function Code may be useful in systems where only Internal Masters (CPU or DMA) take ownership of the Bus because those masters drive the FC2-0 signals internally. In Slave Mode or in systems where External Masters take ownership of the bus, CFC should be programmed to 0.

3.8.2 Disable CPU Logic (M68000)

The IMP can be configured to operate solely as a peripheral to an external processor. In this mode, the on-chip M68000 CPU should be disabled by strapping DISCPU high during system reset ($\overline{\text{RESET}}$ and $\overline{\text{HALT}}$ asserted simultaneously). The internal accesses to the IMP peripherals and memory may be asynchronous or synchronous. During synchronous reads, one wait state may be used if required (EMWS bit set). The following pins change their functionality in this mode:

1. The $\overline{\text{IPL0}}$ pin becomes $\overline{\text{BR}}$ and is an output from the IDMA and SDMA to the external M68000 bus.
2. The $\overline{\text{IPL2}}$ pin becomes $\overline{\text{BG}}$ and is an input to the IDMA and SDMA from the external M68000 bus. When BG is sampled as low by the IMP, it waits for $\overline{\text{AS}}$, $\overline{\text{HALT}}$, and $\overline{\text{BGACK}}$ to be negated, and then asserts $\overline{\text{BGACK}}$ and performs one or more bus cycles.
3. The $\overline{\text{IPL1}}$ pin becomes $\overline{\text{BGACK}}$ and is an output from the IDMA and SDMA to indicate bus ownership.
4. The $\overline{\text{IPL2-0}}$ lines are no longer encoded interrupt lines. The interrupt controller will output the MC68LC302's interrupt request on $\overline{\text{IOUT2}}$. $\overline{\text{CS0}}$, which is multiplexed with $\overline{\text{IOUT2}}$ is not available in this mode.
5. The $\overline{\text{WEH}}$ and $\overline{\text{WEL}}$ signals become UDS and LDS respectively.
6. The $\overline{\text{OE}}$ becomes $\text{R}/\overline{\text{W}}$.

DISCPU should remain continuously high during disable CPU mode operation. Although the $\overline{\text{CS0}}$ pin is not available as an output from the device in disable CPU mode, it may be enabled to provide $\overline{\text{DTACK}}$ generation. In disable CPU mode, BR0 is initially \$C000.

In disable CPU mode, accesses by an external master to the IMP RAM and registers may be asynchronous or synchronous to the IMP clock. See the SAM and EMWS bits in the SCR for details.

3.8.3 Bus Arbitration Logic

Both internal and external bus arbitration are discussed in the following paragraphs.

3.8.3.1 Internal Bus Arbitration

The IMP bus arbiter supports three bus request sources in the following standard priority:

1. External bus master ($\overline{\text{BR}}$ pin) **(only in Disable CPU mode)**
2. SDMA for the SCCs (six channels)
3. IDMA (one channel)

3.8.3.2 External Bus Arbitration

When the CPU is enabled, an external bus master may gain ownership of the M68000 bus by asserting the $\overline{\text{HALT}}$ signal. This will cause the LC302 bus master (M68000 core, SDMA, or IDMA) to stop at the completion of the current bus cycle. After asserting the $\overline{\text{HALT}}$ signal, the external bus master must wait until $\overline{\text{AS}}$ is negated plus 2 additional system clocks before accessing the bus (to allow the LC302 to threestate all of the bus signals). After gaining own-

ership, the external master can not access the internal IMP registers or RAM. Chip selects and system control functions, such as the hardware watchdog, continue to operate.

When an external master desires to gain ownership, the following bus arbitration protocol should be used:

1. Assert $\overline{\text{HALT}}$.
2. Wait two system clocks.
3. If AS is negated go to step 5.
4. Wait for AS negation. Then wait two additional system clocks.
5. Execute Access (now the bus is guaranteed to be threestated)
6. When done, threestate bus and negate $\overline{\text{HALT}}$.

NOTE

The RMCST bit in the SCR should be zero for this arbitration procedure to work correctly.

Also, the external master cannot access the internal address space of the MC68LC302.

Bus Arbitration is not supported when the MC68LC302 is in one of the low power modes. The chip does not release the address and data lines.

3.9 DYNAMIC RAM REFRESH CONTROLLER

The communications processor (CP) main (RISC) controller may be configured to handle the dynamic RAM (DRAM) refresh task without any intervention from the M68000 core. Use of this feature requires a timer or SCC baud rate generator (either from the IMP or external-ly), the I/O pin PB8, and two transmit buffer descriptors from SCC2 (Tx BD6 and Tx BD7).

No changes have been made to the DRAM controller. For more information, please refer to the *MC68302 Users' Manual*.

SECTION 4

COMMUNICATIONS PROCESSOR (CP)

The CP includes the following modules:

- Main Controller (RISC Processor)
- Four Serial Direct Memory Access (SDMA) Channels
- A Command Set Register
- Serial Channels Physical Interface Including:
 - Motorola Interchip Digital Link (IDL)
 - General Circuit Interface (GCI), Also Known as IOM-2
 - Pulse Code Modulation (PCM) Highway Interface
 - Nonmultiplexed Serial Interface (NMSI) Implementing Standard Modem Signals
- Two Independent Full Duplex Serial Communication Controllers (SCCs) Supporting the Following Protocols:
 - High-Level/Synchronous Data Link Control (HDLC/SDLC)
 - Universal Asynchronous Receiver Transmitter (UART)
 - Autobaud Function to Detect Baud Rate of the Incoming Asynchronous Bit Stream
 - Binary Synchronous Communication (BISYNC)
 - Transparent Modes
- Serial Communication Port (SCP) for Synchronous Communication
- Two Serial Management Controllers (SMCs) to Support the IDL and GCI Management Channels

4.1 MC68LC302 KEY DIFFERENCES FROM THE MC68302

- SCC3 Was Removed.
- The SCP Is Now Multiplexed with the PA8, PA9, and PA10 Pins.
- The DDCMP and V.110 Protocols Were Removed.
- The Autobaud Function Was Added for Detecting the Baud Rate of the Incoming Asynchronous Bit Stream.

This section only presents a description of features and registers that have changed or been added. Features that have not changed such as UART, HDLC, BIYSYNC transparent, the SMCs, and the SCP will not be discussed. For more information on any function not discussed in this section, please refer to the *MC68302 User's Manual*.

This section assumes that the user is familiar with the different protocols. For more information on a specific protocol implementation, please refer to the *MC68302 User's Manual*

4.2 SERIAL CHANNELS PHYSICAL INTERFACE

The serial channels physical interface joins the physical layer serial lines to the two SCCs and the two SMCs. (The separate three-wire SCP interface is described in Serial Communication Port (SCP) on page 25.)

The IMP supports five different external physical interfaces from the SCCs:

1. NMSI—Nonmultiplexed Serial Interface
2. PCM—Pulse Code Modulation Highway
3. IDL—Interchip Digital Link
4. GCI—General Circuit Interface

4.2.1 Serial Interface Registers

There are two serial interface registers: SIMODE and SIMASK. The SIMODE register is a 16-bit register used to define the serial interface operation modes. The SIMASK register is a 16-bit register used to determine which bits are active in the B1 and B2 channels of ISDN.

4.2.1.1 SERIAL INTERFACE MODE REGISTER (SIMODE) . If the IDL or GCI mode is used, this register allows the user to support any or all of the ISDN channels independently. Any extra SCC channel can then be used for other purposes in NMSI mode. The SIMODE register is a memory-mapped read-write register cleared by reset. The changes to this register are marked in **BOLD**.

15	14	13	12	11	10	9	8
SETZ	SYNC/SCIT	SDIAG1	SDIAG0	SDC2	SDC1	B2RB	B2RA

7	6	5	4	3	2	1	0
B1RB	B1RA	DRB	DRA	MSC3	MSC2	MS1	MS0

SETZ—Set L1TXD to Zero (valid only for the GCI interface)

- 0 = Normal operation
- 1 = L1TXD output set to a logic zero (used in GCI activation)

SYNC/SCIT—SYNC Mode/SCIT Select Support (valid only in PCM mode)

- 0 = One pulse wide prior to the 8-bit data
 - 1 = N pulses wide and envelopes the N-bit data
- The SCIT (Special Circuit Interface T) interface mode is valid only in GCI mode.

- 0 = SCIT support disabled
- 1 = SCIT D-channel collision enabled. Bit 4 of channel 2 C/I used by the IMP for receiving indication on the availability of the S interface D channel.

SDIAG1—SDIAG0—Serial Interface Diagnostic Mode (NMSI1 Pins Only)

- 00 = Normal operation
- 01 = Automatic echo
- 10 = Internal loopback
- 11 = Loopback control

SDC2—Serial Data Strobe Control 2

- 0 = SDS2 signal is asserted during the B2 channel
- 1 = SDS1 signal is asserted during the B2 channel

SDC1—Serial Data Strobe Control 1

- 0 = SDS1 signal is asserted during the B1 channel
- 1 = SDS2 signal is asserted during the B1 channel

B2RB, B2RA—B2 Channel Route in IDL/GCI Mode or CH-3 Route in PCM Mode

- 00 = Channel not supported
- 01 = Route channel to SCC1
- 10 = Route channel to SCC2 (if MSC2 is cleared)
- 11 = Route channel to SCC3 (**Not Supported in the MCMC68LC302**)

B1RB, B1RA—B1 Channel Route in IDL/GCI Mode or CH-2 Route in PCM Mode

- 00 = Channel not supported
- 01 = Route channel to SCC1
- 10 = Route channel to SCC2 (if MSC2 is cleared)
- 11 = Route channel to SCC3 (**Not Supported in the MCMC68LC302**)

DRB, DRA—D-Channel Route in IDL/GCI Mode or CH-1 Route in PCM Mode

- 00 = Channel not supported
- 01 = Route channel to SCC1
- 10 = Route channel to SCC2 (if MSC2 is cleared)
- 11 = Route channel to SCC3 (**Not Supported in the MC68LC302**)

MSC3—SCC3 Connection (**Not Supported in the MC68LC302**)

MSC2—SCC2 Connection

- 0 = SCC2 is connected to the multiplexed serial interface (PCM, IDL, or GCI) chosen in MS1—MS0. NMSI2 pins are all available for other purposes.
- 1 = SCC2 is not connected to a multiplexed serial interface but is either connected directly to the NMSI2 pins or not used. The choice of general-purpose I/O port pins versus SCC2 functions is made in the port A control register.

MS1—MS0—Mode Supported

- 00 = NMSI Mode
- 01 = PCM Mode
- 10 = IDL Mode
- 11 = GCI Interface

4.2.1.2 SERIAL INTERFACE MASK REGISTER (SIMASK) .The SIMASK register, a memory-mapped read-write register, is set to all ones by reset. SIMASK is used in IDL and GCI to determine which bits are active in the B1 and B2 channels. Any combination of bits may be chosen. A bit set to zero is not used by the IMP. A bit set to one signifies that the corresponding B channel bit is used for transmission and reception on the B channel. Note that the serial data strobes, SD1 and SD2, are asserted for the entire 8-bit time slot independent of the setting of the bits in the SIMASK register.

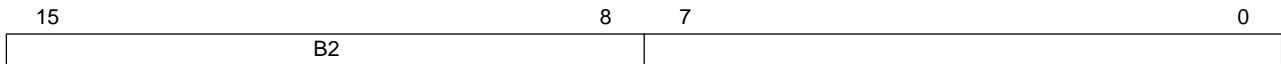

NOTE

Bit 0 of this register is the first bit transmitted or received on the IDL/GCI B1 channel.

4.3 SERIAL COMMUNICATION CONTROLLERS (SCCS)

The IMP contains two independent SCCs, each of which can implement different protocols. This configuration provides the user with options for controlling up to two independent full-duplex lines implementing bridges or gateway functions or multiplexing both SCCs onto the same physical layer interface to implement a two channels on a time-division multiplexed (TDM) bus. Each protocol-type implementation uses identical buffer structures to simplify programming.

4.3.1 SCC Configuration Register (SCON)

Each SCC controller has a configuration register that controls its operation and selects its clock source and baud rate. This register has not been changed from the MC68302.

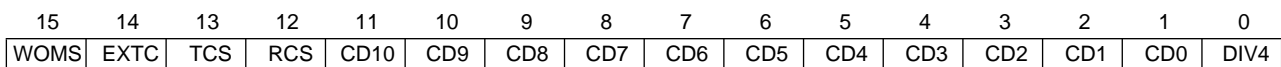

4.3.1.1 DIVIDE BY 2 INPUT BLOCKS (NEW FEATURE). The SCC Baud Rate Generators have 2 divide by 2 blocks added to them. With the divide by 2 blocks enabled, the VCO Output from the PLL and the TIN1 input clock can be divided by 2 before they are used by the BRG to generate the serial clocks. The divide by two blocks can be enabled by setting the BCD bit in the IOMCR register if the BRG clock source is derived from the IMP system clock, or by setting the BRGDIV bit in the DISC register if the BRG clock source is derived from the TIN pin.

4.3.2 Disable SCC1 Serial Clocks Out (DISC)

The Disable SCC1 Serial Clocks Out (DISC) is an 16-bit read/write register. The upper 8 bits control: (1) enabling the divide by 2 prescaler for the baud rate generator from the TIN1 pin, and (2) options for three stating theTCLK1, and RCLK1 pins.

DISC								Base+\$8EE
15	14	13	12	11	10	9	8	
TSTCLK1	TSRCLK1		BRGDIV					
RESET:	0	0	0	0	0	0	0	
0								
7	6	5	4	3	2	1	0	
RESET:	0	0	0	0	0	0	0	
0								

4.3.2.1 RCLK1 AND TCLK1 PIN OPTIONS.

TSRCLK1

- 0 = RCLK1 is driven on its pin when SCC1 RCLK is the baud rate generator output.
- 1 = RCLK1 is three-state.

TSTCLK1

- 0 = TCLK1 is driven on its pin when SCC1 RCLK is the baud rate generator output.
- 1 = TCLK1 is three-state.

BRGDIV

Enables and disables the divide by two block between the TIN1 pin and the BRG1 prescaler input.

- 0 = The divide by two block is disabled.
- 1 = The divide by two block is enabled.

4.3.3 SCC Mode Register (SCM)

Each SCC has a mode register. The functions of bits 5–0 are common to each protocol. The function of the specific mode bits varies according to the protocol selected by the MODE1–MODE0 bits. They are described in the relevant sections for each protocol type. Each SCM is a 16-bit, memory-mapped, read-write register. The SCMs are cleared by reset.

Only the Mode bits have changed functionality. For more information on the other bits, please refer to the *MC68302 Users' Manual*.

15	6	5	4	3	2	1	0				
SPECIFIC MODE BITS						DIAG1	DIAG0	ENR	ENT	MODE1	MODE0

DIAG1–DIAG0—Diagnostic Mode

- 00 = Normal operation (\overline{CTS} , \overline{CD} lines under automatic control)
- 01 = Loopback mode
- 10 = Automatic echo
- 11 = Software operation

ENR— Enable Receiver

When ENR is set, the receiver is enabled. When it is cleared, the receiver is disabled, and any data in the receive FIFO is lost. If ENR is cleared during data reception, the receiver aborts the current character. ENR may be set or cleared regardless of whether serial

clocks are present. To restart reception, the ENTER HUNT MODE command should be issued before ENR is set again.

ENT—Enable Transmitter

When ENT is set, the transmitter is enabled; when ENT is cleared, the transmitter is disabled. If ENT is cleared, the transmitter will abort any data transmission, clear the transmit data FIFO and shift register, and force the TXD line high (idle). Data already in the transmit shift register will not be transmitted. ENT may be set or cleared regardless of whether serial clocks are present.

MODE1—MODE0—Channel Mode

- 00 = HDLC
- 01 = Asynchronous (UART)
- 10 = **Reserved**
- 11 = BISYNC, Promiscuous Transparent, and **Autobaud**

4.3.4 SCC Data Synchronization Register (DSR)

Each DSR is a 16-bit, memory-mapped, read-write register. DSR specifies the pattern used in the frame synchronization procedure of the SCC in the synchronous protocols. In the UART protocol it is used to configure fractional stop bit transmission. After reset, the DSR defaults to \$7E7E (two FLAGS); thus, no additional programming is necessary for the HDLC protocol. For BISYNC the contents of the DSR should be written before the channel is enabled.

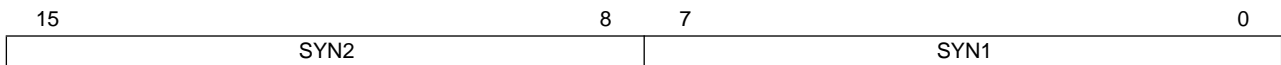

4.3.5 Buffer Descriptors Table

Data associated with each SCC channel is stored in buffers. Each buffer is referenced by a buffer descriptor (BD). BDs are located in each channel's BD table (located in dual-port RAM). There are two such tables for each SCC channel: one is used for data received from the serial line; the other is used to transmit data. The format of the BDs is the same for each SCC mode of operation (HDLC, UART, BISYNC, and transparent) and for both transmit or receive. Only the first field (containing status and control bits) differs for each protocol. The BD format is shown in Figure 4-1.

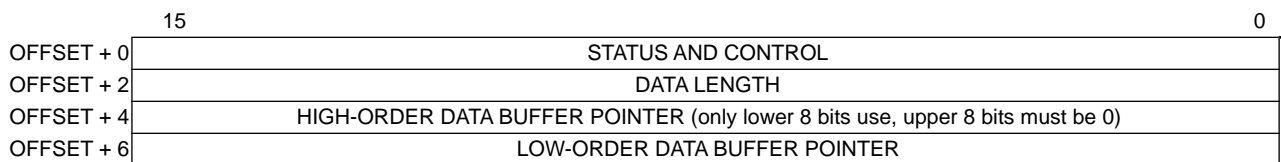

Figure 4-1. SCC Buffer Descriptor Format

NOTE

Even though the address bus is only 20 bits, the full 32-bit pointer must be Bits 24-32 must be zero, and bits 20-23 are used in

the Chip Select address comparison, so they should be programmed to a value which will assert the desired chip select.

4.3.6 SCC Parameter RAM Memory Map

Each SCC maintains a section in the dual-port RAM called the parameter RAM. Each SCC parameter RAM area begins at an offset \$80 from each SCC base area (\$400 or \$500) and continues through offset \$BF. Part of each SCC parameter RAM (offset \$80–\$9A), which is identical for each protocol chosen, is shown in Table 4-1. Offsets \$9C–\$BF comprise the protocol-specific portion of the SCC parameter RAM. The SCC parameters have not changed functionality from the MC68302.

Table 4-1. SCC Parameter RAM Memory Map

Address	Name	Width	Description
SCC Base + 80 #	RFCR	Byte	Rx Function Code
SCC Base + 81 #	TFCR	Byte	Tx Function Code
SCC Base + 82 #	MRBLR	Word	Maximum Rx Buffer Length
SCC Base + 84 ##		Word	Rx Internal State
SCC Base + 86 ##		Byte	Reserved
SCC Base + 87 ##	RBD#	Byte	Rx Internal Buffer Number
SCC Base + 88		2 Words	Rx Internal Data Pointer
SCC Base + 8C		Word	Rx Internal Byte Count
SCC Base + 8E		Word	Rx Temp
SCC Base + 90 ##		Word	Tx Internal State
SCC Base + 92 ##		Byte	Reserved
SCC Base + 93 ##	TBD#	Byte	Tx Internal Buffer Number
SCC Base + 94		2 Words	Tx Internal Data Pointer
SCC Base + 98		Word	Tx Internal Byte Count
SCC Base + 9A		Word	Tx Temp
SCC Base + 9C			First Word of Protocol-Specific Area
SCC Base + BF			Last Word of Protocol-Specific Area

Should be initialized by the user (M68000 core).

Modified by the CP following a CP or system reset.

4.3.7 Interrupt Mechanism

The interrupt mechanism for each SCC is the same as the MC68302.

4.3.8 UART Controller

The functionality of the UART controller has not changed. The new Autobaud feature is discussed in 4.3.9 Autobaud Controller (New). For any additional information on parameters, registers, and functionality, please refer to the *MC68302 Users' Manual*.

4.3.8.1 UART MEMORY MAP. When configured to operate in UART mode, the IMP overlays the structure (see Table 4-2) onto the protocol-specific area of that SCC's parameter RAM. Refer to System Configuration Registers on page 5 for the placement of the three SCC parameter RAM areas and to Table 4-1 for the other parameter RAM values

Table 4-2. UART Specific Parameter RAM

Address	Name	Width	Description
SCC Base + 9C # SCC Base + 9E SCC Base + A0 #	MAX_IDL IDLC BRKCR	Word Word Word	Maximum IDLE Characters (Receive) Temporary Receive IDLE Counter Break Count Register (Transmit)
SCC Base + A2 # SCC Base + A4 # SCC Base + A6 # SCC Base + A8 #	PAREC FRMEC NOSEC BRKEC	Word Word Word Word	Receive Parity Error Counter Receive Framing Error Counter Receive Noise Counter Receive Break Condition Counter
SCC Base + AA # SCC Base + AC #	UADDR1 UADDR2	Word Word	UART ADDRESS Character 1 UART ADDRESS Character 2
SCC Base + AE SCC Base + B0 # SCC Base + B2 # SCC Base + B4 # SCC Base + B6 # SCC Base + B8 # SCC Base + BA # SCC Base + BC # SCC Base + BE #	RCCR CHARACTER1 CHARACTER2 CHARACTER3 CHARACTER4 CHARACTER5 CHARACTER6 CHARACTER7 CHARACTER8	Word Word Word Word Word Word Word Word Word	Receive Control Character Register CONTROL Character 1 CONTROL Character 2 CONTROL Character 3 CONTROL Character 4 CONTROL Character 5 CONTROL Character 6 CONTROL Character 7 CONTROL Character 8

Initialized by the user (M68000 core).

4.3.8.2 UART MODE REGISTER. Each SCC mode register is a 16-bit, memory- mapped, read-write register that controls the SCC operation. The read-write UART mode register is cleared by reset.

15	14	13	12	11	10	9	8	7	6	5	COMMON SCC MODE BITS				0
TPM1	TPM0	RPM	PEN	UM1	UM0	FRZ	CL	RTSM	SL						

4.3.8.3 UART RECEIVE BUFFER DESCRIPTOR (RX BD). The CP reports information about each buffer of received data by its BDs. The Rx BD is shown in Figure 4-2.

	15	14	13	12	11	10	9	8	7	6	5	4	3	2	1	0
OFFSET + 0	E	X	W	I	C	A	M	ID	—	—	BR	FR	PR	—	OV	CD
OFFSET + 2	DATA LENGTH															
OFFSET + 4	RX BUFFER POINTER (24-bits used, upper 8 bits must be 0)															
OFFSET + 6																

Figure 4-2. UART Receive Buffer Descriptor

4.3.8.4 UART TRANSMIT BUFFER DESCRIPTOR (TX BD). Data is presented to the CP for transmission on an SCC channel by arranging it in buffers referenced by the channel's Tx BD table. The Tx BD shown in Figure 4-3.

	15	14	13	12	11	10	9	8	7	6	5	4	3	2	1	0
OFFSET + 0	R	X	W	I	CR	A	P	—	—	—	—	—	—	—	—	CT
OFFSET + 2	DATA LENGTH															
OFFSET + 4	TX BUFFER POINTER (24-bits used, upper 8 bits must be 0)															
OFFSET + 6																

Figure 4-3. UART Transmit Buffer Descriptor

4.3.8.5 UART EVENT REGISTER. The SCC event register (SCCE) is called the UART event register when the SCC is operating as a UART.

7	6	5	4	3	2	1	0
CTS	CD	IDL	BRK	CCR	BSY	TX	RX

4.3.8.6 UART MASK REGISTER. The SCC mask register (SCCM) is referred to as the UART mask register when the SCC is operating as a UART. If a bit in the UART mask register is a one, the corresponding interrupt in the event register will be enabled. If the bit is zero, the corresponding interrupt in the event register will be masked. This register is cleared upon reset.

4.3.9 Autobaud Controller (New)

The autobaud function determines the baud rate and format of an asynchronous data stream starting with a known character. This controller may be used to implement the standard AT command set or other characters.

In order to use the autobaud mode, the serial communication controller (SCC) is initially programmed to BISYNC mode. The SCC receiver then synchronizes on the falling edge of the START bit. Once a START bit is detected, each bit received is processed by the autobaud controller. The autobaud controller measures the length of the START bit to determine the receive baud rate and compares the length to values in a user supplied lookup table. After the baud rate is determined, the autobaud controller assembles the character and compares it against two user-defined characters. If a match is detected, the autobaud controller interrupts the host and returns the determined nominal start value from the lookup table. The autobaud controller continues to assemble the characters and interrupt the host until the host stops the reception process. The incoming message should contain a mixture of even and odd characters so that the user has enough information to decide on the proper character format (length and parity). The host then uses the returned nominal start value from the lookup table, modifies the SCC configuration register (SCON) to generate the correct baud rate, and reprograms the SCC to UART mode.

Many rates are supported including: 150, 300, 600, 1200, 2400, 4800, 9600, 14.4K, 19.2K, 38.4K, 57.6K, 64K, 96K, 115.2K and 230K. To estimate the performance of the autobaud mode, the performance table in Appendix A can be used. The maximum full-duplex rate for a BISYNC channel is one-tenth of the system clock rate. So a 25 MHz IMP can support 230K autobaud rate with another low-speed channel (<50 kbps) and a 20 MHz IMP can support 115.2K autobaud rate with 2 low-speed channels. The performance can vary depending on system loading, configuration, and echoing mode.

It is important that the highest priority SCC be used for the autobaud function, since it is running at a very high rate. Any SCC that is guaranteed to be idle during the search operation of the autobaud process will not impact the performance of autobaud in an application. Idle is defined as not having any transmit or receive requests to/from the SCC FIFOs.

4.3.9.1 AUTOBAUD CHANNEL RECEPTION PROCESS. The interface between the autobaud controller and the host processor is implemented with shared data structures in the

SCC parameter RAM and in external memory and through the use of a special command to the SCC.

The autobaud controller uses receive buffer descriptor number 7 (Rx BD7) for the autobaud command descriptor. This Rx BD is initialized by the host to contain a pointer to a lookup table residing in the external RAM (contains the maximum and nominal START bit length for each baud rate). The host also prepares two characters against which the autobaud controller will compare the received character (usually these characters are 'a' and 'A') and the host initializes a pointer to a buffer in external memory where the assembled characters will be stored until the host stops the autobaud process. Finally, the host initializes the SCC data synchronization register (DSR) to \$7FFF in order to synchronize on the falling edge of the START bit.

Once the data structures are initialized, the host programs the SCON register to provide a sampling clock that is 16X the maximum supported baud rate. The host then issues the Enter_Baud_Hunt command and enables the SCC in the BISYNC mode.

The autobaud controller reception process begins when the START bit arrives. The autobaud controller then begins to measure the START bit length. With each byte received from the SCC that "belongs" to the START bit, the autobaud controller increments the start length counter and compares it to the current lookup table entry. If the start length counter passed the maximum bit length defined by the current table entry, the autobaud controller switches to the next lookup table entry (the next slower baud rate). This process goes on until the autobaud controller recognizes the end of the START bit. Then, the autobaud controller starts the character assembly process.

The character assembly process uses the nominal bit length, taken from the current lookup table entry, to sample each incoming bit in its center. Each bit received is stored to form an 8-bit character. When the assembly process is completed (a STOP bit is received), the character is compared against two user-defined characters.

If the received character does not match any of the two user defined characters, the autobaud controller re-enters the Enter_Baud_Hunt process. The host is not notified until a match is encountered.

If a match is found, the character is written to the received control character register (RCCR) with the corresponding status bit set in Rx BD7. The channel will generate the control character received (CCR) interrupt (bit 3 in the SCCE), if enabled. If the character matched, but a framing error was detected on the STOP bit, the autobaud controller will also set the framing error status bit in Rx BD7.

The autobaud controller then continues to assemble the incoming characters and to store them in the external data buffer. The host receives a CCR interrupt after each character is received. The host is responsible for determining the end of the incoming message (for example, a carriage return), stopping the autobaud process, and reprogramming the SCC to UART mode. The autobaud controller returns the nominal START bit length value for the detected baud rate from the lookup table and a pointer to the last character received that was written to the external data buffer. The host must be able to handle each character inter-

rupt in order to determine parity and character length (this information may be overwritten when the next character interrupt is presented to the host). The host uses the two received characters to determine 1) whether a properly formed “at” or “AT” was received, and 2) the proper character format (character length, parity).

Once this is decided, three possible actions can result. First, the host may decide that the data received was not a proper “at” or “AT”, and issue the Enter_Baud_Hunt command to cause the autobaud controller to resume the search process. Second, the host may decide the “at” or “AT” is proper and simply continue to receive characters in BISO mode. Third, the M68000 core may decide that the “at” or “AT” is proper, but a change in character length or parity is required.

4.3.9.2 AUTOBAUD CHANNEL TRANSMIT PROCESS. The autobaud microcode package supports two methods for transmission. The first method is automatic echo which is supported directly in the SCC hardware, and the second method is a smart echo or software transmit which is supported with an additional clock and software.

Automatic echo is enabled by setting the DIAG bits in the SCC mode register (SCM) to ‘10’ and asserting the \overline{CD} pin (externally on SCC1 and on SCC2 and SCC3, either externally or by leaving the pin as a general purpose input). The ENT bit of the SCC should remain cleared. The transmitter is not used, so this echoing method does not impact performance.

The smart echo or software transmit requires use of an additional clock and the transmitter, so the overall performance could be affected if other SCCs are running. This method requires an additional clock for sampling the incoming bit stream since the baud rate generator (BRG) must be used to provide the correct frequency for transmission. The user needs to provide the sampling clock that will be used for the autobaud function on the RCLK pin (for example, a 1.8432 MHz clock for 115.2K). The clock that will be used for the SCC transmission can be provided to the BRG from the system clock or on TIN1. The TIN1 and RCLK1 pins can be tied together externally. After the first two characters have been received and character length and parity determined, the host programs the DSR to \$FFFF, enables the transmitter (by setting ENT), and programs the transmit character descriptor (overlays CONTROL Character 8). The host is interrupted after each character is transmitted.

For modem applications with the MC68LC302, SCC2 will be used as the DTE interface and autobauding to the DTE baud rate will often be required. If use of the smart echo feature is desired, the receive clock can be provided by the baud rate generator 2 (BRG2) internally by resetting the RCS bit in the SCON2 register to zero. The separate transmit clock can be provided externally to the TCLK2 pin through a hardware connection. The TCS bit in the SCON2 register should be set to one to enable the external clock source. After autobauding is complete, both the transmit and receive clock sources can be derived internally from BRG2 and the external pin connected to TCLK2 should be three stated to assure that it does not contend with the TCLK2 pin.

4.3.9.3 AUTOBAUD PARAMETER RAM. When configured to operate in the autobaud mode, the IMP overlays some entries of the UART-specific parameter RAM as illustrated in Table 4-3.

Table 4-3. Autobaud Specific Parameter

Address	Name	Width	Description
SCC Base + 9C *	MAX_IDL	Word	Maximum IDLE Characters
SCC Base + 9E	MAX_BIT	Word	Current Maximum START Bit Length
SCC Base + A0	NOM_START	Word	Current Nom. START Bit (used to determine baud rate)
SCC Base + A2 *	PAREC	Word	Receive Parity Error Counter
SCC Base + A4 *	FRMEC	Word	Receive Framing Error Counter
SCC Base + A6 *	NOSEC	Word	Receive Noise Counter
SCC Base + A8 *	BRKEC	Word	Receive Break Error Counter
SCC Base + AA *	ABCHR1	Word	User Defined Character1
SCC Base + AC *	ABCHR2	Word	User Defined Character2
SCC Base + AE	RCCR	Word	Receive Control Character Register
SCC Base + B0 *	CHARACTER1	Word	CONTROL Character1
SCC Base + B2 *	CHARACTER2	Word	CONTROL Character2
SCC Base + B4 *	CHARACTER3	Word	CONTROL Character3
SCC Base + B6 *	CHARACTER4	Word	CONTROL Character4
SCC Base + B8 *	CHARACTER5	Word	CONTROL Character5
SCC Base + BA *	CHR6/RxPTR	Word	CONTRChar6/MSW of pointer to external Rx Buffer
SCC Base + BC *	CHR7RxPTR	Word	CONTRChar7/LSW of pointer to external Rx Buffer
SCC Base + BE *	CHR8/TxBD	Word	CONTROL Character8/Transmit BD

* These values should be initialized by the user (M68000 core).

Note the new parameters that have been added to the table. They are MAX_BIT, NOM_START, ABCHR1, ABCHR2, RxPTR (2 words), and TxBD. These parameters are of special importance to the autobaud controller. They must be written prior to issuing the Enter_Baud_Hunt command.

When the channel is operating in the autobaud hunt mode, the MAX_BIT parameter is used to hold the current maximum START bit length. The NOM_START location contains the current nominal start from the lookup table. After the autobaud is successful and the first character is matched, the user should use the NOM_START value from the autobaud specific parameter RAM to determine which baud rate from the lookup table was detected. Also the Tx internal data pointer (at offset SCC Base + 94) will point to the last character received into external data buffer.

NOTE

When the channel is operating in the UART mode, the NOM_START_/BRKCR is used as the break count register and must be initialized before a STOP_TRANSMIT command is issued.

The characters ABCHR1 and ABCHR2 are the autobaud characters that should be searched for by the autobaud controller. Typically these are 'a' and 'A' (i.e. \$0061 and \$0041) if using the Hayes command set. These characters must be odd in order for the autobaud controller to correctly determine the length of the START bit. Characters are transmitted and received least significant bit first, so the autobaud controller detects the end of the START bit by the least significant bit of the character being a '1'.

The RxPTR is a 2 word location that contains a 32-bit pointer to a buffer in external memory used for assembling the received characters and must be initialized before the Enter_Baud_Hunt command is issued.

NOTE

Since a length for this external buffer is not given, the user must provide enough space in memory for characters to be assembled and written until the autobaud process is to avoid overwriting other data in memory. This location is not used as the CHARACTER7 value in the control character table until the channel operates in normal UART mode. After reception begins in normal UART mode (i.e. the “a” or “A” is found), this entry is available again as a control character table entry.

The TxBD entry is used as the transmit character descriptor for smart echo or software transmit. This location is not used as the CHARACTER8 value in the control character table until the channel operates in normal UART mode. After reception begins in normal UART mode (i.e. the “a” or “A” is found), this entry is available again as a control character table entry.

4.3.9.4 AUTOBAUD PROGRAMMING MODEL. The following sections describe the details of initializing the autobaud microcode, preparing for the autobaud process, and the memory structures used.

4.3.9.4.1 Preparing for the Autobaud Process. The host begins preparation for the autobaud process with the following steps. Steps 1 and 2 are required if the SCC has been used after reset or after UART mode in order to re-enable the process.

1. Disable the SCC by clearing the ENR and ENT bits. (The host may wish to precede this action with the STOP_TRANSMIT commands to abort transmission in an orderly way).
2. Issue the ENTER_HUNT_MODE command to the SCC (This ensures that an open buffer descriptor is closed).
3. Set up all the autobaud parameters in the autobaud specific parameter RAM shown in Table 4-3, the autobaud command descriptor shown in Table 4-4, and the lookup table shown in Table 4-4. Of these three areas, the autobaud controller only modifies the autobaud specific parameter RAM and the first word of the autobaud command descriptor during its operation.
4. Write the SCON to configure the SCC to use the baud rate generator clock of 16x the maximum supported baud rate. A typical value is \$4000 assuming a 1.8432 MHz clock rate on TIN1 and a maximum baud rate of 115.2K, but this can change depending on the maximum baud rate and the EXTAL frequency.
5. Write the DSR of the SCC with the value \$7FFF in order to detect the START bit.
6. The host initiates the autobaud search process by issuing the Enter_Baud_Hunt command
7. Write the SCM of the SCC with \$1133 to configure it for BISYNC mode, with the REVD

and RBCS bits set, software operation mode, and the transmitter disabled. After a few characters have been received, the transmitter can be enabled, and the software echo function may be performed after issuing the RESTART TRANSMIT command.

In general, the autobaud controller uses the same data structure as that of the UART controller. The first character (if matched) is stored in the receiver control character register and the external data buffer, and the status of that character is reported in the autobaud command descriptor. After the first character, each incoming character is then stored in the buffer pointed to by RxPTR, and the status is updated in the autobaud command autobaud descriptor. The Tx internal data pointer (at offset SCC Base + 94) is updated to point to the last character stored in the external data buffer.

4.3.9.4.2 Enter_Baud_Hunt Command. This command instructs the autobaud controller to begin searching for the baud rate of a user predefined character. Prior to issuing the command the M68000 prepares the autobaud command descriptor to contain the lookup table size and pointer.

The Enter_Baud_Hunt uses the GCI command with opcode = 10, and the channel number set for the corresponding SCC. For example, with SCC1, the value written to the command register would be \$61.

4.3.9.4.3 Autobaud Command Descriptor. The autobaud controller uses the receive buffer descriptor number 7 (Rx BD7) as an autobaud command descriptor. The autobaud command descriptor is used by the M68000 core to transfer command parameters to the autobaud controller, and by the autobaud controller to report information concerning the received character.

The structure of the autobaud command descriptor for the autobaud process is shown in Table 4-4. The first word of the descriptor or the status word is updated after every character is received.

Table 4-4. Autobaud Command Descriptor

Offset	15	14	13	12	11	10	9	8	7	6	5	4	3	2	1	0	
0							FE	M2	M1					EOT		OV	CD
2	Lookup Table Size																
4	Function Code																
8	Lookup Table Pointer																

FE – Framing Error (Bit 10)

If this bit is set, a character with a framing error was received. A framing error is detected by the autobaud controller when no STOP bit is detected in the received data. FE will be set for a 9-bit character (8 bits + parity) if the parity bit is '0'.

NOTE

The user must clear this bit when it is set.

M2 – Match Character2 (Bit 9)

When this bit is set, the character received matched the User Defined Character 2. The received character is written into the receive control character register (RCCR).

M1 – Match Character1 (Bit 8)

When this bit is set, the character received matched the User Defined Character 1. The received character is written into the receive control character register (RCCR).

EOT – End Of Table (bit 3)

When this bit is set, the autobaud controller measured start length exceeded the maximum start length of the last entry in the lookup table (lowest baud rate).

NOTE

The user must clear this bit when it is set.

OV – Overrun (bit 1)

If this bit is set, a receiver overrun occurred during autobaud reception.

NOTE

The user must clear this bit when it is set.

CD – Carrier Detect Lost (bit 0)

If this bit is set, the carrier detect signal was negated during autobaud reception.

NOTE

The user must clear this bit when it is set.

Lookup Table Size - Lookup table size is the number of baud rate entries in the external lookup table.

Lookup Table Pointer - The lookup table pointer is the address in the external RAM where the lookup table begins.

NOTE

The lookup table cannot cross a 64k memory block boundary.

4.3.9.4.4 Autobaud Lookup Table. The autobaud controller uses an external lookup table to determine the baud rate while in the process of receiving a character. The lookup table contains two entries for each supported baud rate. The first entry is the maximum start length for the particular baud rate, and the second entry is the nominal length for a 1/2 START bit.

To determine the two values for each table entry, first calculate the autobaud sampling rate (EQ 2). To do this EQ 1 must be used until EQ 2 is satisfied. The sampling rate is the lowest speed baud rate that can be generated by the SCC baud rate generator that is over a threshold defined in EQ 2.

$$\text{BRG Clk Rate} = \text{System Clock or TIN1} / ((\text{Clock Divider bits in SCON}) + 1) \quad (\text{EQ 1})$$

assuming that the DIV bit in SCON is set to 0, (otherwise an additional “divide-by-4” must be included).

$$\text{Sampling Rate} = \text{BRG Clk Rate, where BRG Clk rate} \geq (\text{Max Desired UART Baud Rate}) \times 16 \quad (\text{EQ 2})$$

For instance, if a 115.2K baud rate is desired, with a 16.67 MHz system clock, the minimum sampling rate possible is 1.843 MHz = 115.2K x 16. This exact frequency can be input to RCLK1 or TIN1 as the sample clock. If the system clock is to be used, a 16.67 MHz system clock cannot produce an exact baud rate clock of 1.843 MHz. The lowest one that can be used is Baud Rate = 16.67 MHz / (7+1) = 2.083 MHz. Thus, 2.083 MHz is the sampling rate, and the SCON should be set to \$000E to produce this.

Once the sampling rate is known, the other two equations follow easily. The maximum START bit length is calculated by the following equation:

$$\text{Maximum start length} = (\text{Sampling Rate/Recognized baud rate}) \times 1.05 \quad (\text{EQ 3})$$

Thus, for the first entry in the table, the maximum start length is 1.8432 Mhz/115200 x 1.05 = 17 for an external sample clock. The value 1.05 is a suggested margin that allows characters 5% larger than the nominal character rate to be accepted. In effect, the margin determines the “split point” between what is considered to be a 56.7K character rate and what is a 38.4K character rate. The margin should not normally be less than 1.03 due to clocking differences between UARTs.

The nominal START bit length is calculated by:

$$\text{Nominal start length} = (\text{Sampling Rate/Recognized baud rate}) / 2 \quad (\text{EQ 4})$$

For the 115.2K example in the first table entry, this would be 1.8432 MHz/115.2K/2 = 8.

The structure of the lookup table is shown in Table 4-5. The table starts with the maximum UART baud rate supported and ends with the minimum UART baud rate supported.

Table 4-5. Autobaud Lookup Table Format

OFFSET from Lookup Table Pointer	Description
0	Maximum Start Length
2	Nominal Start Length
4	Maximum Start Length
6	Nominal Start Length
•	Maximum Start Length
•	Nominal Start Length
(Lookup Table Size - 1) * 4	Maximum Start Length
[(Lookup Table Size - 1) * 4] + 2	Nominal Start Length

NOTE

If less margin is used in the calculation of the maximum start length above, it is possible to distinguish between close UART rates such as 64K and 57.6K. However variations in RS232 drivers of up to 4%, plus nominal clocking rate variations of 3%, plus

the fact that the sampling rate may not perfectly divide into the desired UART rate, can make this distinction difficult to achieve in some scenarios.

4.3.9.5 LOOKUP TABLE EXAMPLE.

Table 4-6 is an example autobaud lookup table. The maximum start and nominal start values are derived assuming a 1.8432 MHz sampling clock on TIN1 or RCLK and a shift factor of 5%.

Table 4-6. Lookup Table Example

Desired Baud Rate	Maximum Start	Nominal Start
115200	17	8
57600	34	16
38400	50	24
28800	67	32
19200	101	48
14400	134	64
12000	161	77
9600	202	96
7200	269	128
4800	403	192
2400	806	384
1200	1613	768
600	3226	1536
300	6451	3072
110	17594	8378

4.3.9.6 DETERMINING CHARACTER LENGTH AND PARITY. Table 4-7 shows the different possible character lengths and parity that will be discussed. The following paragraphs will discuss for each case how to determine the parity.

Table 4-7. Character Lengths and Parity Cases

Case #	Character Length	Parity	Notes
1	7-bit	No parity, 1 STOP bit	Not Supported
2	7-bit	Even parity Odd parity Parity=1 Parity=0	Parity is indicated by the most significant bit of the byte
3	8-bit	No parity	Same as 7-bit, parity=0
4	8-bit	Even parity Odd parity Parity=0	Parity is indicated by which characters generate a FE interrupt
5	8-bit	Parity=1	Not Supported

- Case 1– This case cannot be supported because the autobaud can not separate the first character from the second character.

- Case 2— As each character is assembled, it is stored into a complete byte. Assuming that the characters are ASCII characters with 7-bit codes, the 8th bit of the byte will contain the parity bit. If the parity is either even or odd, then after receiving an odd character and an even character, the 8th bit should be different for the odd and even characters. The parity can be determined by the setting of the parity bit for one of the two characters. If the 8th bit is always a 1, this is the same as a 7-bit character, no parity and at least 2 STOP bits or a 7-bit character with force 1 parity. If the 8th bit is always a zero, then either the character is a 7-bit character with force 0 parity, or the character is a 8-bit character with no parity.
- Case 3— This case is the same as 7-bit character with force 0 parity. The 8th bit of the byte will always be zero.
- Case 4— This case assumes a 8-bit character with the 8th bit of the character equal to a 0 (ASCII character codes define the 8th bit as zero). If the parity is either even or odd, then after receiving an odd and an even character, a framing error (FE) interrupt should have been generated for one of them (the interrupt is generated when the parity bit is zero). The user can determine the parity by which character generated a FE interrupt (if the odd character did, then the parity is odd). If a framing error occurs on every character, then the character is 8-bits with force 0 parity. If no framing error occurs, than this is the same as Case 5.
- Case 5— This case is not supported, because it can not be differentiated from 7-bit force 0 parity and 8-bit no parity. If the 9th bit is a 1, then it will be interpreted as a STOP bit.

4.3.9.7 AUTOBAUD RECEPTION ERROR HANDLING PROCEDURE. The autobaud controller reports reception error conditions using the autobaud command descriptor. Three types of errors are supported:

- Carrier Detect Lost during reception

When this error occurs and the channel is not programmed to control this line with software, the channel terminates reception, sets the carrier detect lost (CD) bit in the command descriptor, and generates the CCR interrupt, if enabled. CCR is bit 3 of the SCCE register.

- Overrun Error

When this error occurs, the channel terminates reception, sets the overrun (OV) bit in the command descriptor, and generates the CCR interrupt, if enabled.

- End Of Table Error

When this error occurs, the channel terminates reception, sets the end of table (EOT) bit in the command descriptor, and generates the CCR interrupt, if enabled.

Any of these errors will cause the channel to abort reception. In order to resume autobaud operation after an error condition, the M68000 should clear the status bits and issue the Enter_Baud_Hunt command again.

4.3.9.8 AUTOBAUD TRANSMISSION. The autobaud package supports two methods for echoing characters or transmitting characters. The two methods are automatic echo and smart echo.

4.3.9.8.1 Automatic Echo. This method uses the SCC hardware to automatically echo the characters back on the TxD pin. The automatic echo is enabled by setting the DIAG bits in the SCM to '10'. The transmitter should not be enabled. The hardware echo is done automatically. The \overline{CD} pin needs to be asserted in order for the characters to be transmitted back. On SCC1, the external \overline{CD} pin must be tied low. On SCC2 and SCC3, either the external \overline{CD} pin must be tied low or the \overline{CD} pins should be left configured as general purpose input pins (the \overline{CD} signal to the SCC is then connected to ground internally).

Using the automatic echo, the receiver still autobauds correctly and performance is not affected. The SCC echoes the received data with a few nanoseconds delay.

4.3.9.8.2 Smart Echo. This method requires addition hardware and software to implement. The user must provide two clock sources. One clock source is the sample clock which is input on RCLK and cannot be divided down. The BRG is used to divide the second clock down to provide the clock used for transmit. The second clock can be either the system clock or a clock connected to TIN1. The TIN1 and RCLK pins can be connected to each other externally.

After the first character is received, the user must take the following steps:

1. Determine the baud rate from the returned NOM_START value and program SCON to (input frequency/baud rate)-1, where the input frequency is either the system clock or the clock on TIN1.
2. Program the DSR to \$FFFF. The DSR will need to be programmed back to \$7FFF before the Enter_Baud_Hunt command is issued again.
3. Set the ENT bit in the mode register.
4. Program the transmit character BD as show in Table 4-8.

15	14	13	12	11	10	9	8	7	6	5	4	3	2	1	0
R		CL		PE	PM			CHAR							

Table 4-8. Transmit Character BD

R (ready bit)

- 0 = Character is not ready
- 1 = Character is ready to transmit

CL (character len)

- 0 = 7 bits + parity or 8 bits with no parity
- 1 = 8 bits + parity

PE (parity enable)

- 0 = No parity
- 1 = Parity

PM (parity mode)

0 = Even parity

1 = Odd parity

The autobaud controller issues a Tx interrupt after each character is transmitted.

4.3.9.9 REPROGRAMMING TO UART MODE OR ANOTHER PROTOCOL. The following steps should be followed in order to switch the SCC from autobaud to UART mode or to another protocol.

- Disable the SCC by clearing ENR and ENT.
- Issue the Enter_Hunt_Mode command.
- Initialize the SCC parameter RAM (specifically, the Rx and Tx internal states and the words containing the Rx and Tx BD#s) to the state immediately after reset and initialize the protocol specific parameter area for the new protocol.
- Re-enable the SCC with the new mode.

4.3.10 HDLC Controller

The functionality of the HDLC controller has not changed. For any additional information on parameters, registers, and functionality, please refer to the *MC68302 Users' Manual*.

4.3.10.1 HDLC MEMORY MAP . When configured to operate in HDLC mode, the IMP overlays the structure shown in Table 4-8 onto the protocol-specific area of that SCC parameter RAM. Refer to Parameter RAM on page 21 for the placement of the three SCC parameter RAM areas and to Table 4-1 for the other parameter RAM values.

Table 4-9. HDLC-Specific Parameter RAM

Address	Name	Width	Description
SCC Base + 9C	RCRC_L	Word	Temp Receive CRC Low
SCC Base + 9E	RCRC_H	Word	Temp Receive CRC High
SCC Base + A0 #	C_MASK_L	Word	Constant (\$F0B8 16-Bit CRC, \$DEBB 32-Bit CRC)
SCC Base + A2 #	C_MASK_H	Word	Constant (\$XXXX 16-Bit CRC, \$20E3 32-Bit CRC)
SCC Base + A4	TCRC_L	Word	Temp Transmit CRC Low
SCC Base + A6	TCRC_H	Word	Temp Transmit CRC High
SCC Base + A8 #	DISFC	Word	Discard Frame Counter
SCC Base + AA #	CRCEC	Word	CRC Error Counter
SCC Base + AC #	ABTSC	Word	Abort Sequence Counter
SCC Base + AE #	NMARC	Word	Nonmatching Address Received Counter
SCC Base + B0 #	RETRC	Word	Frame Retransmission Counter
SCC Base + B2 #	MFLR	Word	Max Frame Length Register
SCC Base + B4	MAX_cnt	Word	Max_Length Counter
SCC Base + B6 #	HMASK	Word	User-Defined Frame Address Mask
SCC Base + B8 #	HADDR1	Word	User-Defined Frame Address
SCC Base + BA #	HADDR2	Word	User-Defined Frame Address
SCC Base + BC #	HADDR3	Word	User-Defined Frame Address
SCC Base + BE #	HADDR4	Word	User-Defined Frame Address

Should be initialized by the user (M68000 core).

4.3.10.2 HDLC MODE REGISTER . Each SCC mode register is a 16-bit, memory-mapped, read-write register that controls the SCC operation. The read-write HDLC mode register is cleared by reset.

15	14	13	12	11	10	9	8	7	6	5	0			
NOF3	NOF2	NOF1	NOF0	C32	FSE	—	RTE	FLG	ENC	COMMON SCC MODE BITS				

4.3.10.3 HDLC RECEIVE BUFFER DESCRIPTOR (RX BD) . The HDLC controller uses the Rx BD to report information about the received data for each buffer. The Rx BD is shown in Figure 4-4.

	15	14	13	12	11	10	9	8	7	6	5	4	3	2	1	0
OFFSET + 0	E	X	W	I	L	F	—	—	—	—	LG	NO	AB	CR	OV	CD
OFFSET + 2	DATA LENGTH															
OFFSET + 4	RX BUFFER POINTER (24-bits used, upper 8 bits must be 0)															
OFFSET + 6																

Figure 4-4. HDLC Receive Buffer Descriptor

4.3.10.4 HDLC TRANSMIT BUFFER DESCRIPTOR (TX BD) . Data is presented to the HDLC controller for transmission on an SCC channel by arranging it in buffers referenced by the channel's Tx BD table. The Tx BD is shown in Figure 4-5.

	15	14	13	12	11	10	9	8	7	6	5	4	3	2	1	0
OFFSET + 0	R	X	W	I	L	TC	—	—	—	—	—	—	—	—	UN	CT
OFFSET + 2	DATA LENGTH															
OFFSET + 4	TX BUFFER POINTER (24-bits used, upper 8 bits must be 0)															
OFFSET + 6																

Figure 4-5. HDLC Transmit Buffer Descriptor

4.3.10.5 HDLC EVENT REGISTER . The SCC event register (SCCE) is called the HDLC event register when the SCC is operating as an HDLC controller. It is an 8-bit register used to report events recognized by the HDLC channel and to generate interrupts. Upon recognition of an event, the HDLC controller sets its corresponding bit in the HDLC event register. Interrupts generated by this register may be masked in the HDLC mask register. A bit is cleared by writing a one; writing a zero does not affect a bit's value. All unmasked bits must be cleared before the CP will clear the internal interrupt request. This register is cleared at reset.

7	6	5	4	3	2	1	0
CTS	CD	IDL	TXE	RXF	BSY	TXB	RXB

4.3.10.6 HDLC MASK REGISTER. The SCC mask register (SCCM) is referred to as the HDLC mask register when the SCC is operating as an HDLC controller. It is an 8-bit read-write register that has the same bit formats as the HDLC event register. If a bit in the HDLC mask register is a one, the corresponding interrupt in the event register will be enabled. If the bit is zero, the corresponding interrupt in the event register will be masked. This register is cleared upon reset.

4.3.11 BISYNC Controller

The functionality of the BISYNC controller has not changed. For any additional information on parameters, registers, and functionality, please refer to the *MC68302 Users' Manual*.

4.3.11.1 BISYNC MEMORY MAP. When configured to operate in BISYNC mode, the IMP overlays the structure listed in Table 4-10 onto the protocol-specific area of that SCC parameter RAM. Refer to System Configuration Registers on page 5 for the placement of the three SCC parameter RAM areas and Table 4-1 for the other parameter RAM values.

Table 4-10. BISYNC Specific Parameter RAM

Address	Name	Width	Description
SCC Base + 9C	RCRC	Word	Temp Receive CRC
SCC Base + 9E	CRCC	Word	CRC Constant
SCC Base + A0 #	PRCRC	Word	Preset Receiver CRC 16/LRC
SCC Base + A2	TCRC	Word	Temp Transmit CRC
SCC Base + A4 #	PTCRC	Word	Preset Transmitter CRC 16/LRC
SCC Base + A6	RES	Word	Reserved
SCC Base + A8	RES	Word	Reserved
SCC Base + AA #	PAREC	Word	Receive Parity Error Counter
SCC Base + AC #	BSYNC	Word	BISYNC SYNC Character
SCC Base + AE #	BDLE	Word	BISYNC DLE Character
SCC Base + B0 #	CHARACTER1	Word	CONTROL Character 1
SCC Base + B2 #	CHARACTER2	Word	CONTROL Character 2
SCC Base + B4 #	CHARACTER3	Word	CONTROL Character 3
SCC Base + B6 #	CHARACTER4	Word	CONTROL Character 4
SCC Base + B8 #	CHARACTER5	Word	CONTROL Character 5
SCC Base + BA #	CHARACTER6	Word	CONTROL Character 6
SCC Base + BC #	CHARACTER7	Word	CONTROL Character 7
SCC Base + BE #	CHARACTER8	Word	CONTROL Character 8

Initialized by the user (M68000 core).

4.3.11.2 BISYNC MODE REGISTER. Each SCC mode register is a 16-bit, memory-mapped, read-write register that controls the SCC operation. The term BISYNC mode register refers to the protocol-specific bits (15–6) of the SCC mode register when that SCC is configured for BISYNC. The read-write BISYNC mode register is cleared by reset.

15	14	13	12	11	10	9	8	7	6	5	0
PM	EXSYN	NTSYN	REVD	BCS	—	RTR	RBCS	SYNF	ENC	COMMON SCC MODE BITS	

4.3.11.3 BISYNC RECEIVE BUFFER DESCRIPTOR (RX BD). The CP reports information about the received data for each buffer using BD. The Rx BD is shown in Figure 4-6

	15	14	13	12	11	10	9	8	7	6	5	4	3	2	1	0
OFFSET+0	E	X	W	I	C	B	—	—	—	—	—	DL	PR	CR	OV	CD
OFFSET+2	DATA LENGTH															
OFFSET+4	RX BUFFER POINTER (24-bits used, upper 8 bits must be 0)															
OFFSET+6																

Figure 4-6. BISYNC Receive Buffer Descriptor

4.3.11.4 BISYNC TRANSMIT BUFFER DESCRIPTOR (TX BD). Data is presented to the CP for transmission on an SCC channel by arranging it in buffers referenced by the channel's Tx BD table. The Tx BD is shown in Figure 4-7.

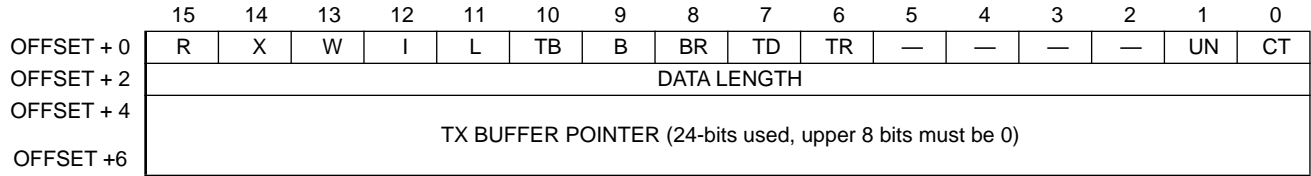
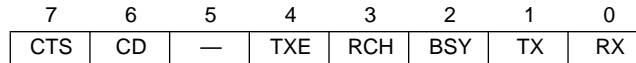

Figure 4-7. BISYNC Transmit Buffer Descriptor

4.3.11.5 BISYNC EVENT REGISTER. The SCC event register (SCCE) is referred to as the BISYNC event register when the SCC is programmed as a BISYNC controller. It is an 8-bit register used to report events recognized by the BISYNC channel and to generate interrupts. On recognition of an event, the BISYNC controller sets the corresponding bit in the BISYNC event register. Interrupts generated by this register may be masked in the BISYNC mask register. A bit is cleared by writing a one. More than one bit may be cleared at a time. All unmasked bits must be cleared before the CP will negate the internal interrupt request signal. This register is cleared at reset.



4.3.11.6 BISYNC MASK REGISTER. The SCC mask register (SCCM) is referred to as the BISYNC mask register when the SCC is operating as a BISYNC controller. It is an 8-bit read-write register that has the same bit format as the BISYNC event register. If a bit in the BISYNC mask register is a one, the corresponding interrupt in the event register will be enabled. If the bit is zero, the corresponding interrupt in the event register will be masked. This register is cleared upon reset.

4.3.12 Transparent Controller

The functionality of the BISYNC controller has not changed. For any additional information on parameters, registers, and functionality, please refer to the *MC68302 Users' Manual*.

4.3.12.1 TRANSPARENT MEMORY MAP. When configured to operate in transparent mode, the IMP overlays the structure illustrated in Table 4-11 onto the protocol specific area of that SCC parameter RAM. Refer to Table 2-6 for the placement of the three SCC parameter RAM areas and Table 4-1 for the other parameter RAM values.

Table 4-11. Transparent-Specific Parameter RAM

Address	Name	Width	Description
SCC BASE + 9C	RES	WORD	Reserved
SCC BASE + 9E	RES	WORD	Reserved
SCC BASE + A0	RES	WORD	Reserved
SCC BASE + A2	RES	WORD	Reserved
SCC BASE + A4	RES	WORD	Reserved
SCC BASE + A6	RES	WORD	Reserved
SCC BASE + A8	RES	WORD	Reserved
SCC BASE + AA	RES	WORD	Reserved
SCC BASE + AC	RES	WORD	Reserved
SCC BASE + AE	RES	WORD	Reserved
SCC BASE + B0	RES	WORD	Reserved
SCC BASE + B2	RES	WORD	Reserved
SCC BASE + B4	RES	WORD	Reserved
SCC BASE + B6	RES	WORD	Reserved
SCC BASE + B8	RES	WORD	Reserved
SCC BASE + BA	RES	WORD	Reserved
SCC BASE + BC	RES	WORD	Reserved
SCC BASE + BE	RES	WORD	Reserved

4.3.12.2 TRANSPARENT MODE REGISTER. Each SCC mode register is a 16-bit, memory-mapped, read-write register that controls the SCC operation. The term transparent mode register refers to the protocol-specific bits (15–6) of the SCC mode register when that SCC is configured for transparent mode. The transparent mode register is cleared by reset. All undefined bits should be written with zero.

15	14	13	12	11	10	9	8	7	6	5	0
—	EXSYN	NTSYN	REVD	—	—	—	—	—	—	COMMON SCC MODE BITS	

4.3.12.3 TRANSPARENT RECEIVE BUFFER DESCRIPTOR (RXBD). The CP reports information about the received data for each buffer using BD. The RxBD is shown in Figure 4-8.

	15	14	13	12	11	10	9	8	7	6	5	4	3	2	1	0
OFFSET + 0	E	X	W	I	—	—	—	—	—	—	—	—	—	—	OV	CD
OFFSET + 2	DATA LENGTH															
OFFSET + 4	RX BUFFER POINTER (24-bits used, upper 8 bits must be 0)															
OFFSET + 6																

Figure 4-8. Transparent Receive Buffer Descriptor

4.3.12.4 TRANSPARENT TRANSMIT BUFFER DESCRIPTOR (TX BD) . Data is presented to the CP for transmission on an SCC channel by arranging it in buffers referenced by the channel's Tx BD table. The Tx BD is shown in Figure 4-9.

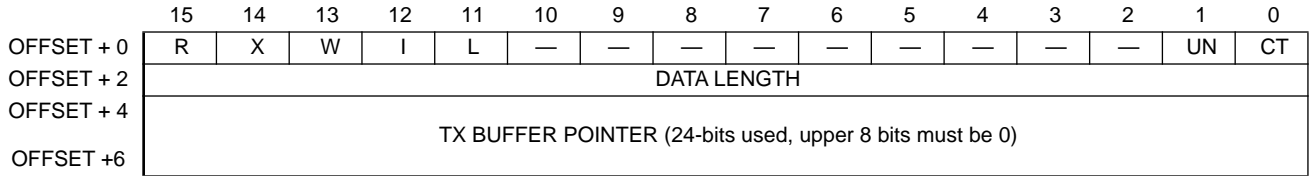
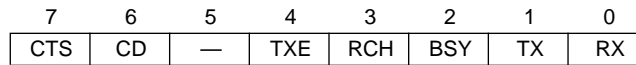

Figure 4-9. Transparent Transmit Buffer Descriptor

4.3.12.5 TRANSPARENT EVENT REGISTER . The SCC event register (SCCE) is referred to as the transparent event register when the SCC is programmed as a transparent controller. It is an 8-bit register used to report events recognized by the transparent channel and to generate interrupts. On recognition of an event, the transparent controller sets the corresponding bit in the transparent event register. A bit is cleared by writing a one (writing a zero does not affect a bit's value). This register is cleared at reset.



4.3.12.6 TRANSPARENT MASK REGISTER . The SCC mask register (SCCM) is referred to as the transparent mask register when the SCC is operating as a transparent controller. It is an 8-bit read-write register that has the same bit format as the transparent event register. If a bit in the transparent mask register is a one, the corresponding interrupt in the event register will be enabled. If the bit is zero, the corresponding interrupt in the event register will be masked. This register is cleared at reset.

4.4 SERIAL COMMUNICATION PORT (SCP)

The functionality of the SCP has not changed. For any additional information on parameters, registers, and functionality, please refer to the *MC68302 Users' Manual*.

4.4.1 SCP Programming Model

The SCP mode register consists of the upper eight bits of SPMODE. The SCP mode register, an internal read-write register that controls both the SCP operation mode and clock source, is cleared by reset.

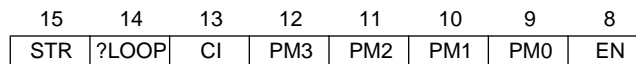

4.4.2 SCP Transmit/Receive Buffer Descriptor

The transmit/receive BD contains the data to be transmitted (written by the M68000 core) and the received data (written by the SCP). The done (D) bit indicates that the received data is valid and is cleared by the SCP.

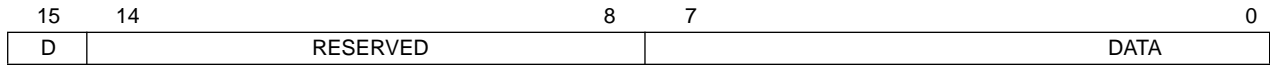

4.5 SERIAL MANAGEMENT CONTROLLERS (SMCS)

The functionality of the SMCs has not changed. For any additional information on parameters, registers, and functionality, please refer to the *MC68302 Users' Manual*.

4.5.1 SMC Programming Model

The operating mode of both SMC ports is defined by SMC mode, which consists of the lower eight bits of SPMODE. As previously mentioned, the upper eight bits program the SCP.

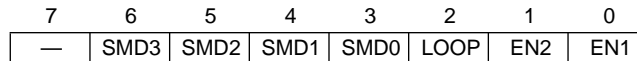

4.5.2 SMC Memory Structure and Buffers Descriptors

The CP uses several memory structures and memory-mapped registers to communicate with the M68000 core. All the structures detailed in the following paragraphs reside in the dual-port RAM of the IMP. The SMC buffer descriptors allow the user to define one data byte at a time for each transmit channel and receive one data byte at a time for each receive channel.

4.5.2.1 SMC1 RECEIVE BUFFER DESCRIPTOR. The CP reports information about the received byte using this (BD).

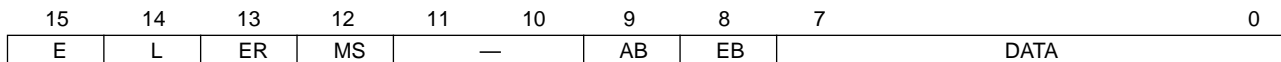

4.5.2.2 SMC1 TRANSMIT BUFFER DESCRIPTOR. The CP reports information about this transmit byte through the BD.

	15	14	13	12	10	9	8	7		0
	R	L	AR	—		AB	EB			DATA

4.5.2.3 SMC2 RECEIVE BUFFER DESCRIPTOR. In the IDL mode, this BD is identical to the SMC1 receive BD. In the GCI mode, SMC2 is used to control the C/I channel.

	15	14			6	5		2	1	0
	E		RESERVED					C/I	0	0

4.5.2.4 SMC2 TRANSMIT BUFFER DESCRIPTOR. In the IDL mode, this BD is identical to the SMC1 transmit BD. In the GCI mode, SMC2 is used to control the C/I channel.

	15	14			6	5		2	1	0
	R		RESERVED					C/I	0	0

SECTION 5 SIGNAL DESCRIPTION

This section defines the MC68LC302 pinout. The input and output signals of the MC68LC302 are organized into functional groups and are described in the following sections. The MC68LC302 is offered in a 100-lead thin quad flat package (TQFP) and a 132-pin (13 x 13) pin grid array (PGA) for emulator applications.

The MC68LC302 uses a M68000 like bus for communication between both on-chip and external peripherals. This bus is a single, continuous bus existing both on-chip and off-chip the MC68LC302. Any access made internal to the device is visible externally. Any access made external is visible internally. Thus, when the M68000 core accesses the dual-port RAM, the bus signals are driven externally. Likewise, in disable CPU mode, when an external device accesses an area of external system memory, the chip-select logic can be used to generate the chip-select signal and \overline{DTACK} .

5.1 FUNCTIONAL GROUPS

The input and output signals of the MC68LC302 are organized into functional groups as shown in Table 5-1 and Figure 5-1.

Table 5-1. Signal Definitions (TQFP)

Functional Group	Signals	Number
Clocks	XTAL, EXTAL, XFC, CLKO, VCCSYN	5
System Control	RESET, HALT, BUSW, DISCPU	4
Address Bus	A19–A1	19
Data Bus/PNIO	PN15–PN8/D15–D8	8
Data Bus	D7–D0	8
Bus Control	\overline{AS} , \overline{OE} (R/W), WEH($\overline{UDS/A0}$), \overline{WEL} (LDS/DS), \overline{DTACK}	5
Interrupt Control (Bus Arbitration)	$\overline{IPL2}$ – $\overline{IPL0}$ (BR, BG, BGACK)	3
NMSI1/ISDN I/F	RXD1, TXD1, RCLK1, TCLK1, $\overline{CD1}$, $\overline{CTS1}$, $\overline{RTS1}$	7
NMSI2/PAIO	RXD2, TXD2, RCLK2, TCLK2, $\overline{CD2}$, $\overline{CTS2}$, $\overline{RTS2}$, BRG2	8
PAIO/SCP	SPRXD, SPTXD, SPCLK, MODCLK/PA12	4
Timer/PBIO	TIN1, TIN2, TOUT2, WDOG	4
PBIO	PB11–PB8	4
Chip Select	CS3–CS0	4
V _{DD}		6
GND		11

Signal Description

All pins except EXTAL, CLKO, and the layer 1 interface pins in IDL mode support TTL levels. EXTAL, when used as an input clock, needs a CMOS level. CLKO supplies a CMOS level output. The IDL interface is specified as a CMOS electrical interface.

All outputs (except CLKO and the GCI pins) drive 100 pF. CLKO is designed to drive 50 pF. The GCI output pins drive 100 pF.

5.2 POWER PINS

The LC302 (TQFP) has 17 power supply pins. Careful attention has been paid to reducing LC302 noise, potential crosstalk, and RF radiation from the output drivers. Inputs may be +5 V when V_{DD} is 0 V without damaging the device.

- V_{DD} (6)—There are 6 power pins.
- GND (11)—There are 11 ground pins.

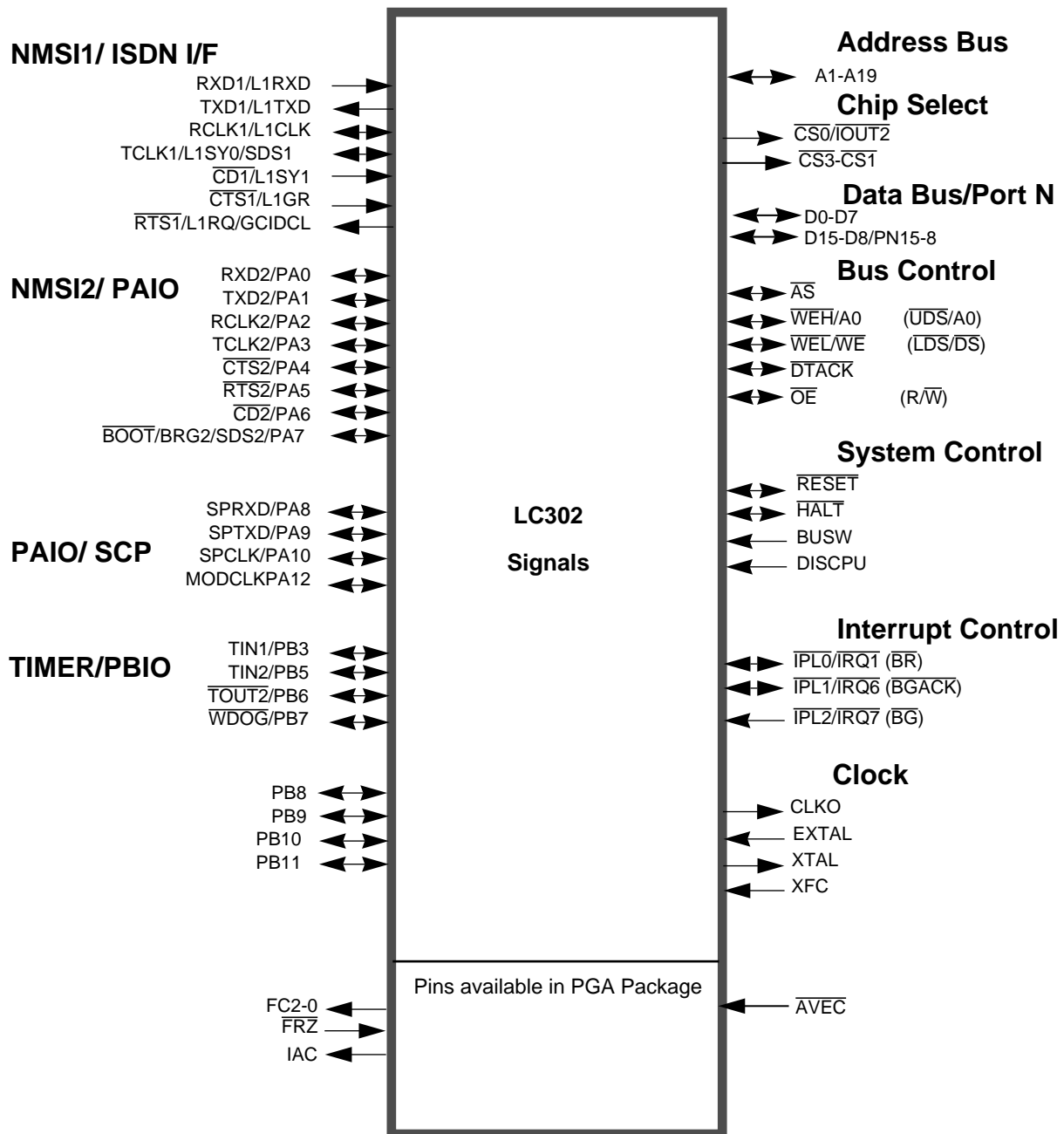

Note: Pins in parenthesis () are available in slave mode only.

Figure 5-1. LC 302 Functional Signal Groups

5.3 CLOCK PINS

The clock pins are shown in Figure 5-2.

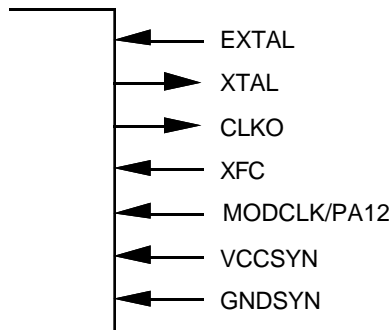

Figure 5-2. Clock Pins

EXTAL—External Clock/Crystal Input

This input provides two clock generation options (crystal and external clock). EXTAL may be used (with XTAL) to connect an external crystal to the on-chip oscillator and clock generator. If an external clock is used, the clock source should be connected to EXTAL, and XTAL should be left unconnected. The oscillator uses an internal frequency equal to the external crystal frequency. The frequency of EXTAL may range from 0 MHz to the Maximum Operating Frequency (25MHz at the time this manual was written). When an external clock is used, it must provide a CMOS level at this input frequency.

The frequency range of the original MC68LC302 is 0 MHz to the Maximum Operating Frequency. In this manual, many references to the frequency “16.67 MHz” are made when the maximum operating frequency of the MC68LC302 is discussed. When using faster versions of the MC68LC302, such as 20 MHz, all references to 16.67 MHz may be replaced with 20. Note, however, that resulting parameters such as baud rates and timer periods change accordingly.

XTAL—Crystal Output

This output connects the on-chip oscillator output to an external crystal. If an external clock is used, XTAL should be left unconnected.

CLKO—Clock Out

This output clock signal is derived from the on-chip clock oscillator. This clock signal is internally connected to the clock input of the M68000 core, the communication processor, and system integration block. All M68000 bus timings are referenced to the CLKO signal. CLKO supports both CMOS and TTL output levels. The output drive capability of the CLKO signal is programmable to one-third, two-thirds, or full strength, or this output can be disabled.

XFC—IMP External Filter Capacitor

This pin is a connection for an external capacitor to filter the PLL.

MODCLK/PA12—Clock Mode Select

The state of this input signal along with VCCSYN during reset selects whether the PLL is enabled and the type of external clock that is used by the phase locked loop (PLL) in the clock synthesizer to generate the system clocks. Table 5-2 shows the default values of the PLL. When the PLL is disabled (VCCSYN=0), this pin functions as PA12. When the PLL is enabled (VCCSYN1), this pin is sampled as MODCLK at reset. This pin must be valid as long as $\overline{\text{RESET}}$ and $\overline{\text{HALT}}$ are asserted, and have a hold time of 5ns after $\overline{\text{RESET}}$ and $\overline{\text{HALT}}$ are negated. After reset, MODCLK/PA12 is a general purpose I/O pin.

Table 5-2. Default Operation Mode of the PLL

VCCSYN	MODCLK	PLL	Multi. Factor (MF+1)	EXTAL Freq. (examples)	CLKIN to the PLL	LC302 System Clock
0	X	Disabled	x	-	=EXTAL	=EXTAL
1	0	Enabled	4	4.192MHz	4.192MHz	16.768 MHz
1	1	Enabled	401	32.768KHz	32.768KHz	13.14 MHz

VCCSYN—Analog PLL Circuit Power

This pin is dedicated to the LC302 analog PLL circuits and determines whether the PLL is enabled or not. When this pin is connected to Vcc, the PLL is enabled, and when this pin is connected to ground, the PLL is disabled. The voltage should be well regulated and the pin should be provided with an extremely low impedance path to the V_{CC} power rail. V_{CCSYN} should be bypassed to GND by a 0.1μF capacitor located as close as possible to the chip package.

GNDSYN—Analog PLL Circuits' Ground

This pin is dedicated to the IMP analog PLL circuits. The pin should be provided with an extremely low impedance path to ground. GNDSYN should be bypassed to VCCSYN by a 0.1μF capacitor located as close as possible to the chip package.

5.4 SYSTEM CONTROL PINS

The system control pins are shown in Figure 5-3.

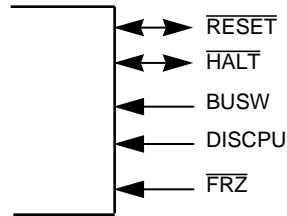

* This pin is available in PGA Package only

Figure 5-3. System Control Pins

RESET

This bidirectional, open-drain signal, acting as an input and asserted along with the $\overline{\text{HALT}}$ pin, starts an initialization sequence called a total system reset that resets the entire MC68LC302. $\overline{\text{RESET}}$ and $\overline{\text{HALT}}$ should remain asserted for at least 100 ms at power-on reset, and at least 10 clocks otherwise. The on-chip system RAM is not initialized during reset except for several locations initialized by the CP.

NOTE

With a 32.768Khz external crystal the minimum RESET length is 2.3 seconds

An internally generated reset, from the M68000 RESET instruction, causes the $\overline{\text{RESET}}$ line to become an output for 124 clocks. In this case, the M68000 core is not reset; however, the communication processor is fully reset, and the system integration block is almost fully reset. The user may also use the $\overline{\text{RESET}}$ output signal in this case to reset all external devices.

During a total system reset, the address, data, and bus control pins are all three-stated, except for $\overline{\text{CS3}}-\overline{\text{CS0}}$, $\overline{\text{WEH}}$, $\overline{\text{WEL}}$, and $\overline{\text{OE}}$, which are high, and IAC, which is low. The $\overline{\text{BG}}$ pin output is the same as that on the $\overline{\text{BR}}$ input. The general-purpose I/O pins are configured as inputs, except for $\overline{\text{WDOG}}$, which is an open-drain output. The NMS11 pins are all inputs, except for $\overline{\text{RTS1}}$ and TXD1, which output a high value. CLK0 is active.

Besides the total system reset and the RESET instruction, some of the MC68LC302 peripherals have reset bits in one of their registers that cause that particular peripheral to be reset to the same state as a total system reset or the RESET instruction. Reset bits may be found in the CP (in the CR), the IDMA (in the CMR), timer 1 (in the TMR1), and timer 2 (in the TMR2).

$\overline{\text{HALT}}$ —Halt

When this bidirectional, open-drain signal is driven by an external device, it will cause the LC302 bus master (M68000 core, SDMA, or IDMA) to stop at the completion of the current bus cycle. This signal is asserted with the $\overline{\text{RESET}}$ signal to cause a total MC68LC302 system reset. This signal is also used to force the LC302 off the bus if another bus master

requires the bus, unless the LC302 core is disabled (then the BR, BG, and BGACK pins should be used). After asserting the $\overline{\text{HALT}}$ signal, the external bus master must wait until $\overline{\text{AS}}$ is negated plus 2 additional clocks before accessing the bus (to allow the LC302 to threestate all of the bus signals).

BUSW—Bus Width Select

This input defines the M68000 processor mode (MC68000 or MC68008) and the data bus width (16 bits or 8 bits, respectively). BUSW may only be changed upon a total system reset. In 16-bit mode, all accesses to internal and external memory by the MC68000 core, the IDMA, SDMA, and external master may be 16 bits, according to the assertion of the UDS and LDS pins. In 8-bit mode, all M68000 core and IDMA accesses to internal and external memory are limited to 8 bits. Also in 8-bit mode, SDMA accesses to external memory are limited to 8 bits, but CP accesses to the CP side of the dual-port RAM continue to be 16 bits. In 8-bit mode, external accesses to internal memory are also limited to 8 bits at a time.

Low = 8-bit data bus, MC68008 core processor

High = 16-bit data bus, MC68000 core processor

DISCPU—Disable CPU (M68000 core)

The MC68LC302 can be configured to work solely with an external CPU. In this mode the on-chip M68000 core CPU should be disabled by asserting the DISCPU pin high during a total system reset ($\overline{\text{RESET}}$ and $\overline{\text{HALT}}$ asserted). DISCPU may only be changed upon a total system reset.

The DISCPU pin, for instance, allows use of several LC302s to provide more than two SCC channels without the need for bus isolation techniques. An external processor services the other LC302s as peripherals (with their respective cores disabled).

$\overline{\text{FRZ}}$

The $\overline{\text{FRZ}}$ pin is used to freeze the activity of selected peripherals. This is useful for system debugging purposes. Refer to 3.1.4 Freeze Control for more details. $\overline{\text{FRZ}}$ should be continuously negated during total system reset.

5.5 ADDRESS BUS PINS (A19–A1)

The address bus pins are shown in Figure 5-4.

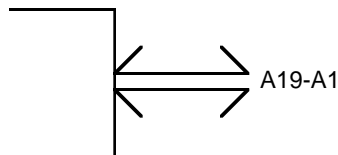

Figure 5-4. Address Bus Pins

A19—A1 form a 20-bit address bus when combined with $\overline{WEH}/\overline{UDS}$. The address bus is a bidirectional, three-state bus capable of addressing 1M bytes of data (including the LC302 internal address space). It provides the address for bus operation during all cycles except CPU space cycles. In CPU space cycles, the CPU reads a peripheral device vector number.

These lines are outputs when the LC302 (M68000 core, SDMA or IDMA) is the bus master and are inputs otherwise (in DISCPU only).

NOTE:

Since internally the CS logic compares also A23-A20 the effective address space for internal masters is 4 M bytes.

5.6 DATA BUS PINS (D15—D0)

The data bus pins are shown in Figure 5-5. When the MC68LC302 is in 8-bit data bus mode, D15-D8 become general purpose I/O pins, PN15-PN8.

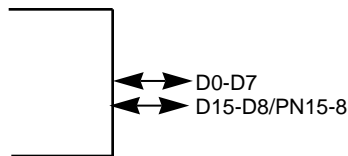

Figure 5-5. Data Bus Pins

This 16-bit, bidirectional, three-state bus is the general-purpose data path. It can transmit and accept data in either word or byte lengths. For all 16-bit LC302 accesses, byte 0, the high-order byte of a word, is available on D15—D8, conforming to the standard M68000 format.

When working with an 8-bit bus (BUSW is low), the data is transferred through the low-order byte (D7—D0). The high-order byte (D15—D8) is not used for data transfer, and those pins can be used as 8 general purpose I/O ports (PNIO).

5.7 BUS CONTROL PINS

The bus control pins are shown in Figure 5-6. The signals shown in parentheses are only available in DISCPU mode.

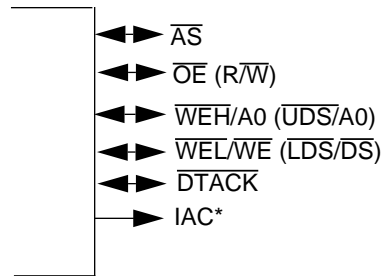

* This pin is available in PGA Package only

Figure 5-6. Bus Control Pins

\overline{AS} —Address Strobe

This bidirectional signal indicates that there is a valid address on the address bus. This line is an output when the LC302 (M68000 core, SDMA or IDMA) is the bus master and is an input otherwise.

\overline{OE} (R/W)— Output Enable (Read/Write)

When the core is enabled, this output is active during a read cycle and indicates that an external device should place valid data on the bus.

When the LC302 is in Disable CPU mode, this bidirectional signal defines the data bus transfer as a read or write cycle. It is an output when the LC302 is the bus master and is an input otherwise.

\overline{WEH} ($\overline{UDS/A0}$)—Write Enable High (Upper Data Strobe/Address 0)

When the core is enabled with a 16-bit data bus, this output pin functions as \overline{WEH} and is active during a write cycle to indicate that an external device should expect data on the D15-D8 of the data bus.

When the core is enabled with a 8-bit data bus, this bidirectional pin functions as A0.

When the LC302 is in Disable CPU mode, this bidirectional line functions as \overline{UDS} and controls the flow of data on the data bus. When using a 16-bit data bus, this pin functions as an upper data strobe (\overline{UDS}). When using an 8-bit data bus, this pin functions as A0.

When used as A0 (i.e., the BUSW pin is low), then the pin takes on the timing of the other address pins, as opposed to the strobe timing. This line is an output when the LC302 is the bus master and is an input otherwise.

\overline{WEL} ($\overline{LDS/DS}$)—Write Enable Low (Lower Data Strobe/Data Strobe)

When the core is enabled, this output pin functions as \overline{WEL} and is active during a write cycle to indicate that an external device should expect data on the D7-D0 of the data bus.

When the LC302 is in Disable CPU mode, this bidirectional line functions as \overline{LDS} and controls the flow of data on the data bus. When using a 16-bit data bus, this pin functions as lower data strobe (\overline{LDS}). When using an 8-bit data bus, this pin functions as \overline{DS} . This line is an output when the LC302 (M68000 core, SDMA or IDMA) is the bus master and is an input otherwise.

\overline{DTACK} —Data Transfer Acknowledge

This bidirectional signal indicates that the data transfer has been completed. \overline{DTACK} can be generated internally in the chip-select logic either for an LC302 bus master or for an external bus master access to an external address within the chip-select ranges. It will also be generated internally during any access to the on-chip dual-port RAM or internal registers. If \overline{DTACK} is generated internally, then it is an output. It is an input when the LC302 accesses an external device not within the range of the chip-select logic or when programmed to be generated externally.

IAC—Internal Access

The IAC signal is only available in the PGA package. This output indicates that the current bus cycle accesses an on-chip location. This includes the on-chip 4K byte block of internal RAM and registers (both real and reserved locations), and the system configuration registers (\$0F0–\$0FF). The above-mentioned bus cycle may originate from the M68000 core, the IDMA, or an external bus master. Note that, if the SDMA accesses the internal dual-port RAM, it does so without arbitration on the M68000 bus; therefore, the IAC pin is not asserted in this case. The timing of IAC is identical to that of the $\overline{CS3}$ – $\overline{CS0}$ pins.

5.8 BUS ARBITRATION PINS

The bus arbitration pins are shown in Figure 5-7. **These signals are only available in disable CPU mode. When the core is enabled, the bus arbitration signals are the IPL2-0 signals.**

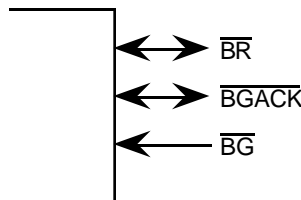

Figure 5-7. Bus Arbitration Pins

\overline{BR} —Bus Request

This input signal indicates to the on-chip bus arbiter that an external device desires to become the bus master.

$\overline{\text{BG}}$ —Bus Grant

This signal is an input to the IDMA and SDMA when the internal M68000 core is disabled and indicates that the LC302 has the bus after the current bus cycle completes.

 $\overline{\text{BGACK}}$ —Bus Grant Acknowledge

This bidirectional signal indicates that some device has become the bus master. This signal is an input when an external device owns the bus. This signal is an output when the IDMA or SDMA has become the master of the bus. If the SDMA steals a cycle from the IDMA, the $\overline{\text{BGACK}}$ pin will remain asserted continuously.

NOTE

$\overline{\text{BGACK}}$ should always be used in the external bus arbitration process.

5.9 INTERRUPT CONTROL PINS

The interrupt control pins are shown in Figure 5-8. **The $\overline{\text{IPL2-0}}$ signals are only available when the CPU is enabled. The FC2-0 and $\overline{\text{AVEC}}$ signals are only available in the PGA package.**

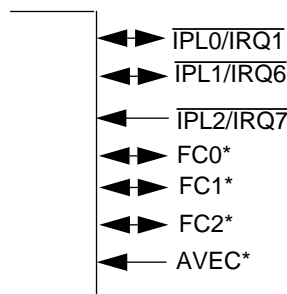

* Those pins are available in PGA Package only

Figure 5-8. Interrupt Control Pins

These inputs have dual functionality:

- $\overline{\text{IPL0/IRQ1}}$
- $\overline{\text{IPL1/IRQ6}}$
- $\overline{\text{IPL2/IRQ7}}$ —Interrupt Priority Level 2–0/Interrupt Request 1,6,7

As $\overline{\text{IPL2-IPL0}}$ (normal mode), these input pins indicate the encoded priority level of the external device requesting an interrupt. Level 7 is the highest (nonmaskable) priority; whereas, level 0 indicates that no interrupt is requested. The least significant bit is $\overline{\text{IPL0}}$, and the most significant bit is $\overline{\text{IPL2}}$. These lines must remain stable until the M68000 core

signals an interrupt acknowledge through A19–A16 to ensure that the interrupt is properly recognized.

As $\overline{\text{IRQ1}}$, $\overline{\text{IRQ6}}$, and $\overline{\text{IRQ7}}$ (dedicated mode), these inputs indicate to the MC68LC302 that an external device is requesting an interrupt. Level 7 is the highest level and cannot be masked. Level 1 is the lowest level. Each one of these inputs (except for level 7) can be programmed to be either level-sensitive or edge-sensitive. The M68000 always treats a level 7 interrupt as edge sensitive.

FC2–FC0—Function Codes 2–0

These bidirectional signals indicate the state and the cycle type currently being executed. The information indicated by the function code outputs is valid whenever $\overline{\text{AS}}$ is active.

These lines are outputs when the IMP (M68000 core, SDMA, or IDMA) is the bus master and are inputs otherwise. The function codes output by the M68000 core are predefined; whereas, those output by the SDMA and IDMA are programmable. The function code lines are inputs to the chip-select logic and IMP internal register decoding in the BAR.

$\overline{\text{AVEC}}$ —Autovector Input/Interrupt Output

In normal operation, this signal functions as the input $\overline{\text{AVEC}}$. $\overline{\text{AVEC}}$, when asserted during an interrupt acknowledge cycle, indicates that the M68000 core should use automatic vectoring for an interrupt. This pin operates like $\overline{\text{VPA}}$ on the MC68000, but is used for automatic vectoring only. $\overline{\text{AVEC}}$ instead of $\overline{\text{DTACK}}$ should be asserted during autovectoring and should be high otherwise.

5.10 MC68LC302 BUS INTERFACE SIGNAL SUMMARY

Table 5-3 and Table 5-4 summarize all bus signals discussed in the previous paragraphs. They show the direction of each pin for the following bus masters: M68000 core, IDMA, SDMA (includes DRAM refresh), and external bus masters. When the core is enabled, only the LC302 core has access to the internal memory. When the core is disabled, the IDMA, SDMA, and external bus masters can access either internal dual-port RAM and registers or an external device or memory. When an external bus master accesses the internal dual-port RAM or registers, the access may be synchronous or asynchronous.

External masters are only directly supported in the Disable CPU mode. When the core is enabled and an external bus master needs the bus, then the $\overline{\text{HALT}}$ pin must be asserted to the LC302 to halt the part.

Table 5-3. Bus Signal Summary—Core and External Master

Signal Name ²	Pin Type	M68000 Core Master Access To		External Master Access To ¹	
		Internal Memory Space	External Memory Space	Internal Memory Space	External Memory Space
A19–A1, \overline{AS} , \overline{UDS} , \overline{LDS} , \overline{RW}	I/O	O	O	I	I
\overline{WEH} , \overline{WEL} , \overline{OE}	I/O	O	O	O*	O*
D15–D0 Read	I/O	O	I	O	I
D15–D0 Write	I/O	O	O	I	I
\overline{DTACK}	I/O	O	**	O	**
$\overline{(BR)}$	I/O Open Drain	NA	NA	N/A	N/A
$\overline{(BG)}$	I	NA	NA	N/A	N/A
$\overline{(BGACK)}$	I/O	NA	NA	I	I
\overline{HALT}	I/O Open Drain	I/O	I/O	I	I
\overline{RESET}	I/O Open Drain	I/O	I/O	I	I
$\overline{IPL2}$ – $\overline{IPL0}$	I	I	I	NA	NA
\overline{AVEC}	I	I	I	I	I
$\overline{IOUT2}$	O	O	O	O	O

¹External Masters are only directly supported in Disable CPU mode.

²Signal Names in parentheses are only available in Disable CPU mode.

* \overline{WEH} , \overline{WEL} , \overline{OE} are threestate when External Master Acquires the Bus with \overline{HALT}

**If \overline{DTACK} is generated automatically (internally) by the chip-select logic, then it is an output. Otherwise, it is an input.

Table 5-4. Bus Signal Summary—IDMA and SDMA

Signal Name ¹	Pin Type	IDMA Master Access To		SDMA Master Access To	
		Internal Memory Space	External Memory Space	Internal Memory Space	External Memory Space
A19–A1, \overline{AS} , \overline{UDS} , \overline{LDS} , \overline{RW}	I/O	O	O	N/A	O
\overline{WEH} , \overline{WEL} , \overline{OE}	I/O	O	O	N/A	O
D15–D0 Read	I/O	O	I	N/A	I
D15–D0 Write	I/O	O	O	N/A	O
\overline{DTACK}	I/O	O	**	N/A	**
$\overline{(BR)}$	I/O	O ##	O ##	N/A	O ##
$\overline{(BG)}$	I/O	I ##	I ##	N/A	I ##
$\overline{(BGACK)}$	I/O	O##	O##	N/A	O##
\overline{HALT}	I/O Open Drain	I	I	N/A	I
\overline{RESET}	I/O Open Drain	I	I	N/A	I

¹ Signal Names in parentheses are only available in Disable CPU mode.

**If \overline{DTACK} is generated automatically (internally) by the chip-select logic, then it is an output. Otherwise, it is an input. #Applies to disable CPU mode only. The internal signal IBCLR is used otherwise.

##Applies to disable CPU mode only, otherwise N/A.

5.11 PHYSICAL LAYER SERIAL INTERFACE PINS

The physical layer serial interface has 18 pins, and all of them have multiple functions. The pins can be used in a variety of configurations in ISDN or non-ISDN environments. Table 5-4 shows the functionality of each group of pins and their internal connection to the two SCCs and one SCP controllers. The physical layer serial interface can be configured for non-multiplexed operation (NMSI) or multiplexed operation that includes IDL, GCI, and PCM highway modes. IDL and GCI are ISDN interfaces. When working in one of the multiplexed modes, the NMSI1/ISDN physical interface can be connected to both SCC controllers.

Table 5-5. Serial Interface Pin Functions

First Function	Connected To	Second Function	Connected To
NMSI1 (7)	SCC1 Controller	ISDN Interface	SCC1/SCC2
NMSI2 (8)	SCC2 Controller	PIO—Port A	Parallel I/O
PAIO/SCP (3)	SCP Controller	PIO—Port A	Parallel I/O

NOTE: Each one of the parallel I/O pins can be configured individually.

5.12 TYPICAL SERIAL INTERFACE PIN CONFIGURATIONS

Table 5-5 shows typical configurations of the physical layer interface pins for an ISDN environment. Table 5-7 shows potential configurations of the physical layer interface pins for a non-ISDN environment. The timer pins can be used in all applications either as dedicated functions or as PIO pins.

Table 5-6. Example ISDN Configuration

Pins	Connected To	Used As
NMSI1 or ISDN I/F	SCC1 and SCC2	SCC1 Used as ISDN D-ch SCC2 Used as ISDN B-ch
PAIO or SCP	PA12–PA8 SCP	PIO or Status/Control Exchange

NOTES:

1. ISDN environment with SCP port for status/control exchange and with existing terminal (for rate adaption).
2. D-ch is used for signaling.
3. B-ch is used for voice (external CODEC required) or for data transfer.

Table 5-7. Typical Generic Configurations

Pins	Connected To	Used As
NMSI1 or ISDN I/F	SCC1	Terminal with Modem
NMSI2	SCC2	Terminal with Modem
PAIO/SCP	SCP	Status/Control Exchange

NOTE: Generic environment with two SCC ports (any protocol) and the SCP port.

5.13 NMSI1 OR ISDN INTERFACE PINS

The NMSI1 or ISDN interface pins are shown in Figure 5-9.

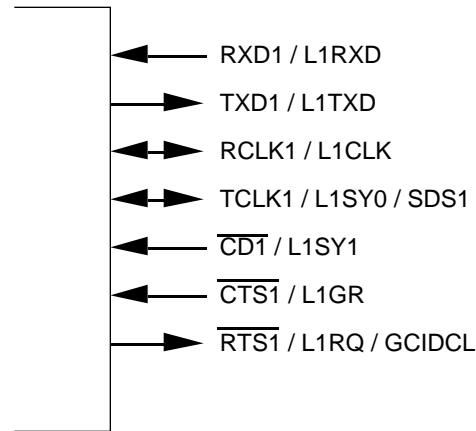

Figure 5-9. NMSI1 or ISDN Interface Pins

These seven pins can be used either as NMSI1 in nonmultiplexed serial interface (NMSI) mode or as an ISDN physical layer interface in IDL, GCI, and PCM highway modes. The input buffers have Schmitt triggers.

Table 5-8 shows the functionality of each pin in NMSI, GCI, IDL, and PCM highway modes.

Table 5-8. Mode Pin Functions

Signal Name	NMSI1		GCI		IDL		PCM	
	I/O	Signal	I/O	Signal	I/O	Signal	I/O	Signal
RXD1/L1RXD	I	RXD1	I	L1RXD	I	L1RXD	I	L1RXD
TXD1/L1TXD	O	TXD1	O	L1TXD	O	L1TXD	O	L1TXD
RCLK1/L1CLK	I/O	RCLK1	I	L1CLK	I	L1CLK	I	L1CLK
TCLK1/L1SY0	I/O	TCLK1	O	SDS1	O	SDS1	I	L1SY0
$\overline{CD1}$ /L1SY1	I	$\overline{CD1}$	I	L1SYNC	I	L1SYNC	I	L1SY1
$\overline{CTS1}$ /L1GR	I	$\overline{CTS1}$	I	L1GR	I	L1GR		
$\overline{RTS1}$ /L1RQ	O	$\overline{RTS1}$	O	GCIDCL	O	L1RQ	O	\overline{RTS}

NOTES:

1. In IDL and GCI mode, SDS2 is output on the PA7 pin.
2. $\overline{CD1}$ may be used as an external sync in NMSI mode.
3. \overline{RTS} is the $\overline{RTS1}$, $\overline{RTS2}$, or $\overline{RTS3}$ pin according to which SCCs are connected to the PCM highway.

RXD1/L1RXD—Receive Data/Layer-1 Receive Data

This input is used as the NMSI1 receive data in NMSI mode and as the receive data input in IDL, GCI, and PCM modes.

TXD1/L1TXD—Transmit Data/Layer-1 Transmit Data

This output is used as NMSI1 transmit data in NMSI mode and as the transmit data output in IDL, GCI, and PCM modes. TXD1 may be configured as an open-drain output in NMSI mode. L1TXD in IDL and PCM mode is a three-state output. In GCI mode, it is an open-drain output.

RCLK1/L1CLK—Receive Clock/Layer-1 Clock

This pin is used as an NMSI1 bidirectional receive clock in NMSI mode or as an input clock in IDL, GCI, and PCM modes. In NMSI mode, this signal is an input when SCC1 is working with an external clock and is an output when SCC1 is working with its baud rate generator.

TCLK1/L1SY0/SDS1—Transmit Clock/PCM Sync/Serial Data Strobe 1

This pin is used as an NMSI1 bidirectional transmit clock in NMSI mode, as a sync signal in PCM mode, or as the SDS1 output in IDL/GCI modes. In NMSI mode, this signal is an input when SCC1 is working with an external clock and is an output when SCC1 is working with its baud rate generator.

NOTE

When using SCC1 in the NMSI mode with the internal baud rate generator operating, the TCLK1 and RCLK1 pins will always output the baud rate generator clock unless disabled in the CKCR register. Thus, if a dynamic selection between an internal and external clock source is required in an application, the clock pins should be disabled first in the CKCR register before switching the TCLK1 and RCLK1 lines. On SCC2, contention may be avoided by disabling the clock line outputs in the PACNT register.

In PCM mode, L1SY1–L1SY0 are encoded signals used to create channels that can be independently routed to the SCCs.

Table 5-9. PCM Mode Signals

L1SY1	L1SY0	Data (L1RXD, L1TXD) is Routed to SCC
0	0	L1TXD is Three-Stated, L1RXD is Ignored
0	1	CH-1
1	0	CH-2
1	1	CH-3

NOTE: CH-1, 2, and 3 are connected to the SCCs as determined in the SIMODE register.

In IDL/GCI modes, the SDS2–SDS1 outputs may be used to route the B1 and/or B2 channels to devices that do not support the IDL or GCI buses. This is configured in the serial interface mode (SIMODE) and serial interface mask (SIMASK) registers.

 $\overline{\text{CD1}}$ /L1SY1—Carrier Detect/Layer-1 Sync

This input is used as the NMSI1 carrier detect ($\overline{\text{CD}}$) pin in NMSI mode, as a PCM sync signal in PCM mode, and as an L1SYNC signal in IDL/GCI modes.

If the $\overline{\text{CD1}}$ pin has changed for more than one receive clock cycle, the LC302 asserts the appropriate bit in the SCC1 event register. If the SCC1 channel is programmed not to support $\overline{\text{CD1}}$ automatically (in the SCC1 mode register), then this pin may be used as an external interrupt source. The current value of $\overline{\text{CD1}}$ may be read in the SCCS1 register. See

MC68302 User's Manual for details. $\overline{CD1}$ may also be used as an external sync in NMSI mode.

$\overline{CTS1}/L1GR$ —Clear to Send/Layer-1 Grant

This input is the NMSI1 \overline{CTS} signal in the NMSI mode or the grant signal in the IDL/GCI mode. If this pin is not used as a grant signal in GCI mode, it should be connected to V_{DD} .

If the $\overline{CTS1}$ pin has changed for more than one transmit clock cycle, the LC302 asserts the appropriate bit in the SCC1 event register and optionally aborts the transmission of that frame.

If SCC1 is programmed not to support $\overline{CTS1}$ (in the SCC1 mode register), then this pin may be used as an external interrupt source. The current value of the $\overline{CTS1}$ pin may be read in the SCCS1 register. See the *MC68302 User's Manual* for details.

$\overline{RTS1}/L1RQ/GCIDCL$ —Request to Send/Layer-1 Request/GCI Clock Out

This output is the NMSI1 \overline{RTS} signal in NMSI mode or PCM Highway mode, the IDL request signal in IDL mode, or the GCI data clock output in GCI mode. In PCM Highway mode, $\overline{RTS1}$ is asserted high.

$\overline{RTS1}$ is asserted when SCC1 (in NMSI mode) has data or pad (flags or syncs) to transmit.

In GCI mode this pin is used to output the GCI data clock.

5.14 NMSI2 PORT OR PORT A PINS

The NMSI2 port or port A pins are shown in Figure 5-10.

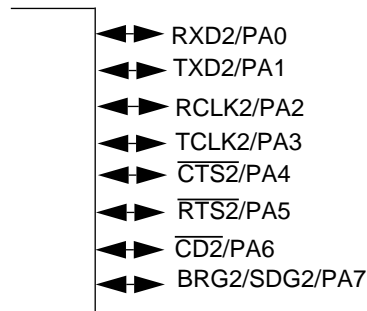

Figure 5-10. NMSI2 Port or Port A Pins

These eight pins can be used either as the NMSI2 port or as a general-purpose parallel I/O port. Each one of these pins can be configured individually to be general-purpose I/O pins or a dedicated function in NMSI2. When they are used as NMSI2 pins, they function exactly as the NMSI1 pins in NMSI mode.

The PA7 signal in dedicated mode becomes serial data strobe 2 (SDS2) in IDL and GCI modes. In IDL/GCI modes, the SDS2–SDS1 outputs may be used to route the B1 and/or B2 channels to devices that do not support the IDL or GCI buses. This is configured in the SI-

MODE and SIMASK registers. If SCC2 is in NMSI mode, this pin operates as BRG2, the output of the SCC2 baud rate generator, unless SDS2 is enabled to be asserted during the B1 or B2 channels of ISDN (bits SDC2–SDC1 of SIMODE). SDS2/BRG2 may be temporarily disabled by configuring it as a general-purpose output pin. The input buffers have Schmitt triggers. TCLK2 acts as the SCC2 baud rate generator output if SCC2 is in one of the multiplexed modes.

- RXD2/PA0
- TXD2/PA1
- RCLK2/PA2
- TCLK2/PA3
- $\overline{\text{CTS2}}$ /PA4
- $\overline{\text{RTS2}}$ /PA5
- $\overline{\text{CD2}}$ /PA6
- $\overline{\text{BOOT}}$ /SDS2/PA7/BRG2

Table 5-10. Baud Rate Generator Outputs

Source	NMSI	GCI	IDL	PCM
SCC2	BRG2	TCLK2	TCLK2	TCLK2

NOTE: In NMSI mode, the baud rate generator outputs can also appear on the RCLK and TCLK pins as programmed in the SCON register.

NOTE

PA7 and PA5 pins are sampled at initialization to determine the boot mode. To enable Boot from SCC2 mode, PA7 has to be pulled LOW during Reset (with 5ns hold time after negation of $\overline{\text{RESET}}$ and $\overline{\text{HALT}}$). If Boot mode is enabled, PA5 determines the Clock source to SCC2. This pin has to be valid for 100 clocks after the negation of $\overline{\text{RESET}}$ and $\overline{\text{HALT}}$. The user can pull it HIGH or LOW with an external resistor. If Boot mode is not enabled PA5 is not sampled at initialization.

5.15 PAIO / SCP PINS

The NMSI3 port or port A pins or SCP pins are shown in Figure 5-11.

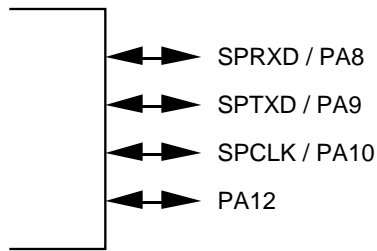

Figure 5-11. PAIO / SCP Pins

These four pins can be used either as the SCP port or parallel I/O pins. If the SCP is enabled (EN bit in SPMODE register is set), then the three lines must be connected to the SCP port by setting the appropriate bits in the Port A Control Register. Otherwise, they are connected to the general purpose I/O.

Three of the port A I/O pins can be configured individually to be general-purpose I/O pins or a SCP pin.

SPRXD/PA8—SCP Receive Serial Data/Port A pin 8

This signal functions as the SCP receive data input or may be used as a general purpose I/O pin.

SPTXD/PA9—SCP Transmit Serial Data/Port A pin 9

This output is the SCP transmit data output or may be used as a general purpose I/O pin.

SPCLK/ $\overline{\text{CD3}}$ —SCP Clock/NMSI3 CD Pin

This bidirectional signal is used as the SCP clock output or may be used as a general purpose I/O pin.

MODCLK/PA12

After Total System Reset this pin functions as bit 12 of port A.

5.16 TIMER PINS

The timer pins are shown in Figure 5-12.

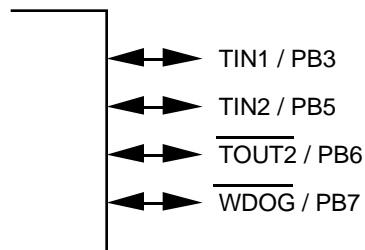

Figure 5-12. Timer Pins

Each of these four pins can be used either as a dedicated timer function or as a general-purpose port B I/O port pin. Note that the timers do not require the use of external pins. The input buffers have Schmitt triggers.

TIN1/PB3—Timer 1 Input

This input is used as a timer clock source for timer 1 or as a trigger for the timer 1 capture register. TIN1 may also be used as the external clock source for any SCC baud rate generators.

TIN2/PB5—Timer 2 Input

This input can be used as a timer clock source for timer 2 or as a trigger for the timer 2 capture register.

TOUT2/PB6—Timer 2 Output

This output is used as an active-low pulse timeout or as an event overflow output (toggle) from timer 2.

WDOG/PB7—Watchdog Output

This active-low, open-drain output indicates expiration of the watchdog timer. WDOG is asserted for a period of 16 clock (CLKO) cycles and may be externally connected to the RESET and HALT pins to reset the MC68LC302. The WDOG pin function is enabled after a total system reset. It may be reassigned as the PB7 I/O pin in the PBCNT register.

5.17 PARALLEL I/O PINS WITH INTERRUPT CAPABILITY

The four parallel I/O pins with interrupt are shown in Figure 5-13.

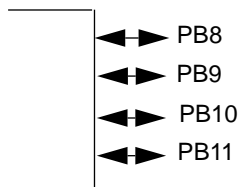

Figure 5-13. Port B Parallel I/O Pins with Interrupt

PB11–PB8—Port B Parallel I/O pins

These four pins may be configured as a general-purpose parallel I/O ports with interrupt capability. Each of the pins can be configured either as an input or an output. When configured as an input, each pin can generate a separate, maskable interrupt on a high-to-low transition. PB8 may also be used to request a refresh cycle from the DRAM refresh controller rather than as an I/O pin. The input buffers have Schmitt triggers.

5.18 CHIP-SELECT PINS

The chip-select pins are shown in Figure 5-14.

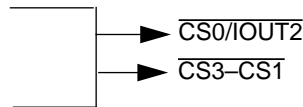

Figure 5-14. Chip-Select Pins

CS0/IOUT2—Chip-Select 0/Interrupt Output 2

In normal operation, this pin functions as CS0. CS0 is one of the four active-low output pins that function as chip selects for external devices or memory. It does not activate on accesses to the internal RAM or registers (including the BAR, SCR, or CKCR registers).

When the M68000 core is disabled, this pin operates as IOUT2. IOUT2 provides the interrupt request output signal from the LC302 interrupt controller to an external CPU when the M68000 core is disabled. This signal is asserted if an internal interrupt of level 4, 6, 7 is generated.

CS3—CS1—Chip Selects 3–1

These three active-low output pins function as chip selects for external devices or memory. CS3—CS0 do not activate on accesses to the internal RAM or registers (including the BAR SCR, or CKCR registers).

5.19 WHEN TO USE PULLUP RESISTORS

Pins that are input-only or output-only do not require external pullups. The bidirectional bus control signals require pullups since they are three-stated by the MC68LC302 when they are not being driven. Open-drain signals always require pullups.

Unused inputs should not be left floating. If they are input-only, they may be tied directly to V_{CC} or ground, or a pullup or pulldown resistor may be used. Unused outputs may be left unconnected. Unused I/O pins may be configured as outputs after reset and left unconnected.

If the MC68LC302 is to be held in reset for extended periods of time in an application (other than what occurs in normal power-on reset or board test sequences) due to a special application requirement (such as V_{DD} dropping below required specifications, etc.), then three-stated signals and inputs should be pulled up or down. This decreases stress on the device transistors and saves power.

See the RESET pin description for the condition of all pins during reset.

SECTION 6

ELECTRICAL CHARACTERISTICS

The AC specifications presented consist of output delays, input setup and hold times, and signal skew times. All signals are specified relative to an appropriate edge of the clock (CLKO pin) and possibly to one or more other signals. The timing for the LC302 signals is the same as the corresponding signals of the 68302.

VERY IMPORTANT NOTE REGARDING SIGNALS

A few signals have been added to and removed from the 68LC302 or their functionality has changed. Several signals are only available when 68302 is in CPU disable mode. The IAC, FC2-FC0, \overline{AVEC} and \overline{FRZ} signals are only available on the PGA package. The A23-A20, \overline{RMC} , \overline{BERR} , \overline{BCLR} , $\overline{IACK1}$, $\overline{IACK6}$, $\overline{IACK7}$, \overline{DREQ} , \overline{DACK} , \overline{DONE} , BRG1, $\overline{TOUT1}$, NC1, NC3, TCLK3, $\overline{RTS3}$, $\overline{CTS3}$, $\overline{CD3}$ signals have been removed. \overline{UDS} , \overline{LDS} , R/W, \overline{BR} , \overline{BG} , \overline{BGACK} are available only in Slave Mode. The following diagrams and tables show the timing for all available signals. For complete information on which signals are available in which modes (CPU disable), please refer to Section 5 of this Addendum.

6.1 MAXIMUM RATINGS

Rating	Symbol	Value	Unit
Supply Voltage	V_{DD}	- 0.3 to + 7.0	V
Input Voltage	V_{in}	- 0.3 to + 7.0	V
Operating Temperature Range MC68302 MC68302C	T_A	0 to 70 - 40 to 85	°C
Storage Temperature Range	T_{stg}	- 55 to + 150	°C

This device contains circuitry to protect the inputs against damage due to high static voltages or electric fields; however, it is advised that normal precautions be taken to avoid application of any voltage higher than maximum-rated voltages to his high-impedance circuit. Reliability of operation is enhanced if unused inputs are tied to an appropriate logic voltage level (e.g., either GND or V_{DD})

6.2 THERMAL CHARACTERISTICS

Characteristic	Symbol	Value	Unit
Thermal Resistance for PGA	θ_{JA}	25	°C/W
	θ_{JC}	2	°C/W
Thermal Resistance for TQFP	θ_{JA}	TBD	°C/W
	θ_{JC}	TBD	°C/W

$$T_J = T_A + (P_D \cdot \theta_{JA})$$

$$P_D = (V_{DD} \cdot I_{DD}) + P_{I/O}$$

where:

$P_{I/O}$ is the power dissipation on pins.

For $T_A = 70^\circ\text{C}$ and $P_{I/O} = 0$ W, 16.67 MHz, 5.5 V, and CQFP package, the worst case value of T_J is:

$$T_J = 70^\circ\text{C} + (5.5 \text{ V} \cdot 30 \text{ mA} \cdot 40^\circ\text{C/W}) = 98.65^\circ\text{C}$$

6.3 POWER CONSIDERATIONS

The average chip-junction temperature, T_J , in °C can be obtained from:

$$T_J = T_A + (P_D \cdot \theta_{JA})(1)$$

where:

$$T_A = \text{Ambient Temperature, } ^\circ\text{C}$$

$$\theta_{JA} = \text{Package Thermal Resistance, Junction to Ambient, } ^\circ\text{C/W}$$

$$P_D = P_{INT} + P_{I/O}$$

$$P_{INT} = I_{DD} \times V_{DD}, \text{ Watts—Chip Internal Power}$$

$$P_{I/O} = \text{Power Dissipation on Input and Output Pins—User Determined}$$

For most applications $P_{I/O} < 0.3 \cdot P_{INT}$ and can be neglected.

If $P_{I/O}$ is neglected, an approximate relationship between P_D and T_J is

$$P_D = K \div (T_J + 273^\circ\text{C})(2)$$

Solving equations (1) and (2) for K gives:

$$K = P_D \cdot (T_A + 273^\circ\text{C}) + \theta_{JA} \cdot P_D^2(3)$$

where K is a constant pertaining to the particular part. K can be determined from equation (3) by measuring P_D (at equilibrium) for a known T_A . Using this value of K, the values of P_D and T_J can be obtained by solving equations (1) and (2) iteratively for any value of T_A .

6.4 POWER DISSIPATION

Characteristic	Symbol	5v Typ	5v Max	Unit
Normal Mode at 20Mhz	PD(I)	70	TBD	mA
Normal Mode at 16Mhz	PD(I)	60	TBD	mA
Low Power Standby Mode	PDSB(I)	7	TBD	mA
Lo Power Doze Mode	PDDZ(I)	500	TBD	μA
Low Power Stop Mode	PDDZ(I)	100	TBD	μA

Note: These values are preliminary estimates. Test values are TBD.

6.5 DC ELECTRICAL CHARACTERISTICS

Characteristic	Symbol	Min	Max	Unit
Input High Voltage (Except pins noted below)	V_{IH}	2.0	V_{DD}	V
Input High Voltage $\overline{CD1}$, $\overline{CTS1}$, $RXD1$, $TXD1$, $RCLK1$, $\overline{RTS1}$, $TCLK1$, $PA7$ - $PA10$, $PA12$, $\overline{CD2}$, $\overline{CTS2}$, $RXD2$, $TXD2$, $RCLK2$, $\overline{RTS2}$, $TCLK2$, $TIN1$, $TIN2$, $TOUT2$, $WDOG$, $PB8$ - $PB11$, \overline{RESET} (These pins have schmitt trigger inputs)	V_{IH}	2.5	V_{DD}	V
Input Low Voltage (Except EXTAL)	V_{IL}	$V_{SS} - 0.3$	0.8	V
Input Undershoot Voltage	V_{CIL}	-	-0.8	V
Input High Voltage (EXTAL) 3.3 Volt or 5 Volt Part	V_{CIH}	$.8 * V_{DD}$	V_{DD}	V
Input Low Voltage (EXTAL)	V_{CIL}	$V_{SS} - 0.3$	0.6	V
Input Leakage Current	I_{IN}	—	20	μA
Input Capacitance All Pins	C_{IN}	—	15	pF
Three-State Leakage Current (2.4/0.5 V)	I_{TSI}	—	20	μA
Open Drain Leakage Current (2.4 V)	I_{OD}	—	20	μA
Output High Voltage ($I_{OH} = 400 \mu A$) (see Note)	V_{OH}	$V_{DD} - 1.0$	—	V
Output Low Voltage ($I_{OL} = 3.2 \text{ mA}$) $A1$ - $A19$, $PB3$ - $PB11$, $\overline{CS0}$ - $\overline{CS3}$ \overline{BG} , $RCLK1$, $RCLK2$, $TCLK1$, $TCLK2$, $\overline{RTS1}$, $\overline{RTS2}$, $SDS2$, $PA12$, $RXD2$, $\overline{CTS2}$, $\overline{CD2}$,	V_{OL}	—	0.5	V
($I_{OL} = 5.3 \text{ mA}$) \overline{AS} , $\overline{WEH}(\overline{UDS})$, $\overline{WEL}(\overline{LDS})$, $\overline{OE}(R/\overline{W})$ \overline{BGACK} , \overline{DTACK} , $D0$ - $D15$, \overline{RESET}		—	0.5	
($I_{OL} = 7.0 \text{ mA}$) $TXD1$, $TXD2$,		—	0.5	
($I_{OL} = 8.9 \text{ mA}$) \overline{HALT} , \overline{BR} (as output)		—	0.5	
($I_{OL} = 3.2 \text{ mA}$) $CLKO$		—	0.4	
Output Drive $CLKO$	O_{CLK}	—	50	pF
Output Drive ISDN I/F (GCI Mode)	O_{GCI}	—	150	pF
Output Drive All Other Pins	O_{ALL}	—	130	pF
Output Drive Derating Factor for $CLKO$ of 0.030 ns/pF	O_{KF}	20	50	pF
Output Drive Derating Factor for $CLKO$ of 0.025 ns/pF	O_{KF}	50	130	pF
Output Drive Derating Factor for All Other Pins 0.025 ns/pF	O_{KF}	20	100	pF
Output Drive Derating Factor for All Other Pins 0.05 ns/pF	O_{KF}	100	200	pF
Power	V_{DD}	4.5 3.0	5.5 3.6	V
Common	V_{SS}	0	0	V

NOTE: The maximum I_{OH} for a given pin is one-half the I_{OL} rating for that pin. For an I_{OH} between 400 μA and $I_{OL}/2$ mA, the minimum V_{OH} is calculated as: $V_{DD} - (1 + 0.05 \text{ V/mA})(I_{OH} - 400 \text{ mA})$.

6.6 DC ELECTRICAL CHARACTERISTICS—NMS11 IN IDL MODE

Characteristic	Symbol	Min	Max	Unit	Condition
Input Pin Characteristics: L1CLK, L1SY1, L1RXD, L1GR					
Input Low Level Voltage	V_{IL}	-10%	+ 20%	V	(% of V_{DD})
Input High Level Voltage	V_{IH}	$V_{DD} - 20\%$	$V_{DD} + 10\%$	V	
Input Low Level Current	I_{IL}	—	± 10	μA	$V_{in} = V_{SS}$
Input High Level Current	I_{IH}	—	± 10	μA	$V_{in} = V_{DD}$
Output Pin Characteristics: L1TXD, SDS1- SDS2, L1RQ					
Output Low Level Voltage	V_{OL}	0	1.0	V	$I_{OL} = 5.0 \text{ mA}$
Output High Level Voltage	V_{OH}	$V_{DD} - 1.0$	V_{DD}	V	$I_{OH} = 400 \mu A$

6.7 AC ELECTRICAL SPECIFICATIONS—CLOCK TIMING

(see Figure 6-1)

Num.	Characteristic	Symbol	16.67 MHz		20 MHz		25 MHz		Unit
			Min	Max	Min	Max	Min	Max	
	System Frequency	f_{sys}	dc	16.67	dc	20.00	dc	25.00	MHz
	Crystal Frequency	f_{XTAL}	25	6000	25	6000	25	6000	kHz
	On-Chip VCO System Frequency	f_{sys}	10	16.67	10	20	10	25	MHz
	Start-up Time With external clock (oscillator disabled) or after changing the multiplication factor MF. With external crystal oscillator enabled.	t_{pll} t_{osc}		2500 75,000		2500 75,000		2500 75,000	clks
	CLKO stability	ΔCLK	TBD	TBD	TBD	TBD	TBD	TBD	%
1	CLKO Period	t_{cyc}	60	-	50	-	40	-	ns
1A	EXTAL Duty Cycle	t_{dcyc}	40	60	40	60	40	60	%
1C	External Clock Input Period	t_{EXTcyc}	60	-	50	-	40	-	ns
2,3	CLKO Pulse width (measured at 1.5v)	t_{cw}	TBD	-	TBD	-	TBD	-	ns
4,5	CLKO Rise and fall times (full drive)	t_{Crf}	-	5	-	4	-	4	ns
5B	EXTAL to CLKO skew (PLL disabled)	t_{EXTP}	2	11	2	9	2	7	ns

Note: The minimum VCO frequency and the PLL default values put some restrictions on the minimum system frequency.

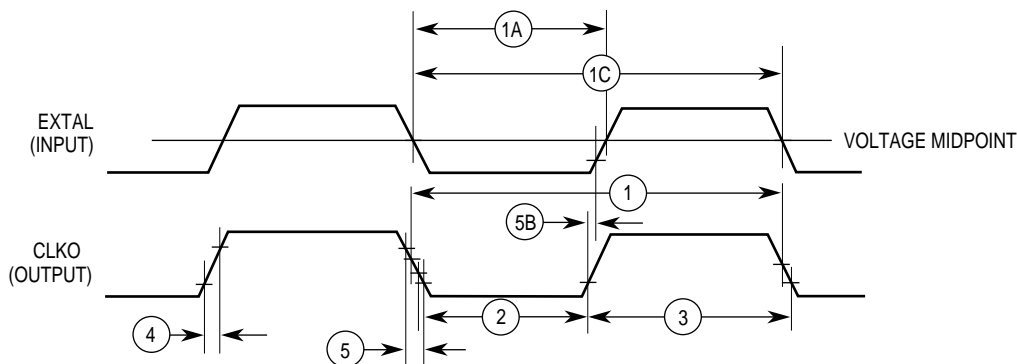

Figure 6-1. Clock Timing Diagram

6.7.1 AC Electrical Characteristics - IMP Phased Lock Loop (PLL) Characteristics

Characteristics	Expression	Min	Max	Unit
VCO frequency when PLL enabled	$MF * Ef$	10	f (Note 1.)	MHz
PLL external capacitor (XFC pin to VCCSYN)	$MF * C_{XFC}$ (Note 1.) @ $MF \leq 5$ @ $MF > 5$	$MF * 340$ $MF * 380$	$MF * 480$ $MF * 970$	pF

1. f is the maximum operating frequency. Ef is EXTERNAL frequency. CXFC is the value of the PLL capacitor (connected between XFC pin and VCCSYN) for MF=1. The recommended value for CXFC is 400pF for MF ≤ 5 and 540pF for MF > 5. The maximum VCO frequency is limited to the internal operation frequency, as defined above.

Examples:

1. MODCK1,0 = 01; MF = 1 fi $340 \leq c_{XFC} \leq 480$ pF

2. MODCK1,0 = 01; crystal is 32.768 KHz (or 4.192 MHz), initial MF = 401, initial frequency = 13.14 MHz; later, MF is changed to 762 to support a frequency of 25 MHz.

Minimum c_{XFC} is: $762 \times 380 = 289$ nF, maximum c_{XFC} is: $401 \times 970 = 390$ nF. The recommended c_{XFC} for 25 MHz is: $762 \times 540 = 414$ nF.

$289 \text{ nF} < c_{XFC} < 390 \text{ nF}$ and closer to 414 nF. The proper available value for c_{XFC} is 390 nF.

3. MODCK1 pin = 1, crystal is 32.768 KHz (or 4.192 MHz), initial MF = 401, initial frequency = 13.14 MHz; later, MF is changed to 1017 to support a frequency of 33.34 MHz.

Minimum c_{XFC} is: $1017 \times 380 = 386$ nF. Maximum c_{XFC} is: $401 \times 970 = 390$ nF $\Rightarrow 386 \text{ nF} < c_{XFC} < 390 \text{ nF}$.

The proper available value for c_{XFC} is 390 nF.

3A. In order to get higher range, higher crystal frequency can be used (i.e. 50 KHz), in this case:

Minimum c_{XFC} is: $667 \times 380 = 253$ nF. Maximum c_{XFC} is: $401 \times 970 = 390$ nF $\Rightarrow 253 \text{ nF} < c_{XFC} < 390$ nF.

6.8 AC ELECTRICAL SPECIFICATIONS—IMP BUS MASTER CYCLES

(see Figure 6-2, Figure 6-3, and Figure 6-4)

Num.	Characteristic	Symbol	16.67 MHz @5.0 V		20 MHz @5.0 V		25 MHz @5.0 V		Unit
			Min	Max	Min	Max	Min	Max	
6	Clock High to FC, Address Valid	$t_{CHFCADV}$	0	45	0	45	0	30	ns
7	Clock High to Address, Data Bus High Impedance (Maximum)	t_{CHADZ}	—	50	—	50	—	33	ns
8	Clock High to Address, FC Invalid (Minimum)	t_{CHAFI}	0	—	0	—	0	—	ns
9	Clock High to \overline{AS} , \overline{DS} Asserted (see Note 1)	t_{CHSL}	3	30	3	30	3	20	ns
11	Address, FC Valid to \overline{AS} , \overline{DS} Asserted (Read) \overline{AS} Asserted Write (see Note 2)	t_{AFCVSL}	15	—	15	—	10	—	ns
12	Clock Low to \overline{AS} , \overline{DS} Negated (see Note 1)	t_{CLSH}	—	30	—	30	—	20	ns
13	\overline{AS} , \overline{DS} Negated to Address, FC Invalid (see Note 2)	t_{SHAFI}	15	—	15	—	10	—	ns
14	\overline{AS} (and \overline{DS} Read) Width Asserted (see Note 2)	t_{SL}	120	—	120	—	80	—	ns
14A	\overline{DS} Width Asserted, Write (see Note 2)	t_{DSL}	60	—	60	—	40	—	ns
15	\overline{AS} , \overline{DS} Width Negated (see Note 2)	t_{SH}	60	—	60	—	40	—	ns
16	Clock High to Control Bus High Impedance	t_{CHCZ}	—	50	—	50	—	33	ns
17	\overline{AS} , \overline{DS} Negated to R/\overline{W} Invalid (see Note 2)	t_{SHRH}	15	—	15	—	10	—	ns
18	Clock High to R/\overline{W} High (see Note 1)	t_{CHRH}	—	30	—	30	—	20	ns
20	Clock High to R/\overline{W} Low (see Note 1)	t_{CHRL}	—	30	—	30	—	20	ns
20A	\overline{AS} Asserted to R/\overline{W} Low (Write) (see Notes 2 and 6)	t_{ASRV}	—	10	—	10	—	7	ns
21	Address FC Valid to R/\overline{W} Low (Write) (see Note 2)	t_{AFCVRL}	15	—	15	—	10	—	ns
22	R/\overline{W} Low to \overline{DS} Asserted (Write) (see Note 2)	t_{RLSL}	30	—	30	—	20	—	ns
23	Clock Low to Data-Out Valid	t_{CLDO}	—	30	—	30	—	20	ns
25	\overline{AS} , \overline{DS} , Negated to Data-Out Invalid (Write) (see Note 2)	t_{SHDOI}	15	—	15	—	10	—	ns
26	Data-Out Valid to \overline{DS} Asserted (Write) (see Note 2)	t_{DOSL}	15	—	15	—	10	—	ns
27	Data-In Valid to Clock Low (Setup Time on Read) (see Note 5)	t_{DICL}	7	—	7	—	5	—	ns
28	\overline{AS} , \overline{DS} Negated to \overline{DTACK} Negated (Asynchronous Hold) (see Note 2)	t_{SHDAH}	0	110	0	110	0	75	ns
29	\overline{AS} , \overline{DS} Negated to Data-In Invalid (Hold Time on Read)	t_{SHDII}	0	—	0	—	—	—	ns
31	\overline{DTACK} Asserted to Data-In Valid (Setup Time) (see Notes 2 and 5)	t_{DALDI}	—	50	—	50	—	33	ns
32	\overline{HALT} and \overline{RESET} Input Transition Time	t_{RHr} , t_{RHf}	—	150	—	150	—	150	ns
44	\overline{AS} , \overline{DS} Negated to \overline{AVEC} Negated	t_{SHVPH}	0	50	0	50	0	33	ns
47	Asynchronous Input Setup Time (see Note 5)	t_{ASI}	10	—	10	—	7	—	ns
53	Data-Out Hold from Clock High	t_{CHDOI}	0	—	0	—	0	—	ns
55	R/\overline{W} Asserted to Data Bus Impedance Change	t_{RLDBD}	0	—	0	—	0	—	ns

56	HALT/RESET Pulse Width (see Note 4)	t _{HRPW}	10	—	10	—	10	—	clks
61	Clock High to BCLR High Impedance (See Note 10)	t _{CHBCH}	—	30	—	30	—	20	ns

NOTES:

- For loading capacitance of less than or equal to 50 pF, subtract 4 ns from the value given in the maximum columns.
- Actual value depends on clock period since signals are driven/latched on different CLKO edges. To calculate the actual spec for other clock frequencies, the user may derive the formula for each specification. First, derive the margin factor as:
 $M = N(P/2) - S_a$
 where N is the number of one-half CLKO periods between the two events as derived from the timing diagram, P is the rated clock period of the device for which the specs were derived (e.g., 60 ns with a 16.67-MHz device or 50 ns with a 20 MHz device), and S_a is the actual spec in the data sheet. Thus, for spec 14 at 16.67 MHz:
 $M = 5(60 \text{ ns}/2) - 120 \text{ ns} = 30 \text{ ns}$.
 Once the margin (M) is calculated for a given spec, a new value of that spec (S_n) at another clock frequency with period (P_a) is calculated as:
 $S_n = N(P_a/2) - M$
 Thus for spec 14 at 12.5 MHz:
 $S_n = 5(80 \text{ ns}/2) - 30 \text{ ns} = 170 \text{ ns}$.
 These two formulas assume a 50% duty cycle. Otherwise, if N is odd, the previous values N(P/2) and N(P_a/2) must be reduced by X, where X is the difference between the nominal pulse width and the minimum pulse width of the EXTAL input clock for that duty cycle.
- For power-up, the MC68302 must be held in the reset state for 100 ms (or 2.3sec if MF=401) to allow stabilization of on-chip circuit. After the system is powered up #56 refers to the minimum pulse width required to reset the processor.
- If the asynchronous input setup (#47) requirement is satisfied for \overline{DTACK} , the \overline{DTACK} asserted to data setup time (#31) requirement can be ignored. The data must only satisfy the data-in to clock low setup time (#27) for the following clock cycle.
- When \overline{AS} and R/\overline{W} are equally loaded ($\pm 20\%$), subtract 5 ns from the values given in these columns.

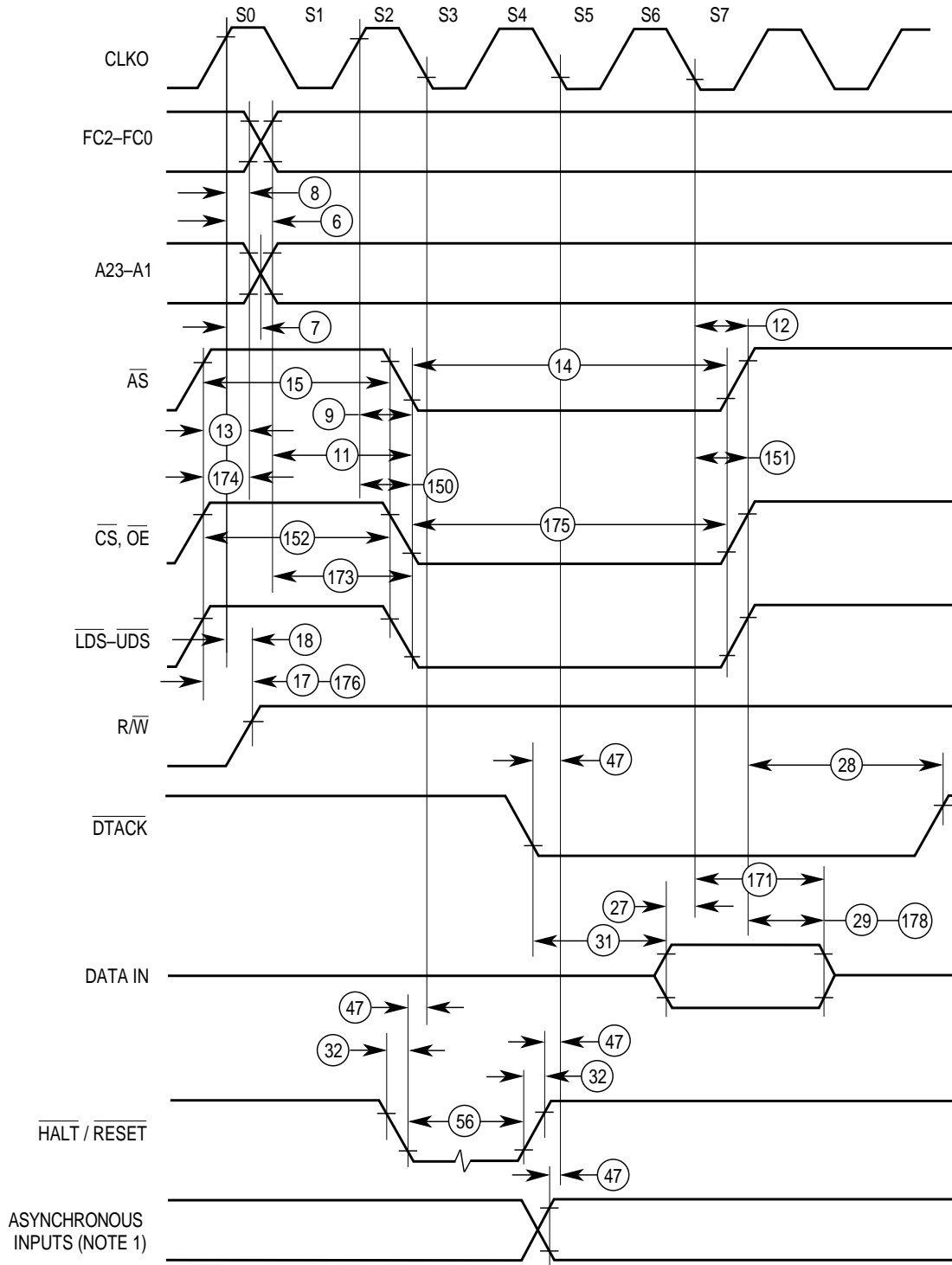

NOTES:

1. Setup time for the asynchronous inputs $\overline{IPL2}$ – $\overline{IPL0}$ guarantees their recognition at the next falling edge of the clock.
2. \overline{BR} need fall at this time only to insure being recognized at the end of the bus cycle.
3. Timing measurements are referenced to and from a low voltage of 0.8 volt and a high voltage of 2.0 volts, unless otherwise noted. The voltage swing through this range should start outside and pass through the range such that the rise or fall is linear between 0.8 volts and 2.0 volts.

Figure 6-2. Read Cycle Timing Diagram

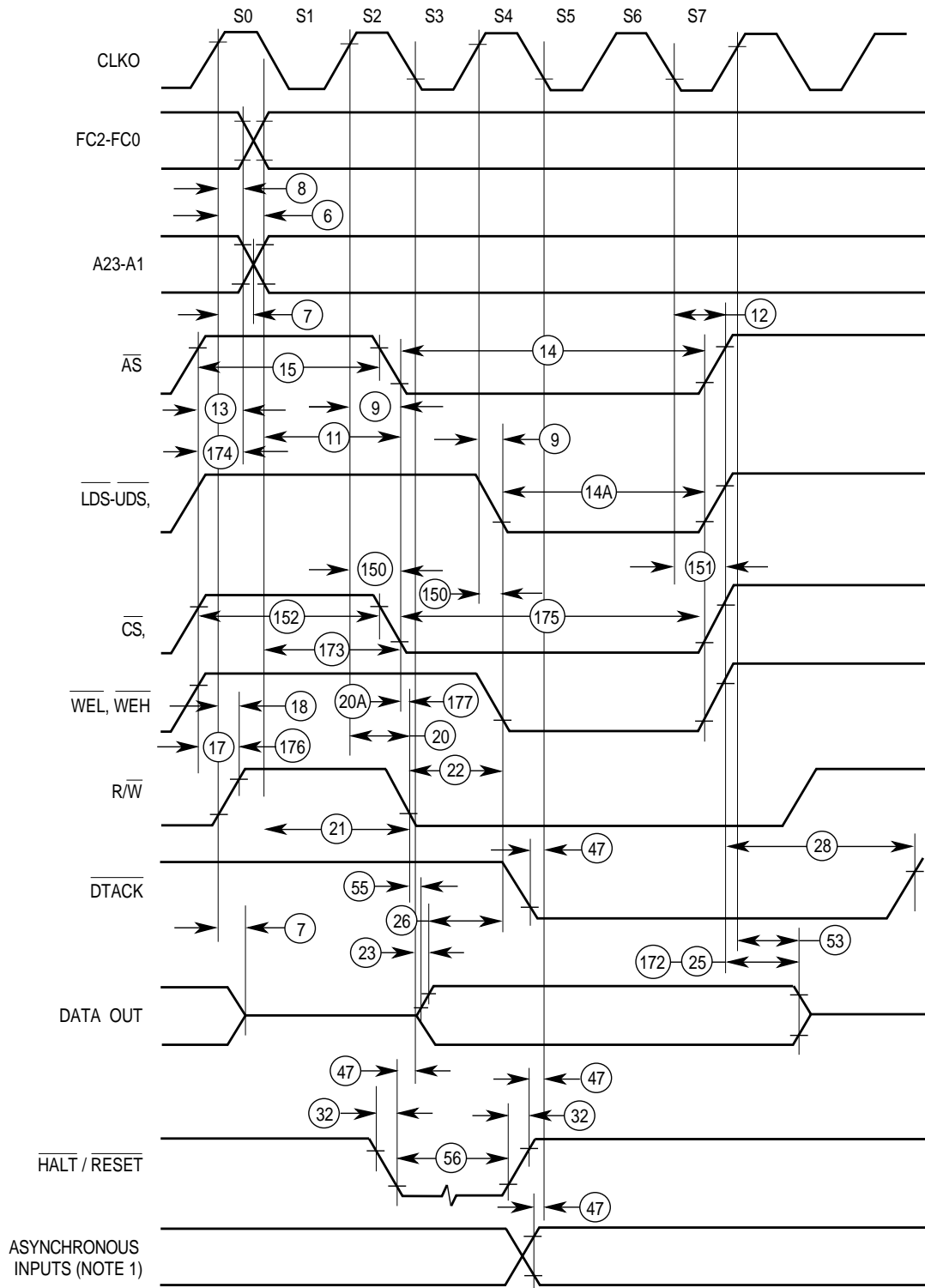

NOTES:

1. Timing measurements are referenced to and from a low voltage of 0.8 volt and a high voltage of 2.0 volts, unless otherwise noted. The voltage swing through this range should start outside and pass through the range such that the rise or fall is linear between 0.8 volt and 2.0 volts.
2. Because of loading variations, R/W may be valid after AS even though both are initiated by the rising edge of S2 (specification #20A)
3. Each wait state is a full clock cycle inserted between S4 and S5.

Figure 6-3. Write Cycle Timing Diagram

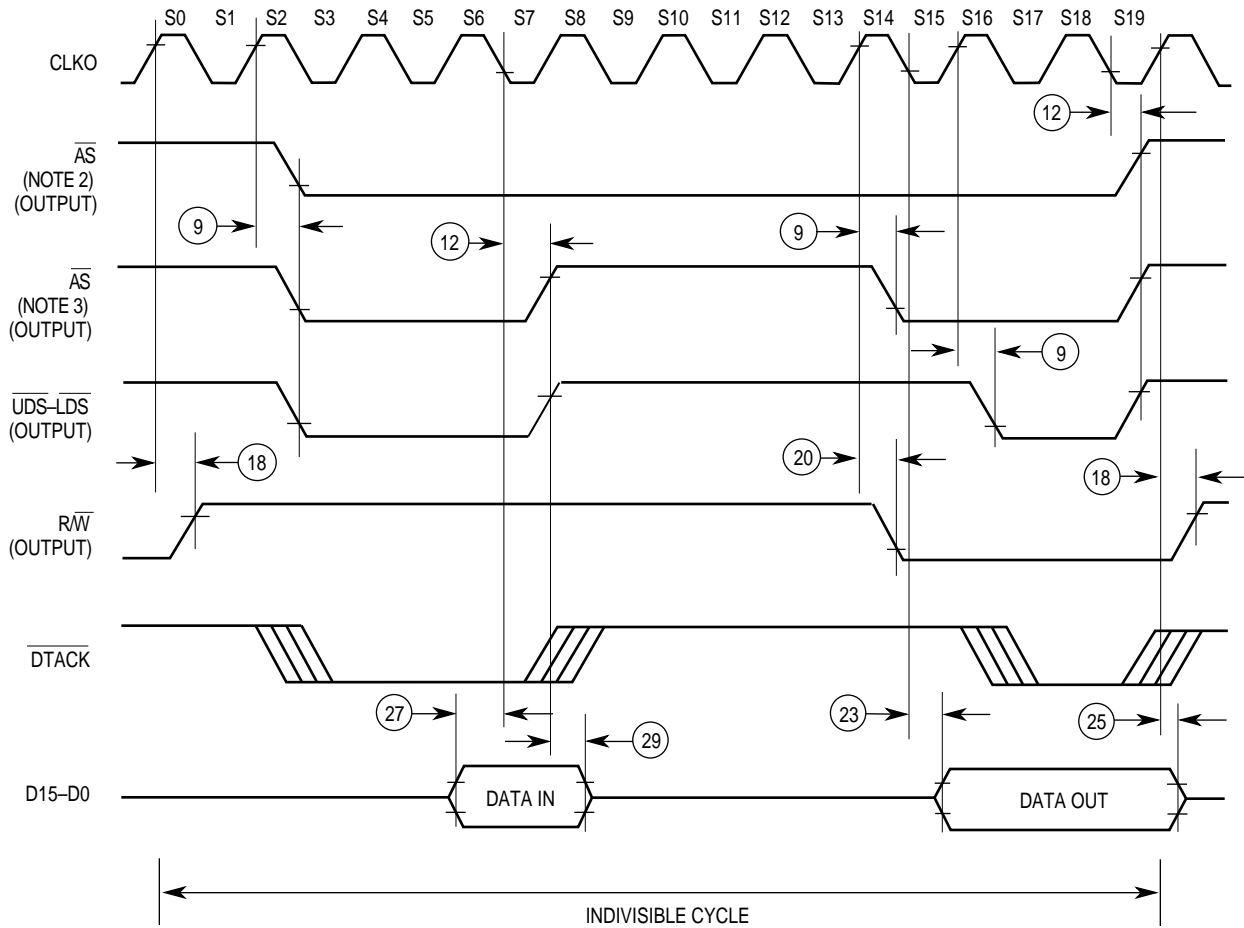

Figure 6-4. Read-Modify-Write Cycle Timing Diagram

6.9 AC ELECTRICAL SPECIFICATIONS—DMA (see Figure 6-5 and Figure 6-6)

Num.	Characteristic	Symbol	16.67 MHz		20 MHz		25 MHz		Unit
			Min	Max	Min	Max	Min	Max	
83	Clock High to \overline{BR} Low (see Notes 3 and 4)	t_{CHBRL}	—	30	—	25	—	20	ns
84	Clock High to \overline{BR} High Impedance (see Notes 3 and 4)	t_{CHBRZ}	—	30	—	25	—	20	ns
85	\overline{BGACK} Low to \overline{BR} High Impedance (see Notes 3 and 4)	t_{BKLBRZ}	30	—	25	—	20	—	ns
86	Clock High to \overline{BGACK} Low	t_{CHBKL}	—	30	—	25	—	20	ns
87	\overline{AS} and \overline{BGACK} High (the Latest One) to \overline{BGACK} Low (when \overline{BG} Is Asserted)	t_{ABHBKL}	1.5	2.5 +30	1.5	2.5 +25	1.5	2.5 +20	clks ns
88	\overline{BG} Low to \overline{BGACK} Low (No Other Bus Master) (see Notes 3 and 4)	t_{BGLBKL}	1.5	2.5 +30	1.5	2.5 +25	1.5	2.5 +20	clks ns
89	\overline{BR} High Impedance to \overline{BG} High (see Notes 3 and 4)	t_{BRHBGH}	0	—	0	—	0	—	ns
90	Clock on which \overline{BGACK} Low to Clock on which \overline{AS} Low	$t_{CLBKLAL}$	2	2	2	2	2	2	clks
91	Clock High to \overline{BGACK} High	t_{CHBKH}	—	30	—	25	—	20	ns
92	Clock Low to \overline{BGACK} High Impedance	t_{CLBKZ}	—	15	—	15	—	10	ns

NOTES:

- \overline{BR} will not be asserted while \overline{AS} , \overline{HALT} , or \overline{BERR} is asserted.
- Specifications are for DISABLE CPU mode only.
- DMA and SDMA read and write cycle timing is the same as that for the M68000 core.

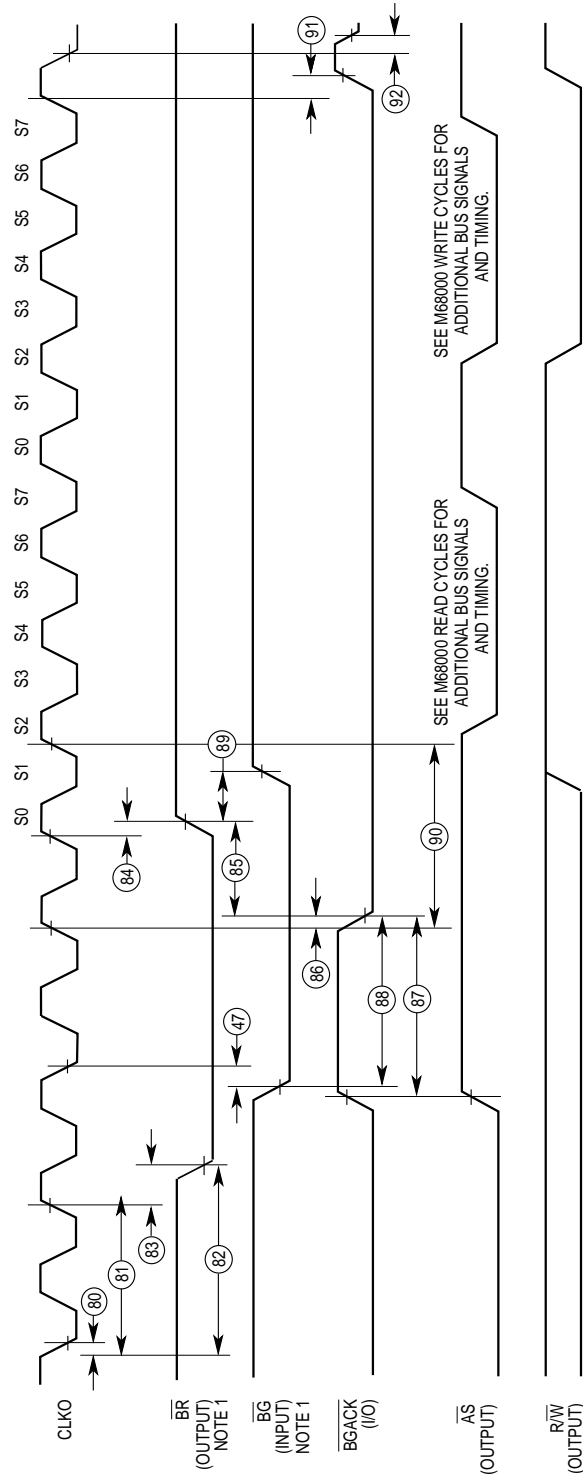

NOTES:
 1. BR and \overline{BG} shown above are only active in disable CPU mode; otherwise, they do not apply to the diagram.

Figure 6-5. DMA Timing Diagram (IDMA)

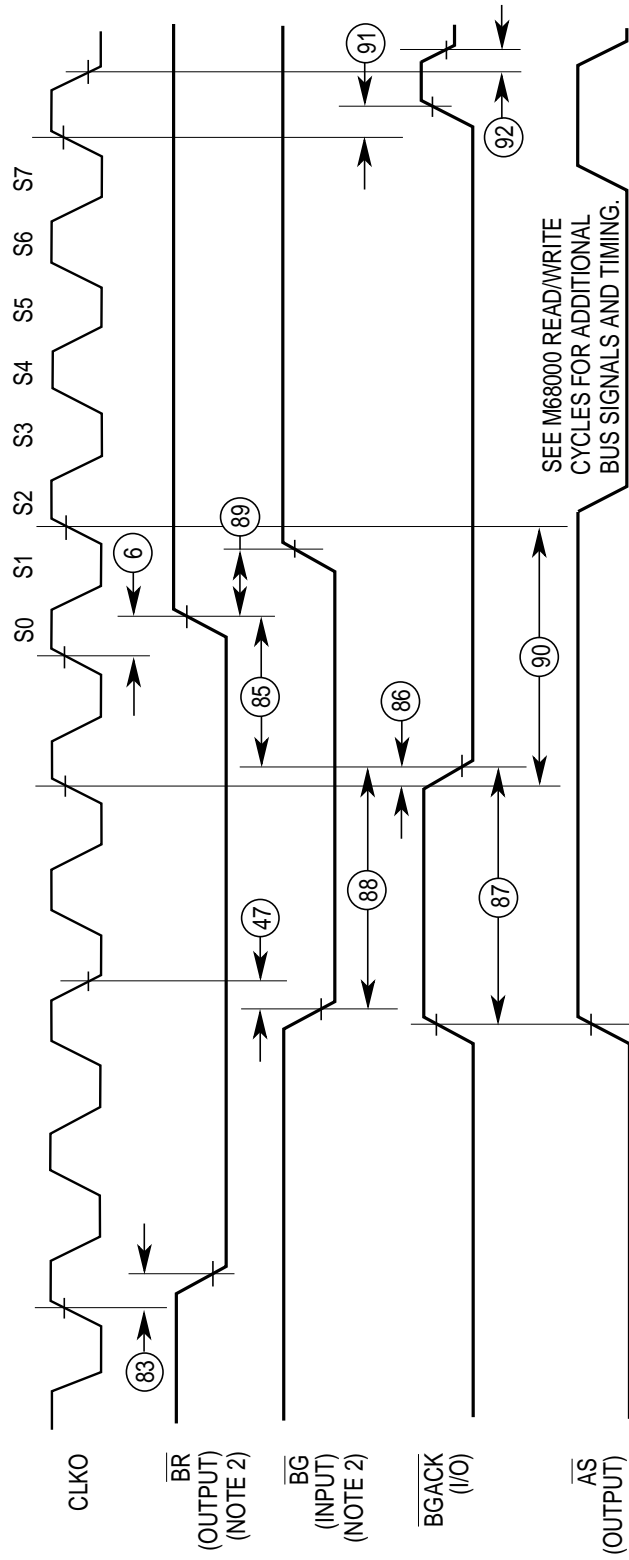

NOTES:
 1. DRAM refresh controller timing is identical to SDMA timing.
 2. BR and BG shown above are only active in disable CPU mode; otherwise they do not apply to the diagram.

Figure 6-6. DMA Timing Diagram (SDMA)

6.10 AC ELECTRICAL SPECIFICATIONS—EXTERNAL MASTER INTERNAL ASYNCHRONOUS READ/WRITE CYCLES

(see Figure 6-7 and Figure 6-8)

Num.	Characteristic	Symbol	16.67 MHz		20 MHz		25 MHz		Unit
			Min	Max	Min	Max	Min	Max	
100	R/\overline{W} Valid to \overline{DS} Low	t_{RWVDSL}	0	—	0	—	0	—	ns
101	\overline{DS} Low to Data-In Valid	$t_{DSL DIV}$	—	30	—	25	—	20	ns
102	\overline{DTACK} Low to Data-In Hold Time	t_{DKLDH}	0	—	0	—	0	—	ns
103	\overline{AS} Valid to \overline{DS} Low	t_{ASVDSL}	0	—	0	—	0	—	ns
104	\overline{DTACK} Low to \overline{AS} , \overline{DS} High	t_{DKLDSH}	0	—	0	—	0	—	ns
105	\overline{DS} High to \overline{DTACK} High	t_{DSHDKH}	—	45	—	40	—	30	ns
106	\overline{DS} Inactive to \overline{AS} Inactive	t_{DSIASI}	0	—	0	—	0	—	ns
107	\overline{DS} High to R/\overline{W} High	t_{DSHRWH}	0	—	0	—	0	—	ns
108	\overline{DS} High to Data High Impedance	t_{DSDHZ}	—	45	—	40	—	30	ns
108A	\overline{DS} High to Data-Out Hold Time (see Note)	t_{DSDH}	0	—	0	—	0	—	ns
109A	Data Out Valid to \overline{DTACK} Low	t_{DOVDKL}	15	—	15	—	10	—	ns

NOTE: If \overline{AS} is negated before \overline{DS} , the data bus could be three-stated (spec 126) before \overline{DS} is negated.

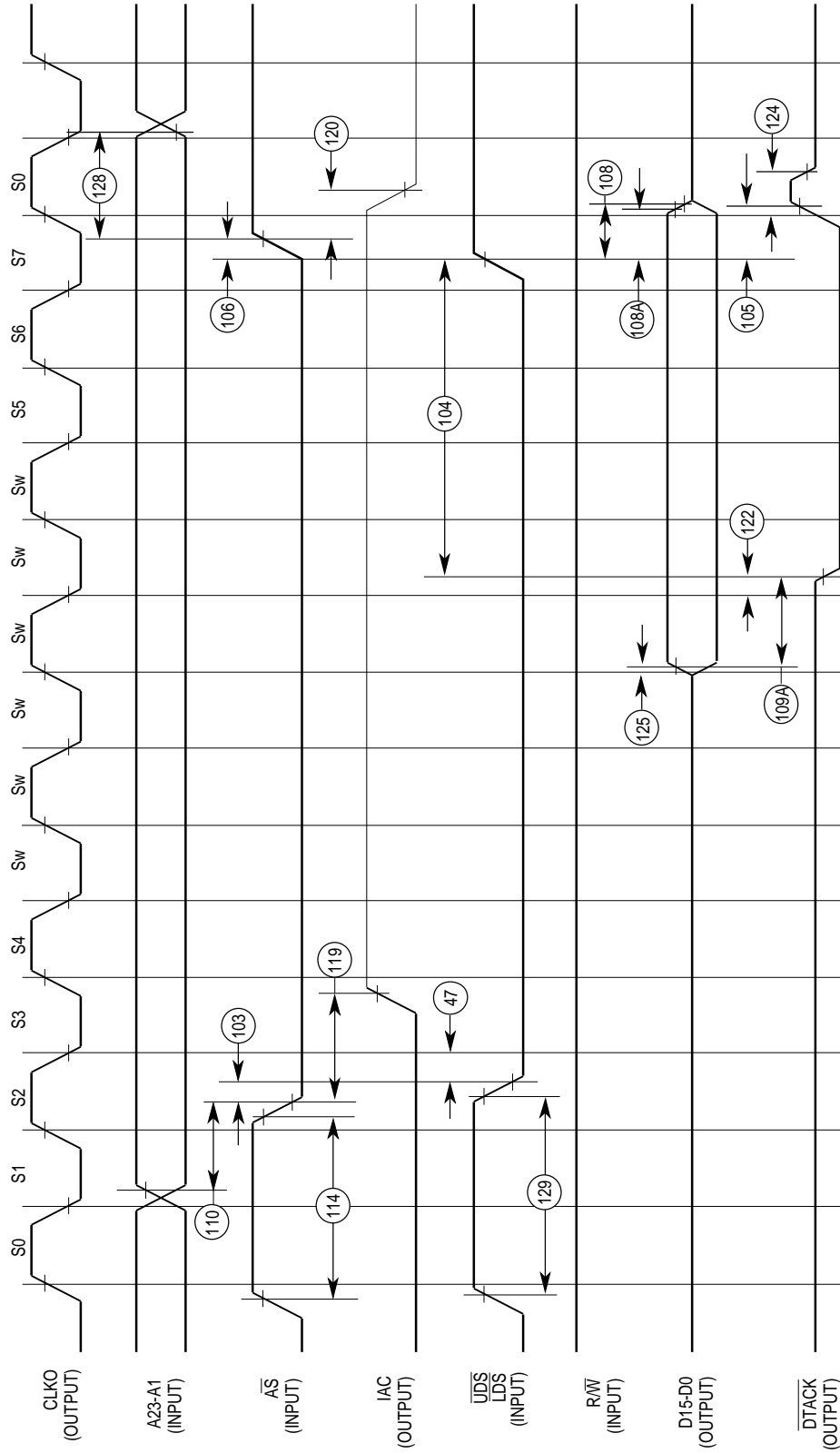

Figure 6-7. External Master Internal Asynchronous Read Cycle Timing Diagram

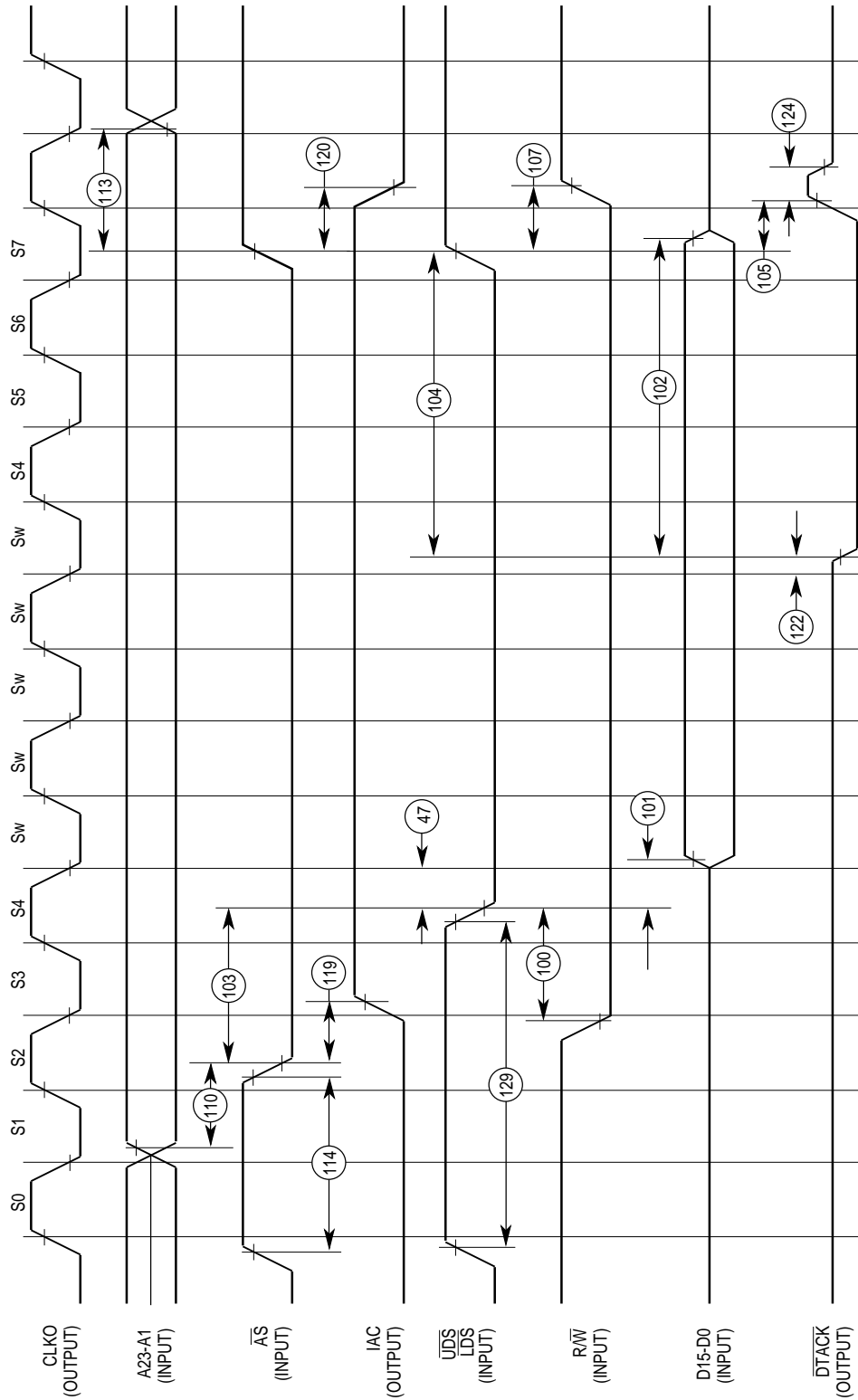

Figure 6-8. External Master Internal Asynchronous Write Cycle Timing Diagram

6.11 AC ELECTRICAL SPECIFICATIONS—EXTERNAL MASTER INTERNAL SYNCHRONOUS READ/WRITE CYCLES

(see Figure 6-9, Figure 6-10, and Figure 6-11)

Num.	Characteristic	Symbol	16.67 MHz		20 MHz		25 MHz		Unit
			Min	Max	Min	Max	Min	Max	
110	Address Valid to \overline{AS} Low	t_{AVASL}	15	—	12	—	10	—	ns
111	\overline{AS} Low to Clock High	t_{ASLCH}	30	—	25	—	20	—	ns
112	Clock Low to \overline{AS} High	t_{CLASH}	—	45	—	40	—	30	ns
113	\overline{AS} High to Address Hold Time on Write	t_{ASHAH}	0	—	0	—	0	—	ns
114	\overline{AS} Inactive Time	t_{ASH}	1	—	1	—	1	—	clk
115	$\overline{UDS/LDS}$ Low to Clock High (see Note 2)	t_{SLCH}	40	—	33	—	27	—	ns
116	Clock Low to $\overline{UDS/LDS}$ High	t_{CLSH}	—	45	—	40	—	30	ns
117	R/\overline{W} Valid to Clock High (see Note 2)	t_{RWVCH}	30	—	25	—	20	—	ns
118	Clock High to R/\overline{W} High	t_{CHRWH}	—	45	—	40	—	30	ns
119	\overline{AS} Low to IAC High	t_{ASLIAH}	—	40	—	35	—	27	ns
120	\overline{AS} High to IAC Low	t_{ASHIAL}	—	40	—	35	—	27	ns
121	\overline{AS} Low to \overline{DTACK} Low (0 Wait State)	t_{ASLDTL}	—	45	—	40	—	30	ns
122	Clock Low to \overline{DTACK} Low (1 Wait State)	t_{CLDTL}	—	30	—	25	—	20	ns
123	\overline{AS} High to \overline{DTACK} High	t_{ASHDTH}	—	45	—	40	—	30	ns
124	\overline{DTACK} High to \overline{DTACK} High Impedance	t_{DTHDTZ}	—	15	—	15	—	10	ns
125	Clock High to Data-Out Valid	t_{CHDOV}	—	30	—	25	—	20	ns
126	\overline{AS} High to Data High Impedance	t_{ASHDZ}	—	45	—	40	—	30	ns
127	\overline{AS} High to Data-Out Hold Time	t_{ASHDOI}	0	—	0	—	0	—	ns
128	\overline{AS} High to Address Hold Time on Read	t_{ASHAI}	0	—	0	—	0	—	ns
129	$\overline{UDS/LDS}$ Inactive Time	t_{SH}	1	—	1	—	1	—	clk
130	Data-In Valid to Clock Low	t_{CLDIV}	30	—	25	—	20	—	ns
131	Clock Low to Data-In Hold Time	t_{CLDIH}	15	—	12	—	10	—	ns

NOTES:

1. Synchronous specifications above are valid only when $SAM = 1$ in the SCR.
2. It is required that this signal not be asserted prior to the previous rising CLKO edge (i.e., in the previous clock cycle). It must be recognized by the IMP no sooner than the rising CLKO edge shown in the diagram.

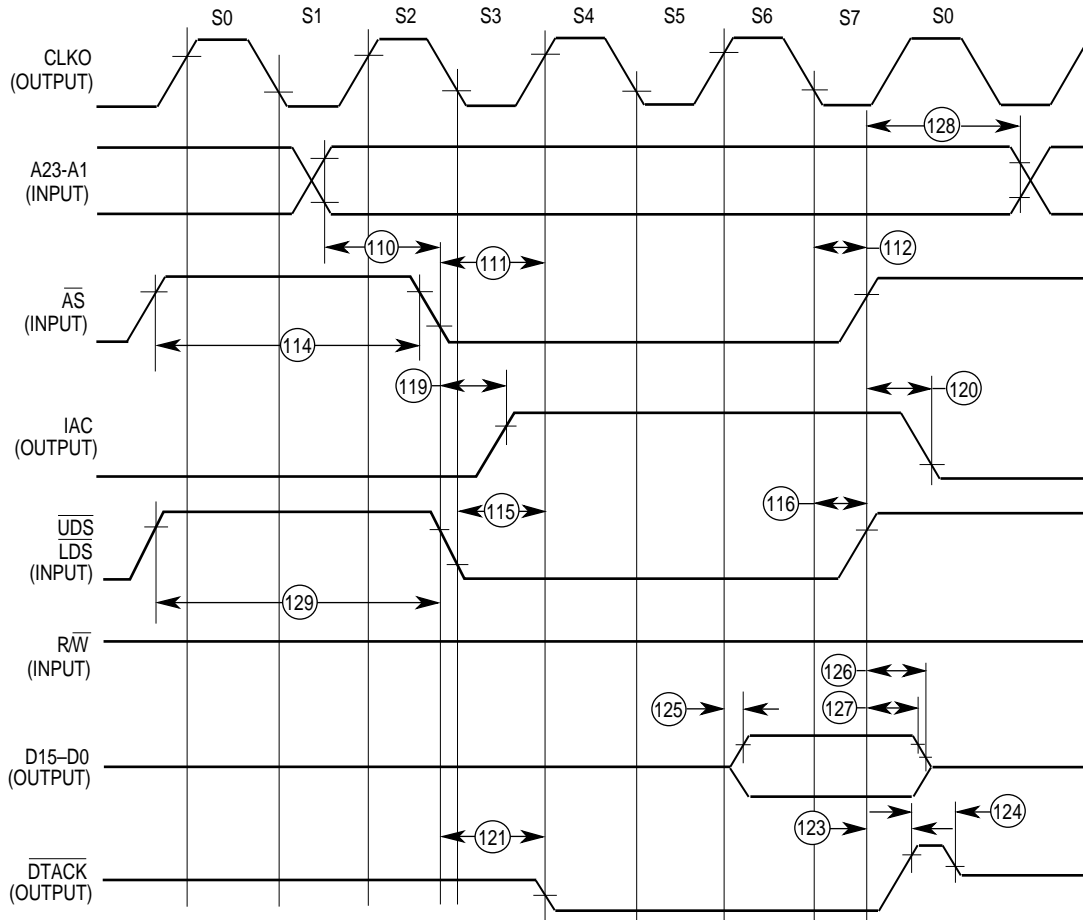

Figure 6-9. External Master Internal Synchronous Read Cycle Timing Diagram

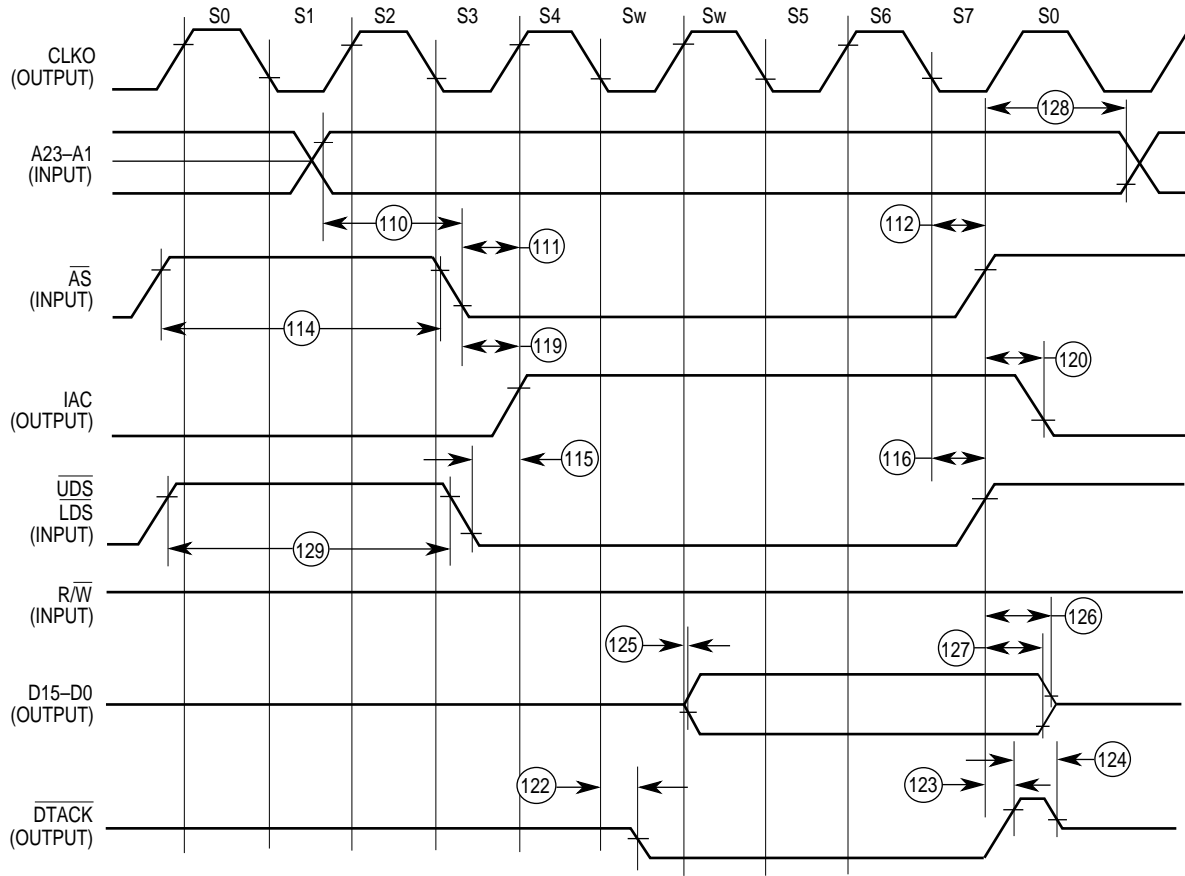

Figure 6-10. External Master Internal Synchronous Read Cycle Timing Diagram (One Wait State)

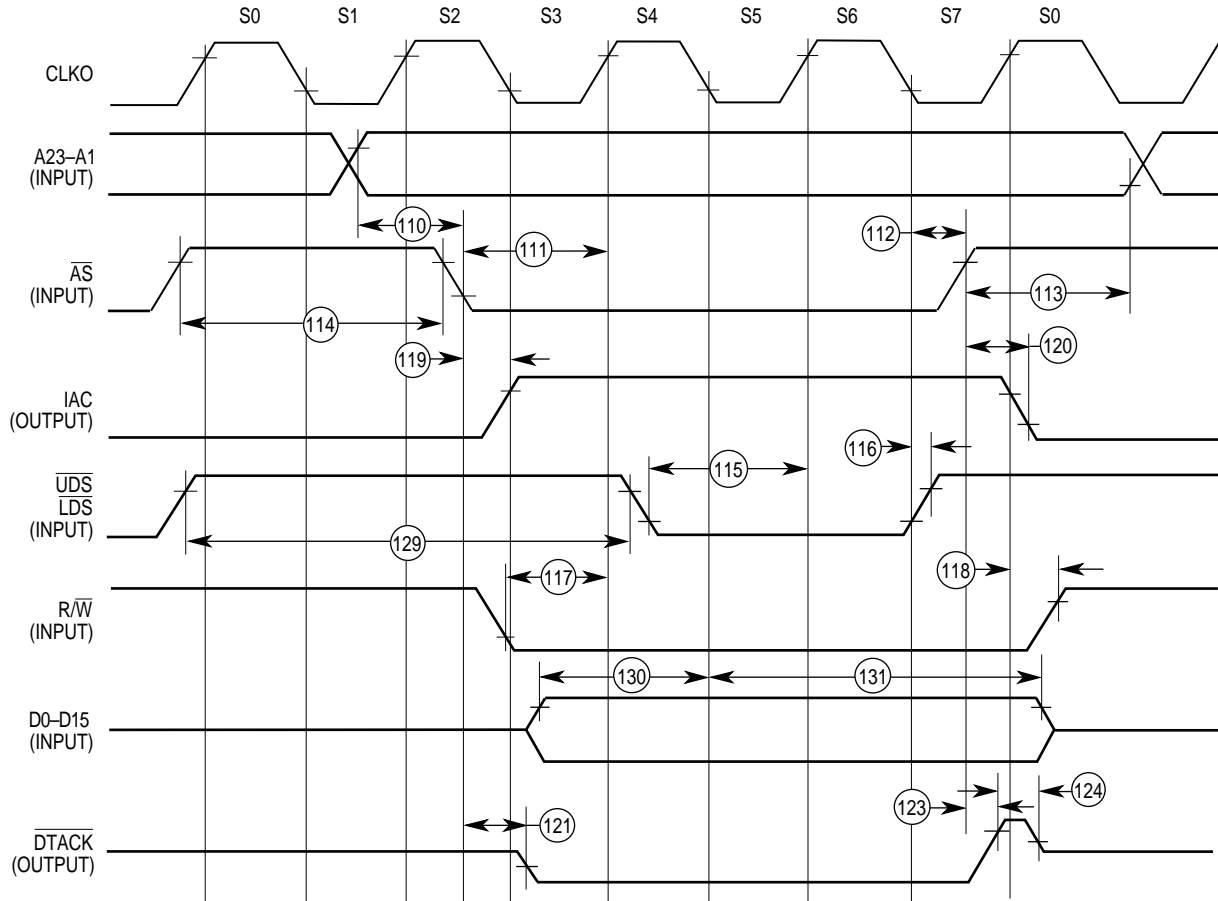

Figure 6-11. External Master Internal Synchronous Write Cycle Timing Diagram

6.12 AC ELECTRICAL SPECIFICATIONS—INTERNAL MASTER INTERNAL READ/WRITE CYCLES (see Figure 6-12)

Num.	Characteristic	Symbol	16.67 MHz		20 MHz		25 MHz		Unit
			Min	Max	Min	Max	Min	Max	
140	Clock High to IAC High	t_{CHIAH}	—	40	—	35	—	27	ns
141	Clock Low to IAC Low	t_{CLIAL}	—	40	—	35	—	27	ns
142	Clock High to \overline{DTACK} Low	t_{CHDTL}	—	45	—	40	—	30	ns
143	Clock Low to \overline{DTACK} High	t_{CLDTH}	—	40	—	35	—	27	ns
144	Clock High to Data-Out Valid	t_{CHDOV}	—	30	—	25	—	20	ns
145	\overline{AS} High to Data-Out Hold Time	t_{ASHDOH}	0	—	0	—	0	—	ns

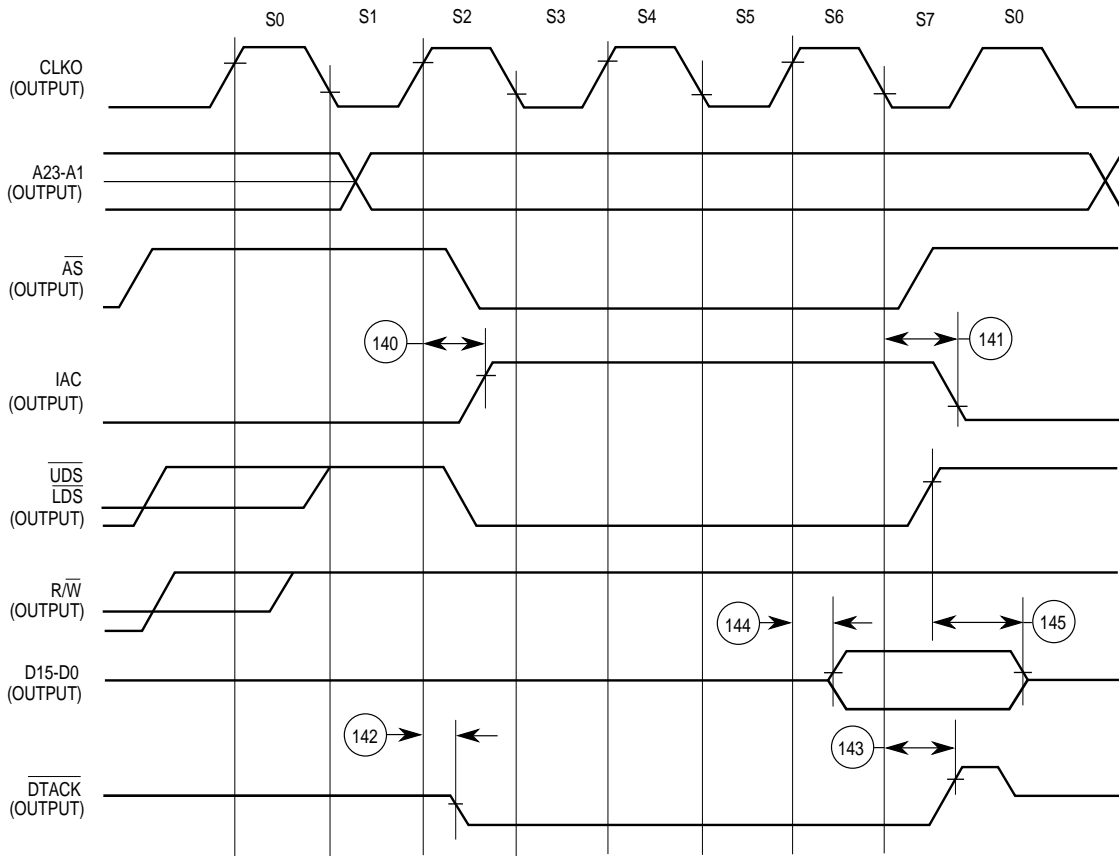

Figure 6-12. Internal Master Internal Read Cycle Timing Diagram

6.13 AC ELECTRICAL SPECIFICATIONS—CHIP-SELECT TIMING INTERNAL MASTER (see Figure 6-13)

Num.	Characteristic	Symbol	16.67 MHz		20 MHz		25 MHz		Unit
			Min	Max	Min	Max	Min	Max	
150	Clock High to \overline{CS} , \overline{IACK} , \overline{OE} , \overline{WEL} , \overline{WEH} Low (see Note 2)	$t_{CHCSIAKL}$	0	40	0	35	0	27	ns
151	Clock Low to \overline{CS} , \overline{IACK} , \overline{OE} , \overline{WEL} , \overline{WEH} High (see Note 2)	$t_{CLCSIAKH}$	0	40	0	35	0	27	ns
152	\overline{CS} Width Negated	t_{CSH}	60	—	50	—	40	—	ns
153	Clock High to \overline{DTACK} Low (0 Wait State)	t_{CHDTKL}	—	45	—	40	—	30	ns
154	Clock Low to \overline{DTACK} Low (1–6 Wait States)	t_{CLDTKL}	—	30	—	25	—	20	ns
155	Clock Low to \overline{DTACK} High	t_{CLDTKH}	—	40	—	35	—	27	ns
158	\overline{DTACK} High to \overline{DTACK} High Impedance	$t_{DTKHDTKZ}$	—	15	—	15	—	27	ns
171	Input Data Hold Time from S6 Low	t_{IDHCL}	5	—	5	—	—	27	ns
172	\overline{CS} Negated to Data-Out Invalid (Write)	t_{CSNDOI}	10	—	10	—	—	10	ns
173	Address, FC Valid to \overline{CS} Asserted	t_{AFVCSA}	15	—	15	—	5	—	ns
174	\overline{CS} Negated to Address, FC Invalid	t_{CSNAFI}	15	—	15	—	7	—	ns
175	\overline{CS} Low Time (0 Wait States)	t_{CSLT}	120	—	100	—	15	—	ns
176	\overline{CS} Negated to R/\overline{W} Invalid	t_{CSNRWI}	10	—	10	—	12	—	ns
177	\overline{CS} Asserted to R/\overline{W} Low (Write)	t_{CSARWL}	—	10	—	10	80	—	ns
178	\overline{CS} Negated to Data-In Invalid (Hold Time on Read)	t_{CSNDII}	0	—	0	—	7	—	ns

NOTE:

1. This specification is valid only when the ADCE or WPVE bits in the SCR are set.
2. For loading capacitance less than or equal to 50 pF, subtract 4 ns from the maximum value given.
3. Since \overline{AS} and \overline{CS} are asserted/negated on the same CLK0 edges, no \overline{AS} to \overline{CS} relative timings can be specified. However, \overline{CS} timings are given relative to a number of other signals, in the same manner as \overline{AS} . See Figure 6-2 and Figure 6-3 for diagrams.

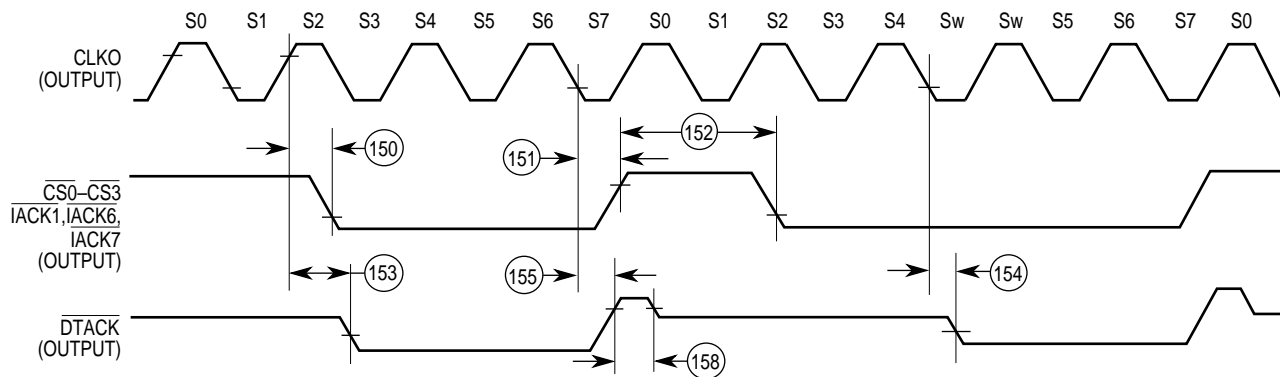

Figure 6-13. Internal Master Chip-Select Timing Diagram

6.14 AC ELECTRICAL SPECIFICATIONS—CHIP-SELECT TIMING EXTERNAL MASTER

(see Figure 6-14)

Num.	Characteristic	Symbol	16.67 MHz		20 MHz		25 MHz		Unit
			Min	Max	Min	Max	Min	Max	
154	Clock Low to \overline{DTACK} Low (1-6 Wait States)	t_{CLDTKL}	—	30	—	25	—	20	ns
160	\overline{AS} Low to \overline{CS} Low	t_{ASLCSL}	—	30	—	25	—	20	ns
161	\overline{AS} High to \overline{CS} High	t_{ASHCSH}	—	30	—	25	—	20	ns
162	Address Valid to \overline{AS} Low	t_{AVASL}	15	—	12	—	10	—	ns
164	\overline{AS} Negated to Address Hold Time	t_{ASHAI}	0	—	0	—	0	—	ns
165	\overline{AS} Low to \overline{DTACK} Low (0 Wait State)	$t_{ASLDTKL}$	—	45	—	40	—	30	ns
167	\overline{AS} High to \overline{DTACK} High	$t_{ASHDTKH}$	—	30	—	25	—	20	ns

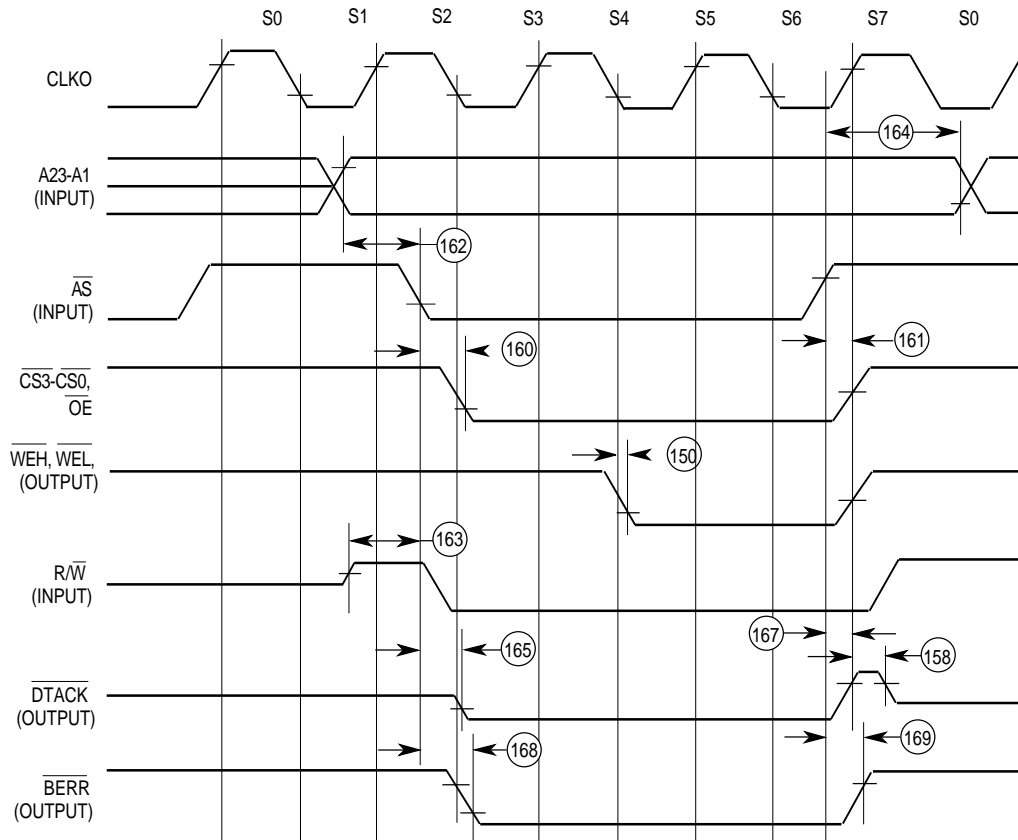

Figure 6-14. External Master Chip-Select Timing Diagram

6.15 AC ELECTRICAL SPECIFICATIONS—PARALLEL I/O

(see Figure 6-15)

Num.	Characteristic	Symbol	16.67 MHz		20 MHz		25 MHz		Unit
			Min	Max	Min	Max	Min	Max	
180	Input Data Setup Time (to Clock Low)	t_{DSU}	20	—	20	—	14	—	ns
181	Input Data Hold Time (from Clock Low)	t_{DH}	10	—	10	—	19	—	ns
182	Clock High to Data-out Valid (CPU Writes Data, Control, or Direction)	t_{CHDOV}	—	35	—	30	—	24	ns

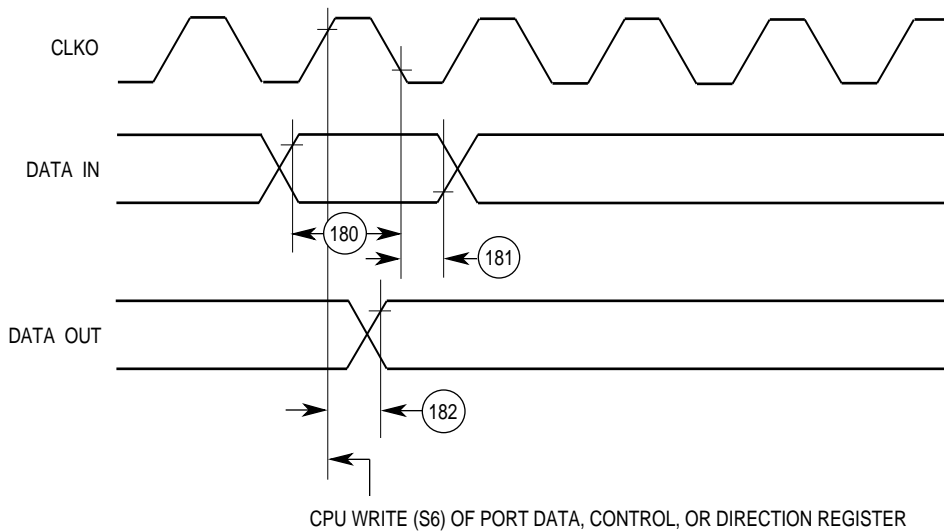

Figure 6-15. Parallel I/O Data-In/Data-Out Timing Diagram

6.16 AC ELECTRICAL SPECIFICATIONS—INTERRUPTS

(see Figure 6-16)

Num.	Characteristic	Symbol	16.67 MHz		20 MHz		25 MHz		Unit
			Min	Max	Min	Max	Min	Max	
190	Interrupt Pulse Width Low \overline{IRQ} (Edge Triggered Mode)	t_{PW}	50	—	42	—	34	—	ns
191	Minimum Time Between Active Edges	t_{AEMT}	3	—	3	—	3	—	clk

NOTE: Setup time for the asynchronous inputs $\overline{IPL2-IPL0}$ and \overline{AVEC} guarantees their recognition at the next falling edge of the clock.

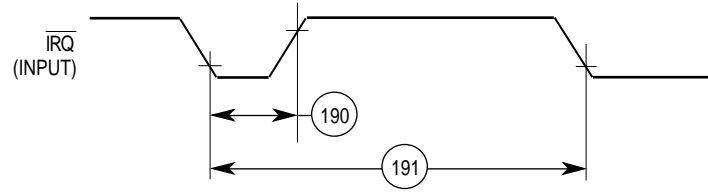

Figure 6-16. Interrupts Timing Diagram

6.17 AC ELECTRICAL SPECIFICATIONS—TIMERS

NOTE: The FRZ pin is not implemented on the LC302.

(see Figure 6-17)

Num.	Characteristic	Symbol	16.67 MHz		20 MHz		25 MHz		Unit
			Min	Max	Min	Max	Min	Max	
200	Timer Input Capture Pulse Width	t_{TPW}	50	—	42	—	34	—	ns
201	TIN Clock Low Pulse Width	t_{TICLT}	50	—	42	—	34	—	ns
202	TIN Clock High Pulse Width and Input Capture High Pulse Width	t_{TICHT}	2	—	2	—	2	—	clk
203	TIN Clock Cycle Time	t_{cyc}	3	—	3	—	3	—	clk
204	Clock High to TOUT Valid	t_{CHTOV}	—	35	—	30	—	24	ns
205	\overline{FRZ} Input Setup Time (to Clock High) (see Note 1)	t_{FRZSU}	20	—	20	—	14	—	ns
206	\overline{FRZ} Input Hold Time (from Clock High)	t_{FRZHT}	10	—	10	—	7	—	ns

NOTES:

1. \overline{FRZ} should be negated during total system reset.
2. The TIN specs above do not apply to the use of TIN1 as a baud rate generator input clock. In such a case, specifications 1–3 may be used.

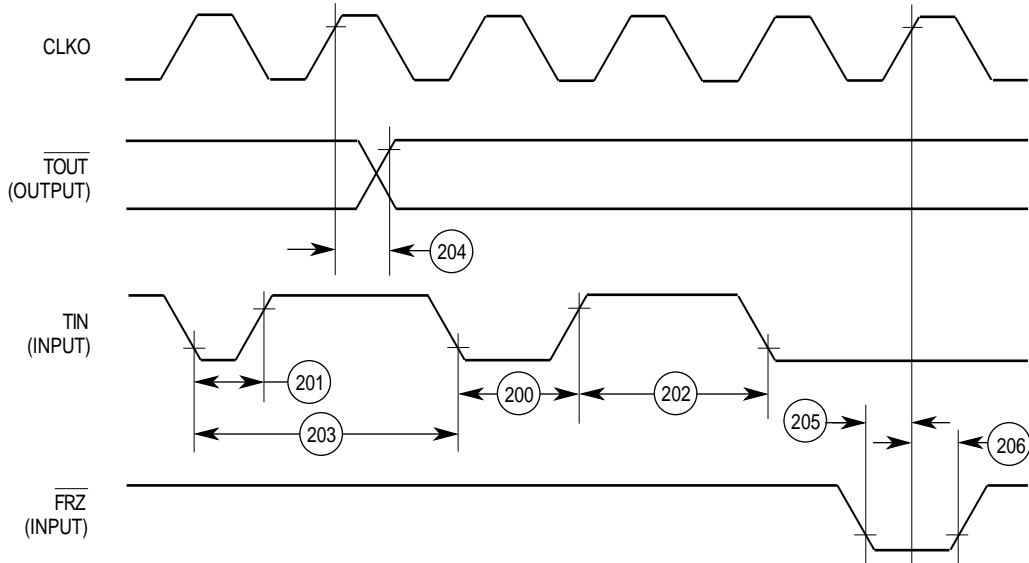

Figure 6-17. Timers Timing Diagram

6.18 AC ELECTRICAL SPECIFICATIONS—SERIAL COMMUNICATIONS PORT (see Figure 6-18).

Num.	Characteristic	16.67 MHz		20 MHz		25 MHz		Unit
		Min	Max	Min	Max	Min	Max	
250	SPCLK Clock Output Period	4	64	4	64	4	64	clks
251	SPCLK Clock Output Rise/Fall Time	0	15	0	10	0	8	ns
252	Delay from SPCLK to Transmit (see Note 1)	0	40	0	30	0	24	ns
253	SCP Receive Setup Time (see Note 1)	40	—	30	—	24	—	ns
254	SCP Receive Hold Time (see Note 1)	10	—	8	—	7	—	ns

NOTES:

1. This also applies when SPCLK is inverted by CI in the SPMODE register.
2. The enable signals for the slaves may be implemented by the parallel I/O pins.

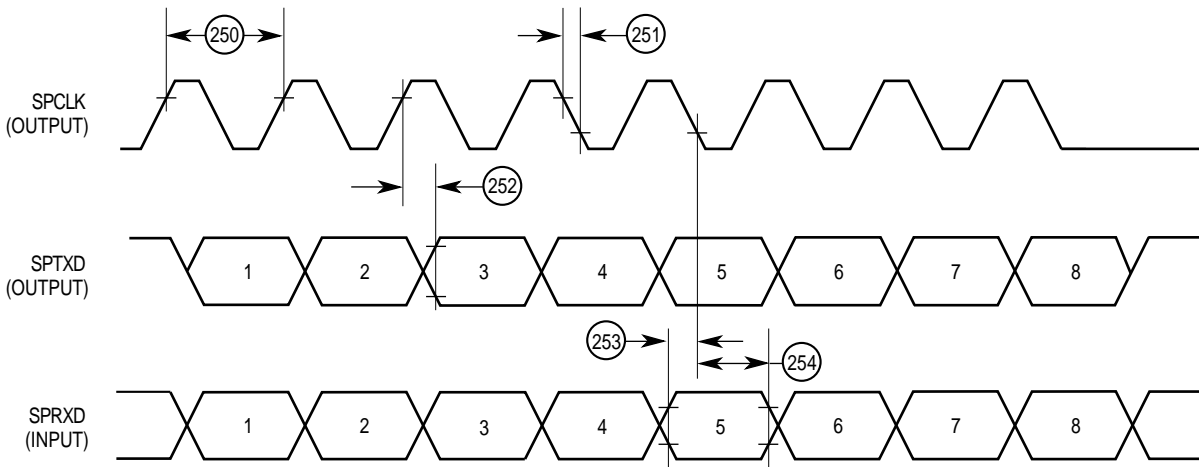

Figure 6-18. Serial Communication Port Timing Diagram

6.19 AC ELECTRICAL SPECIFICATIONS—IDL TIMING (All timing measurements, unless otherwise specified, are referenced to the L1CLK at 50% point of V_{DD}) (see Figure 6-19)

Num.	Characteristic	16.67 MHz		20 MHz		25 MHz		Unit
		Min	Max	Min	Max	Min	Max	
260	L1CLK (IDL Clock) Frequency (see Note 1)	—	6.66	—	8	—	10	MHz
261	L1CLK Width Low	55	—	45	—	37	—	ns
262	L1CLK Width High (see Note 3)	P+10	—	P+10	—	P+10	—	ns
263	L1TXD, L1RQ, SDS1–SDS2 Rising/Falling Time	—	20	—	17	—	14	ns
264	L1SY1 (sync) Setup Time (to L1CLK Falling Edge)	30	—	25	—	20	—	ns
265	L1SY1 (sync) Hold Time (from L1CLK Falling Edge)	50	—	40	—	34	—	ns
266	L1SY1 (sync) Inactive Before 4th L1CLK	0	—	0	—	0	—	ns
267	L1TxD Active Delay (from L1CLK Rising Edge)	0	75	0	65	0	50	ns
268	L1TxD to High Impedance (from L1CLK Rising Edge) (see Note 2)	0	50	0	42	0	34	ns
269	L1RxD Setup Time (to L1CLK Falling Edge)	50	—	42	—	34	—	ns
270	L1RxD Hold Time (from L1CLK Falling Edge)	50	—	42	—	34	—	ns
271	Time Between Successive IDL syncs	20	—	20	—	20	—	L1CLK
272	L1RQ Valid before Falling Edge of L1SY1	1	—	1	—	1	—	L1CLK
273	L1GR Setup Time (to L1SY1 Falling Edge)	50	—	42	—	34	—	ns
274	L1GR Hold Time (from L1SY1 Falling Edge)	50	—	42	—	34	—	ns
275	SDS1–SDS2 Active Delay from L1CLK Rising Edge	10	75	10	65	7	50	ns
276	SDS1–SDS2 Inactive Delay from L1CLK Falling Edge	10	75	10	65	7	50	ns

NOTES:

1. The ratio CLKO/L1CLK must be greater than 2.5/1.
2. High impedance is measured at the 30% and 70% of V_{DD} points, with the line at $V_{DD}/2$ through 10K in parallel with 130 pF.
3. Where $P = 1/CLKO$. Thus, for a 16.67-MHz CLKO rate, $P = 60$ ns.

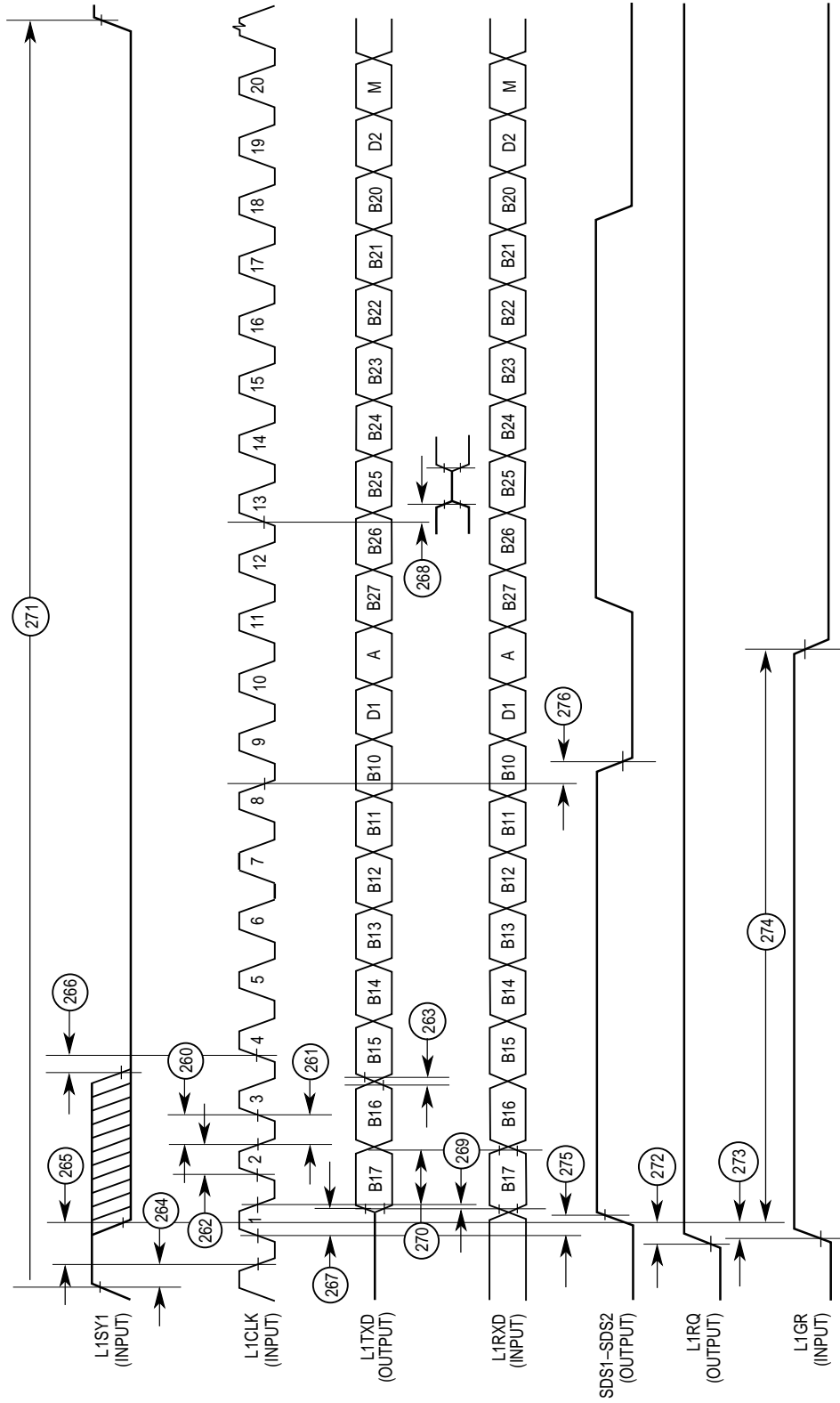

Figure 6-19. IDL Timing Diagram

6.20 AC ELECTRICAL SPECIFICATIONS—GCI TIMING

GCI supports the NORMAL mode and the GCI channel 0 (GCN0) in MUX mode. Normal mode uses 512 kHz clock rate (256K bit rate). MUX mode uses 256 x n - 3088 kbs (clock rate is data rate x 2). The ratio CLKO/L1CLK must be greater than 2.5/1 (see Figure 6-20).

Num.	Characteristic	16.67 MHz		20 MHz		25 MHz		Unit
		Min	Max	Min	Max	Min	Max	
	L1CLK GCI Clock Frequency (Normal Mode) (see Note 1)	—	512	—	512	—	512	kHz
280	L1CLK Clock Period Normal Mode (see Note 1)	1800	2100	1800	2100	1800	2100	ns
281	L1CLK Width Low/High Normal Mode	840	1450	840	1450	840	1450	ns
282	L1CLK Rise/Fall Time Normal Mode (see Note 4)	—	—	—	—	—	—	ns
	L1CLK (GCI Clock) Period (MUX Mode) (see Note 1)	—	6.668	—	6.668	—	6.668	MHz
280	L1CLK Clock Period MUX Mode (see Note 1)	150	—	150	—	150	—	ns
281	L1CLK Width Low MUX Mode	55	—	55	—	55	—	ns
281A	L1CLK Width High MUX Mode (see Note 5)	P+10	—	P+10	—	P+10	—	ns
282	L1CLK Rise/Fall Time MUX Mode (see Note 4)	—	—	—	—	—	—	ns
283	L1SY1 Sync Setup Time to L1CLK Falling Edge	30	—	25	—	20	—	ns
284	L1SY1 Sync Hold Time from L1CLK Falling Edge	50	—	42	—	34	—	ns
285	L1TxD Active Delay (from L1CLK Rising Edge) (see Note 2)	0	100	0	85	0	70	ns
286	L1TxD Active Delay (from L1SY1 Rising Edge) (see Note 2)	0	100	0	85	0	70	ns
287	L1RxD Setup Time to L1CLK Rising Edge	20	—	17	—	14	—	ns
288	L1RxD Hold Time from L1CLK Rising Edge	50	—	42	—	34	—	ns
289	Time Between Successive L1SY1in	64 192	— —	64 192	— —	64 192	— —	L1CLK L1CLK
290	SDS1–SDS2 Active Delay from L1CLK Rising Edge (see Note 3)	10	90	10	75	7	60	ns
291	SDS1–SDS2 Active Delay from L1SY1 Rising Edge (see Note 3)	10	90	10	75	7	60	ns
292	SDS1–SDS2 Inactive Delay from L1CLK Falling Edge	10	90	10	75	7	60	ns
293	GCIDCL (GCI Data Clock) Active Delay	0	50	0	42	0	34	ns

NOTES:

1. The ratio CLKO/L1CLK must be greater than 2.5/1.
2. Condition $C_L = 150$ pF. L1TD becomes valid after the L1CLK rising edge or L1SY1, whichever is later.
3. SDS1–SDS2 become valid after the L1CLK rising edge or L1SY1, whichever is later.
4. Schmitt trigger used on input buffer.
5. Where $P = 1/CLKO$. Thus, for a 16.67-MHz CLKO rate, $P = 60$ ns.

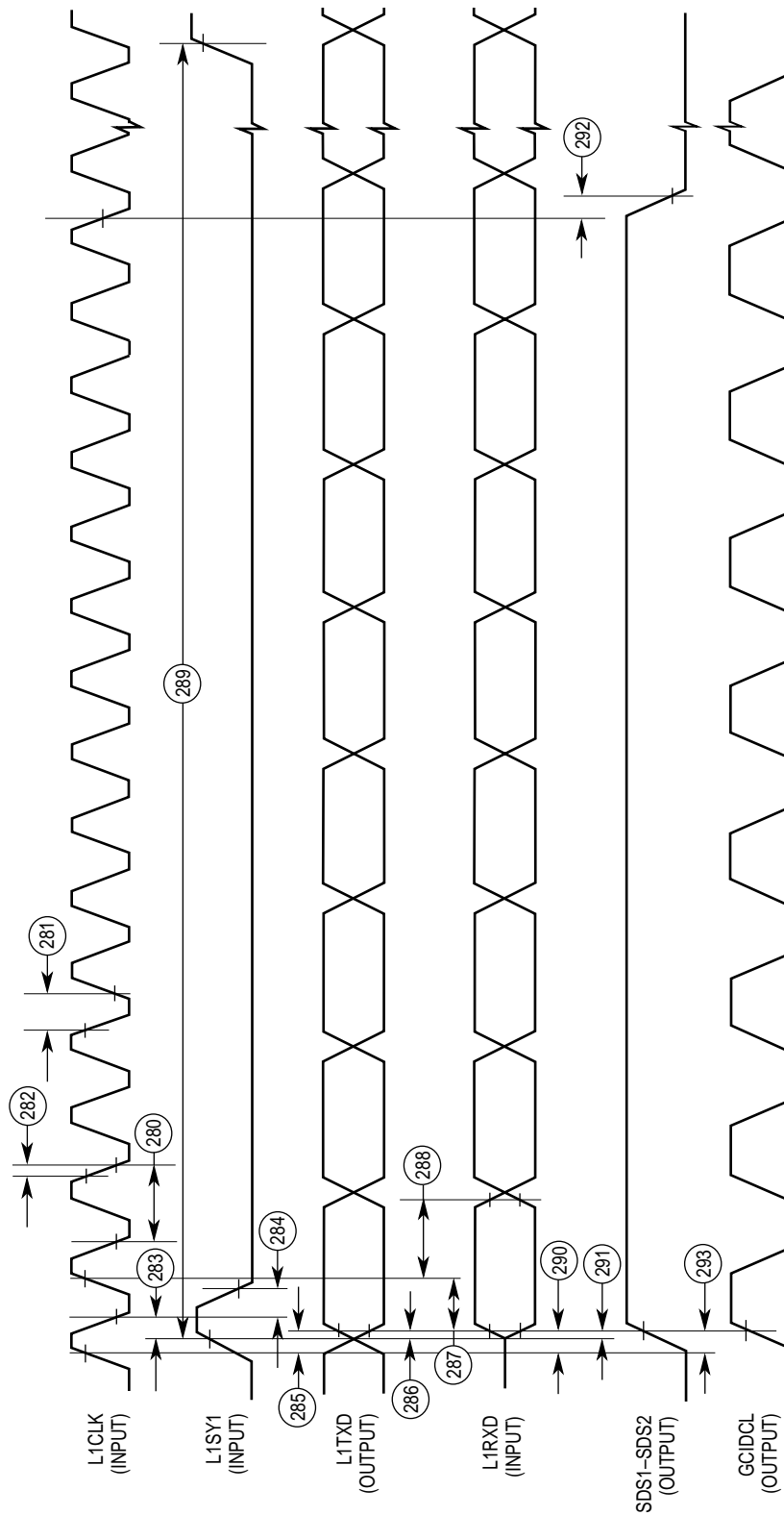

Figure 6-20. GCI Timing Diagram

6.21 AC ELECTRICAL SPECIFICATIONS—PCM TIMING

There are two sync types:

Short Frame—Sync signals are one clock cycle prior to the data

Long Frame—Sync signals are N-bits that envelope the data, $N > 0$; see Figure 6-21 and Figure 6-22).

Num.	Characteristic	16.67 MHz		20 MHz		25 MHz		Unit
		Min	Max	Min	Max	Min	Max	
300	L1CLK (PCM Clock) Frequency (see Note 1)	—	6.66	—	8.0	—	10.0	MHz
301	L1CLK Width Low	55	—	45	—	37	—	ns
301A	L1CLK Width High (see Note 4)	P+10	—	P+10	—	P+10	—	ns
302	L1SY0–L1SY1 Setup Time to L1CLK Rising Edge	0	—	0	—	0	—	ns
303	L1SY0–L1SY1 Hold Time from L1CLK Falling Edge	40	—	33	—	27	—	ns
304	L1SY0–L1SY1 Width Low	1	—	1	—	1	—	L1CLK
305	Time Between Successive Sync Signals (Short Frame)	8	—	8	—	8	—	L1CLK
306	L1TxD Data Valid after L1CLK Rising Edge (see Note 2)	0	70	0	60	0	47	ns
307	L1TxD to High Impedance (from L1CLK Rising Edge)	0	50	0	42	0	34	ns
308	L1RxD Setup Time (to L1CLK Falling Edge) (see Note 3)	20	—	17	—	14	—	ns
309	L1RxD Hold Time (from L1CLK Falling Edge) (see Note 3)	50	—	42	—	34	—	ns

NOTES:

1. The ratio CLK/L1CLK must be greater than 2.5/1.
2. L1TxD becomes valid after the L1CLK rising edge or the sync enable, whichever is later, if long frames are used.
3. Specification valid for both sync methods.
4. Where $P = 1/\text{CLKO}$. Thus, for a 16.67-MHz CLKO rate, $P = 60$ ns.

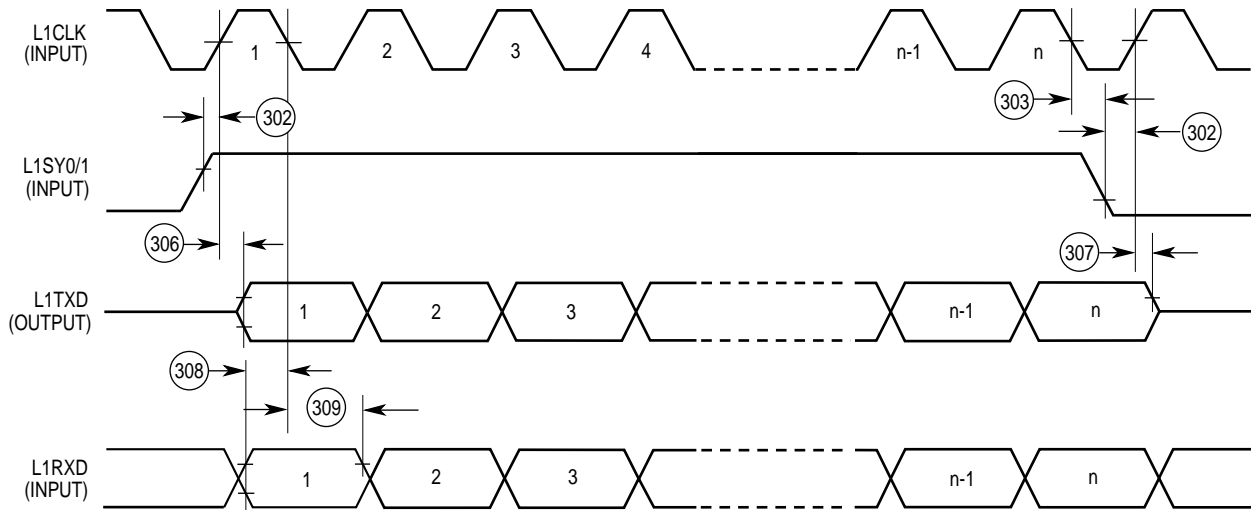
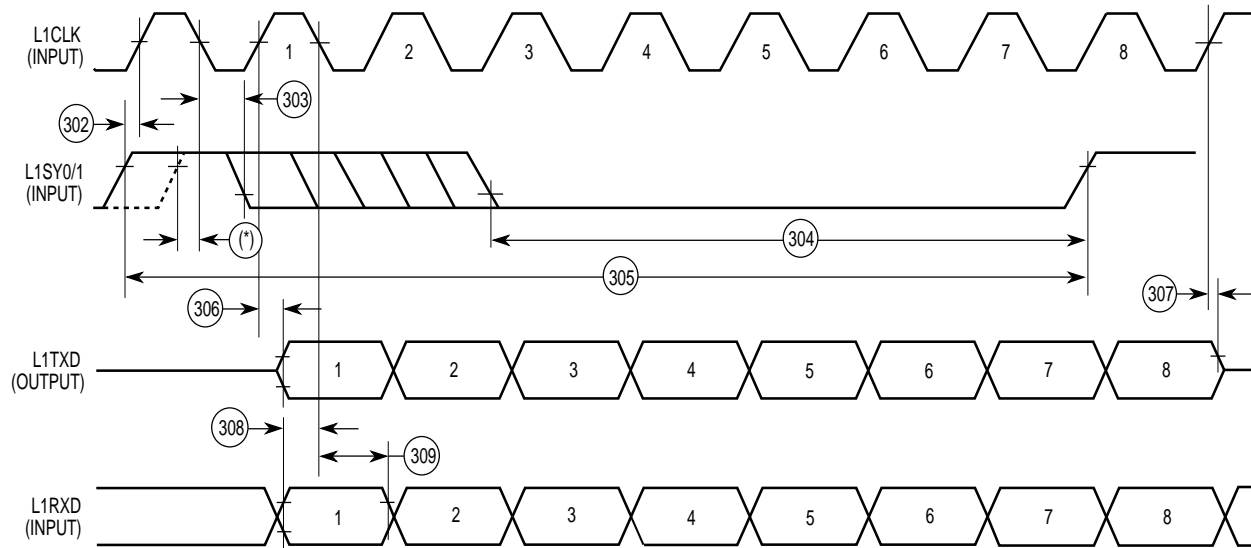

Figure 6-21. PCM Timing Diagram (SYNC Envelopes Data)



NOTE: (*) If L1SYn is guaranteed to make a smooth low to high transition (no spikes) while the clock is high, setup time can be defined as shown (min 20 ns).

Figure 6-22. PCM Timing Diagram (SYNC Prior to 8-Bit Data)

6.22 AC ELECTRICAL SPECIFICATIONS—NMSI TIMING

The NMSI mode uses two clocks, one for receive and one for transmit. Both clocks can be internal or external. When the clock is internal, it is generated by the internal baud rate generator and it is output on TCLK or RCLK. All the timing is related to the external clock pin. The timing is specified for NMSI1. It is also valid for NMSI2 and NMSI3 (see Figure 6-23).

Num.	Characteristic	16.67 MHz		16.67 MHz		20 MHz		20 MHz		25 MHz		25 MHz		Unit
		Internal Clock		External Clock		Internal Clock		External Clock		Internal Clock		External Clock		
		Min	Max	Min	Max	Min	Max	Min	Max	Min	Max	Min	Max	
315	RCLK1 and TCLK1 Frequency (see Note 1)	—	5.55	—	6.668	—	6.66	—	8	—	8.33	—	10	MHz
316	RCLK1 and TCLK1 Low (see Note 4)	65	—	P+10	—	55	—	P+10	—	45	—	P+10	—	ns
316a	RCLK1 and TCLK1 High	65	—	55	—	55	—	45	—	45	—	35	—	ns
317	RCLK1 and TCLK1 Rise/Fall Time (see Note 3)	—	20	—	—	—	17	—	—	—	14	—	—	ns
318	TXD1 Active Delay from TCLK1 Falling Edge	0	40	0	70	0	30	0	50	0	25	0	40	ns
319	$\overline{RTS1}$ Active/Inactive Delay from TCLK1 Falling Edge	0	40	0	100	0	30	0	80	0	25	0	65	ns
320	$\overline{CTS1}$ Setup Time to TCLK1 Rising Edge	50	—	10	—	40	—	7	—	35	—	7	—	ns
321	RXD1 Setup Time to RCLK1 Rising Edge	50	—	10	—	40	—	7	—	35	—	7	—	ns
322	RXD1 Hold Time from RCLK1 Rising Edge (see Note 2)	10	—	50	—	7	—	40	—	7	—	35	—	ns
323	$\overline{CD1}$ Setup Time to RCLK1 Rising Edge	50	—	10	—	40	—	7	—	35	—	7	—	ns

NOTES:

1. The ratio CLKO/TCLK1 and CLKO/RCLK1 must be greater than or equal to 2.5/1 for external clock. The input clock to the baud rate generator may be either an internal clock or TIN1, and may be as fast as EXTAL. However, the output of the baud rate generator must provide a CLKO/TCLK1 and CLKO/RCLK1 ratio greater than or equal to 3/1. In asynchronous mode (UART), the bit rate is 1/16 of the TCLK1/RCLK1 clock rate.
2. Also applies to \overline{CD} hold time when \overline{CD} is used as an external sync in BISYNC or totally transparent mode.
3. Schmitt triggers used on input buffers.
4. Where $P = 1/CLKO$. Thus, for a 16.67-MHz CLKO rate, $P = 60$ ns.

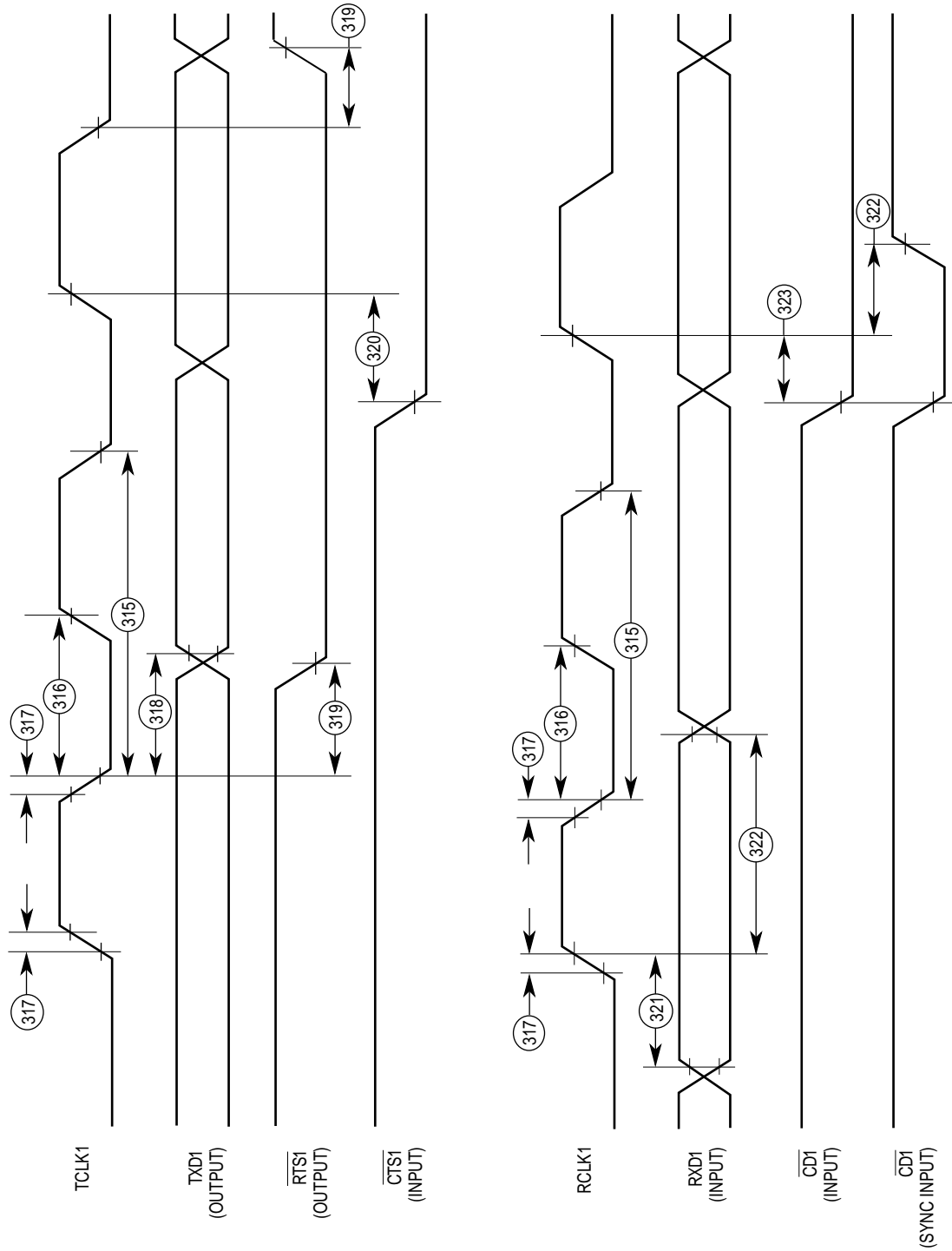
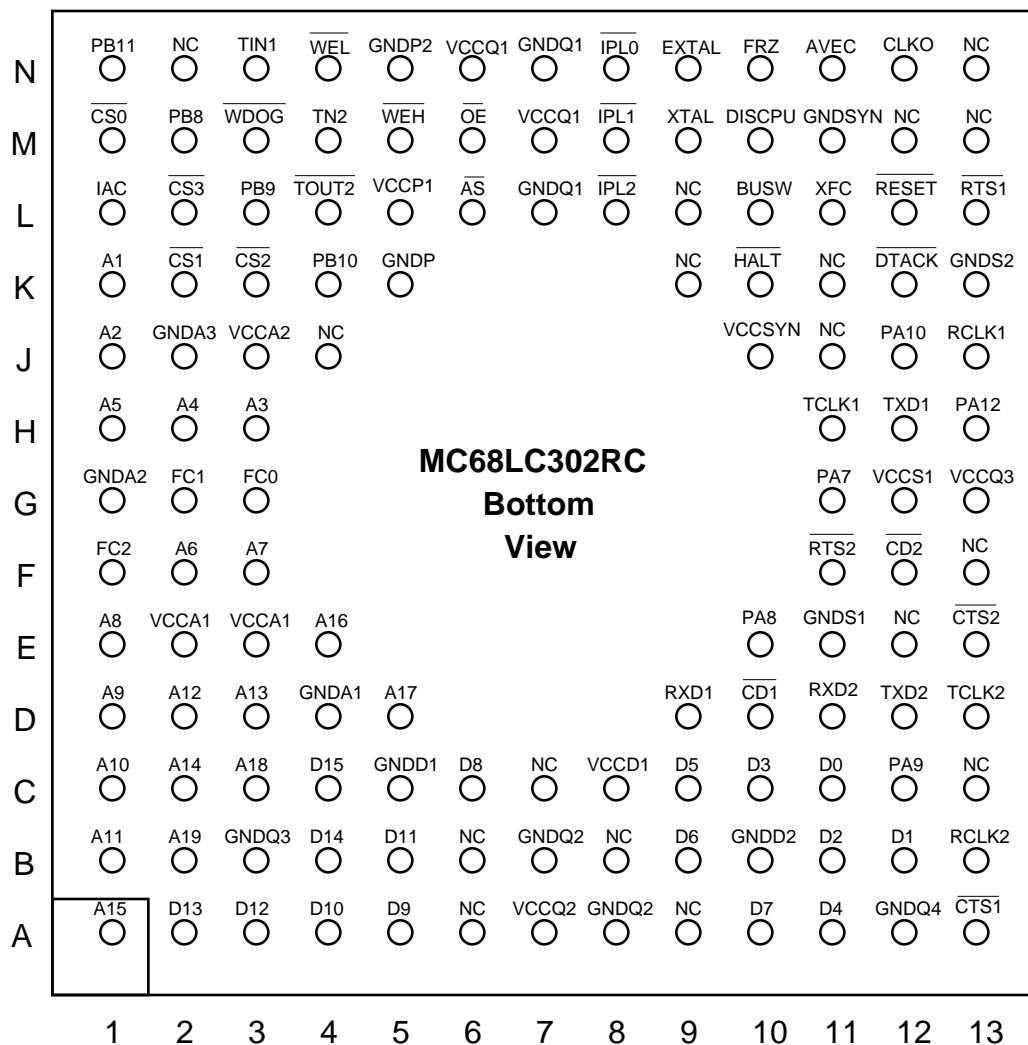

Figure 6-23. NMSI Timing Diagram

SECTION 7 MECHANICAL DATA AND ORDERING INFORMATION

7.1 PIN ASSIGNMENTS

7.1.1 Pin Grid Array (PGA)



7.1.2 Surface Mount (TQFP)

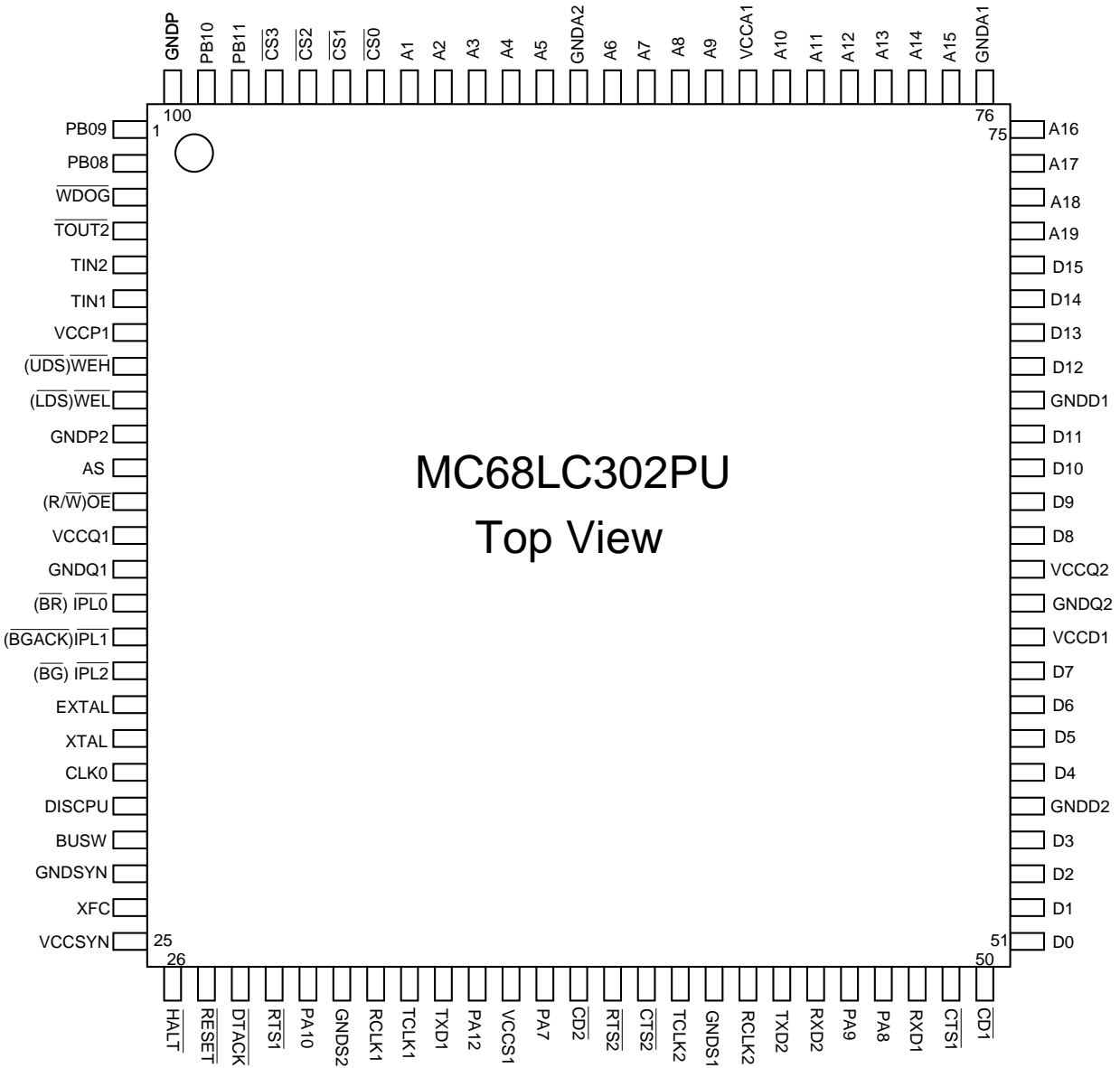

7.2 PACKAGE DIMENSIONS

7.2.1 Pin Grid Array (PGA)

MC68EC030
RP SUFFIX PACKAGE
CASE 789B-01

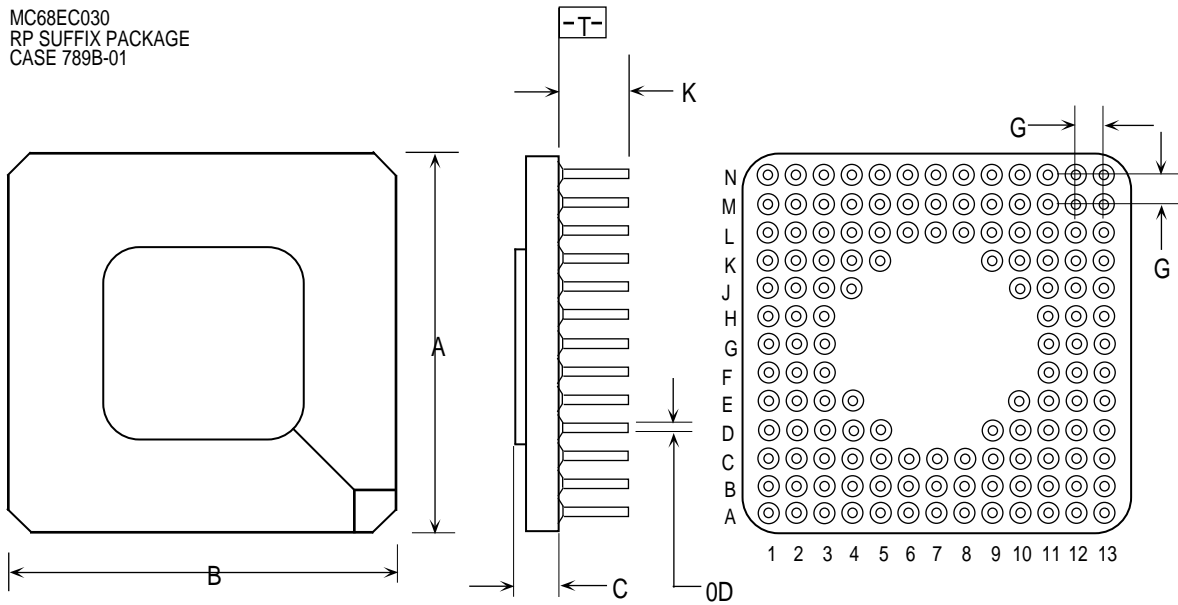

DIM	MILLIMETERS		INCHES	
	MIN	MAX	MIN	MAX
A	34.04	35.05	1.340	1.380
B	34.04	35.05	1.340	1.380
C	2.54	3.81	0.100	0.150
D	0.43	0.55	0.017	0.022
G	2.54 BSC		0.100 BSC	
K	4.32	4.95	0.170	0.195

NOTES:

1. A AND B ARE DATUMS AND T IS A DATUM SURFACE.
2. POSITIONAL TOLERANCE FOR LEADS (132 PL).

3. $\phi 0.13 (0.005) \text{ (M)}$ T A (S) B (S) 14.5M, 1982.

4. CONTROLLING DIMENSION: INCH.

7.2.2 Surface Mount (TQFP)

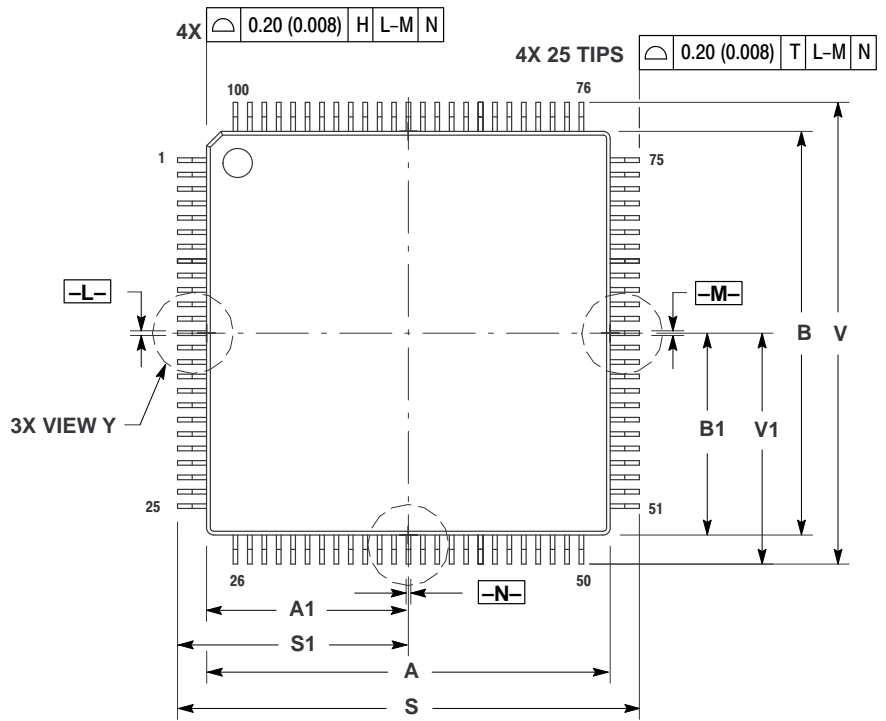

NOTES:

1. DIMENSIONING AND TOLERANCING PER ANSI Y14.5M, 1982.
2. CONTROLLING DIMENSION: MILLIMETER.
3. DATUM -H- IS LOCATED AT BOTTOM OF LEAD AND IS COINCIDENT WITH THE LEAD WHERE THE LEAD EXITS THE PLASTIC BODY AT THE BOTTOM OF THE PARTING LINE.
4. DATUMS -L-, -M- AND -N- TO BE DETERMINED AT DATUM -H-.
5. DIMENSIONS S AND V TO BE DETERMINED AT SEATING PLANE -T-.
6. DIMENSIONS A AND B DO NOT INCLUDE MOLD PROTRUSION. ALLOWABLE PROTRUSION IS 0.250 (0.100) PER SIDE. DIMENSIONS A AND B DO INCLUDE MOLD MISMATCH AND ARE DETERMINED AT DATUM -H-.
7. DIMENSION D DOES NOT INCLUDE DAMBAR PROTRUSION. DAMBAR PROTRUSION SHALL NOT CAUSE THE LEAD WIDTH TO EXCEED 0.350 (0.014). MINIMUM SPACE BETWEEN PROTRUSION AND ADJACENT LEAD OR PROTRUSION 0.070 (0.003).

DIM	MILLIMETERS		INCHES	
	MIN	MAX	MIN	MAX
A	14.00	BSC	0.551	BSC
A1	7.00	BSC	0.276	BSC
B	14.00	BSC	0.551	BSC
B1	7.00	BSC	0.276	BSC
C	—	1.60	—	0.063
C1	0.05	0.15	0.002	0.006
C2	1.35	1.45	0.053	0.057
D	0.17	0.27	0.007	0.011
E	0.45	0.75	0.018	0.030
F	0.17	0.23	0.007	0.009
G	0.50	BSC	0.20	BSC
J	0.09	0.20	0.004	0.008
K	0.50	REF	0.020	REF
R1	0.10	0.20	0.004	0.008
S	16.00	BSC	0.630	BSC
S1	8.00	BSC	0.315	BSC
U	0.09	0.16	0.004	0.006
V	16.00	BSC	0.630	BSC
V1	8.00	BSC	0.315	BSC
W	0.20	REF	0.008	REF
Z	1.00	REF	0.039	REF
θ	0°	7°	0°	7°
θ1	0°	—	0°	—
θ2	12°	—	12°	—
θ3	5°	13°	5°	13°

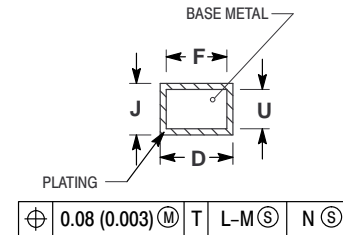
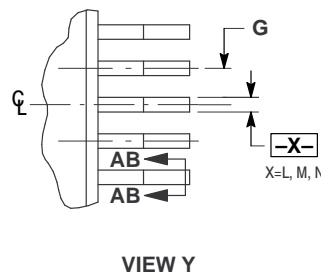
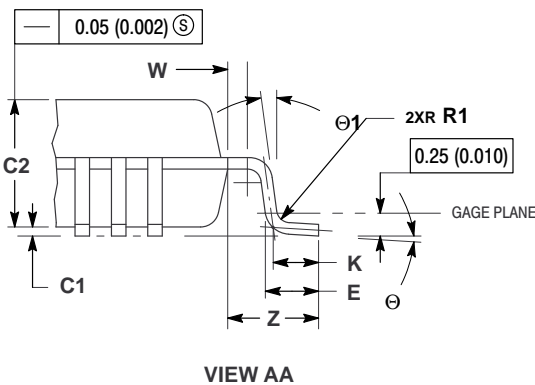
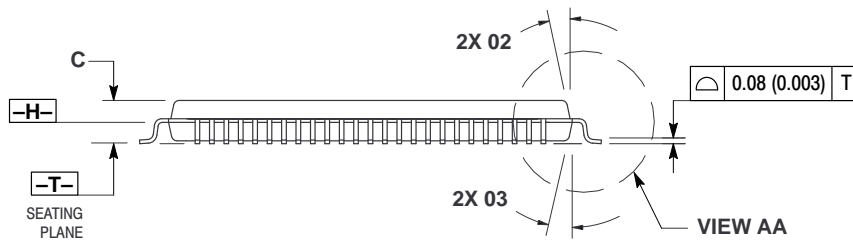

SECTION AB-AB
ROTATED 90° CLOCKWISE

CASE 983-01
ISSUE A

DATE 07/14/94

7.3 ORDERING INFORMATION

Package Type	Frequency (MHz)	Temperature	Order Number
Pin Grid Array (RC Suffix)	16.67 16.67 20 20	0°C to 70°C - 40°C to + 85°C 0°C to 70°C - 40°C to + 85°C	MC68LC302RC16 MC68LC302CRC16 MC68LC302RC20 MC68LC302CRC20
Surface Mount (PU Suffix)	16.67 20	0°C to 70°C 0°C to 70°C	MC68LC302PU16 MC68LC302PU20

INDEX

A

- Address
 - AS 3-25
 - Decode
 - Conflict 2-4
 - Decode Conflict 3-3, 3-4
- Address Bus Pins 5-7
- AS 3-3, 3-25, 5-9
- AT command set 4-9
- Autobaud Controller 4-9
 - Autobaud Command Descriptor 4-14
 - Autobaud Lookup Table Format 4-16
 - Autobaud Parameter RAM 4-11
 - Autobaud Sampling Rate 4-15
 - Autobaud Transmission 4-18
 - Automatic Echo 4-19
 - Carrier Detect Lost 4-18
 - Channel Reception Process 4-9
 - Determining Character Length and Parity 4-17
 - End Of Table Error 4-18
 - Enter_Baud_Hunt Command 4-14
 - Lookup Table 4-15
 - Lookup Table Example 4-17
 - Lookup Table Pointer 4-15
 - Lookup Table Size 4-15
 - Maximum START bit length 4-16
 - Overrun Error 4-18
 - Performance 4-9
 - Preparing for the Autobaud Process 4-13
 - Programming Model 4-13
 - Reception Error Handling Procedure 4-18
 - Reprogramming to UART Mode or another protocol 4-20
 - Smart Echo 4-11, 4-19
 - Smart Echo Hardware Setup 4-11
 - START bit 4-9
 - Transmit Process 4-11
- Automatic echo 4-5

B

- Base Address Register 2-4
- Baud Rate Generator 5-18
- BCR 3-13
- BERR 2-4, 3-3, 3-4, 3-5, 3-6
- BERR See Signals
- BG 3-28, 5-11
- BGACK 5-11
- BISYNC Controller 4-22
 - BISYNC Event Register 4-23
 - BISYNC Mask Register 4-23
 - BISYNC Memory Map 4-22
 - BISYNC Mode Register 4-22
 - BISYNC Receive Buffer Descriptor 4-22
 - BISYNC Transmit Buffer Descriptor 4-22
- Bootstrap 3-7
- BR 3-28, 3-29, 5-10
- BR3–BR0 3-26
- BRG 2-12
- BRG Clock 2-12
- BRG Divide by two
 - System Clock 2-14
- BSR 3-6
- Buffer
 - Buffer Descriptor 4-6
 - Descriptors 2-20, 3-29
- Buffer Descriptor 4-6
- Buffer Descriptors Table 4-6
- Bus
 - Arbitration 3-28, 5-11
 - Bandwidth 3-12
 - Error 2-4
 - Grant (BG) 5-11
 - Grant Acknowledge (BGACK) 5-11
 - Master 3-28
 - Request (BR) 5-10
 - Signal Summary 5-13
- Bus Arbitration Logic 3-28
 - External Bus Arbitration 3-28
 - Internal Bus Arbitration 3-28

Bus Arbitration Pins 5-10
Bus Control Pins 5-9
Bus States during Low power modes
 68000 2-15
BUSW 2-1, 5-7

C

Changes to IMP
 CLKO Drive Options 2-6
 Three-state TCLK1 2-6
 Three-state RCLK1 2-6
Chip-Select 2-4
 AS 3-25
 Base Address 3-27
 Base Register 3-26
 CS0 3-26, 3-28, 5-21
 DTACK 3-26
 Option Register 3-26
Chip-Select Pins 5-21
Chip-Select Registers 3-26
Chip-Select Timing 6-24
CLKO
 Output Buffer Strength 2-11
CLKOMOD1–2 2-6
Clock
 CLKO 5-4
Clock Pins 5-4
CMOS Level 5-2
CMR 3-11
Communications Processor 4-1
Configuration
 MC68302 IMP Control 2-3
CQFP 7-2
Crystal Oscillator 2-8
Crystal Oscillator Circuit (IMP) 2-9
CS0 3-26, 3-28, 5-21
CS1 2-23, 2-24, 5-21
CS2 2-23, 2-24
CS3 2-23, 3-26, 5-1, 5-10, 5-21
CS3–CS1 5-21
CSelect 2-7
CSR 3-13

D

DAPR 3-13
Data Bus Pins 5-8
Default System Clock Generation 2-7

DF0–3 2-10
Disable CPU 5-7
 BG 3-28
 BR 3-28
 CS0 3-28
 DTACK 3-28
 EMWS 3-28
 SAM 3-28
Disable CPU Logic 3-28
Disable SCC1 Serial Clocks Out 4-4
DISC 4-4
DISCPU 3-28, 5-7
Divide by Two Block
 From Tin1 pin 4-5
DMA Control 3-10
DOZE 2-13, 2-16
DRAM Refresh
 Buffer Descriptors 3-29
 PB8 3-18
Drive 2-13
DSR 4-6
DTACK 3-4, 3-26, 3-28, 5-10, 5-12
Dynamic RAM Refresh Controller 3-29

E

EMWS (External Master Wait State) 3-4, 3-5,
 3-28
Enable Receiver 4-5
Enable Transmitter 4-6
Exception
 PB8 3-29
EXTAL 5-2, 5-4
External
 Bus Master 3-28
 External Bus Arbitration using HALT 3-28
 Master Wait State (EMWS) 3-5
External Bus Arbitration 3-28
External Master Wait State 3-4

F

FCR 3-13
Freeze Control 3-5
FRZ 5-7
Function Codes 3-13, 5-12
 Comparison 2-4
 FC2-FC0 2-4, 5-12
 Register 3-13

G

GCI 4-2, 5-14, 5-15
 SCIT 4-2
 SIMASK 4-4
 SIMODE 4-2
 GCI See Signals
 GIMR 3-14
 GNDSYN 2-12, 5-5

H

HALT 2-4, 5-6
 HALT See Signals
 Hardware Watchdog 3-5
 BERR 3-5, 3-6
 HDLC
 HDLC Event Register 4-21
 HDLC Mask Register 4-21
 HDLC Memory Map 4-20
 HDLC Mode Register 4-20
 Rx BD 4-21
 SCCE 4-21
 SCCM 4-21
 Tx BD 4-21
 HDLC Controller 4-20
 HDLC Event Register 4-21
 HDLC Mask Register 4-21
 HDLC Memory Map 4-20
 HDLC Mode Register 4-20
 HDLC Receive Buffer Descriptor 4-21
 HDLC Transmit Buffer Descriptor 4-21

I

IAC 5-10
 IDL 4-2, 5-14, 5-15
 SIMASK 4-4
 SIMODE 4-2
 IDL See Signals
 IDMA (Independent DMA Controller)
 DREQ 3-11
 IMP Features
 CP 1-2
 IMP Operation Mode Control Register
 (IOMCR) 2-14, 2-15
 IMP PLL and Clock Control Register
 (IPLCR) 2-10
 IMP PLL Pins 2-12

GNDSYN 2-12
 MODCLK 2-12
 VCCSYN 2-12
 XFC 2-12

IMP System Clock Generation
 IOMCR 2-8, 2-9, 2-10
 IPLCR 2-8, 2-10
 IMP System Clocks Schematic
 PLL Disabled 2-8
 IMP Wake-Up from Low Power STOP
 Modes 2-17
 IMR 3-16
 Internal Loopback 4-3
 Internal Registers 2-22
 Internal Registers Map 2-23
 Interrupt
 Acknowledge 2-4
 Control Pins 5-11
 Controller 3-14
 IPR 3-15
 ISR 3-16
 Interrupt Control Pins 5-11
 Interrupt Controller 3-14
 IOMCR 2-7, 2-14, 2-16
 IPL 5-11
 IPL0 5-11
 IPL1 5-11
 IPL2 5-11
 IPL2-IPL0 5-11
 IPLCR 2-7, 2-10
 IPR 3-15
 IPWRD 2-15
 IRQ1 5-12
 ISDN 5-14
 ISR 3-16
 IWUCR 2-17

L

Loopback Control 4-3
 Loopback Mode
 Internal Loopback 4-3
 Loopback Control 4-3
 Loopback mode 4-5
 Low Power 2-13
 68000 bus 2-13
 Low Power Drive Control Register 2-13
 Low Power Drive Control Register (LPDCR)

2-15
 Low Power Modes
 IMP 2-13
 Low Power Support 2-15
 FAST WAKE-UP 2-18
 STOP/ DOZE/ STAND_BY Mode 2-16
 Wake-Up from Low Power STOP Modes
 2-17
 Low-Power Clock Divider 2-9
 LPDCR 2-15
 LPM1-0 2-15

M

MC68000/MC68008 Modes 2-1
 MC68LC302 System Clock Generation
 IOMCR 2-6
 IPLCR 2-6
 IWUCR 2-6
 MODCLK 2-7
 PITR 2-6
 VCCSYN 2-7
 MF 11-0 2-11
 MODCLK 2-12
 MODCLK/PA12 5-5
 MODCLK1-0 2-7
 Multiplication Factor 2-11

N

NMSI 4-2, 5-14
 CD1 5-16
 CTS1 5-17
 NMSI1 5-15
 NMSI2 5-17
 NMSI3 5-18
 RTS1 5-17
 SIMODE 4-2
 NMSI1 or ISDN Interface Pins 5-14
 NMSI2 Port or Port a Pins 5-17
 Normal Operation 4-5

O

OE (R/W) 5-9
 OR3-OR0 3-26
 Oscillator 2-8

P

PACNT 3-19
 PADDR 3-19
 PAIO / SCP Pins 5-18
 Parallel 5-20
 Parallel I/O Pins with Interrupt Capability 5-20
 Parallel I/O Port
 PB11 3-18
 PB8 3-18, 3-29
 Port A 3-17, 5-17, 5-18
 Control Register 3-17
 Data Direction Register (PADDR) 3-17
 Port B 3-17, 5-20
 Control Register 3-18
 Parallel I/O Ports 3-17
 Parameter RAM 2-21
 PB11 3-18
 PB11 See DRAM Refresh
 PB11 See Parallel I/O Port
 PB8 3-18, 3-29
 PBCNT 3-18, 3-19
 PBDAT 3-20
 PBDDR 3-18, 3-20
 PCM 4-2
 PCM Highway 5-14, 5-15
 SIMODE 4-2
 Periodic Timer Period Calculation 3-23
 Physical Layer Serial Interface Pins 5-14
 Pin Assignments 7-1
 Pin Grid Array 7-1
 PIT 2-11, 2-12, 3-22
 As a Real-Time Clock 3-24
 Period Calculation 3-23
 PIT Clock 2-12
 PITR 3-24
 PLL 2-10
 PLL and Oscillator Changes to IMP 2-5
 CLKO Drive Options 2-6
 Three-State RCLK1 2-6
 Three-State TCLK1 2-6
 PLL Clock Divider 2-10
 PLL External Components 2-9
 PLL Pins
 pgnd 5-5
 pinit 2-7

PNDAT 3-20
 PNDDR 3-20
 Port A 3-17
 Port A Pin Functions 3-18
 Port A Pin Functions 3-18
 Port A/B
 Parallel I/O 3-17
 Port B 3-18
 Port B Pin Functions 3-18
 Port N 3-19
 PADAT 3-19
 Power Dissipation 6-4
 Power Pins 5-2
 Programmable Data Bus Size Switch 3-6
 Protocol Parameters 2-20
 Pullup Resistors 5-21

R

RCLK1
 Disabling 4-5
 RCLK1/L1CLK 5-16
 Read-Modify-Write Cycle 6-12
 Real-Time Clock 3-24
 Registers
 Internal 2-22
 Interrupt In-Service (ISR) 3-16
 Interrupt Pending (IPR) 3-15
 Port A
 Control (PACNT) 3-17
 Data Direction (PADDDR) 3-17
 Port B
 Data Direction Register (PBDDR) 3-18
 System Control (SCR) 2-4
 Reprogramming to UART Mode or Another Protocol 4-20
 RESET 5-6, 5-20
 Instruction 2-3
 Reset
 SMC Memory Structure 4-26
 Total System 2-3
 Revision Number 2-20
 Ring Oscillator 2-18
 Ringo 2-18
 RINGOCR 2-19
 RINGOEVR 2-20
 RMC 3-4

RXD1/L1RXD 5-15

S

SAM 3-4, 3-28
 SAPR 3-13
 SCC 2-20
 Buffer Descriptor 4-6
 DSR 4-6
 Enable Receiver 4-5
 Normal Operation 4-5
 SCON 4-4
 Software Operation 4-5
 TIN1/TIN2 5-20
 SCC Mode Register 4-5
 SCC Parameter RAM 4-7
 SCC Parameter RAM Memory Map 4-7
 SCCs 4-4
 SCIT 4-2
 SCM 4-5
 SCON 4-4
 SCP 2-20
 Serial Communication Port 4-25
 SCP Port 5-19
 SCR 3-2
 SCR (System Control Register) 2-4
 SCR Register Bits 3-2
 Serial Channels Physical Interface 4-2
 Serial Communication Controllers 4-4
 Serial Communication Port 4-25, 6-29
 Serial Management Controllers 4-26
 SMC1 Receive Buffer Descriptor 4-26
 SMC1 Transmit Buffer Descriptor 4-26
 SMC2 Receive Buffer Descriptor 4-27
 SMC2 Transmit Buffer Descriptor 4-27
 Signals
 AS 3-3, 3-25
 BERR 2-4, 3-3, 3-4, 3-5, 3-6
 BG 3-28, 5-11
 BGACK 5-11
 BR 3-28, 3-29, 5-10
 BUSW 2-1, 5-7
 CD1 5-16
 CLKO 5-4
 CS 2-4, 3-3
 CS0 3-26, 3-28, 5-21
 CTS1 5-17
 DISCPU 3-28, 5-7

DREQ 3-11
DTACK 3-4, 3-26, 3-28, 5-12
EXTAL 5-2, 5-4
FC2-FC0 5-12
GCI 5-15
HALT 2-4, 5-6
IAC 5-10
IDL 5-15, 5-17
ILP0 5-11
IRQ1 5-12
NMSI2 5-17
NMSI3 5-18
PCM Highway 5-15
Port A 5-17, 5-18
Port B 5-20
RESET 2-3, 5-6, 5-20
RMC 3-4
RTS1 5-17
SCP 5-19
TIN1/TIN2 5-20
WDOG 3-18, 5-20
XTAL 5-4
SIMASK 4-2, 4-4
SIMODE 4-2
SLOW_GO 2-10, 2-13, 2-14, 2-15
SLOW_GO Mode 2-14
SMC 2-20
 Serial Management Controllers 4-26
SMC Memory Structure 4-26
Software Operation 4-5
Software Watchdog Timer 3-22
STAND_BY 2-13, 2-16
STAND_BY Mode 2-13
STOP 2-13, 2-16
STOP Mode 2-13
Supervisor
 Data Space 2-3
System Control Registers (SCR) 2-4
System Clock
 IMP 2-12
System Control 3-1
System Control Bits 3-3
System Control Pins 5-5
System Control Register (SCR) 3-2
System Status Bits 3-3

T

TCLK1
 Disabling 4-5
TCLK1/L1SY0/SDS1 5-16
TCN1, TCN2 3-21
TCR1, TCR2 3-21
TER1, TER2 3-21
Thermal Characteristics 6-2
Timer
 PIT 3-22
Timer Pins 5-19
Timers 3-20
 TIN1/TIN2 5-20
 WDOG 3-18, 3-22
TIN1/TIN2 5-20
TIN1/TIN2 See SCC
TMR1, TMR2 3-20
Transparent Controller 4-23
 Transparent Event Register 4-25
 Transparent Mask Register 4-25
 Transparent Mode Register 4-24
 Transparent Receive Buffer Descriptor
 4-24
 Transparent Transmit Buffer Descriptor
 4-25
TRR1, TRR2 3-21
TTL Levels 5-2
TXD1/L1TXD 5-15

U

UART Controller 4-7
 UART Event Register 4-9
 UART Mask Register 4-9
 UART Memory Map 4-7
 UART Mode Register 4-8
 UART Receive Buffer Descriptor 4-8
 UART Transmit Buffer Descriptor 4-8

V

VCCSYN 2-12, 5-5
VCO 2-10, 2-11
Vector Generation Enable 3-5

W

Wake_Up
 Clock cycles, IMP 2-13

Wake-up
 PB10 2-18
 PIT 2-18
 PIT Event 2-18
Watchdog (WDOG) 3-18, 5-20
 Hardware 3-5
 Timer 3-22
Watchdog (WDOG) See Signals
Watchdog (WDOG) See Timers
WCN 3-22
WEH (UDS/A0) 5-9
WEL (LDS/DS) 5-10
Write Protect Violation 3-3
WRR 3-22

X

XFC 2-12, 5-5
XTAL 5-4

