

## FEATURES

- Complete DS1/ISDN-PRI/J1 transceiver functionality
- Long and Short haul LIU
- Crystal-less jitter attenuator
- Generates DSX-1 and CSU line build-outs
- HDLC controller with 64-byte buffers Configurable for FDL or DS0 operation
- Dual two-frame elastic store slip buffers that can connect to asynchronous backplanes up to 8.192MHz
- 8.192MHz clock output locked to RCLK
- Interleaving PCM Bus Operation
- Per-channel loopback and idle code insertion
- 8-bit parallel control port muxed or nonmuxed buses (Intel or Motorola)
- Programmable output clocks for Fractional T1
- Fully independent transmit and receive functionality
- Generates/detects in-band loop codes from 1 to 8 bits in length including CSU loop codes
- IEEE 1149.1 JTAG-Boundary Scan
- Pin compatible with DS2152/54/354/554 SCTs
- 100-pin LQFP package (14 mm x 14 mm) 3.3V (DS21352) or 5V (DS21552) supply; low power CMOS

## PIN ASSIGNMENT

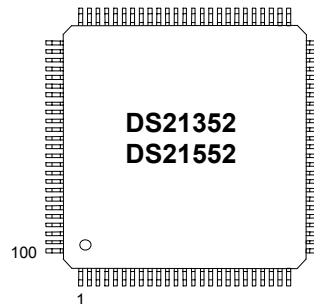

## ORDERING INFORMATION

DS21352L	(0°C to +70°C)
DS21352LN	(-40°C to +85°C)
DS21552L	(0°C to +70°C)
DS21552LN	(-40°C to +85°C)

## DESCRIPTION

The DS21352/552 T1 single-chip transceiver contains all of the necessary functions for connection to T1 lines whether they are DS1 long haul or DSX-1 short haul. The clock recovery circuitry automatically adjusts to T1 lines from 0 feet to over 6000 feet in length. The device can generate both DSX-1 line build outs as well as CSU line build-outs of -7.5dB, -15dB, and -22.5dB. The onboard jitter attenuator (selectable to either 32 bits or 128 bits) can be placed in either the transmit or receive data paths. The framer locates the frame and multiframe boundaries and monitors the data stream for alarms. It is also used for extracting and inserting robbed-bit signaling data and FDL data. The device contains a set of internal registers which the user can access and control the operation of the unit. Quick access via the parallel control port allows a single controller to handle many T1 lines. The device fully meets all of the latest T1 specifications including ANSI T1.403-1995, ANSI T1.231-1993, AT&T TR 62411 (12-90), AT&T TR54016, and ITU G.703, G.704, G.706, G.823, and I.431.

## TABLE OF CONTENTS

<b>1.</b>	<b>LIST OF FIGURES .....</b>	<b>5</b>
<b>2.</b>	<b>LIST OF TABLES .....</b>	<b>6</b>
<b>3.</b>	<b>INTRODUCTION.....</b>	<b>7</b>
	3.1 FUNCTIONAL DESCRIPTION.....	8
	3.2 DOCUMENT REVISION HISTORY.....	10
<b>4.</b>	<b>PIN DESCRIPTION .....</b>	<b>11</b>
	4.1 PIN FUNCTION DESCRIPTION.....	17
	4.1.1 <i>Transmit Side Pins</i> .....	17
	4.1.2 <i>Receive Side Pins</i> .....	20
	4.1.3 <i>Parallel Control Port Pins</i> .....	23
	4.1.4 <i>JTAG Test Access Port Pins</i> .....	25
	4.1.5 <i>Interleave Bus Operation Pins</i> .....	25
	4.1.6 <i>Line Interface Pins</i> .....	26
	4.1.7 <i>Supply Pins</i> .....	27
<b>5.</b>	<b>PARALLEL PORT .....</b>	<b>28</b>
	5.1 REGISTER MAP .....	28
<b>6.</b>	<b>CONTROL, ID, AND TEST REGISTERS .....</b>	<b>32</b>
	6.1 POWER-UP SEQUENCE.....	32
	6.2 DEVICE ID .....	32
	6.3 PAYLOAD LOOPBACK.....	37
	6.4 FRAMER LOOPBACK .....	38
	6.5 PULSE DENSITY ENFORCER.....	40
	6.6 REMOTE LOOPBACK .....	44
<b>7.</b>	<b>STATUS AND INFORMATION REGISTERS.....</b>	<b>45</b>
<b>8.</b>	<b>ERROR COUNT REGISTERS .....</b>	<b>52</b>
	8.1 LINE CODE VIOLATION COUNT REGISTER (LCVCR) .....	53
	8.2 PATH CODE VIOLATION COUNT REGISTER (PCVCR).....	54
	8.3 MULTIFRAMES OUT OF SYNC COUNT REGISTER (MOSCR).....	55
<b>9.</b>	<b>DSD MONITORING FUNCTION.....</b>	<b>56</b>

<b>10. SIGNALING OPERATION.....</b>	<b>58</b>
10.1 PROCESSOR-BASED SIGNALING .....	58
10.2 HARDWARD-BASED SIGNALING .....	60
10.2.1 Receive Side.....	60
10.2.2 Transmit Side.....	61
<b>11. PER-CHANNEL CODE (IDLE) GENERATION .....</b>	<b>61</b>
11.1 TRANSMIT SIDE CODE GENERATION .....	62
11.1.1 Fixed Per-Channel Idle Code Insertion .....	62
11.1.2 Unique Per-Channel Idle Code Insertion.....	63
11.2 RECEIVE SIDE CODE GENERATION.....	63
11.2.1 Fixed Per-Channel Idle Code Insertion .....	64
11.2.3 Unique Per-Channel Idle Code Insertion.....	64
<b>12. PER-CHANNEL LOOPBACK.....</b>	<b>65</b>
<b>13. CLOCK BLOCKING REGISTERS .....</b>	<b>65</b>
<b>14. ELASTIC STORES OPERATION .....</b>	<b>66</b>
14.1 RECEIVE SIDE .....	66
14.2 TRANSMIT SIDE.....	67
14.3 ELASTIC STORES INITIALIZATION .....	67
14.4 MINIMUM DELAY MODE.....	67
<b>15. HDLC CONTROLLER.....</b>	<b>68</b>
15.1 HDLC FOR DS0S .....	68
15.1.1 Receive an HDLC Message.....	68
15.1.2 Transmit an HDLC Message.....	68
15.2 FDL/Fs EXTRACTION AND INSERTION .....	69
15.3 HDLC and BOC CONTROLLER FOR THE FDL.....	69
15.3.1 General Overview.....	69
15.3.2 Status Register for the HDLC.....	70
15.3.3 Basic Operation Details .....	71
15.3.4 HDLC/BOC Register Description .....	72
15.4 LEGACY FDL SUPPORT .....	82
15.4.1 Overview.....	82
15.4.2 Receive Section.....	82
15.4.3 Transmit Section.....	84
15.5 D4/SLC-96 OPERATION.....	84

---

<b>16.</b>	<b>LINE INTERFACE FUNCTION .....</b>	<b>85</b>
16.1	RECEIVE CLOCK AND DATA RECOVERY .....	85
16.2	TRANSMIT WAVE SHAPING AND LINE DRIVING.....	86
16.3	JITTER ATTENUATOR.....	86
16.4	PROTECTED INTERFACES.....	92
16.5	RECEIVE MONITOR MODE.....	95
<b>17.</b>	<b>PROGRAMMABLE IN-BAND LOOP CODE GENERATION AND DETECTION.....</b>	<b>96</b>
<b>18.</b>	<b>TRANSMIT TRANSPARENCY.....</b>	<b>99</b>
<b>19.</b>	<b>JTAG-BOUNDARY SCAN ARCHITECTURE AND TEST ACCESS PORT .....</b>	<b>99</b>
19.1	DESCRIPTION .....	99
19.2	TAP CONTROLLER STATE MACHINE.....	101
19.3	INSTRUCTION REGISTER .....	103
19.4	TEST REGISTERS .....	105
<b>20.</b>	<b>INTERLEAVED PCM BUS OPERATION .....</b>	<b>109</b>
20.1	CHANNEL INTERLEAVE .....	111
20.2	FRAME INTERLEAVE.....	111
<b>21.</b>	<b>FUNCTIONAL TIMING DIAGRAMS .....</b>	<b>111</b>
<b>22.</b>	<b>RECEIVE AND TRANSMIT DATA FLOW DIAGRAMS.....</b>	<b>123</b>
<b>23.</b>	<b>OPERATING PARAMETERS.....</b>	<b>125</b>
<b>24.</b>	<b>AC TIMING PARAMETERS AND DIAGRAMS.....</b>	<b>126</b>
24.1	MULTIPLEXED BUS AC CHARACTERISTICS .....	126
24.2	NON-MULTIPLEXED BUS AC CHARACTERISTICS .....	129
24.3	RECEIVE SIDE AC CHARACTERISTICS .....	132
24.4	TRANSMIT AC CHARACTERISTICS.....	136
<b>25.</b>	<b>MECHANICAL DESCRIPTION .....</b>	<b>139</b>

## 1. LIST OF FIGURES

Figure 3-1	SCT BLOCK DIAGRAM.....	9
Figure 16-1	EXTERNAL ANALOG CONNECTIONS .....	87
Figure 16-2	OPTIONAL CRYSTAL CONNECTIONS .....	88
Figure 16-3	TRANSMIT WAVEFORM TEMPLANE.....	89
Figure 16-4	JITTER TOLERANCE.....	91
Figure 16-5	JITTER ATTENUATION.....	91
Figure 16-6	PROTECTED INTERFACE EXAMPLE FOR THE DS21552.....	93
Figure 16-7	PROTECTED INTERFACE EXAMPLE FOR TE DS21352.....	94
Figure 16-8	TYPICAL MONITOR PORT APPLICATION.....	95
Figure 19-1	JTAG FUNCTIONAL BLOCK DIAGRAM.....	100
Figure 19-2	TAP CONTROLLER STATE DIAGRAM.....	103
Figure 20-1	IBO BASIC CONFIGURATION USING 4 SCTS .....	110
Figure 21-1	RECEIVE SIDE D4 TIMING.....	111
Figure 21-2	RECEIVE SIDE ESF TIMING.....	112
Figure 21-3	RECEIVE SIDE BOUNDARY TIMING (with elastic store disabled).....	113
Figure 21-4	RECEIVE SIDE 1.544 MHz BOUNDARY TIMING (with elastic store enabled) .....	113
Figure 21-5	RECEIVE SIDE 2.048 MHz BOUNDARY TIMING (with elastic store enabled) .....	114
Figure 21-6	RECEIVE SIDE INTERLEAVE BUS OPERATION, BYTE MODE .....	115
Figure 21-7	RECEIVE SIDE INTERLEAVE BUS OPERATION, FRAME MODE.....	116
Figure 21-8	TRANSMIT SIDE D4 TIMING.....	117
Figure 21-9	TRANSMIT SIDE ESF TIMING.....	118
Figure 21-10	TRANSMIT SIDE BOUNDARY TIMING (with elastic store disabled).....	119
Figure 21-11	TRANSMIT SIDE 1.544 MHz BOUNDARY TIMING (with elastic store enabled).....	119
Figure 21-12	TRANSMIT SIDE 2.048 MHz BOUNDARY TIMING (with elastic store enabled).....	120
Figure 21-13	TRANSMIT SIDE INTERLEAVE BUS OPERATION, BYTE MODE.....	121
Figure 21-14	TRANSMIT SIDE INTERLEAVE BUS OPERATION, FRAME MODE .....	122
Figure 22-1	RECEIVE DATA FLOW .....	123
Figure 22-2	TRANSMIT DATA FLOW.....	124
Figure 24-1	INTEL BUS READ TIMING (BTS=0 / MUX=1).....	127
Figure 24-2	INTEL BUS WRITE TIMING (BTS=0 / MUX=1) .....	127
Figure 24-3	MOTOROLA BUS TIMING (BTS=1 / MUX=1).....	128
Figure 24-4	INTEL BUS READ TIMING (BTS=0 / MUX=0).....	130
Figure 24-5	INTEL BUS READ TIMING (BTS=0 / MUX=0).....	130
Figure 24-6	MOTOROLA BUS READ TIMING (BTS=1 / MUX=0).....	131
Figure 24-7	MOTOROLA BUS READ TIMING (BTS=1 / MUX=0).....	131
Figure 24-8	RECEIVE SIDE TIMING .....	133
Figure 24-9	RECEIVE SIDE TIMING, ELASTIC STORE ENABLED.....	134
Figure 24-10	RECEIVE LINE INTERFACE TIMING .....	135
Figure 24-11	TRANSMIT SIDE TIMING.....	137
Figure 24-12	TRANSMIT SIDE TIMING, ELASTIC STORE ENABLED .....	138
Figure 24-13	TRANSMIT LINE INTERFACE TIMING.....	138

## 2. LIST OF TABLES

Table 4-1	PIN DESCRIPTION SORTED BY PIN NUMBER.....	11
Table 4-2	PIN DESCRIPTION SORTED BY PIN SYMBOL .....	14
Table 5-1	REGISTER MAP SORTED BY ADDRESS.....	29
Table 6-1	DEVICE ID BIT MAP .....	33
Table 6-2	OUTPUT PIN TEST MODES .....	36
Table 7-1	RECEIVE T1 LEVEL INDICATION .....	47
Table 7-2	ALARM CRITERIA .....	49
Table 8-1	LINE CODE VIOLATION COUNTING ARRANGEMENTS .....	53
Table 8-2	PATH CODE VIOLATION COUNTING ARRANGEMENTS .....	54
Table 8-3	MULTIFRAMES OUT OF SYNC COUNTING ARRANGMENTS .....	55
Table 14-1	ELASTIC STORE DELAY AFTER INITIALIZATION.....	67
Table 14-2	MINIMUM DELAY MODE CONFIGURATION.....	67
Table 15-1	TRANSMIT HDLC CONFIGURATION.....	68
Table 15-2	HDLC/BOC CONTROLLER REGISTERS .....	70
Table 16-1	LINE BUILD OUT SELECT IN LICR .....	86
Table 16-2	TRANSMIT TRANSFORMER SELECTION .....	87
Table 16-3	TRANSFORMER SPECIFICATIONS.....	88
Table 16-4	PULSE TEMPLATE CORNER POINTS.....	90
Table 16-5	RECEIVE MONITOR MODE GAIN.....	95
Table 17-1	TRANSMIT CODE LENGTH.....	97
Table 17-2	RECEIVE CODE LENGTH .....	97
Table 19-1	INSTRUCTION CODES FOR IEEE 1149.1 ARCHITECTURE .....	104
Table 19-2	ID CODE STRUCTURE .....	105
Table 19-3	DEVICE ID CODES .....	105
Table 19-4	BOUNDARY SCAN CONTROL BITS .....	106
Table 20-1	MASTER DEVICE BUS SELECT.....	110

### 3. INTRODUCTION

The DS21352/552 are 3.3V/5V superset versions of the popular DS2152 T1 single-chip transceiver offering the new features listed below. All of the original features of the DS2152 have been retained and software created for the original devices is transferable into the DS21352/552.

#### NEW FEATURES (after the DS2152)

- Interleaving PCM Bus Operation
- Integral HDLC controller with 64-byte buffers Configurable for FDL or DS0 operation
- IEEE 1149.1 JTAG-Boundary Scan Architecture
- 3.3V (DS21352 only) supply

#### FEATURES

- option for non-multiplexed bus operation
- crystal-less jitter attenuation
- 3.3V I/O on all SCTs
- additional hardware signaling capability including:
  - receive signaling reinsertion to a backplane multiframe sync
  - availability of signaling in a separate PCM data stream
  - signaling freezing
  - interrupt generated on change of signaling data
- ability to calculate and check CRC6 according to the Japanese standard
- ability to pass the F-Bit position through the elastic stores in the 2.048 MHz backplane mode
- programmable in-band loop code generator and detector
- per channel loopback and idle code insertion
- RCL, RLOS, RRA, and RAIS alarms now interrupt on change of state
- 8.192 MHz clock output synthesized to RCLK
- HDLC controller can be configured for FDL
- addition of hardware pins to indicate carrier loss & signaling freeze
- line interface function can be completely decoupled from the framer/formatter to allow:
  - interface to optical, HDSL, and other NRZ interfaces
  - be able to “tap” the transmit and receive bipolar data streams for monitoring purposes
  - be able corrupt data and insert framing errors, CRC errors, etc.
- transmit and receive elastic stores now have independent backplane clocks

### 3.1 FUNCTIONAL DESCRIPTION

The analog AMI/B8ZS waveform off of the T1 line is transformer coupled into the RRING and RTIP pins of the DS21352/552. The device recovers clock and data from the analog signal and passes it through the jitter attenuation mux to the receive side framer where the digital serial stream is analyzed to locate the framing/multi-frame pattern. The DS21352/552 contains an active filter that reconstructs the analog received signal for the nonlinear losses that occur in transmission. The device has a usable receive sensitivity of 0 dB to –36 dB, which allows the device to operate on cables up to 6000 feet in length. The receive side framer locates D4 (SLC–96) or ESF multiframe boundaries as well as detects incoming alarms including, carrier loss, loss of synchronization, blue (AIS) and yellow alarms. If needed, the receive side elastic store can be enabled in order to absorb the phase and frequency differences between the recovered T1 data stream and an asynchronous backplane clock which is provided at the RSYCLK input. The clock applied at the RSYCLK input can be either a 2.048 MHz clock or a 1.544 MHz clock. The RSYCLK can be a bursty clock with speeds up to 8.192 MHz.

The transmit side of the DS21352/552 is totally independent from the receive side in both the clock requirements and characteristics. Data off of a backplane can be passed through a transmit side elastic store if necessary. The transmit formatter will provide the necessary frame/multiframe data overhead for T1 transmission. Once the data stream has been prepared for transmission, it is sent via the jitter attenuation mux to the waveshaping and line driver functions. The DS21352/552 will drive the T1 line from the TTIP and TRING pins via a coupling transformer. The line driver can handle both long haul (CSU) and short haul (DSX–1) lines.

**Reader’s Note:** This data sheet assumes a particular nomenclature of the T1 operating environment. In each 125  $\mu$ s frame, there are 24 eight-bit channels plus a framing bit. It is assumed that the framing bit is sent first followed by channel 1. Each channel is made up of eight bits, which are numbered, 1 to 8. Bit number 1 is the MSB and is transmitted first. Bit number 8 is the LSB and is transmitted last. The term “locked” is used to refer to two clock signals that are phase or frequency locked or derived from a common clock (i.e., a 1.544 MHz clock may be locked to a 2.048MHz clock if they share the same 8 kHz component). Throughout this data sheet, the following abbreviations will be used:

B8ZS	Bipolar with 8 Zero Substitution
BOC	Bit Oriented Code
CRC	Cyclical Redundancy Check
D4	Superframe (12 frames per multiframe) Multiframe Structure
ESF	Extended Superframe (24 frames per multiframe) Multiframe Structure
FDL	Facility Data Link
FPS	Framing Pattern Sequence in ESF
Fs	Signaling Framing Pattern in D4
Ft	Terminal Framing Pattern in D4
HDLC	High Level Data Link Control
MF	Multiframe
SLC–96	Subscriber Loop Carrier – 96 Channels (SLC–96 is an AT&T registered trademark)





## 3.2 DOCUMENT REVISION HISTORY

Revision	Notes
12-10-98	Initial Release
12-18-98	Add LIUODO (LIU Open Drain Output) to CCR7.0 Add CDIG (Customer Disconnect Indication Generator) to CCR7.1 Add LIUSI (Line Interface Unit Synchronization Interface) to CCR7.2 Correct IBO register bit functions order Add bit level description to CCR3.6
1-4-99	Delete <b>“The elastic stores can be forced to a known depth via the Elastic Store Reset bit (CCR3.6). Toggling the CCR3.6 bit forces the read and write pointers into opposite frames”</b> from section 12.0
1-18-99	Add receive IBO operation PCM timing diagram
1-18-99	Correct Device ID register bit definitions
1-28-99	Correct TSYSCCLK and RSYSCCLK AC timing and add 4.096 MHz and 8.192 MHz AC timing
2-2-99	Correct definition and label of TUDR bit in TPRM register
2-11-99	Correct format of register definitions in body of data sheet
4-1-99	Add Receive Monitor Mode section
4-15-99	Add section on Protected Interfaces
5-7-99	Correct FMS pin # and description in JTAG section
5-17-99	Correct name of status registers in section 15.3.2
5-19-99	Correct definition of RIR3.4
7-27-99	Correct Receive Monitor Mode section
8-16-99	Remove “Preliminary” notice from data sheet

## 4. PIN DESCRIPTION

**Table 4-1 PIN DESCRIPTION SORTED BY PIN NUMBER**

PIN	SYMBOL	TYPE	DESCRIPTION
1	RCHBLK	O	Receive Channel Block
2	JTMS	I	IEEE 1149.1 Test Mode Select
3	8MCLK	O	8.192 MHz Clock
4	JTCLK	I	IEEE 1149.1 Test Clock Signal
5	JTRST	I	IEEE 1149.1 Test Reset
6	RCL	O	Receive Carrier Loss
7	JTDI	I	IEEE 1149.1 Test Data Input
8	NC	–	No Connect
9	NC	–	No Connect
10	JTDO	O	IEEE 1149.1 Test Data Output
11	BTS	I	Bus Type Select
12	LIUC	I	Line Interface Connect
13	8XCLK	O	Eight Times Clock
14	TEST	I	Test
15	NC	–	No Connect
16	RTIP	I	Receive Analog Tip Input
17	RRING	I	Receive Analog Ring Input
18	RVDD	–	Receive Analog Positive Supply
19	RVSS	–	Receive Analog Signal Ground
20	RVSS	–	Receive Analog Signal Ground
21	MCLK	I	Master Clock Input
22	XTALD	O	Quartz Crystal Driver
23	NC	–	No Connect
24	RVSS	–	Receive Analog Signal Ground
25	INT*	O	Interrupt
26	NC	–	No Connect
27	NC	–	No Connect
28	NC	–	No Connect
29	TTIP	O	Transmit Analog Tip Output
30	TVSS	–	Transmit Analog Signal Ground
31	TVDD	–	Transmit Analog Positive Supply
32	TRING	O	Transmit Analog Ring Output
33	TCHBLK	O	Transmit Channel Block
34	TLCLK	O	Transmit Link Clock
35	TLINK	I	Transmit Link Data
36	CI	I	Carry In
37	TSYNC	I/O	Transmit Sync
38	TPOSI	I	Transmit Positive Data Input
39	TNEGI	I	Transmit Negative Data Input
40	TCLKI	I	Transmit Clock Input
41	TCLKO	O	Transmit Clock Output
42	TNEGO	O	Transmit Negative Data Output
43	TPOSO	O	Transmit Positive Data Output

**Table 4-1 PIN DESCRIPTION SORTED BY PIN NUMBER (cont.)**

PIN	SYMBOL	TYPE	DESCRIPTION
44	DVDD	–	Digital Positive Supply
45	DVSS	–	Digital Signal Ground
46	TCLK	I	Transmit Clock
47	TSER	I	Transmit Serial Data
48	TSIG	I	Transmit Signaling Input
49	TESO	O	Transmit Elastic Store Output

50	TDATA	I	Transmit Data
51	TSYSCLK	I	Transmit System Clock
52	TSSYNC	I	Transmit System Sync
53	TCHCLK	O	Transmit Channel Clock
54	CO	O	Carry Out
55	MUX	I	Bus Operation
56	D0/AD0	I/O	Data Bus Bit0/ Address/Data Bus Bit 0
57	D1/AD1	I/O	Data Bus Bit1/ Address/Data Bus Bit 1
58	D2/AD2	I/O	Data Bus Bit 2/Address/Data Bus 2
59	D3/AD3	I/O	Data Bus Bit 3/Address/Data Bus Bit 3
60	DVSS	-	Digital Signal Ground
61	DVDD	-	Digital Positive Supply
62	D4/AD4	I/O	Data Bus Bit4/Address/Data Bus Bit 4
63	D5/AD5	I/O	Data Bus Bit 5/Address/Data Bus Bit 5
64	D6/AD6	I/O	Data Bus Bit 6/Address/Data Bus Bit 6
65	D7/AD7	I/O	Data Bus Bit 7/Address/Data Bus Bit 7
66	A0	I	Address Bus Bit 0
67	A1	I	Address Bus Bit 1
68	A2	I	Address Bus Bit 2
69	A3	I	Address Bus Bit 3
70	A4	I	Address Bus Bit 4
71	A5	I	Address Bus Bit 5
72	A6	I	Address Bus Bit 6
73	ALE (AS)/A7	I	Address Latch Enable/Address Bus Bit 7
74	RD*(DS*)	I	Read Input(Data Strobe)
75	CS*	I	Chip Select
76	FMS	I	Framer Mode Select
77	WR*(R/W*)	I	Write Input(Read/Write)
78	RLINK	O	Receive Link Data
79	RLCLK	O	Receive Link Clock
80	DVSS	-	Digital Signal Ground
81	DVDD	-	Digital Positive Supply
82	RCLK	O	Receive Clock
83	DVDD	-	Digital Positive Supply
84	DVSS	-	Digital Signal Ground
85	RDATA	O	Receive Data
86	RPOSI	I	Receive Positive Data Input
87	RNEGI	I	Receive Negative Data Input
88	RCLKI	I	Receive Clock Input

**Table 4-1 PIN DESCRIPTION SORTED BY PIN NUMBER (cont.)**

PIN	SYMBOL	TYPE	DESCRIPTION
89	RCLKO	O	Receive Clock Output
90	RNEGO	O	Receive Negative Data Output
91	RPOSO	O	Receive Positive Data Output
92	RCHCLK	O	Receive Channel Clock
93	RSIGF	O	Receive Signaling Freeze Output
94	RSIG	O	Receive Signaling Output
95	RSER	O	Receive Serial Data
96	RMSYNC	O	Receive Multiframe Sync
97	RFSYNC	O	Receive Frame Sync
98	RSYNC	I/O	Receive Sync
99	RLOS/LOTC	O	Receive Loss Of Sync/ Loss Of Transmit Clock
100	RSYSCLK	I	Receive System Clock

**Table 4-1 PIN DESCRIPTION SORTED BY PIN SYMBOL**

PIN	SYMBOL	TYPE	DESCRIPTION
3	8MCLK	O	8.192 MHz Clock
13	8XCLK	O	Eight Times Clock
66	A0	I	Address Bus Bit 0
67	A1	I	Address Bus Bit 1
68	A2	I	Address Bus Bit 2
69	A3	I	Address Bus Bit 3
70	A4	I	Address Bus Bit 4
71	A5	I	Address Bus Bit 5
72	A6	I	Address Bus Bit 6
73	ALE (AS)/A7	I	Address Latch Enable/Address Bus Bit 7
11	BTS	I	Bus Type Select
36	CI	I	Carry In
54	CO	O	Carry Out
75	CS*	I	Chip Select
56	D0/AD0	I/O	Data Bus Bit0/ Address/Data Bus Bit 0
57	D1/AD1	I/O	Data Bus Bit1/ Address/Data Bus Bit 1
58	D2/AD2	I/O	Data Bus Bit 2/Address/Data Bus 2
59	D3/AD3	I/O	Data Bus Bit 3/Address/Data Bus Bit 3
62	D4/AD4	I/O	Data Bus Bit4/Address/Data Bus Bit 4
63	D5/AD5	I/O	Data Bus Bit 5/Address/Data Bus Bit 5
64	D6/AD6	I/O	Data Bus Bit 6/Address/Data Bus Bit 6
65	D7/AD7	I/O	Data Bus Bit 7/Address/Data Bus Bit 7
44	DVDD	–	Digital Positive Supply
81	DVDD	–	Digital Positive Supply
45	DVSS	–	Digital Signal Ground
60	DVSS	–	Digital Signal Ground
80	DVSS	–	Digital Signal Ground
84	DVSS	–	Digital Signal Ground
76	FMS	I	Framer Mode Select
61	DVDD	-	Digital Positive Supply
83	DVDD	–	Digital Positive Supply
25	INT*	O	Interrupt
4	JTCLK	I	IEEE 1149.1 Test Clock Signal
7	JTDI	I	IEEE 1149.1 Test Data Input
10	JTDO	O	IEEE 1149.1 Test Data Output
2	JTMS	I	IEEE 1149.1 Test Mode Select
5	JTRST	I	IEEE 1149.1 Test Reset
12	LIUC	I	Line Interface Connect
21	MCLK	I	Master Clock Input
55	MUX	I	Bus Operation
8	NC	–	No Connect
9	NC	–	No Connect
15	NC	–	No Connect
23	NC	–	No Connect
26	NC	–	No Connect

**Table 4-1 PIN DESCRIPTION SORTED BY PIN SYMBOL (cont.)**

PIN	SYMBOL	TYPE	DESCRIPTION
27	NC	–	No Connect
28	NC	–	No Connect
1	RCHBLK	O	Receive Channel Block
92	RCHCLK	O	Receive Channel Clock
6	RCL	O	Receive Carrier Loss
82	RCLK	O	Receive Clock

88	RCLKI	I	Receive Clock Input
89	RCLKO	O	Receive Clock Output
74	RD*(DS*)	I	Read Input(Data Strobe)
85	RDATA	O	Receive Data
97	RFSYNC	O	Receive Frame Sync
79	RLCLK	O	Receive Link Clock
78	RLINK	O	Receive Link Data
99	RLOS/LOTC	O	Receive Loss Of Sync/ Loss Of Transmit Clock
96	RMSYNC	O	Receive Multiframe Sync
87	RNEGI	I	Receive Negative Data Input
90	RNEGO	O	Receive Negative Data Output
86	RPOSI	I	Receive Positive Data Input
91	RPOSO	O	Receive Positive Data Output
17	RRING	I	Receive Analog Ring Input
95	RSER	O	Receive Serial Data
94	RSIG	O	Receive Signaling Output
93	RSIGF	O	Receive Signaling Freeze Output
98	RSYNC	I/O	Receive Sync
100	RSYSCLK	I	Receive System Clock
16	RTIP	I	Receive Analog Tip Input
18	RVDD	–	Receive Analog Positive Supply
19	RVSS	–	Receive Analog Signal Ground
20	RVSS	–	Receive Analog Signal Ground
24	RVSS	–	Receive Analog Signal Ground
33	TCHBLK	O	Transmit Channel Block
53	TCHCLK	O	Transmit Channel Clock
46	TCLK	I	Transmit Clock
40	TCLKI	I	Transmit Clock Input
41	TCLKO	O	Transmit Clock Output
50	TDATA	I	Transmit Data
49	TESO	O	Transmit Elastic Store Output
14	TEST	I	Test
34	TLCLK	O	Transmit Link Clock
35	TLINK	I	Transmit Link Data
39	TNEGI	I	Transmit Negative Data Input
42	TNEGO	O	Transmit Negative Data Output
38	TPOSI	I	Transmit Positive Data Input
43	TPOSO	O	Transmit Positive Data Output
32	TRING	O	Transmit Analog Ring Output

**Table 4-1 PIN DESCRIPTION SORTED BY PIN SYMBOL (cont.)**

47	TSER	I	Transmit Serial Data
48	TSIG	I	Transmit Signaling Input
52	TSSYNC	I	Transmit System Sync
37	TSYNC	I/O	Transmit Sync
51	TSYSCLK	I	Transmit System Clock
29	TTIP	O	Transmit Analog Tip Output
31	TVDD	–	Transmit Analog Positive Supply
30	TVSS	–	Transmit Analog Signal Ground
77	WR*(R/W*)	I	Write Input(Read/Write)
22	XTALD	O	Quartz Crystal Driver

## 4. PIN FUNCTION DESCRIPTION

### 4.1.1 TRANSMIT SIDE PINS

Signal Name: **TCLK**

Signal Description: **Transmit Clock**

Signal Type: **Input**

A 1.544 MHz primary clock. Used to clock data through the transmit side formatter.

Signal Name: **TSER**

Signal Description: **Transmit Serial Data**

Signal Type: **Input**

Transmit NRZ serial data. Sampled on the falling edge of TCLK when the transmit side elastic store is disabled. Sampled on the falling edge of TSYCLK when the transmit side elastic store is enabled.

Signal Name: **TCHCLK**

Signal Description: **Transmit Channel Clock**

Signal Type: **Output**

A 192 kHz clock which pulses high during the LSB of each channel. Synchronous with TCLK when the transmit side elastic store is disabled. Synchronous with TSYCLK when the transmit side elastic store is enabled. Useful for parallel to serial conversion of channel data.

Signal Name: **TCHBLK**

Signal Description: **Transmit Channel Block**

Signal Type: **Output**

A user programmable output that can be forced high or low during any of the 24 T1 channels. Synchronous with TCLK when the transmit side elastic store is disabled. Synchronous with TSYCLK when the transmit side elastic store is enabled. Useful for blocking clocks to a serial UART or LAPD controller in applications where not all T1 channels are used such as Fractional T1, 384 kbps (H0), 768 kbps or ISDN-PRI. Also useful for locating individual channels in drop-and-insert applications, for external per-channel loopback, and for per-channel conditioning. See section 13 on page 76 for more information.

Signal Name: **TSYSCLK**

Signal Description: **Transmit System Clock**

Signal Type: **Input**

1.544 MHz, 2.048 MHz, 4.096 MHz or 8.192 MHz clock. Only used when the transmit side elastic store function is enabled. Should be tied low in applications that do not use the transmit side elastic store. See section 20 on page 129 for details on 4.096 MHz and 8.192 MHz operation using the Interleave Bus Option.

Signal Name: **TLCLK**

Signal Description: **Transmit Link Clock**

Signal Type: **Output**

4 kHz or 2 kHz (ZBTSI) demand clock for the TLINK input. See Section 15 for details. Transmit Link Data [TLINK].

### 4.1.1 TRANSMIT SIDE PINS (cont.)

Signal Name: **TLINK**  
 Signal Description: **Transmit Link Data**  
 Signal Type: **Input**

If enabled via TCR1.2, this pin will be sampled on the falling edge of TCLK for data insertion into either the FDL stream (ESF) or the Fs-bit position (D4) or the Z-bit position (ZBTSI). See Section 15 for details.

Signal Name: **TSYNC**  
 Signal Description: **Transmit Sync**  
 Signal Type: **Input / Output**

A pulse at this pin will establish either frame or multiframe boundaries for the transmit side. Via TCR2.2, the DS21352/552 can be programmed to output either a frame or multiframe pulse at this pin. If this pin is set to output pulses at frame boundaries, it can also be set via TCR2.4 to output double-wide pulses at signaling frames. See Section 20 for details.

Signal Name: **TSSYNC**  
 Signal Description: **Transmit System Sync**  
 Signal Type: **Input**

Only used when the transmit side elastic store is enabled. A pulse at this pin will establish either frame or multiframe boundaries for the transmit side. Should be tied low in applications that do not use the transmit side elastic store.

Signal Name: **TSIG**  
 Signal Description: **Transmit Signaling Input**  
 Signal Type: **Input**

When enabled, this input will sample signaling bits for insertion into outgoing PCM T1 data stream. Sampled on the falling edge of TCLK when the transmit side elastic store is disabled. Sampled on the falling edge of TSYSCCLK when the transmit side elastic store is enabled.

Signal Name: **TESO**  
 Signal Description: **Transmit Elastic Store Data Output**  
 Signal Type: **Output**

Updated on the rising edge of TCLK with data out of the transmit side elastic store whether the elastic store is enabled or not. This pin is normally tied to TDATA.

Signal Name: **TDATA**  
 Signal Description: **Transmit Data**  
 Signal Type: **Input**

Sampled on the falling edge of TCLK with data to be clocked through the transmit side formatter. This pin is normally tied to TESO.

Signal Name: **TPOSO**  
 Signal Description: **Transmit Positive Data Output**  
 Signal Type: **Output**

Updated on the rising edge of TCLKO with the bipolar data out of the transmit side formatter. Can be programmed to source NRZ data via the Output Data Format (CCR1.6) control bit. This pin is normally tied to TPOSI.



### 4.1.1 TRANSMIT SIDE PINS (cont.)

Signal Name: **TNEGO**

Signal Description: **Transmit Negative Data Output**

Signal Type: **Output**

Updated on the rising edge of TCLKO with the bipolar data out of the transmit side formatter. This pin is normally tied to TNEGI.

Signal Name: **TCLKO**

Signal Description: **Transmit Clock Output**

Signal Type: **Output**

Buffered clock that is used to clock data through the transmit side formatter (i.e., either TCLK or RCLKI). This pin is normally tied to TCLKI.

Signal Name: **TPOSI**

Signal Description: **Transmit Positive Data Input**

Signal Type: **Input**

Sampled on the falling edge of TCLKI for data to be transmitted out onto the T1 line. Can be internally connected to TPOSO by tying the LIUC pin high.

Signal Name: **TNEGI**

Signal Description: **Transmit Negative Data Input**

Signal Type: **Input**

Sampled on the falling edge of TCLKI for data to be transmitted out onto the T1 line. Can be internally connected to TNEGO by tying the LIUC pin high.

Signal Name: **TCLKI**

Signal Description: **Transmit Clock Input**

Signal Type: **Input**

Line interface transmit clock. Can be internally connected to TCLKO by tying the LIUC pin high.

## 4.1.2 RECEIVE SIDE PINS

Signal Name: **RLINK**  
 Signal Description: **Receive Link Data**  
 Signal Type: **Output**

Updated with either FDL data (ESF) or Fs bits (D4) or Z bits (ZBTSI) one RCLK before the start of a frame. See Section 20 for details.

Signal Name: **RLCLK**  
 Signal Description: **Receive Link Clock**  
 Signal Type: **Output**

A 4 kHz or 2 kHz (ZBTSI) clock for the RLINK output.

Signal Name: **RCLK**  
 Signal Description: **Receive Clock**  
 Signal Type: **Output**

1.544 MHz clock that is used to clock data through the receive side framer.

Signal Name: **RCHCLK**  
 Signal Description: **Receive Channel Clock**  
 Signal Type: **Output**

A 192 kHz clock which pulses high during the LSB of each channel. Synchronous with RCLK when the receive side elastic store is disabled. Synchronous with RSYCLK when the receive side elastic store is enabled. Useful for parallel to serial conversion of channel data.

Signal Name: **RCHBLK**  
 Signal Description: **Receive Channel Block**  
 Signal Type: **Output**

A user programmable output that can be forced high or low during any of the 24 T1 channels. Synchronous with RCLK when the receive side elastic store is disabled. Synchronous with RSYCLK when the receive side elastic store is enabled. Useful for blocking clocks to a serial UART or LAPD controller in applications where not all T1 channels are used such as Fractional T1, 384K bps service, 768K bps, or ISDN-PRI. Also useful for locating individual channels in drop-and-insert applications, for external per-channel loopback, and for per-channel conditioning. See Section 13 page 76 for details.

Signal Name: **RSER**  
 Signal Description: **Receive Serial Data**  
 Signal Type: **Output**

Received NRZ serial data. Updated on rising edges of RCLK when the receive side elastic store is disabled. Updated on the rising edges of RSYCLK when the receive side elastic store is enabled.

Signal Name: **RSYNC**  
 Signal Description: **Receive Sync**  
 Signal Type: **Input/Output**

An extracted pulse, one RCLK wide, is output at this pin which identifies either frame ( $RCR2.4 = 0$ ) or multiframe ( $RCR2.4 = 1$ ) boundaries. If set to output frame boundaries then via RCR2.5, RSYNC can also be set to output double-wide pulses on signaling frames. If the receive side elastic store is enabled via CCR1.2, then this pin can be enabled to be an input via RCR2.3 at which a frame or multiframe boundary pulse is applied. See Section 21 for details.

## 4.1.2 RECEIVE SIDE PINS (cont.)

Signal Name: **RFSYNC**

Signal Description: **Receive Frame Sync**

Signal Type: **Output**

An extracted 8 kHz pulse, one RCLK wide, is output at this pin which identifies frame boundaries.

Signal Name: **RMSYNC**

Signal Description: **Receive Multiframe Sync**

Signal Type: **Output**

Only used when the receive side elastic store is enabled. An extracted pulse, one RSYCLK wide, is output at this pin which identifies multiframe boundaries. If the receive side elastic store is disabled, then this output will output multiframe boundaries associated with RCLK.

Signal Name: **RDATA**

Signal Description: **Receive Data**

Signal Type: **Output**

Updated on the rising edge of RCLK with the data out of the receive side framer.

Signal Name: **RSYSCLK**

Signal Description: **Receive System Clock**

Signal Type: **Input**

1.544 MHz, 2.048 MHz, 4.096 MHz or 8.192 MHz clock. Only used when the receive side elastic store function is enabled. Should be tied low in applications that do not use the receive side elastic store. See section 20 on page 129 for details on 4.096 MHz and 8.192 MHz operation using the Interleave Bus Option.

Signal Name: **RSIG**

Signal Description: **Receive Signaling Output**

Signal Type: **Output**

Outputs signaling bits in a PCM format. Updated on rising edges of RCLK when the receive side elastic store is disabled. Updated on the rising edges of RSYCLK when the receive side elastic store is enabled.

Signal Name: **RLOS/LOTC**

Signal Description: **Receive Loss of Sync / Loss of Transmit Clock**

Signal Type: **Output**

A dual function output that is controlled by the CCR3.5 control bit. This pin can be programmed to either toggle high when the synchronizer is searching for the frame and multiframe or to toggle high if the TCLK pin has not been toggled for 5  $\mu$ sec.

Signal Name: **RCL**

Signal Description: **Receive Carrier Loss**

Signal Type: **Output**

Set high when the line interface detects a carrier loss.

Signal Name: **RSIGF**

Signal Description: **Receive Signaling Freeze**

Signal Type: **Output**

Set high when the signaling data is frozen via either automatic or manual intervention. Used to alert downstream equipment of the condition.

## 4.1.2 RECEIVE SIDE PINS (cont.)

Signal Name: **8MCLK**

Signal Description: **8 MHz Clock**

Signal Type: **Output**

An 8.192MHz clock output that is referenced to the clock that is output at the RCLK pin.

Signal Name: **RPOSO**

Signal Description: **Receive Positive Data Input**

Signal Type: **Output**

---

Updated on the rising edge of RCLKO with bipolar data out of the line interface. This pin is normally tied to RPOSI.

Signal Name: **RNEGO**  
Signal Description: **Receive Negative Data Input**  
Signal Type: **Output**

Updated on the rising edge of RCLKO with the bipolar data out of the line interface. This pin is normally tied to RPOSI.

Signal Name: **RCLKO**  
Signal Description: **Receive Clock Output**  
Signal Type: **Output**

Buffered recovered clock from the T1 line. This pin is normally tied to RCLKI.

Signal Name: **RPOSI**  
Signal Description: **Receive Positive Data Input**  
Signal Type: **Input**

Sampled on the falling edge of RCLKI for data to be clocked through the receive side framer. RPOSI and RNEGI can be tied together for a NRZ interface. Can be internally connected to RPOSO by tying the LIUC pin high.

Signal Name: **RNEGI**  
Signal Description: **Receive Negative Data Input**  
Signal Type: **Input**

Sampled on the falling edge of RCLKI for data to be clocked through the receive side framer. RPOSI and RNEGI can be tied together for a NRZ interface. Can be internally connected to RNEGO by tying the LIUC pin high.

Signal Name: **RCLKI**  
Signal Description: **Receive Clock Input**  
Signal Type: **Input**

Clock used to clock data through the receive side framer. This pin is normally tied to RCLKO. Can be internally connected to RCLKO by tying the LIUC pin high.

### 4.1.3 PARALLEL CONTROL PORT PINS

Signal Name: **INT\***

Signal Description: **Interrupt**

Signal Type: **Output**

Flags host controller during conditions and change of conditions defined in the Status Registers 1 and 2 and the HDLC Status Register. Active low, open drain output

Signal Name: **FMS**

Signal Description: **Framer Mode Select**

Signal Type: **Input**

Selects the DS2152 mode when high or the DS21352/552 mode when low. If high, the JTRST is internally pulled low. If low, JTRST has normal JTAG functionality. This pin has a 10k pull up resistor.

Signal Name: **TEST**

Signal Description: **3-State Control**

Signal Type: **Input**

Set high to 3-state all output and I/O pins (including the parallel control port) when FMS = 1 or when FMS = 0 and JTRST\* is tied low. Set low for normal operation. Ignored when FMS = 0 and JTRST\* = 1. Useful for board level testing.

Signal Name: **MUX**

Signal Description: **Bus Operation**

Signal Type: **Input**

Set low to select non-multiplexed bus operation. Set high to select multiplexed bus operation.

Signal Name: **AD0 TO AD7**

Signal Description: **Data Bus [D0 to D7] or Address/Data Bus**

Signal Type: **Input**

In non-multiplexed bus operation (MUX = 0), serves as the data bus. In multiplexed bus operation (MUX = 1), serves as a 8-bit multiplexed address / data bus.

Signal Name: **A0 TO A6**

Signal Description: **Address Bus**

Signal Type: **Input**

In non-multiplexed bus operation (MUX = 0), serves as the address bus. In multiplexed bus operation (MUX = 1), these pins are not used and should be tied low.

Signal Name: **BTS**

Signal Description: **Bus Type Select**

Signal Type: **Input**

Strap high to select Motorola bus timing; strap low to select Intel bus timing. This pin controls the function of the RD\*(DS\*), ALE(AS), and WR\*(R/W\*) pins. If BTS = 1, then these pins assume the function listed in parenthesis ().

Signal Name: **RD\*(DS\*)**

Signal Description: **Read Input - Data Strobe**

Signal Type: **Input**

RD\* and DS\* are active low signals. DS active HIGH when MUX = 0. See bus timing diagrams.

### 4.1.3 PARALLEL CONTROL PORT PINS (cont.)

Signal Name: **CS\***  
Signal Description: **Chip Select**  
Signal Type: **Input**

Must be low to read or write to the device. CS\* is an active low signal.

Signal Name: **ALE(AS)/A7**  
Signal Description: **Address Latch Enable(Address Strobe) or A7**  
Signal Type: **Input**

In non-multiplexed bus operation (MUX = 0), serves as the upper address bit. In multiplexed bus operation (MUX = 1), serves to de-multiplex the bus on a positive-going edge.

Signal Name: **WR\*(R/W\*)**  
Signal Description: **Write Input(Read/Write)**  
Signal Type: **Input**

WR\* is an active low signal.

#### 4.1.4 JTAG TEST ACCESS PORT PINS

Signal Name: **JTRST**  
 Signal Description: **IEEE 1149.1 Test Reset**  
 Signal Type: **Input**

If FMS = 1: JTAG functionality is not available and JTRST is held LOW internally.

If FMS = 0: JTAG functionality is available and JTRST is pulled up internally by a 10kΩ resistor.

If FMS = 0 and boundary scan is not used, this pin should be held low. This signal is used to asynchronously reset the test access port controller. The device operates as a T1/E1 transceiver if JTRST is pulled low.

Signal Name: **JTMS**  
 Signal Description: **IEEE 1149.1 Test Mode Select**  
 Signal Type: **Input**

This pin is sampled on the rising edge of JTCLK and is used to place the test access port into the various defined IEEE 1149.1 states. This pin has a 10k pull up resistor.

Signal Name: **JTCLK**  
 Signal Description: **IEEE 1149.1 Test Clock Signal**  
 Signal Type: **Input**

This signal is used to shift data into JTDI on the rising edge and out of JTDO on the falling edge.

Signal Name: **JTDI**  
 Signal Description: **IEEE 1149.1 Test Data Input**  
 Signal Type: **Input**

Test instructions and data are clocked into this pin on the rising edge of JTCLK. This pin has a 10k pull up resistor.

Signal Name: **JTDO**  
 Signal Description: **IEEE 1149.1 Test Data Output**  
 Signal Type: **Output**

Test instructions and data are clocked out of this pin on the falling edge of JTCLK. If not used, this pin should be left unconnected.

#### 4.1.5 INTERLEAVE BUS OPERATION PINS

Signal Name: **CI**  
 Signal Description: **Carry In**  
 Signal Type: **Input**

A rising edge on this pin causes RSER and RSIG to come out of high Z state and TSER and TSIG to start sampling on the next rising edge of RSYCLK/TSYCLK beginning an I/O sequence of 8 or 256 bits of data. This pin has a 10k pull up resistor.

Signal Name: **CO**  
 Signal Description: **Carry Out**  
 Signal Type: **Output**

An output that is set high when the last bit of the 8 or 256 IBO output sequence has occurred on RSER and RSIG.

## 4.1.6 LINE INTERFACE PINS

Signal Name: **MCLK**  
 Signal Description: **Master Clock Input**  
 Signal Type: **Input**

A 1.544 MHz (50 ppm) clock source with TTL levels is applied at this pin. This clock is used internally for both clock/data recovery and for jitter attenuation. A quartz crystal of 1.544 MHz may be applied across MCLK and XTALD instead of the TTL level clock source.

Signal Name: **XTALD**  
 Signal Description: **Quartz Crystal Driver**  
 Signal Type: **Output**

A quartz crystal of 1.544 MHz may be applied across MCLK and XTALD instead of a TTL level clock source at MCLK. Leave open circuited if a TTL clock source is applied at MCLK.

Signal Name: **8XCLK**  
 Signal Description: **Eight Times Clock**  
 Signal Type: **Output**

A 12.352 MHz clock that is locked to the 1.544 MHz clock provided from the clock/data recovery block (if the jitter attenuator is enabled on the receive side) or from the TCLKI pin (if the jitter attenuator is enabled on the transmit side). Can be internally disabled by writing a 08h to TEST2.3 if not needed.

Signal Name: **LIUC**  
 Signal Description: **Line Interface Connect**  
 Signal Type: **Input**

Tie low to separate the line interface circuitry from the framer/formatter circuitry and activate the TPOSI/TNEGI/TCLKI/RPOSI/RNEGI/ RCLKI pins. Tie high to connect the line interface circuitry to the framer/formatter circuitry and deactivate the TPOSI/TNEGI/TCLKI/RPOSI/RNEGI/RCLKI pins. When LIUC is tied high, the TPOSI/TNEGI/TCLKI/ RPOSI/RNEGI/RCLKI pins should be tied low.

Signal Name: **RTIP & RRING**  
 Signal Description: **Receive Tip and Ring**  
 Signal Type: **Input**

Analog inputs for clock recovery circuitry. These pins connect via a 1:1 transformer to the T1 line. See Section 16 for details.

Signal Name: **TTIP & TRING**  
 Signal Description: **Transmit Tip and Ring**  
 Signal Type: **Output**

Analog line driver outputs. These pins connect via a transformer to the T1 line. See Section 16 for details.



## 4.1.7 SUPPLY PINS

**Signal Name:** DVDD  
**Signal Description:** Digital Positive Supply  
**Signal Type:** Supply  
5.0 volts +/-5% (DS21552) or 3.3 volts +/-5% (DS21352). Should be tied to the RVDD and TVDD pins.

**Signal Name:** RVDD  
**Signal Description:** Receive Analog Positive Supply  
**Signal Type:** Supply  
5.0 volts +/-5% (DS21552) or 3.3 volts +/-5% (DS21352). Should be tied to the DVDD and TVDD pins.

**Signal Name:** TVDD  
**Signal Description:** Transmit Analog Positive Supply  
**Signal Type:** Supply  
5.0 volts +/-5% (DS21552) or 3.3 volts +/-5% (DS21352). Should be tied to the RVDD and DVDD pins.

**Signal Name:** DVSS  
**Signal Description:** Digital Signal Ground  
**Signal Type:** Supply  
Should be tied to the RVSS and TVSS pins.

**Signal Name:** RVSS  
**Signal Description:** Receive Analog Signal Ground  
**Signal Type:** Supply  
0.0 volts. Should be tied to DVSS and TVSS.

**Signal Name:** TVSS  
**Signal Description:** Transmit Analog Signal Ground  
**Signal Type:** Supply  
0.0 volts. Should be tied to DVSS and RVSS.

## 5. PARALLEL PORT

The SCT is controlled via either a non-multiplexed (MUX = 0) or a multiplexed (MUX = 1) bus by an external microcontroller or microprocessor. The SCT can operate with either Intel or Motorola bus timing configurations. If the BTS pin is tied low, Intel timing will be selected; if tied high, Motorola timing will be selected. All Motorola bus signals are listed in parenthesis (). See the timing diagrams in the A.C. Electrical Characteristics in Section 24 for more details.

### 5.1 REGISTER MAP

**Table 5-1 REGISTER MAP SORTED BY ADDRESS**

ADDRESS	R/W	REGISTER NAME	REGISTER ABBREVIATION
00	R/W	HDLC Control	HCR
01	R/W	HDLC Status	HSR
02	R/W	HDLC Interrupt Mask	HIMR
03	R/W	Receive HDLC Information	RHIR
04	R/W	Receive Bit Oriented Code	RBOC
05	R	Receive HDLC FIFO	RHFR
06	R/W	Transmit HDLC Information	THIR
07	R/W	Transmit Bit Oriented Code	TBOC
08	W	Transmit HDLC FIFO	THFR
09	R/W	Test 2 <b>SEE NOTE 1</b>	TEST2 (set to 00h)
0A	R/W	Common Control 7	CCR7
0B	–	not present	–
0C	–	not present	–
0D	–	not present	–
0E	–	not present	–
0F	R	Device ID	IDR
10	R/W	Receive Information 3	RIR3
11	R/W	Common Control 4	CCR4
12	R/W	In-Band Code Control	IBCC
13	R/W	Transmit Code Definition	TCD
14	R/W	Receive Up Code Definition	RUPCD
15	R/W	Receive Down Code Definition	RDNCD
16	R/W	Transmit Channel Control 1	TCC1
17	R/W	Transmit Channel Control 2	TCC2
18	R/W	Transmit Channel Control 3	TCC3
19	R/W	Common Control 5	CCR5
1A	R	Transmit DS0 Monitor	TDS0M
1B	R/W	Receive Channel Control 1	RCC1
1C	R/W	Receive Channel Control 2	RCC2
1D	R/W	Receive Channel Control 3	RCC3
1E	R/W	Common Control 6	CCR6
1F	R	Receive DS0 Monitor	RDS0M
20	R/W	Status 1	SR1

**Table 5-1 REGISTER MAP SORTED BY ADDRESS (Cont.)**

ADDRESS	R/W	REGISTER NAME	REGISTER ABBREVIATION
21	R/W	Status 2	SR2
22	R/W	Receive Information 1	RIR1
23	R	Line Code Violation Count 1	LCVCR1
24	R	Line Code Violation Count 2	LCVCR2
25	R	Path Code Violation Count 1 <b>SEE NOTE 3</b>	PCVCR1
26	R	Path Code violation Count 2	PCVCR2

ADDRESS	R/W	REGISTER NAME	REGISTER ABBREVIATION
27	R	Multiframe Out of Sync Count 2	MOSCR2
28	R	Receive FDL Register	RFDL
29	R/W	Receive FDL Match 1	RMTCH1
2A	R/W	Receive FDL Match 2	RMTCH2
2B	R/W	Receive Control 1	RCR1
2C	R/W	Receive Control 2	RCR2
2D	R/W	Receive Mark 1	RMR1
2E	R/W	Receive Mark 2	RMR2
2F	R/W	Receive Mark 3	RMR3
30	R/W	Common Control 3	CCR3
31	R/W	Receive Information 2	RIR2
32	R/W	Transmit Channel Blocking 1	TCBR1
33	R/W	Transmit Channel blocking 2	TCBR2
34	R/W	Transmit Channel Blocking 3	TCBR3
35	R/W	Transmit Control 1	TCR1
36	R/W	Transmit Control 2	TCR2
37	R/W	Common Control 1	CCR1
38	R/W	Common Control 2	CCR2
39	R/W	Transmit Transparency 1	TTR1
3A	R/W	Transmit Transparency 2	TTR2
3B	R/W	Transmit Transparency 3	TTR3
3C	R/W	Transmit Idle 1	TIR1
3D	R/W	Transmit Idle 2	TIR2
3E	R/W	Transmit Idle 3	TIR3
3F	R/W	Transmit Idle Definition	TIDR
40	R/W	Transmit Channel 9	TC9
41	R/W	Transmit Channel 10	TC10
42	R/W	Transmit Channel 11	TC11
43	R/W	Transmit Channel 12	TC12
44	R/W	Transmit Channel 13	TC13
45	R/W	Transmit Channel 14	TC14
46	R/W	Transmit Channel 15	TC15
47	R/W	Transmit Channel 16	TC16
48	R/W	Transmit Channel 17	TC17
49	R/W	Transmit Channel 18	TC18
4A	R/W	Transmit Channel 19	TC19
4B	R/W	Transmit Channel 20	TC20
4C	R/W	Transmit Channel 21	TC21

**Table 5-1 REGISTER MAP SORTED BY ADDRESS (Cont.)**

ADDRESS	R/W	REGISTER NAME	REGISTER ABBREVIATION
4D	R/W	Transmit Channel 22	TC22
4E	R/W	Transmit Channel 23	TC23
4F	R/W	Transmit Channel 24	TC24
50	R/W	Transmit Channel 1	TC1
51	R/W	Transmit Channel 2	TC2
52	R/W	Transmit Channel 3	TC3
53	R/W	Transmit Channel 4	TC4
54	R/W	Transmit Channel 5	TC5
55	R/W	Transmit Channel 6	TC6
56	R/W	Transmit Channel 7	TC7
57	R/W	Transmit Channel 8	TC8
58	R/W	Receive Channel 17	RC17
59	R/W	Receive Channel 18	RC18

5A	R/W	Receive Channel 19	RC19
5B	R/W	Receive Channel 20	RC20
5C	R/W	Receive Channel 21	RC21
5D	R/W	Receive Channel 22	RC22
5E	R/W	Receive Channel 23	RC23
5F	R/W	Receive Channel 24	RC24
60	R	Receive Signaling 1	RS1
61	R	Receive Signaling 2	RS2
62	R	Receive Signaling 3	RS3
63	R	Receive Signaling 4	RS4
64	R	Receive Signaling 5	RS5
65	R	Receive Signaling 6	RS6
66	R	Receive Signaling 7	RS7
67	R	Receive Signaling 8	RS8
68	R	Receive Signaling 9	RS9
69	R	Receive Signaling 10	RS10
6A	R	Receive Signaling 11	RS11
6B	R	Receive Signaling 12	RS12
6C	R/W	Receive Channel Blocking 1	RCBR1
6D	R/W	Receive Channel Blocking 2	RCBR2
6E	R/W	Receive Channel Blocking 3	RCBR3
6F	R/W	Interrupt Mask 2	IMR2
70	R/W	Transmit Signaling 1	TS1
71	R/W	Transmit Signaling 2	TS2
72	R/W	Transmit Signaling 3	TS3
73	R/W	Transmit Signaling 4	TS4
74	R/W	Transmit Signaling 5	TS5
75	R/W	Transmit Signaling 6	TS6
76	R/W	Transmit Signaling 7	TS7
77	R/W	Transmit Signaling 8	TS8
78	R/W	Transmit Signaling 9	TS9

**Table 5-1 REGISTER MAP SORTED BY ADDRESS (Cont.)**

ADDRESS	R/W	REGISTER NAME	REGISTER ABBREVIATION
79	R/W	Transmit Signaling 10	TS10
7A	R/W	Transmit Signaling 11	TS11
7B	R/W	Transmit Signaling 12	TS12
7C	R/W	Line Interface Control	LICR
7D	R/W	Test 1 <b>SEE NOTE 1</b>	TEST1 (set to 00h)
7E	R/W	Transmit FDL Register	TFDL
7F	R/W	Interrupt Mask Register 1	IMR1
80	R/W	Receive Channel 1	RC1
81	R/W	Receive Channel 2	RC2
82	R/W	Receive Channel 3	RC3
83	R/W	Receive Channel 4	RC4
84	R/W	Receive Channel 5	RC5
85	R/W	Receive Channel 6	RC6
86	R/W	Receive Channel 7	RC7
87	R/W	Receive Channel 8	RC8
88	R/W	Receive Channel 9	RC9
89	R/W	Receive Channel 10	RC10
8A	R/W	Receive Channel 11	RC11
8B	R/W	Receive Channel 12	RC12
8C	R/W	Receive Channel 13	RC13
8D	R/W	Receive Channel 14	RC14
8E	R/W	Receive Channel 15	RC15

8F	R/W	Receive Channel 16	RC16
90	R/W	Receive HDLC DS0 Control Register 1	RDC1
91	R/W	Receive HDLC DS0 Control Register 2	RDC2
92	R/W	Transmit HDLC DS0 Control Register 1	TDC1
93	R/W	Transmit HDLC DS0 Control Register 2	TDC2
94	R/W	Interleave Bus Operation Register	IBO
95	R/W	Test 3 <b>SEE NOTE 1</b>	TEST3 (set to 00h)
96	R/W	Test 4 <b>SEE NOTE 1</b>	TEST4 (set to 00h)
97	-	not present	-
98	-	not present	-
99	-	not present	-
9A	-	not present	-
9B	-	not present	-
9C	-	not present	-
9D	-	not present	-
9E	-	not present	-
9F	-	not present	-

## NOTES:

1. TEST1, TEST2, TEST3 and TEST4 registers are used by the factory; these registers must be cleared (set to 00h) on power-up initialization to insure proper operation.
2. Register banks Axh, Bxh, Cxh, Dxh, Exh, and Fxh are not accessible.
3. Upper nibble of the PCVCR1 register is used for MOSCR1

## 6. CONTROL, ID, AND TEST REGISTERS

The operation of the DS21352/552 is configured via a set of eleven control registers. Typically, the control registers are only accessed when the system is first powered up. Once the DS21352/552 has been initialized, the control registers will only need to be accessed when there is a change in the system configuration. There are two Receive Control Registers (RCR1 and RCR2), two Transmit Control Registers (TCR1 and TCR2), and seven Common Control Registers (CCR1 to CCR7). Each of the eleven registers are described in this section.

### 6.1 POWER-UP SEQUENCE

On power-up, after the supplies are stable the DS21352/552 should be configured for operation by writing to all of the internal registers (this includes setting the Test Registers to 00h) since the contents of the internal registers cannot be predicted on power-up. The LIRST (CCR7.7) should be toggled from zero to one to reset the line interface circuitry (it will take the DS21352/552 about 40ms to recover from the LIRST bit being toggled). Finally, after the TSYCLK and RSYCLK inputs are stable, the ESR bit should be toggled from a zero to a one (this step can be skipped if the elastic stores are disabled).

### 6.2 DEVICE ID

There is a device IDentification Register (IDR) at address 0Fh. The MSB of this read-only register is fixed to a zero indicating that a T1 device is present. The next 3 MSBs are used to indicate which T1 device is present; DS2152, DS21352, or DS21552. The E1 pin-for-pin compatible SCTs will have a logic one in the MSB position with the following 3 MSBs indicating which E1 SCT is present; DS2154, DS21354, or DS21554. Table 6-1 represents the possible variations of these bits and the associated SCT.

## IDR: DEVICE IDENTIFICATION REGISTER (Address=0F Hex)

(MSB)							(LSB)
T1E1	Bit 6	Bit 5	Bit 4	ID3	ID2	ID1	ID0

SYMBOL	POSITION	NAME AND DESCRIPTION
T1E1	IDR.7	T1 or E1 Chip Determination Bit.

---

		0=T1 chip 1=E1 chip
Bit 6	IDR.6	<b>Bit 6.</b>
Bit 5	IDR.5	<b>Bit 5.</b>
Bit 4	IDR.4	<b>Bit 4.</b>
ID3	IDR.3	<b>Chip Revision Bit 3.</b> MSB of a decimal code that represents the chip revision.
ID2	IDR.1	<b>Chip Revision Bit 2.</b>
ID1	IDR.2	<b>Chip Revision Bit 1.</b>

**Table 6-1 DEVICE ID BIT MAP**

SCT	T1/E1	Bit 6	Bit 5	Bit 4
DS2152	0	0	0	0
DS21352	0	0	0	1
DS21552	0	0	1	0
DS2154	1	0	0	0
DS21354	1	0	0	1
DS21554	1	0	1	0

The lower four bits of the IDR are used to display the die revision of the chip.

## RCR1: RECEIVE CONTROL REGISTER 1 (Address=2B Hex)

(MSB)						(LSB)	
LCVCRF	ARC	OOF1	OOF2	SYNCC	SYNCT	SYNCE	RESYNC

SYMBOL	POSITION	NAME AND DESCRIPTION
LCVCRF	RCR1.7	<b>Line Code Violation Count Register Function Select.</b> 0 = do not count excessive zeros 1 = count excessive zeros
ARC	RCR1.6	<b>Auto Resync Criteria.</b> 0 = Resync on OOF or RCL event 1 = Resync on OOF only
OOF1	RCR1.5	<b>Out Of Frame Select 1.</b> 0 = 2/4 frame bits in error 1 = 2/5 frame bits in error
OOF2	RCR1.4	<b>Out Of Frame Select 2.</b> 0 = follow RCR1.5 1 = 2/6 frame bits in error
SYNCC	RCR1.3	<b>Sync Criteria.</b> In D4 Framing Mode. 0 = search for Ft pattern, then search for Fs pattern 1 = cross couple Ft and Fs pattern In ESF Framing Mode. 0 = search for FPS pattern only 1 = search for FPS and verify with CRC6
SYNCT	RCR1.2	<b>Sync Time.</b> 0 = qualify 10 bits 1 = qualify 24 bits
SYNCE	RCR1.1	<b>Sync Enable.</b> 0 = auto resync enabled 1 = auto resync disabled
RESYNC	RCR1.0	<b>Resync.</b> When toggled from low to high, a resynchronization of the receive side framer is initiated. Must be cleared and set again for a subsequent resync.

**RCR2: RECEIVE CONTROL REGISTER 2 (Address=2C Hex)**

(MSB)							(LSB)
RCS	RZBTSI	RSDW	RSM	RSIO	RD4YM	FSBE	MOSCRF

SYMBOL	POSITION	NAME AND DESCRIPTION
RCS	RCR2.7	<b>Receive Code Select.</b> 0 = idle code (7F Hex) 1 = digital milliwatt code (1E/0B/0B/1E/9E/8B/8B/9E Hex)
RZBTSI	RCR2.6	<b>Receive Side ZBTSI Support Enable.</b> Allows ZBTSI information to be output on RLINK pin. 0 = ZBTSI disabled 1 = ZBTSI enabled
RSDW	RCR2.5	<b>RSYNC Double-Wide.</b> (note: this bit must be set to zero when RCR2.4 = 1 or when RCR2.3 = 1) 0 = do not pulse double wide in signaling frames 1 = do pulse double wide in signaling frames
RSM	RCR2.4	<b>RSYNC Mode Select.</b> Selects frame or multiframe pulse when RSYNC pin is in output mode. In input mode (elastic store must be enabled) multiframe mode is only useful when receive signaling re-insertion is enabled. See the timing in Section 21. 0 = frame mode 1 = multiframe mode
RSIO	RCR2.3	<b>RSYNC I/O Select.</b> (note: this bit must be set to zero when CCR1.2 = 0) 0 = RSYNC is an output 1 = RSYNC is an input (only valid if elastic store enabled)
RD4YM	RCR2.2	<b>Receive Side D4 Yellow Alarm Select.</b> 0 = zeros in bit 2 of all channels 1 = a one in the S-bit position of frame 12
FSBE	RCR2.1	<b>PCVCR Fs-Bit Error Report Enable.</b> 0 = do not report bit errors in Fs-bit position; only Ft bit position 1 = report bit errors in Fs-bit position as well as Ft bit position
MOSCRF	RCR2.0	<b>Multiframe Out of Sync Count Register Function Select.</b> 0 = count errors in the framing bit position 1 = count the number of multiframe out of sync



**TCR1: TRANSMIT CONTROL REGISTER 1 (Address=35 Hex)**

(MSB)						(LSB)	
LOTCCM	TFPT	TCPT	TSSE	GB7S	TFDLS	TBL	TYEL

SYMBOL	POSITION	NAME AND DESCRIPTION
LOTCCM	TCR1.7	<b>Loss Of Transmit Clock Mux Control.</b> Determines whether the transmit side formatter should switch to RCLK if the TCLK input should fail to transition. 0 = do not switch to RCLK if TCLK stops 1 = switch to RCLK if TCLK stops
TFPT	TCR1.6	<b>Transmit F–Bit Pass Through.</b> (see note below) 0 = F bits sourced internally 1 = F bits sampled at TSER
TCPT	TCR1.5	<b>Transmit CRC Pass Through.</b> (see note below) 0 = source CRC6 bits internally 1 = CRC6 bits sampled at TSER during F–bit time
TSSE	TCR1.4	<b>Transmit Software Signaling Enable.</b> (see note below) 0 = no signaling is inserted in any channel 1 = signaling is inserted in all channels from the TS1-TS12 registers (the TTR registers can be used to block insertion on a channel by channel basis)
GB7S	TCR1.3	<b>Global Bit 7 Stuffing.</b> (see note below) 0 = allow the TTR registers to determine which channels containing all zeros are to be Bit 7 stuffed 1 = force Bit 7 stuffing in all zero byte channels regardless of how the TTR registers are programmed
TFDLS	TCR1.2	<b>TFDL Register Select.</b> (see note below) 0 = source FDL or Fs bits from the internal TFDL register (legacy FDL support mode) 1 = source FDL or Fs bits from the internal HDLC/BOC controller or the TLINK pin
TBL	TCR1.1	<b>Transmit Blue Alarm.</b> (see note below) 0 = transmit data normally 1 = transmit an unframed all one's code at TPOSO and TNEGO
TYEL	TCR1.0	<b>Transmit Yellow Alarm.</b> (see note below) 0 = do not transmit yellow alarm 1 = transmit yellow alarm

NOTE: For a description of how the bits in TCR1 affect the transmit side formatter, see Figure 22-2

**TCR2: TRANSMIT CONTROL REGISTER 2 (Address=36 Hex)**

(MSB)						(LSB)	
TEST1	TEST0	TZBTSI	TSDW	TSM	TSIO	TD4YM	TB7ZS

SYMBOL	POSITION	NAME AND DESCRIPTION
TEST1	TCR2.7	<b>Test Mode Bit 1 for Output Pins.</b> See Table 6-2..
TEST0	TCR2.6	<b>Test Mode Bit 0 for Output Pins.</b> See Table 6-2.
TZBTSI	TCR2.5	<b>Transmit Side ZBTSI Support Enable.</b> Allows ZBTSI information to be input on TLINK pin. 0 = ZBTSI disabled 1 = ZBTSI enabled
TSDW	TCR2.4	<b>TSYNC Double-Wide.</b> (note: this bit must be set to zero when TCR2.3=1 or when TCR2.2=0) 0 = do not pulse double-wide in signaling frames 1 = do pulse double-wide in signaling frames
TSM	TCR2.3	<b>TSYNC Mode Select.</b> Selects frame or multiframe mode for the TSYNC pin. See the timing in Section 21 0 = frame mode 1 = multiframe mode
TSIO	TCR2.2	<b>TSYNC I/O Select.</b> 0 = TSYNC is an input 1 = TSYNC is an output
TD4YM	TCR2.1	<b>Transmit Side D4 Yellow Alarm Select.</b> 0 = zeros in bit 2 of all channels 1 = a one in the S-bit position of frame 12
TB7ZS	TCR2.0	<b>Transmit Side Bit 7 Zero Suppression Enable.</b> 0 = no stuffing occurs 1 = Bit 7 force to a one in channels with all zeros

**Table 6-2 OUTPUT PIN TEST MODES**

TEST 1	TEST 0	EFFECT ON OUTPUT PINS
0	0	operate normally
0	1	force all output pins into 3-state (including all I/O pins and parallel port pins)
1	0	force all output pins low (including all I/O pins except parallel port pins)
1	1	force all output pins high (including all I/O pins except parallel port pins)

**CCR1: COMMON CONTROL REGISTER 1 (Address=37 Hex)**

(MSB)							(LSB)
TESE	ODF	RSAO	TSCLKM	RSCLKM	RESE	PLB	FLB

SYMBOL	POSITION	NAME AND DESCRIPTION
TESE	CCR1.7	<b>Transmit Elastic Store Enable.</b> 0 = elastic store is bypassed 1 = elastic store is enabled
ODF	CCR1.6	<b>Output Data Format.</b> 0 = bipolar data at TPOSO and TNEGO 1 = NRZ data at TPOSO; TNEGO = 0
RSAO	CCR1.5	<b>Receive Signaling All One's.</b> This bit should not be enabled if hardware signaling is being utilized. See Section 10 for more details. 0 = allow robbed signaling bits to appear at RSER 1 = force all robbed signaling bits at RSER to one
TSCLKM	CCR1.4	<b>TSYSCLK Mode Select.</b> 0 = if TSYSCLK is 1.544 MHz 1 = if TSYSCLK is 2.048 MHz or IBO enabled (see section 20 for details on IBO function)
RSCLKM	CCR1.3	<b>RSYSCLK Mode Select.</b> 0 = if RSYSCLK is 1.544 MHz 1 = if RSYSCLK is 2.048 MHz or IBO enabled (see section 20 for details on IBO function)
RESE	CCR1.2	<b>Receive Elastic Store Enable.</b> 0 = elastic store is bypassed 1 = elastic store is enabled
PLB	CCR1.1	<b>Payload Loopback.</b> 0 = loopback disabled 1 = loopback enabled
FLB	CCR1.0	<b>Framer Loopback.</b> 0 = loopback disabled 1 = loopback enabled

**6.3 PAYLOAD LOOPBACK**

Payload Loopback When CCR1.1 is set to a one, the DS21352/552 will be forced into Payload LoopBack (PLB). Normally, this loopback is only enabled when ESF framing is being performed but can be enabled also in D4 framing applications. In a PLB situation, the DS21352/552 will loop the 192 bits of payload data (with BPVs corrected) from the receive section back to the transmit section. The FPS framing pattern, CRC6 calculation, and the FDL bits are not looped back, they are reinserted by the DS21352/552. When PLB is enabled, the following will occur:

1. data will be transmitted from the TPOSO and TNEGO pins synchronous with RCLK instead of TCLK
2. all of the receive side signals will continue to operate normally
3. the TCHCLK and TCHBLK signals are forced low
4. data at the TSER, TDATA, and TSIG pins is ignored
5. the TLCLK signal will become synchronous with RCLK instead of TCLK.

**6.4 FRAMER LOOPBACK**

When CCR1.0 is set to a one, the DS21352/552 will enter a Framer LoopBack (FLB) mode. This loopback is useful in testing and debugging applications. In FLB, the DS21352/552 will loop data from the transmit side back to the receive side. When FLB is enabled, the following will occur:

1. An unframed all one's code will be transmitted at TPOSO and TNEGO
2. Data at RPOSI and RNEGI will be ignored

3. All receive side signals will take on timing synchronous with TCLK instead of RCLKI.

**Please note that it is not acceptable to have RCLK tied to TCLK during this loopback because this will cause an unstable condition.**

## CCR2: COMMON CONTROL REGISTER 2 (Address=38 Hex)

(MSB)								(LSB)
TFM	TB8ZS	TSLC96	TFDL	RFM	RB8ZS	RSLC96	RZSE	
SYMBOL	POSITION	NAME AND DESCRIPTION						
TFM	CCR2.7	<b>Transmit Frame Mode Select.</b> 0 = D4 framing mode 1 = ESF framing mode						
TB8ZS	CCR2.6	<b>Transmit B8ZS Enable.</b> 0 = B8ZS disabled 1 = B8ZS enabled						
TSLC96	CCR2.5	<b>Transmit SLC-96 / Fs-Bit Insertion Enable.</b> Only set this bit to a one in D4 framing applications. Must be set to one to source the Fs pattern from the TFDL register. See Section 15.5 for details. 0 = SLC-96/Fs-bit insertion disabled 1 = SLC-96/Fs-bit insertion enabled						
TFDL	CCR2.4	<b>Transmit FDL Zero Stuffer Enable.</b> Set this bit to zero if using the internal HDLC/BOC controller instead of the legacy support for the FDL. See Section 15 for details. 0 = zero stuffer disabled 1 = zero stuffer enabled						
RFM	CCR2.3	<b>Receive Frame Mode Select.</b> 0 = D4 framing mode 1 = ESF framing mode						
RB8ZS	CCR2.2	<b>Receive B8ZS Enable.</b> 0 = B8ZS disabled 1 = B8ZS enabled						
RSLC96	CCR2.1	<b>Receive SLC-96 Enable.</b> Only set this bit to a one in D4/SLC-96 framing applications. See Section 15.5 for details. 0 = SLC-96 disabled 1 = SLC-96 enabled						
RZSE	CCR2.0	<b>Receive FDL Zero Destuffer Enable.</b> Set this bit to zero if using the internal HDLC/BOC controller instead of the legacy support for the FDL. See Section 15.4 for details. 0 = zero destuffer disabled 1 = zero destuffer enabled						

## CCR3: COMMON CONTROL REGISTER 3 (Address=30 Hex)

(MSB)								(LSB)
RESMDM	TCLKSRC	RLOSF	RSMS	PDE	ECUS	TLOOP	TESMDM	
SYMBOL	POSITION	NAME AND DESCRIPTION						
RESMDM	CCR3.7	<b>Receive Elastic Store Minimum Delay Mode.</b> See Section 14.4 for details. 0 = elastic stores operate at full two frame depth 1 = elastic stores operate at 32-bit depth						
TCLKSRC	CCR3.6	<b>Transmit Clock Source Select.</b> This function allows the user to internally select RCLK as the clock source for the transmit side formatter. 0 = Source of transmit clock determined by TCR1.7 (LOTMC) (LOTMC) 1 = Force transmitter to internally switch to RCLK as source of transmit clock. Signal at TCLK pin is ignored						
RLOSF	CCR3.5	<b>Function of the RLOS/LOT Output.</b> 0 = Receive Loss of Sync (RLOS)						

RSMS	CCR3.4	<p>1 = Loss of Transmit Clock (LOTC)</p> <p><b>RSYNC Multiframe Skip Control.</b> Useful in framing format conversions from D4 to ESF. This function is not available when the receive side elastic store is enabled.</p> <p>0 = RSYNC will output a pulse at every multiframe</p> <p>1 = RSYNC will output a pulse at every other multiframe note: for this bit to have any affect, the RSYNC must be set to output multiframe pulses (RCR2.4=1 and RCR2.3=0).</p>
PDE	CCR3.3	<p><b>Pulse Density Enforcer Enable.</b></p> <p>0 = disable transmit pulse density enforcer</p> <p>1 = enable transmit pulse density enforcer</p>
ECUS	CCR3.2	<p><b>Error Counter Update Select.</b> See Section 8 for details.</p> <p>0 = update error counters once a second</p> <p>1 = update error counters every 42 ms (333 frames)</p>
TLOOP	CCR3.1	<p><b>Transmit Loop Code Enable.</b> See Section 17 for details.</p> <p>0 = transmit data normally</p> <p>1 = replace normal transmitted data with repeating code as defined in TCD register</p>
TESMDM	CCR3.0	<p><b>Transmit Elastic Store Minimum Delay Mode.</b> See Section 14.4 for details.</p> <p>0 = elastic stores operate at full two frame depth</p> <p>1 = elastic stores operate at 32-bit depth</p>

## 6.5 PULSE DENSITY ENFORCER

The Frammer always examines both the transmit and receive data streams for violations of the following rules which are required by ANSI T1.403:

- no more than 15 consecutive zeros
- at least N ones in each and every time window of  $8 \times (N + 1)$  bits where N = 1 through 23

Violations for the transmit and receive data streams are reported in the RIR2.0 and RIR2.1 bits respectively. When the CCR3.3 is set to one, the DS21352 will force the transmitted stream to meet this requirement no matter the content of the transmitted stream. When running B8ZS, the CCR3.3 bit should be set to zero since B8ZS encoded data streams cannot violate the pulse density requirements.

**CCR4: COMMON CONTROL REGISTER 4 (Address=11 Hex)**

(MSB)							(LSB)
RSRE	RPCSI	RFSA1	RFE	RFF	THSE	TPCSI	TIRFS

SYMBOL	POSITION	NAME AND DESCRIPTION
RSRE	CCR4.7	<b>Receive Side Signaling Re-Insertion Enable.</b> See Section 10.2 for details. 0 = do not re-insert signaling bits into the data stream presented at the RSER pin 1 = reinsert the signaling bits into data stream presented at the RSER pin
RPCSI	CCR4.6	<b>Receive Per-Channel Signaling Insert.</b> See Section 10.2 for more details. 0 = do not use RCHBLK to determine which channels should have signaling re-inserted 1 = use RCHBLK to determine which channels should have signaling re-inserted
RFSA1	CCR4.5	<b>Receive Force Signaling All Ones.</b> See Section 10.2 for more details. 0 = do not force extracted robbed-bit signaling bit positions to a one 1 = force extracted robbed-bit signaling bit positions to a one
RFE	CCR4.4	<b>Receive Freeze Enable.</b> See Section 10.2 for details. 0 = no freezing of receive signaling data will occur 1 = allow freezing of receive signaling data at RSIG (and RSER if CCR4.7 = 1).
RFF	CCR4.3	<b>Receive Force Freeze.</b> Freezes receive side signaling at RSIG (and RSER if CCR4.7=1); will override Receive Freeze Enable (RFE). See Section 10.2 for details. 0 = do not force a freeze event 1 = force a freeze event
THSE	CCR4.2	<b>Transmit Hardware Signaling Insertion Enable.</b> See Section 10.2 for details. 0 = do not insert signaling from the TSIG pin into the data stream presented at the TSER pin 1 = insert signaling from the TSIG pin into data stream presented at the TSER pin
TPCSI	CCR4.1	<b>Transmit Per-Channel Signaling Insert.</b> See Section 10.2 for details. 0 = do not use TCHBLK to determine which channels should have signaling inserted from TSIG 1 = use TCHBLK to determine which channels should have signaling inserted from TSIG
TIRFS	CCR4.0	<b>Transmit Idle Registers (TIR) Function Select.</b> See Section 2.1 for timing details. 0 = TIRs define in which channels to insert idle code 1 = TIRs define in which channels to insert data from RSER (i.e., Per-Channel Loopback function)

**CCR5: COMMON CONTROL REGISTER 5 (Address=19 Hex)**

(MSB)						(LSB)	
TJC	LLB	LIAIS	TCM4	TCM3	TCM2	TCM1	TCM0

SYMBOL	POSITION	NAME AND DESCRIPTION
TJC	CCR5.7	<b>Transmit Japanese CRC6 Enable.</b> 0 = use ANSI/AT&T/ITU CRC6 calculation (normal operation) 1 = use Japanese standard JT-G704 CRC6 calculation
LLB	CCR5.6	<b>Local Loopback.</b> 0 = loopback disabled 1 = loopback enabled
LIAIS	CCR5.5	<b>Line Interface AIS Generation Enable.</b> 0 = allow normal data from TPOSI/TNEGI to be transmitted at TTIP and TRING 1 = force unframed all ones to be transmitted at TTIP and TRING
TCM4	CCR5.4	<b>Transmit Channel Monitor Bit 4.</b> MSB of a channel decode that determines which transmit channel data will appear in the TDS0M register. See Section 9 for details.
TCM3	CCR5.3	<b>Transmit Channel Monitor Bit 3.</b>
TCM2	CCR5.2	<b>Transmit Channel Monitor Bit 2.</b>
TCM1	CCR5.1	<b>Transmit Channel Monitor Bit 1.</b>
TCM0	CCR5.0	<b>Transmit Channel Monitor Bit 0.</b> LSB of the channel decode.



**CCR6: COMMON CONTROL REGISTER 6 (Address=1E Hex)**

(MSB)							(LSB)
RJC	RESA	TESA	RCM4	RCM3	RCM2	RCM1	RCM0

SYMBOL	POSITION	NAME AND DESCRIPTION
RJC	CCR6.7	<b>Receive Japanese CRC6 Enable.</b> 0 = use ANSI/AT&T/ITU CRC6 calculation (normal operation) 1 = use Japanese standard JT-G704 CRC6 calculation
RESA	CCR6.6	<b>Receive Elastic Store Align.</b> Setting this bit from a zero to a one will force the receive elastic store's write/read pointers to a minimum separation of half a frame. No action will be taken if the pointer separation is already greater or equal to half a frame. If pointer separation is less than half a frame, the command will be executed and the data will be disrupted. Should be toggled after RSYCLK has been applied and is stable. Must be cleared and set again for a subsequent align. See section 14.3 for details.
TESA	CCR6.5	<b>Transmit Elastic Store Align.</b> Setting this bit from a zero to a one will force the transmit elastic store's write/read pointers to a minimum separation of half a frame. No action will be taken if the pointer separation is already greater or equal to half a frame. If pointer separation is less than half a frame, the command will be executed and the data will be disrupted. Should be toggled after TSYCLK has been applied and is stable. Must be cleared and set again for a subsequent align. See section 14.3 for details.
RCM4	CCR6.4	<b>Receive Channel Monitor Bit 4.</b> MSB of a channel decode that determines which receive channel data will appear in the RDS0M register. See Section 9 for details.
RCM3	CCR6.3	<b>Receive Channel Monitor Bit 3.</b>
RCM2	CCR6.2	<b>Receive Channel Monitor Bit 2.</b>
RCM1	CCR6.1	<b>Receive Channel Monitor Bit 1.</b>
RCM0	CCR6.0	<b>Receive Channel Monitor Bit 0.</b> LSB of the channel decode.

## CCR7: COMMON CONTROL REGISTER 7 (Address=0A Hex)

(MSB)							(LSB)
LIRST	RLB	RESR	TESR	–	LIUSI	CDIG	LIUODO

SYMBOL	POSITION	NAME AND DESCRIPTION
LIRST	CCR7.7	<b>Line Interface Reset.</b> Setting this bit from a zero to a one will initiate an internal reset that affects the clock recovery state machine and jitter attenuator. Normally this bit is only toggled on power-up. Must be cleared and set again for a subsequent reset.
RLB	CCR7.6	<b>Remote Loopback.</b> 0 = loopback disabled 1 = loopback enabled
RESR	CCR7.5	<b>Receive Elastic Store Reset.</b> Setting this bit from a zero to a one will minimize the delay through the receive elastic store. Should be toggled after RSYCLK has been applied and is stable. See section 14.3 for details. Do not leave this bit set HIGH.
TESR	CCR7.4	<b>Transmit Elastic Store Reset.</b> Setting this bit from a zero to a one will maximize the delay through the transmit elastic store. Transmit data is lost during the reset. Should be toggled after TSYCLK has been applied and is stable. See section 14.3 for details. Do not leave this bit set HIGH.
-	CCR7.3	<b>Reserved.</b> Must be set low for proper operation.
LIUSI	CCR7.2	<b>Line Interface Synchronization Interface Enable.</b> This control bit determines whether the line receiver should handle a normal T1 signal or a 1.544MHz synchronization signal. This control has no affect on the line interface transmitter. 0 = line receiver configured to support a normal T1 signal 1 = line receiver configured to support a synchronization signal
CDIG	CCR7.1	<b>Customer Disconnect Indication Generator.</b> This control bit determines whether the Line Interface will generate an unframed ...1010... pattern at TTIP and TRING instead of the normal data pattern. 0 = generate normal data at TTIP & TRING as input via TPOSI & TNEGI 1 = generate a ...1010... pattern at TTIP and TRING
LIUODO	CCR7.0	<b>Line Interface Open Drain Option.</b> This control bit determines whether the TTIP and TRING outputs will be open drain or not. The line driver outputs can be forced open drain to allow 6Vpeak pulses to be generated or to allow the creation of a very low power interface. 0 = allow TTIP and TRING to operate normally 1 = force the TTIP and TRING outputs to be open drain

### 6.6 REMOTE LOOPBACK

When CCR7.6 is set to a one, the DS21352/552 will be forced into Remote LoopBack (RLB). In this loopback, data input via the RPOSI and RNEGI pins will be transmitted back to the TPOSO and TNEGO pins. Data will continue to pass through the receive side framer of the DS21352/552 as it would normally and the data from the transmit side formatter will be ignored. Please see Figure 3-1 for more details.

## 7. STATUS AND INFORMATION REGISTERS

There is a set of nine registers that contain information on the current real time status of the device, Status Register 1 (SR1), Status Register 2 (SR2), Receive Information Registers 1 to 3 (RIR1/RIR2/RIR3) and a set of four registers for the onboard HDLC and BOC controller. The specific details on the four registers pertaining to the HDLC controller are covered in Section 15.3.2 but they operate the same as the other status registers in the DS21352/552 and this operation is described below.

When a particular event has occurred (or is occurring), the appropriate bit in one of these nine registers will be set to a one. All of the bits in SR1, SR2, RIR1, RIR2, and RIR3 registers operate in a latched fashion. This means that if an event or an alarm occurs and a bit is set to a one in any of the registers, it will remain set until the user reads that bit. The bit will be cleared when it is read and it will not be set again until the event has occurred again (or in the case of the RBL, RYEL, LRCL, and RLOS alarms, the bit will remain set if the alarm is still present). There are bits in the four HDLC status registers that are not latched and these bits are listed in Section 15.3.2.

The user will always proceed a read of any of the nine registers with a write. The byte written to the register will inform the DS21352/552 which bits the user wishes to read and have cleared. The user will write a byte to one of these registers, with a one in the bit positions he or she wishes to read and a zero in the bit positions he or she does not wish to obtain the latest information on. When a one is written to a bit location, the read register will be updated with the latest information. When a zero is written to a bit position, the read register will not be updated and the previous value will be held. A write to the status and information registers will be immediately followed by a read of the same register. The read result should be logically AND'ed with the mask byte that was just written and this value should be written back into the same register to insure that bit does indeed clear. This second write step is necessary because the alarms and events in the status registers occur asynchronously in respect to their access via the parallel port. This write-read-write scheme allows an external microcontroller or microprocessor to individually poll certain bits without disturbing the other bits in the register. This operation is key in controlling the DS21352/552 with higher-order software languages.

The SR1, SR2, and HSR registers have the unique ability to initiate a hardware interrupt via the INT output pin. Each of the alarms and events in the SR1, SR2, and HSR can be either masked or unmasked from the interrupt pin via the Interrupt Mask Register 1 (IMR1), Interrupt Mask Register 2 (IMR2), and HDLC Interrupt Mask Register (HIMR) respectively. The HIMR register is covered in Section 15.3.2.

The interrupts caused by alarms in SR1 (namely RYEL, LRCL, RBL, and RLOS) act differently than the interrupts caused by events in SR1 and SR2 (namely LUP, LDN, LOTC, RSLIP, RMF, TMF, SEC, RFDL, TFDL, RMTCH, RAF, and RSC) and HIMR. The alarm caused interrupts will force the INT pin low whenever the alarm changes state (i.e., the alarm goes active or inactive according to the set/clear criteria in Table 7-2). The INT pin will be allowed to return high (if no other interrupts are present) when the user reads the alarm bit that caused the interrupt to occur even if the alarm is still present. The event caused interrupts will force the INT pin low when the event occurs. The INT pin will be allowed to return high (if no other interrupts are present) when the user reads the event bit that caused the interrupt to occur.

**RIR1: RECEIVE INFORMATION REGISTER 1 (Address=22 Hex)**

(MSB)							(LSB)
COFA	8ZD	16ZD	RESF	RESE	SEFE	B8ZS	FBE

SYMBOL	POSITION	NAME AND DESCRIPTION
COFA	RIR1.7	<b>Change of Frame Alignment.</b> Set when the last resync resulted in a change of frame or multiframe alignment.
8ZD	RIR1.6	<b>Eight Zero Detect.</b> Set when a string of at least eight consecutive zeros (regardless of the length of the string) have been received at RPOSI and RNEGI.
16ZD	RIR1.5	<b>Sixteen Zero Detect.</b> Set when a string of at least sixteen consecutive zeros (regardless of the length of the string) have been received at RPOSI and RNEGI.
RESF	RIR1.4	<b>Receive Elastic Store Full.</b> Set when the receive elastic store buffer fills and a frame is deleted.
RESE	RIR1.3	<b>Receive Elastic Store Empty.</b> Set when the receive elastic store buffer empties and a frame is repeated.
SEFE	RIR1.2	<b>Severely Errored Framing Event.</b> Set when 2 out of 6 framing bits (Ft or FPS) are received in error.
B8ZS	RIR1.1	<b>B8ZS Code Word Detect.</b> Set when a B8ZS code word is detected at RPOSI and RNEGI independent of whether the B8ZS mode is selected or not via CCR2.6. Useful for automatically setting the line coding.
FBE	RIR1.0	<b>Frame Bit Error.</b> Set when a Ft (D4) or FPS (ESF) framing bit is received in error.

**RIR2: RECEIVE INFORMATION REGISTER 2 (Address=31 Hex)**

(MSB)						(LSB)	
RLOSC	LRCLC	TESF	TESE	TSLIP	RBLC	RPDV	TPDV

SYMBOL	POSITION	NAME AND DESCRIPTION
RLOSC	RIR2.7	<b>Receive Loss of Sync Clear.</b> Set when the framer achieves synchronization; will remain set until read.
LRCLC	RIR2.6	<b>Line Interface Receive Carrier Loss Clear.</b> Set when the carrier signal is restored; will remain set until read. See Table 7-2.
TESF	RIR2.5	<b>Transmit Elastic Store Full.</b> Set when the transmit elastic store buffer fills and a frame is deleted.
TESE	RIR2.4	<b>Transmit Elastic Store Empty.</b> Set when the transmit elastic store buffer empties and a frame is repeated.
TSLIP	RIR2.3	<b>Transmit Elastic Store Slip Occurrence.</b> Set when the transmit elastic store has either repeated or deleted a frame.
RBLC	RIR2.2	<b>Receive Blue Alarm Clear.</b> Set when the Blue Alarm (AIS) is no longer detected; will remain set until read. See Table 7-2.
RPDV	RIR2.1	<b>Receive Pulse Density Violation.</b> Set when the receive data stream does not meet the ANSI T1.403 requirements for pulse density.
TPDV	RIR2.0	<b>Transmit Pulse Density Violation.</b> Set when the transmit data stream does not meet the ANSI T1.403 requirements for pulse density.

**RIR3: RECEIVE INFORMATION REGISTER 3 (Address=10 Hex)**

(MSB)						(LSB)	
RL1	RL0	JALT	LORC	FRCL	–	–	–

SYMBOL	POSITION	NAME AND DESCRIPTION
RL1	RIR3.7	<b>Receive Level Bit 1.</b> See Table 7-1.
RL0	RIR3.6	<b>Receive Level Bit 0.</b> See Table 7-1.
JALT	RIR3.5	<b>Jitter Attenuator Limit Trip.</b> Set when the jitter attenuator FIFO reaches to within 4

LORC	RIR3.4	bits of its limit; useful for debugging jitter attenuation operation. <b>Loss of Receive Clock.</b> Set when the RCLKI pin has not transitioned for at least 2 $\mu$ s (4 $\mu$ s max).
FRCL	RIR3.3	<b>Framer Receive Carrier Loss.</b> Set when 192 consecutive zeros have been received at the RPOSI and RNEGI pins; allowed to be cleared when 14 or more ones out of 112 possible bit positions are received.
–	RIR3.2	<b>Not Assigned.</b> Could be any value when read.
–	RIR3.1	<b>Not Assigned.</b> Could be any value when read.
–	RIR3.0	<b>Not Assigned.</b> Could be any value when read.

**Table 7-1 RECEIVE T1 LEVEL INDICATION**

RL1	RL0	TYPICAL LEVEL RECEIVED
0	0	+2 dB to –7.5 dB
0	1	–7.5 dB to –15 dB
1	0	–15 dB to –22.5 dB
1	1	less than –22.5 dB

**SR1: STATUS REGISTER 1 (Address=20 Hex)**

(MSB)						(LSB)	
LUP	LDN	LOTCL	RSLIP	RBL	RYEL	LRCL	RLOS

SYMBOL	POSITION	NAME AND DESCRIPTION
LUP	SR1.7	<b>Loop Up Code Detected.</b> Set when the loop up code as defined in the RUPCD register is being received. See Section 16.5 for details.
LDN	SR1.6	<b>Loop Down Code Detected.</b> Set when the loop down code as defined in the RDNCD register is being received. See Section 16.5 for details.
LOTCL	SR1.5	<b>Loss of Transmit Clock.</b> Set when the TCLK pin has not transitioned for one channel time (or 5.2 $\mu$ s). Will force the RLOS/LOTCL pin high if enabled via CCR1.6. Also will force transmit side formatter to switch to RCLK if so enabled via TCR1.7.
RSLIP	SR1.4	<b>Receive Elastic Store Slip Occurrence.</b> Set when the receive elastic store has either repeated or deleted a frame.
RBL	SR1.3	<b>Receive Blue Alarm.</b> Set when an unframed all one's code is received at RPOSI and RNEGI.
RYEL	SR1.2	<b>Receive Yellow Alarm.</b> Set when a yellow alarm is received at RPOSI and RNEGI.
LRCL	SR1.1	<b>Line Interface Receive Carrier Loss.</b> Set when a red alarm is received at RTIP and RRING.
RLOS	SR1.0	<b>Receive Loss of Sync.</b> Set when the device is not synchronized to the receive T1 stream.

**Table 7-2 ALARM CRITERIA**

ALARM	SET CRITERIA	CLEAR CRITERIA
<b>Blue Alarm (AIS)</b> (see note 1 below)	when over a 3 ms window, 5 or less zeros are received	when over a 3 ms window, 6 or more zeros are received
<b>Yellow Alarm (RAI)</b> 1. D4 bit 2 mode(RCR2.2=0)  2. D4 12th F-bit mode (RCR2.2=1; this mode is also referred to as the “Japanese Yellow Alarm”)  3. ESF mode	when bit 2 of 256 consecutive channels is set to zero for at least 254 occurrences  when the 12th framing bit is set to one for two consecutive occurrences  when 16 consecutive patterns of 00FF appear in the FDL	when bit 2 of 256 consecutive channels is set to zero for less than 254 occurrences  when the 12th framing bit is set to zero for two consecutive occurrences  when 14 or less patterns of 00FF hex out of 16 possible appear in the FDL
<b>Red Alarm (LRCL)</b> (this alarm is also referred to as Loss Of Signal)	when 192 consecutive zeros are received	when 14 or more ones out of 112 possible bit positions are received starting with the first one received

**NOTES:**

1. The definition of Blue Alarm (or Alarm Indication Signal) is an unframed all ones signal. Blue alarm detectors should be able to operate properly in the presence of a  $10E-3$  error rate and they should not falsely trigger on a framed all ones signal. The blue alarm criteria in the DS21352/552 has been set to achieve this performance. It is recommended that the RBL bit be qualified with the RLOS bit.

2. ANSI specifications use a different nomenclature than the DS21352/552 does; the following terms are equivalent:

RBL = AIS  
RCL = LOS  
RLOS = LOF  
RYEL = RAI

**SR2: STATUS REGISTER 2 (Address=21 Hex)**

(MSB)						(LSB)	
RMF	TMF	SEC	RFDL	TFDL	RMTCH	RAF	RSC

SYMBOL	POSITION	NAME AND DESCRIPTION
RMF	SR2.7	<b>Receive Multiframe.</b> Set on receive multiframe boundaries.
TMF	SR2.6	<b>Transmit Multiframe.</b> Set on transmit multiframe boundaries.
SEC	SR2.5	<b>One Second Timer.</b> Set on increments of one second based on RCLK; will be set in increments of 999 ms, 999 ms, and 1002 ms every 3 seconds.
RFDL	SR2.4	<b>Receive FDL Buffer Full.</b> Set when the receive FDL buffer (RFDL) fills to capacity (8 bits).
TFDL	SR2.3	<b>Transmit FDL Buffer Empty.</b> Set when the transmit FDL buffer (TFDL) empties.
RMTCH	SR2.2	<b>Receive FDL Match Occurrence.</b> Set when the RFDL matches either RFDLM1 or RFDLM2.
RAF	SR2.1	<b>Receive FDL Abort.</b> Set when eight consecutive one's are received in the FDL.
RSC	SR2.0	<b>Receive Signaling Change.</b> Set when the DS21352/552 detects a change of state in any of the robbed-bit signaling bits.



**IMR1: INTERRUPT MASK REGISTER 1 (Address=7F Hex)**

(MSB)							(LSB)
LUP	LDN	LOTC	SLIP	RBL	RYEL	LRCL	RLOS

SYMBOL	POSITION	NAME AND DESCRIPTION
LUP	IMR1.7	<b>Loop Up Code Detected.</b> 0 = interrupt masked 1 = interrupt enabled
LDN	IMR1.6	<b>Loop Down Code Detected.</b> 0 = interrupt masked 1 = interrupt enabled
LOTC	IMR1.5	<b>Loss of Transmit Clock.</b> 0 = interrupt masked 1 = interrupt enabled
SLIP	IMR1.4	<b>Elastic Store Slip Occurrence.</b> 0 = interrupt masked 1 = interrupt enabled
RBL	IMR1.3	<b>Receive Blue Alarm.</b> 0 = interrupt masked 1 = interrupt enabled
RYEL	IMR1.2	<b>Receive Yellow Alarm.</b> 0 = interrupt masked 1 = interrupt enabled
LRCL	IMR1.1	<b>Line Interface Receive Carrier Loss.</b> 0 = interrupt masked 1 = interrupt enabled
RLOS	IMR1.0	<b>Receive Loss of Sync.</b> 0 = interrupt masked 1 = interrupt enabled

**IMR2: INTERRUPT MASK REGISTER 2 (Address=6F Hex)**

(MSB)						(LSB)	
RMF	TMF	SEC	RFDL	TFDL	RMTCH	RAF	RSC

SYMBOL	POSITION	NAME AND DESCRIPTION
RMF	IMR2.7	<b>Receive Multiframe.</b> 0 = interrupt masked 1 = interrupt enabled
TMF	IMR2.6	<b>Transmit Multiframe.</b> 0 = interrupt masked 1 = interrupt enabled
SEC	IMR2.5	<b>One Second Timer.</b> 0 = interrupt masked 1 = interrupt enabled
RFDL	IMR2.4	<b>Receive FDL Buffer Full.</b> 0 = interrupt masked 1 = interrupt enabled
TFDL	IMR2.3	<b>Transmit FDL Buffer Empty.</b> 0 = interrupt masked 1 = interrupt enabled
RMTCH	IMR2.2	<b>Receive FDL Match Occurrence.</b> 0 = interrupt masked 1 = interrupt enabled
RAF	IMR2.1	<b>Receive FDL Abort.</b> 0 = interrupt masked 1 = interrupt enabled
RSC	IMR2.0	<b>Receive Signaling Change.</b> 0 = interrupt masked 1 = interrupt enabled

**8. ERROR COUNT REGISTERS**

There are a set of three counters that record bipolar violations, excessive zeros, errors in the CRC6 code words, framing bit errors, and number of multiframe that the device is out of receive synchronization. Each of these three counters are automatically updated on either one second boundaries (CCR3.2=0) or every 42 ms (CCR3.2=1) as determined by the timer in Status Register 2 (SR2.5). Hence, these registers contain performance data from either the previous second or the previous 42 ms. The user can use the interrupt from the one second timer to determine when to read these registers. The user has a full second (or 42 ms) to read the counters before the data is lost. All three counters will saturate at their respective maximum counts and they will not rollover (note: only the Line Code Violation Count Register has the potential to over-flow but the bit error would have to exceed 10E-2 before this would occur).

## 8.1 LINE CODE VIOLATION COUNT REGISTER (LCVCR)

Line Code Violation Count Register 1 (LCVCR1) is the most significant word and LCVCR2 is the least significant word of a 16-bit counter that records code violations (CVs). CVs are defined as Bipolar Violations (BPVs) or excessive zeros. See Table 8-1 for details of exactly what the LCVCRs count. If the B8ZS mode is set for the receive side via CCR2.2, then B8ZS code words are not counted. This counter is always enabled; it is not disabled during receive loss of synchronization (RLOS=1) conditions.

**LCVCR1: LINE CODE VIOLATION COUNT REGISTER 1 (Address = 23 Hex)**

**LCVCR2: LINE CODE VIOLATION COUNT REGISTER 2 (Address = 24 Hex)**

(MSB)				(LSB)				
LCV15	LCV14	LCV13	LCV12	LCV11	LCV10	LCV9	LCV8	LCVCR1
LCV7	LCV6	LCV5	LCV4	LCV3	LCV2	LCV1	LCV0	LCVCR2

SYMBOL	POSITION	NAME AND DESCRIPTION
LCV15	LCVCR1.7	MSB of the 16-bit code violation count
LCV0	LCVCR2.0	LSB of the 16-bit code violation count

**Table 8-1 LINE CODE VIOLATION COUNTING ARRANGEMENTS**

COUNT EXCESSIVE ZEROS (RCR1.7)	B8ZS ENABLED (CCR2.2)	WHAT IS COUNTED IN THE LCVCRs
no	no	BPVs
yes	no	BPVs + 16 consecutive zeros
no	yes	BPVs (B8ZS code words not counted)
yes	yes	BPV's + 8 consecutive zeros

## 8.2 PATH CODE VIOLATION COUNT REGISTER (PCVCR)

When the receive side of a framer is set to operate in the ESF framing mode (CCR2.3=1), PCVCR will automatically be set as a 12-bit counter that will record errors in the CRC6 code words. When set to operate in the D4 framing mode (CCR2.3=0), PCVCR will automatically count errors in the Ft framing bit position. Via the RCR2.1 bit, a framer can be programmed to also report errors in the Fs framing bit position. The PCVCR will be disabled during receive loss of synchronization (RLOS=1) conditions. See Table 8-2 for a detailed description of exactly what errors the PCVCR counts.

### PCVCR1: PATH VIOLATION COUNT REGISTER 1 (Address = 25 Hex)

### PCVCR2: PATH VIOLATION COUNT REGISTER 2 (Address = 26 Hex)

(MSB)				(LSB)				
(note 1)	(note 1)	(note 1)	(note 1)	CRC/FB11	CRC/FB10	CRC/FB9	CRC/FB8	PCVCR1
CRC/FB7	CRC/FB6	CRC/FB5	CRC/FB4	CRC/FB3	CRC/FB2	CRC/FB1	CRC/FB0	PCVCR2

SYMBOL	POSITION	NAME AND DESCRIPTION
CRC/FB11	PCVCR1.3	MSB of the 12-Bit CRC6 Error or Frame Bit Error Count (note #2)
CRC/FB0	PCVCR2.0	LSB of the 12-Bit CRC6 Error or Frame Bit Error Count (note #2)

### NOTES:

1. The upper nibble of the counter at address 25 is used by the Multiframes Out of Sync Count Register
2. PCVCR counts either errors in CRC code words (in the ESF framing mode; CCR2.3=1) or errors in the framing bit position (in the D4 framing mode; CCR2.3=0).

**Table 8.2 PATH CODE VIOLATION COUNTING ARRANGEMENTS**

FRAMING MODE (CCR2.3)	COUNT Fs ERRORS (RCR2.1)	WHAT IS COUNTED IN THE PCVCRs
D4	no	errors in the Ft pattern
D4	yes	errors in both the Ft & Fs patterns
ESF	don't care	errors in the CRC6 code words

### 8.3 Multiframe Out Of Sync Count Register (MOSCR)

Normally the MOSCR is used to count the number of multiframe that the receive synchronizer is out of sync (RCR2.0=1). This number is useful in ESF applications needing to measure the parameters Loss Of Frame Count (LOFC) and ESF Error Events as described in AT&T publication TR54016. When the MOSCR is operated in this mode, it is not disabled during receive loss of synchronization (RLOS=1) conditions. The MOSCR has alternate operating mode whereby it will count either errors in the Ft framing pattern (in the D4 mode) or errors in the FPS framing pattern (in the ESF mode). When the MOSCR is operated in this mode, it is disabled during receive loss of synchronization (RLOS = 1) conditions. See Table 8-3 for a detailed description of what the MOSCR is capable of counting.

**MOSCR1: MULTIFRAMES OUT OF SYNC COUNT REGISTER 1 (Address = 25 Hex) see note 1**

**MOSCR2: MULTIFRAMES OUT OF SYNC COUNT REGISTER 2 (Address = 27 Hex)**

(MSB)				(LSB)				
MOS/FB1 1	MOS/FB1 0	MOS/FB9	MOS/FB8	(note 1)	(note 1)	(note 1)	(note 1)	MOSCR1
CRC/FB7	CRC/FB6	CRC/FB5	CRC/FB4	CRC/FB3	CRC/FB2	CRC/FB1	CRC/FB0	MOSCR2

#### SYMBOL      POSITION      NAME AND DESCRIPTION

MOS/FB11      MOSCR1.7      **MSB of the 12–Bit Multiframe Out of Sync or F–Bit Error Count** (note #2)  
MOS/FB0      MOSCR2.0      **LSB of the 12–Bit Multiframe Out of Sync or F–Bit Error Count** (note #2)

#### NOTES:

1. The lower nibble of the counter at address 25 is used by the Path Code Violation Count Register
2. MOSCR counts either errors in framing bit position (RCR2.0=0) or the number of multiframe out of sync (RCR2.0=1)

**Table 8-3 MULTIFRAMES OUT OF SYNC COUNTING ARRANGEMENTS**

FRAMING MODE (CCR2.3)	COUNT MOS OR F–BIT ERRORS (RCR2.0)	WHAT IS COUNTED IN THE MOSCRs
D4	MOS	number of multiframe out of sync
D4	F–Bit	errors in the Ft pattern
ESF	MOS	number of multiframe out of sync
ESF	F–Bit	errors in the FPS pattern

## 9. DS0 MONITORING FUNCTION

The device has the ability to monitor one DS0 64kbps channel in the transmit direction and one DS0 channel in the receive direction at the same time. In the transmit direction the user will determine which channel is to be monitored by properly setting the TCM0 to TCM4 bits in the CCR5 register. In the receive direction, the RCM0 to RCM4 bits in the CCR6 register need to be properly set. The DS0 channel pointed to by the TCM0 to TCM4 bits will appear in the Transmit DS0 Monitor (TDS0M) register and the DS0 channel pointed to by the RCM0 to RCM4 bits will appear in the Receive DS0 (RDS0M) register. The TCM4 to TCM0 and RCM4 to RCM0 bits should be programmed with the decimal decode of the appropriate T1 channel. For example, if DS0 channel 6 in the transmit direction and DS0 channel 15 in the receive direction needed to be monitored, then the following values would be programmed into CCR5 and CCR6:

```
TCM4 = 0      RCM4 = 0
TCM3 = 0      RCM3 = 1
TCM2 = 1      RCM2 = 1
TCM1 = 0      RCM1 = 1
TCM0 = 1      RCM0 = 0
```

### CCR5: COMMON CONTROL REGISTER 5 (Address=19 Hex)

[repeated here from section 6 for convenience]

(MSB)				(LSB)			
TJC	LLB	LIAIS	TCM4	TCM3	TCM2	TCM1	TCM0

SYMBOL	POSITION	NAME AND DESCRIPTION
TJC	CCR5.7	<b>Transmit Japanese CRC6 Enable.</b>
LLB	CCR5.6	<b>Local Loopback.</b>
LIAIS	CCR5.5	<b>Line Interface AIS Generation Enable.</b>
TCM4	CCR5.4	<b>Transmit Channel Monitor Bit 4.</b> MSB of a channel decode that determines which transmit channel data will appear in the TDS0M register. See Section 0 for details.
TCM3	CCR5.3	<b>Transmit Channel Monitor Bit 3.</b>
TCM2	CCR5.2	<b>Transmit Channel Monitor Bit 2.</b>
TCM1	CCR5.1	<b>Transmit Channel Monitor Bit 1.</b>
TCM0	CCR5.0	<b>Transmit Channel Monitor Bit 0.</b> LSB of the channel decode.

**TDS0M: TRANSMIT DS0 MONITOR REGISTER (Address=1A Hex)**

(MSB)							(LSB)
B1	B2	B3	B4	B5	B6	B7	B8

SYMBOL	POSITION	NAME AND DESCRIPTION
B1	TDS0M.7	<b>Transmit DS0 Channel Bit 1.</b> MSB of the DS0 channel (first bit to be transmitted).
B2	TDS0M.6	<b>Transmit DS0 Channel Bit 2.</b>
B3	TDS0M.5	<b>Transmit DS0 Channel Bit 3.</b>
B4	TDS0M.4	<b>Transmit DS0 Channel Bit 4.</b>
B5	TDS0M.3	<b>Transmit DS0 Channel Bit 5.</b>
B6	TDS0M.2	<b>Transmit DS0 Channel Bit 6.</b>
B7	TDS0M.1	<b>Transmit DS0 Channel Bit 7.</b>
B8	TDS0M.0	<b>Transmit DS0 Channel Bit 8.</b> LSB of the DS0 channel (last bit to be transmitted).

**CCR6: COMMON CONTROL REGISTER 6 (Address=1E Hex)**

[repeated here from section 6 for convenience]

(MSB)							(LSB)
RJC	RESA	TESA	RCM4	RCM3	RCM2	RCM1	RCM0

SYMBOL	POSITION	NAME AND DESCRIPTION
RJC	CCR6.7	<b>Receive Japanese CRC Enable.</b>
RESA	CCR6.6	<b>Receive Elastic Store Align.</b>
TESA	CCR6.5	<b>Transmit Elastic Store Align.</b>
RCM4	CCR6.4	<b>Receive Channel Monitor Bit 4.</b> MSB of a channel decode that determines which receive DS0 channel data will appear in the RDS0M register.
RCM3	CCR6.3	<b>Receive Channel Monitor Bit 3.</b>
RCM2	CCR6.2	<b>Receive Channel Monitor Bit 2.</b>
RCM1	CCR6.1	<b>Receive Channel Monitor Bit 1.</b>
RCM0	CCR6.0	<b>Receive Channel Monitor Bit 0.</b> LSB of the channel decode that determines which receive DS0 channel data will appear in the RDS0M register.

**RDS0M: RECEIVE DS0 MONITOR REGISTER (Address=1F Hex)**

(MSB)							(LSB)
B1	B2	B3	B4	B5	B6	B7	B8

SYMBOL	POSITION	NAME AND DESCRIPTION
B1	RDS0M.7	<b>Receive DS0 Channel Bit 1.</b> MSB of the DS0 channel (first bit to be received).
B2	RDS0M.6	<b>Receive DS0 Channel Bit 2.</b>
B3	RDS0M.5	<b>Receive DS0 Channel Bit 3.</b>
B4	RDS0M.4	<b>Receive DS0 Channel Bit 4.</b>

---

B5	RDS0M.3	<b>Receive DS0 Channel Bit 5.</b>
B6	RDS0M.2	<b>Receive DS0 Channel Bit 6.</b>
B7	RDS0M.1	<b>Receive DS0 Channel Bit 7.</b>
B8	RDS0M.0	<b>Receive DS0 Channel Bit 8.</b> LSB of the DS0 channel (last bit to be received).

## 10. SIGNALING OPERATION

Processor based (i.e., software based) signaling access and hardware based access are available. Processor based access and hardware based access can be used simultaneously if necessary. The processor based signaling is covered in Section 10-1 and the hardware based signaling is covered in Section 10-2.

### 10.1 PROCESSOR BASED SIGNALING

The robbed-bit signaling bits embedded in the T1 stream can be extracted from the receive stream and inserted into the transmit stream by each framer. There is a set of 12 registers for the receive side (RS1 to RS12) and 12 registers on the transmit side (TS1 to TS12). The signaling registers are detailed below. The CCR1.5 bit is used to control the robbed signaling bits as they appear at RSER. If CCR1.5 is set to zero, then the robbed signaling bits will appear at the RSER pin in their proper position as they are received. If CCR1.5 is set to a one, then the robbed signaling bit positions will be forced to a one at RSER. If hardware based signaling is being used, then CCR1.5 must be set to zero.



**RS1 TO RS12: RECEIVE SIGNALING REGISTERS (Address=60 to 6B Hex)**

(MSB)				(LSB)				
A(8)	A(7)	A(6)	A(5)	A(4)	A(3)	A(2)	A(1)	RS1 (60)
A(16)	A(15)	A(14)	A(13)	A(12)	A(11)	A(10)	A(9)	RS2 (61)
A(24)	A(23)	A(22)	A(21)	A(20)	A(19)	A(18)	A(17)	RS3 (62)
B(8)	B(7)	B(6)	B(5)	B(4)	B(3)	B(2)	B(1)	RS4 (63)
B(16)	B(15)	B(14)	B(13)	B(12)	B(11)	B(10)	B(9)	RS5 (64)
B(24)	B(23)	B(22)	B(21)	B(20)	B(19)	B(18)	B(17)	RS6 (65)
A/C(8)	A/C(7)	A/C(6)	A/C(5)	A/C(4)	A/C(3)	A/C(2)	A/C(1)	RS7 (66)
A/C(16)	A/C(15)	A/C(14)	A/C(13)	A/C(12)	A/C(11)	A/C(10)	A/C(9)	RS8 (67)
A/C(24)	A/C(23)	A/C(22)	A/C(21)	A/C(20)	A/C(19)	A/C(18)	A/C(17)	RS9 (68)
B/D(8)	B/D(7)	B/D(6)	B/D(5)	B/D(4)	B/D(3)	B/D(2)	B/D(1)	RS10 (69)
B/D(16)	B/D(15)	B/D(14)	B/D(13)	B/D(12)	B/D(11)	B/D(10)	B/D(9)	RS11 (6A)
B/D(24)	B/D(23)	B/D(22)	B/D(21)	B/D(20)	B/D(19)	B/D(18)	B/D(17)	RS12 (6B)

SYMBOL	POSITION	NAME AND DESCRIPTION
--------	----------	----------------------

D(24)	RS12.7	<b>Signaling Bit D in Channel 24</b>
-------	--------	--------------------------------------

A(1)	RS1.0	<b>Signaling Bit A in Channel 1</b>
------	-------	-------------------------------------

Each Receive Signaling Register (RS1 to RS12) reports the incoming robbed bit signaling from eight DS0 channels. In the ESF framing mode, there can be up to four signaling bits per channel (A, B, C, and D). In the D4 framing mode, there are only two signaling bits per channel (A and B). In the D4 framing mode, the framer will replace the C and D signaling bit positions with the A and B signaling bits from the previous multiframe. Hence, whether the framer is operated in either framing mode, the user needs only to retrieve the signaling bits every 3 ms. The bits in the Receive Signaling Registers are updated on multiframe boundaries so the user can utilize the Receive Multiframe Interrupt in the Receive Status Register 2 (SR2.7) to know when to retrieve the signaling bits. The Receive Signaling Registers are frozen and not updated during a loss of sync condition (SR1.0=1). They will contain the most recent signaling information before the “OOF” occurred. The signaling data reported in RS1 to RS12 is also available at the RSIG and RSER pins.

A change in the signaling bits from one multiframe to the next will cause the RSC status bit (SR2.0) to be set. The user can enable the INT pin to toggle low upon detection of a change in signaling by setting the IMR2.0 bit. Once a signaling change has been detected, the user has at least 2.75 ms to read the data out of the RS1 to RS12 registers before the data will be lost.

**TS1 TO TS12: TRANSMIT SIGNALING REGISTERS (Address=70 to 7B Hex)**

(MSB)				(LSB)				
A(8)	A(7)	A(6)	A(5)	A(4)	A(3)	A(2)	A(1)	TS1 (70)
A(16)	A(15)	A(14)	A(13)	A(12)	A(11)	A(10)	A(9)	TS2 (71)
A(24)	A(23)	A(22)	A(21)	A(20)	A(19)	A(18)	A(17)	TS3 (72)
B(8)	B(7)	B(6)	B(5)	B(4)	B(3)	B(2)	B(1)	TS4 (73)
B(16)	B(15)	B(14)	B(13)	B(12)	B(11)	B(10)	B(9)	TS5 (74)
B(24)	B(23)	B(22)	B(21)	B(20)	B(19)	B(18)	B(17)	TS7 (75)
A/C(8)	A/C(7)	A/C(6)	A/C(5)	A/C(4)	A/C(3)	A/C(2)	A/C(1)	TS7 (76)
A/C(16)	A/C(15)	A/C(14)	A/C(13)	A/C(12)	A/C(11)	A/C(10)	A/C(9)	TS8 (77)
A/C(24)	A/C(23)	A/C(22)	A/C(21)	A/C(20)	A/C(19)	A/C(18)	A/C(17)	TS9 (78)
B/D(8)	B/D(7)	B/D(6)	B/D(5)	B/D(4)	B/D(3)	B/D(2)	B/D(1)	TS10 (79)
B/D(16)	B/D(15)	B/D(14)	B/D(13)	B/D(12)	B/D(11)	B/D(10)	B/D(9)	TS11 (7A)
B/D(24)	B/D(23)	B/D(22)	B/D(21)	B/D(20)	B/D(19)	B/D(18)	B/D(17)	TS12 (7B)

SYMBOL	POSITION	NAME AND DESCRIPTION
--------	----------	----------------------

D(24)	TS12.7	<b>Signaling Bit D in Channel 24</b>
-------	--------	--------------------------------------

A(1)	TS1.0	<b>Signaling Bit A in Channel 1</b>
------	-------	-------------------------------------

Each Transmit Signaling Register (TS1 to TS12) contains the Robbed Bit signaling for eight DS0 channels that will be inserted into the outgoing stream if enabled to do so via TCR1.4. In the ESF framing mode, there can be up to four signaling bits per channel (A, B, C, and D). On multiframe boundaries, the framer will load the values present in the Transmit Signaling Register into an outgoing signaling shift register that is internal to the device. The user can utilize the Transmit Multiframe Interrupt in Status Register 2 (SR2.6) to know when to update the signaling bits. In the ESF framing mode, the interrupt will come every 3 ms and the user has a full 3ms to update the TSRs. In the D4 framing mode, there are only two signaling bits per channel (A and B). However in the D4 framing mode, the framer uses the C and D bit positions as the A and B bit positions for the next multiframe. The framer will load the values in the TSRs into the outgoing shift register every other D4 multiframe.

## 10.2 HARDWARE BASED SIGNALING

### 10.2.1 RECEIVE SIDE

In the receive side of the hardware based signaling, there are two operating modes for the signaling buffer; signaling extraction and signaling re-insertion. Signaling extraction involves pulling the signaling bits from the receive data stream and buffering them over a four multiframe buffer and outputting them in a serial PCM fashion on a channel-by-channel basis at the RSIG output. This mode is always enabled. In this mode, the receive elastic store may be enabled or disabled. If the receive elastic store is enabled, then the backplane clock (RSYCLK) can be either 1.544 MHz or 2.048 MHz. In the ESF framing mode, the ABCD signaling bits are output on RSIG in the lower nibble of each channel. The RSIG data is updated once a multiframe (3 ms) unless a freeze is in effect. In the D4 framing mode, the AB signaling bits are output twice on RSIG in the lower nibble of each channel. Hence, bits 5 and 6 contain the same data as bits 7 and 8 respectively in each channel. The RSIG data is updated once a multiframe (1.5 ms) unless a freeze is in effect. See the timing diagrams in Section 21 for some examples.

#### 10.2.1.1 RECEIVE SIGNALING RE-INSERTION

The other hardware based signaling operating mode called signaling re-insertion can be invoked by setting the RSRE control bit high (CCR4.7=1). In this mode, the user will provide a multiframe sync at the RSYNC pin and the signaling data will be re-aligned at the RSER output according to this applied

multiframe boundary. In this mode, the elastic store must be enabled however the backplane clock can be either 1.544 MHz or 2.048 MHz.

If the signaling re-insertion mode is enabled, the user can control which channels have signaling re-insertion performed on a channel-by-channel basis by setting the RPCSI control bit high (CCR4.6) and then programming the RCHBLK output pin to go high in the channels in which the signaling re-insertion should not occur. If the RPCSI bit is set low, then signaling re-insertion will occur in all channels when the signaling re-insertion mode is enabled (RSRE=1). How to control the operation of the RCHBLK output pin is covered in Section 13.

### 10.2.1.2 RECEIVE SIGNALING ALL ONES

In both hardware based signaling operating modes, the user has the option to replace all of the extracted robbed-bit signaling bit positions with ones. This option is enabled via the RFSA1 control bit (CCR4.5) and it can be invoked on a per-channel basis by setting the RPCSI control bit (CCR4.6) high and then programming RCHBLK appropriately just like the per-channel signaling re-insertion operates.

### 10.2.1.3 RECEIVE SIGNALING FREEZE

The signaling data in the four multiframe buffer will be frozen in a known good state upon either a loss of synchronization (OOF event), carrier loss, or frame slip. This action meets the requirements of BellCore TR- TSY-000170 for signaling freezing. To allow this freeze action to occur, the RFE control bit (CCR4.4) should be set high. The user can force a freeze by setting the RFF control bit (CCR4.3) high. The RSIGF output pin provides a hardware indication that a freeze is in effect. The four multiframe buffer provides a three multiframe delay in the signaling bits provided at the RSIG pin (and at the RSER pin if RSRE=1). When freezing is enabled (RFE=1), the signaling data will be held in the last known good state until the corrupting error condition subsides. When the error condition subsides, the signaling data will be held in the old state for at least an additional 9 ms (or 4.5 ms in D4 framing mode) before being allowed to be updated with new signaling data.

## 10.2.2 TRANSMIT SIDE

Via the THSE control bit (CCR4.2), the framer can be set up to take the signaling data presented at the TSIG pin and insert the signaling data into the PCM data stream that is being input at the TSER pin. The user has the ability to control which channels are to have signaling data from the TSIG pin inserted into them on a channel-by-channel basis by setting the TPCSI control bit (CCR4.1) high. When TPCSI is enabled, channels in which the TCHBLK output has been programmed to be set high in, will not have signaling data from the TSIG pin inserted into them. The signaling insertion capabilities of the framer are available whether the transmit side elastic store is enabled or disabled. If the elastic store is enabled, the backplane clock (TSYSCLK) can be either 1.544 MHz or 2.048 MHz.

## 11. PER-CHANNEL CODE (IDLE) GENERATION

Data can be replaced by an idle code on a channel-by-channel basis in the transmit and receive directions. The transmit direction is from the backplane to the T1 line and is covered in Section 11.1. The receive direction is from the T1 line to the backplane and is covered in Section 11.2.

## 11.1 TRANSMIT SIDE CODE GENERATION

In the transmit direction there are two methods by which channel data from the backplane can be overwritten with data generated by the framer. The first method which is covered in Section 11.1 was a feature contained in the original DS2151 while the second method which is covered in Section 11.2 is a new feature of the DS2152/352/552.

### 11.1.1 FIXED PER-CHANNEL IDLE CODE INSERTION

The first method involves using the Transmit Idle Registers (TIR1/2/3) to determine which of the 24 T1 channels should be overwritten with the code placed in the Transmit Idle Definition Register (TIDR). This method allows the same 8-bit code to be placed into any of the 24 T1 channels. If this method is used, then the CCR4.0 control bit must be set to zero.

Each of the bit position in the Transmit Idle Registers (TIR1/TIR2/TIR3) represent a DS0 channel in the outgoing frame. When these bits are set to a one, the corresponding channel will transmit the Idle Code contained in the Transmit Idle Definition Register (TIDR). Robbed bit signaling and Bit 7 stuffing will occur over the programmed Idle Code unless the DS0 channel is made transparent by the Transmit Transparency Registers.

### TIR1/TIR2/TIR3: TRANSMIT IDLE REGISTERS (Address=3C to 3E Hex)

[Also used for Per-Channel Loopback]

(MSB)				(LSB)				
CH8	CH7	CH6	CH5	CH4	CH3	CH2	CH1	TIR1 (3C)
CH16	CH15	CH14	CH13	CH12	CH11	CH10	CH9	TIR2 (3D)
CH24	CH23	CH22	CH21	CH20	CH19	CH18	CH17	TIR3 (3E)

SYMBOLS	POSITIONS	NAME AND DESCRIPTION
CH1-24	TIR1.0-3.7	<b>Transmit Idle Code Insertion Control Bits.</b> 0 = do not insert the Idle Code in the TIDR into this channel 1 = insert the Idle Code in the TIDR into this channel

#### NOTE:

If CCR4.0=1, then a zero in the TIRs implies that channel data is to be sourced from TSER and a one implies that channel data is to be sourced from the output of the receive side framer (i.e., Per-Channel Loopback; see Figure 3-1).

### TIDR: TRANSMIT IDLE DEFINITION REGISTER (Address=3F Hex)

(MSB)							(LSB)
TIDR7	TIDR6	TIDR5	TIDR4	TIDR3	TIDR2	TIDR1	TIDR0

SYMBOL	POSITION	NAME AND DESCRIPTION
TIDR7	TIDR.7	MSB of the Idle Code (this bit is transmitted first)
TIDR0	TIDR.0	LSB of the Idle Code (this bit is transmitted last)

### 11.1.2 UNIQUE PER-CHANNEL IDLE CODE INSERTION

The second method involves using the Transmit Channel Control Registers (TCCR1/2/3) to determine which of the 24 T1 channels should be overwritten with the code placed in the Transmit Channel Registers (TC1 to TC24). This method is more flexible than the first in that it allows a different 8-bit code to be placed into each of the 24 T1 channels.

## TC1 TO TC24: TRANSMIT CHANNEL REGISTERS (Address=50 to 57 and 40 to 4F Hex)

(for brevity, only channel one is shown; see Table 5-1 for other register address)

(MSB)							(LSB)	
C7	C6	C5	C4	C3	C2	C1	C0	TC1 (50)

SYMBOL	POSITION	NAME AND DESCRIPTION
C7	TC1.7	MSB of the Code (this bit is transmitted first)
C0	TC1.0	LSB of the Code (this bit is transmitted last)

## TCC1/TCC2/TCC3: TRANSMIT CHANNEL CONTROL REGISTER (Address=16 to 18 Hex)

(MSB)								(LSB)
CH8	CH7	CH6	CH5	CH4	CH3	CH2	CH1	TCC1 (16)
CH16	CH15	CH14	CH13	CH12	CH11	CH10	CH9	TCC2 (17)
CH24	CH23	CH22	CH21	CH20	CH19	CH18	CH17	TCC3 (18)

SYMBOL	POSITION	NAME AND DESCRIPTION
CH24	TCC3.7	<b>Transmit Channel 24 Code Insertion Control Bit</b> 0=do not insert data from the TC24 register into the transmit data stream 1 = insert data from the TC24 register into the transmit data stream
CH1	TCC1.0	<b>Transmit Channel 1 Code Insertion Control Bit</b> 0=do not insert data from the TC1 register into the transmit data stream 1 = insert data from the TC1 register into the transmit data stream

## 11.2 RECEIVE SIDE CODE GENERATION

In the receive direction there are also two methods by which channel data to the backplane can be overwritten with data generated by the framer. The first method which is covered in Section 11.2.1 was a feature contained in the original DS2151 while the second method which is covered in Section 11.2.2 is a new feature of the DS2152/352/552.

## 11.2.1 FIXED PER-CHANNEL IDLE CODE INSERTION

The first method on the receive side involves using the Receive Mark Registers (RMR1/2/3) to determine which of the 24 T1 channels should be overwritten with either a 7Fh idle code or with a digital milliwatt pattern. The RCR2.7 bit will determine which code is used. The digital milliwatt code is an eight byte repeating pattern that represents a 1 kHz sine wave (1E/0B/0B/1E/9E/8B/8B/9E). Each bit in the RMRs, represents a particular channel. If a bit is set to a one, then the receive data in that channel will be replaced with one of the two codes. If a bit is set to zero, no replacement occurs.

### RMR1/RMR2/RMR3: RECEIVE MARK REGISTERS (Address=2D to 2F Hex)

(MSB)				(LSB)				
CH8	CH7	CH6	CH5	CH4	CH3	CH2	CH1	RMR1(2D)
CH16	CH15	CH14	CH13	CH12	CH11	CH10	CH9	RMR2(2E)
CH24	CH23	CH22	CH21	CH20	CH19	CH18	CH17	RMR3(2F)

SYMBOLS	POSITIONS	NAME AND DESCRIPTION
CH1-24	RMR1.0-3.7	<b>Receive Channel Mark Control Bits</b> 0 =do not affect the receive data associated with this channel 1 = replace the receive data associated with this channel with idle code or digital milliwatt code (depends on the RCR2.7 bit)

## 11.2.2 UNIQUE PER-CHANNEL CODE INSERTION

The second method involves using the Receive Channel Control Registers (RCC1/2/3) to determine which of the 24 T1 channels off of the T1 line and going to the backplane should be overwritten with the code placed in the Receive Channel Registers (RC1 to RC24). This method is more flexible than the first in that it allows a different 8-bit code to be placed into each of the 24 T1 channels.

### RC1 TO RC24: RECEIVE CHANNEL REGISTERS (Address=80 to 8F and 58 to 5F Hex)

(for brevity, only channel one is shown; see Table 5-1 for other register address)

(MSB)							(LSB)	
C7	C6	C5	C4	C3	C2	C1	C0	RC1 (80)

SYMBOL	POSITION	NAME AND DESCRIPTION
C7	RC1.7	MSB of the Code (this bit is sent first to the backplane)
C0	RC1.0	LSB of the Code (this bit is sent last to the backplane)

## RCC1/RCC2/RCC3: RECEIVE CHANNEL CONTROL REGISTER (ADDRESS=1B TO 1D Hex)

(MSB)				(LSB)				
CH8	CH7	CH6	CH5	CH4	CH3	CH2	CH1	RCC1 (1B)
CH16	CH15	CH14	CH13	CH12	CH11	CH10	CH9	RCC2 (1C)
CH24	CH23	CH22	CH21	CH20	CH19	CH18	CH17	RCC3 (1D)

SYMBOL	POSITION	NAME AND DESCRIPTION
CH24	RCC3.7	<b>Receive Channel 24 Code Insertion Control Bit</b> 0 = do not insert data from the RC24 register into the receive data stream 1 = insert data from the RC24 register into the receive data stream
CH1	RCC1.0	<b>Receive Channel 1 Code Insertion Control Bit</b> 0 = do not insert data from the RC1 register into the receive data stream 1 = insert data from the RC1 register into the receive data stream

## 12. PER-CHANNEL LOOPBACK

The Transmit Idle Registers (TIRs) have an alternate function that allows them to define a Per-Channel LoopBack (PCLB). If the TIRFS control bit (CCR4.0) is set to one, then the TIRs will determine which channels (if any) from the backplane should be replaced with the data from the receive side or in other words, off of the T1 line. If this mode is enabled, then transmit and receive clocks and frame syncs must be synchronized. One method to accomplish this would be to tie RCLK to TCLK and RFSYNC to TSYNC.

## 13. CLOCK BLOCKING REGISTERS

The Receive Channel Blocking Registers (RCBR1/RCBR2/RCBR3) and the Transmit Channel Blocking Registers (TCBR1/TCBR2/TCBR3) control the RCHBLK and TCHBLK pins respectively. The RCHBLK and TCHCLK pins are user programmable outputs that can be forced either high or low during individual channels. These outputs can be used to block clocks to a UART or LAPD controller in Fractional T1 or ISDN-PRI applications. When the appropriate bits are set to a one, the RCHBLK and TCHCLK pins will be held high during the entire corresponding channel time. See the timing in Section 21 for an example.

## RCBR1/RCBR2/RCBR3: RECEIVE CHANNEL BLOCKING REGISTERS (Address=6C to 6E Hex)

(MSB)				(LSB)				
CH8	CH7	CH6	CH5	CH4	CH3	CH2	CH1	RCBR1 (6C)
CH16	CH15	CH14	CH13	CH12	CH11	CH10	CH9	RCBR2 (6D)
CH24	CH23	CH22	CH21	CH20	CH19	CH18	CH17	RCBR3 (6E)

SYMBOLS	POSITIONS	NAME AND DESCRIPTION
CH1-24	RCBR1.0-3.7	<b>Receive Channel Blocking Control Bits.</b> 0 = force the RCHBLK pin to remain low during this channel time 1 = force the RCHBLK pin high during this channel time

## TCBR1/TCBR2/TCBR3: TRANSMIT CHANNEL BLOCKING REGISTERS (Address=32 to 34 Hex)

(MSB)				(LSB)				
CH8	CH7	CH6	CH5	CH4	CH3	CH2	CH1	TCBR1 (32)
CH16	CH15	CH14	CH13	CH12	CH11	CH10	CH9	TCBR2 (33)
CH24	CH23	CH22	CH21	CH20	CH19	CH18	CH17	TCBR3 (34)

SYMBOLS	POSITIONS	NAME AND DESCRIPTION
CH1-24	TCBR1.0-3.7	<b>Transmit Channel Blocking Control Bits.</b>

0 = force the TCHBLK pin to remain low during this channel time  
1 = force the TCHBLK pin high during this channel time

## 14. ELASTIC STORES OPERATION

The device contains dual two-frame (386 bits) elastic stores, one for the receive direction, and one for the transmit direction. These elastic stores have two main purposes. First, they can be used to rate convert the T1 data stream to 2.048 Mbps (or a multiple of 2.048 Mbps) which is the E1 rate. Secondly, they can be used to absorb the differences in frequency and phase between the T1 data stream and an asynchronous (i.e., not locked) backplane clock (which can be 1.544 MHz or 2.048 MHz). The backplane clock (TSYSCLK and/or RSYSCLK) can burst at rates up to 8.192 MHz. Both elastic stores contain full controlled slip capability which is necessary for this second purpose. The receive side elastic store can be enabled via CCR1.2 and the transmit side elastic store is enabled via CCR1.7. Both elastic stores are fully independent and no restrictions apply to the sourcing of the various clocks that are applied to them. The transmit side elastic store can be enabled whether the receive elastic store is enabled or disabled and vice versa. Also, each elastic store can interface to either a 1.544 MHz or 2.048 MHz backplane without regard to the backplane rate the other elastic store is interfacing.

### 14.1 RECEIVE SIDE

If the receive side elastic store is enabled (CCR1.2=1), then the user must provide either a 1.544 MHz (CCR1.3=0) or 2.048 MHz (CCR1.3=1) clock at the RSYSCLK pin. The user has the option of either providing a frame/multiframe sync at the RSYNC pin (RCR2.3=1) or having the RSYNC pin provide a pulse on frame boundaries (RCR2.3=0). If the user wishes to obtain pulses at the frame boundary, then RCR2.4 must be set to zero and if the user wishes to have pulses occur at the multiframe boundary, then RCR2.4 must be set to one. The framer will always indicate frame boundaries via the RFSYNC output whether the elastic store is enabled or not. If the elastic store is enabled, then multiframe boundaries will be indicated via the RMSYNC output. If the user selects to apply a 2.048 MHz clock to the RSYSCLK pin, then the data output at RSER will be forced to all ones every fourth channel and the F-bit will be passed into the MSB of TS0. Hence channels 1(bits 1-7), 5, 9, 13, 17, 21, 25, and 29 (timeslots 0(bits 1-7), 4, 8, 12, 16, 20, 24, and 28) will be forced to a one. Also, in 2.048 MHz applications, the RCHBLK output will be forced high during the same channels as the RSER pin. See Section 13 for more details. This is useful in T1 to CEPT (E1) conversion applications. If the 386-bit elastic buffer either fills or empties, a controlled slip will occur. If the buffer empties, then a full frame of data (193 bits) will be repeated at RSER and the SR1.4 and RIR1.3 bits will be set to a one. If the buffer fills, then a full frame of data will be deleted and the SR1.4 and RIR1.4 bits will be set to a one.



## 14.2 TRANSMIT SIDE

The operation of the transmit elastic store is very similar to the receive side. The transmit side elastic store is enabled via CCR1.7. A 1.544 MHz (CCR1.4=0) or 2.048 MHz (CCR1.4=1) clock can be applied to the TSYSClk input. If the user selects to apply a 2.048 MHz clock to the TSYSClk pin, then the data input at TSER will be ignored every fourth channel. Hence channels 1, 5, 9, 13, 17, 21, 25, and 29 (timeslots 0, 4, 8, 12, 16, 20, 24, and 28) will be ignored. The user must supply an 8 kHz frame sync pulse to the TSSync input. Also, in 2.048 MHz applications, the TCHBLK output will be forced high during the channels ignored by the framer. See Section 21 for more details. Controlled slips in the transmit elastic store are reported in the RIR2.3 bit and the direction of the slip is reported in the RIR2.5 and RIR2.4 bits.

## 14.3 ELASTIC STORES INITIALIZATION

There are two elastic store initializations that may be used to improve performance in certain applications, Elastic Store Reset and Elastic Store Align. Both of these involve the manipulation of the elastic store's read and write pointers and are useful primarily in synchronous applications (RSYSCLK / TSYSClk are locked to RCLK / TCLK respectively). See table below for details.

**Table 14-1 ELASTIC STORE DELAY AFTER INITIALIZATION**

Initialization	Register. Bit	Delay
Receive Elastic Store Reset	CCR7.5	8 Clocks < Delay < 1 Frame
Transmit Elastic Store Reset	CCR7.4	1 Frame < Delay < 2 Frames
Receive Elastic Store Align	CCR6.6	½ Frame < Delay < 1 ½ Frames
Transmit Elastic Store Align	CCR6.5	½ Frame < Delay < 1 ½ Frames

## 14.4 MINIMUM DELAY MODE

Elastic store minimum delay mode may be used when the elastic store's system clock is locked to its network clock (i.e., RCLK locked to RSYSCLK for the receive side and TCLK locked to TSYSClk for the transmit side). CCR3.7 and CCR3.0 enable the transmit and receive elastic store minimum delay modes. When enabled the elastic stores will be forced to a maximum depth of 32 bits instead of the normal 386 bits. This feature is useful primarily in applications that interface to a 2.048MHz bus. Certain restrictions apply when minimum delay mode is used. In addition to the restriction mentioned above, RSYNC must be configured as an output when the receive elastic store is in minimum delay mode and TSYNC must be configured as an output when transmit minimum delay mode is enabled. In a typical application RSYSCLK and TSYSClk are locked to RCLK, and RSYNC (frame output mode) is connected to TSSync (frame input mode). All of the slip contention logic in the framer is disabled (since slips cannot occur). On power-up after the RSYSCLK and TSYSClk signals have locked to their respective network clock signals, the elastic store reset bits (CCR7.4 and CCR7.5) should be toggled from a zero to a one to insure proper operation.

**Table 14-2 MINIMUM DELAY MODE CONFIGURATION**

	Hardware Requirements	Register Settings
<b>Transmit</b>	TSYSCLK can be 1.544MHz or 2.048MHz and must be locked to TCLK (1.544MHz). TSYNC is an output	CCR3.0 = 1, CCR1.7 = 1 TCR2.2 = 1
<b>Receive</b>	RSYSCLK can be 1.544MHz or 2.048MHz and must be locked to RCLK (1.544MHz). RSYNC is an output.	CCR3.7 = 1, CCR1.2 = 1 RCR2.3 = 0

## 15. HDLC CONTROLLER

This device has an enhanced HDLC controller configurable for use with the Facilities Data Link or DS0s. There are 64 byte buffers in the transmit and receive paths. The user can select any DS0 or multiple DS0s as well as any specific bits within the DS0(s) to pass through the HDLC controller. Note that

TBOC.6 = 1 and TDC1.7 = 1 cannot exist without corrupting the data in the FDL. See Table 15-1 for configuring the transmit HDLC controller.

**Table 15-1 TRANSMIT HDLC CONFIGURATION**

Function	TBOC.6	TDC1.7	TCR1.2
DS0(s)	0	1	1 or 0
FDL	1	0	1
Disable	0	0	1 or 0

Note that the BOC controller is functional when the HDLC controller is used for DS0s. Section 15.3 contains all of the HDLC and BOC registers and information on FDL/Fs Extraction and Insertion with and without the HDLC controller.

## 15.1 HDLC FORr DS0s

When using the HDLC controllers for DS0s, the same registers shown in section 15.3.2 will be used except for the TBOC and RBOC registers and bits HDLC.7, HSR.7, and HIMR.7. As a basic guideline for interpreting and sending HDLC messages and BOC messages, the following sequences can be applied.

### 15.1.1 RECEIVE AN HDLC MESSAGE

1. Enable RPS interrupts.
2. Wait for interrupt to occur.
3. Disable RPS interrupt and enable either RPE, RNE, or RHALF interrupt.
4. Read RHIR to obtain REMPTY status.
  - a. If REMPTY=0, then record OBYTE, CBYTE, and POK bits and then read the FIFO.
    - a1. If CBYTE=0 then skip to step 5.
    - a2. If CBYTE=1 then skip to step 7.
  - b. If REMPTY=1, then skip to step 6.
5. Repeat step 4.
6. Wait for interrupt, skip to step 4.
7. If POK=0, then discard whole packet, if POK=1, accept the packet.
8. Disable RPE, RNE, or RHALF interrupt, enable RPS interrupt and return to step 1.

### 15.1.2 TRANSMIT AN HDLC MESSAGE

1. Make sure HDLC controller is done sending any previous messages and is current sending flags by checking that the FIFO is empty by reading the TEMPTY status bit in the THIR register.
2. Enable either the THALF or TNF interrupt.
3. Read THIR to obtain TFULL status.
  - a. If TFULL=0, then write a byte into the FIFO and skip to next step (special case occurs when the last byte is to be written, in this case set TEOM=1 before writing the byte and then skip to step 6).
  - b. If TFULL=1, then skip to step 5.
4. Repeat step 3.
5. Wait for interrupt, skip to step 3.
6. Disable THALF or TNF interrupt and enable TMEND interrupt.
7. Wait for an interrupt, then read TUDR status bit to make sure packet was transmitted correctly.

## 15.2 FDL/Fs EXTRACTION AND INSERTION

The device has the ability to extract/insert data from/ into the Facility Data Link (FDL) in the ESF framing mode and from/into Fs-bit position in the D4 framing mode. Since SLC-96 utilizes the Fs-bit position, this capability can also be used in SLC-96 applications. The device contains a complete HDLC and BOC controller which can be used for the FDL or for DS0s. Using the HDLC controller for the FDL is covered in Section 15.3.3. To allow for backward compatibility with earlier devices, legacy functionality is maintained for the FDL, which is covered in Section 15.4. Section 15.5 covers D4 and SLC-96 operation.

Firmware, which can be retrieved from the Web site ([www.dalsemi.com/Prod\\_info/Telecom/t1\\_e1\\_tools.html](http://www.dalsemi.com/Prod_info/Telecom/t1_e1_tools.html)), was developed to implement the FDL. The code for the DS2151 incorporates the LAPD protocol and can be used with any of the 51/52/352/552 SCTs. The code for the DS2152 can be used with the 52/352/552 SCTs.

## **15.3 HDLC AND BOC CONTROLLER FOR THE FDL**

### **15.3.1 GENERAL OVERVIEW**

The device contains a complete HDLC controller with 64-byte buffers in both the transmit and receive directions as well as separate dedicated hardware for Bit Oriented Codes (BOC). The HDLC controller performs all the necessary overhead for generating and receiving Performance Report Messages (PRM) as described in ANSI T1.403 and the messages as described in AT&T TR54016. The HDLC controller automatically generates and detects flags, generates and checks the CRC check sum, generates and detects abort sequences, stuffs and destuffs zeros (for transparency), and byte aligns to the FDL data stream. The 64-byte buffers in the HDLC controller are large enough to allow a full PRM to be received or transmitted without host intervention. The BOC controller will automatically detect incoming BOC sequences and alert the host. When the BOC ceases, the device will also alert the host. The user can set the device up to send any of the possible 6-bit BOC codes.

There are thirteen registers that the host will use to operate and control the operation of the HDLC and BOC controllers. A brief description of the registers is shown in Table 15-2.

**Table 15-2 HDLC/BOC CONTROLLER REGISTERS**

NAME	FUNCTION
HDLC Control Register (HCR)	general control over the HDLC and BOC controllers
HDLC Status Register (HSR)	key status information for both transmit and receive directions
HDLC Interrupt Mask Register (HIMR)	allows/stops status bits to/from causing an interrupt
Receive HDLC Register (RHIR)	status information on receive HDLC controller
Receive BOC Register (RBOC)	status information on receive BOC controller
Receive HDLC FIFO Register (RHFR)	access to 64-byte HDLC FIFO in receive direction
Receive HDLC DS0 Control Register 1 (RDC1)	controls the HDLC function when used on DS0 channels
Receive HDLC DS0 Control Register 2 (RDC2)	controls the HDLC function when used on DS0 channels
Transmit HDLC Register (THIR)	status information on transmit HDLC controller
Transmit BOC Register (TBOC)	enables/disables transmission of BOC codes
Transmit HDLC FIFO Register (THFR)	access to 64-byte HDLC FIFO in transmit direction
Transmit HDLC DS0 Control Register 1 (TDC1)	controls the HDLC function when used on DS0 channels
Transmit HDLC DS0 Control Register 2 (TDC2)	controls the HDLC function when used on DS0 channels

### 15.3.2 STATUS REGISTER FOR THE HDLC

Four of the HDLC/BOC controller registers (HSR, RHIR, RBOC, and THIR) provide status information. When a particular event has occurred (or is occurring), the appropriate bit in one of these four registers will be set to a one. Some of the bits in these four HDLC status registers are latched and some are real time bits that are not latched. Section 15.3.2 contains register descriptions that list which bits are latched and which are not. With the latched bits, when an event occurs and a bit is set to a one, it will remain set until the user reads that bit. The bit will be cleared when it is read and it will not be set again until the event has occurred again. The real time bits report the current instantaneous conditions that are occurring and the history of these bits is not latched.

Like the other status registers, the user will always proceed a read of any of the four registers with a write. The byte written to the register will inform the device which of the latched bits the user wishes to read and have cleared (the real time bits are not affected by writing to the status register). The user will write a byte to one of these registers, with a one in the bit positions he or she wishes to read and a zero in the bit positions he or she does not wish to obtain the latest information on. When a one is written to a bit location, the read register will be updated with current value and it will be cleared. When a zero is written to a bit position, the read register will not be updated and the previous value will be held. A write to the status and information registers will be immediately followed by a read of the same register. The read result should be logically AND'ed with the mask byte that was just written and this value should be written back into the same register to insure that bit does indeed clear. This second write step is necessary because the alarms and events in the status registers occur asynchronously in respect to their access via the parallel port. This write-read-write (for polled driven access) or write-read (for interrupt driven access) scheme allows an external microcontroller or microprocessor to individually poll certain bits without disturbing the other bits in the register. This operation is key in controlling the device with higher-order software languages.

Like the SR1 and SR2 status registers, the HSR register has the unique ability to initiate a hardware interrupt via the INT\* output pin. Each of the events in the HSR can be either masked or unmasked from the interrupt pin via the HDLC Interrupt Mask Register (HIMR). Interrupts will force the INT\* pin low when the event occurs. The INT pin will be allowed to return high (if no other interrupts are present) when the user reads the event bit that caused the interrupt to occur.

### 15.3.3 BASIC OPERATION DETAILS

To allow the framer to properly source/receive data from/to the HDLC and BOC controller the legacy FDL circuitry (which is described in Section 15.4) should be disabled and the following bits should be programmed as shown:

TCR1.2 = 1 (source FDL data from the HDLC and BOC controller)  
 TBOC.6 = 1 (enable HDLC and BOC controller)  
 CCR2.5 = 0 (disable SLC-96 and D4 Fs-bit insertion)  
 CCR2.4 = 0 (disable legacy FDL zero stuffer)  
 CCR2.1 = 0 (disable SLC-96 reception)  
 CCR2.0 = 0 (disable legacy FDL zero stuffer)  
 IMR2.4 = 0 (disable legacy receive FDL buffer full interrupt)  
 IMR2.3 = 0 (disable legacy transmit FDL buffer empty interrupt)  
 IMR2.2 = 0 (disable legacy FDL match interrupt)  
 IMR2.1 = 0 (disable legacy FDL abort interrupt).

As a basic guideline for interpreting and sending both HDLC messages and BOC messages, the following sequences can be applied:

#### 15.3.3.1 RECEIVE AN HDLC MESSAGE OR A BOC

- 1) Enable RBOC and RPS interrupts.
- 2) Wait for interrupt to occur.
- 3) If RBOC=1, then follow steps 5 and 6.
- 4) If RPS=1, then follow steps 7 through 13.
- 5) If LBD=1, a BOC is present, then read the code from the RBOC register and take action as needed.
- 6) If BD=0, a BOC has ceased, take action as needed and then return to step 1.
- 7) Disable RPS interrupt and enable either RPE, RNE, or RHALF interrupt.
- 8) Read RHIR to obtain EMPTY status.
  - a) If EMPTY=0, then record OBYTE, CBYTE, and POK bits and then read the FIFO.
    - i) If CBYTE=0 then skip to step 9.
    - ii) If CBYTE=1 then skip to step 11.
  - b) If EMPTY=1, then skip to step 10.
- 9) Repeat step 8.
- 10) Wait for interrupt, skip to step 8.
- 11) If POK=0, then discard whole packet.
- 12) If POK=1, accept the packet.
- 13) Disable RPE, RNE, or RHALF interrupt, enable RPS interrupt and return to step 1.

### 15.3.3.2 TRANSMIT AN HDLC MESSAGE

- 1) Make sure HDLC controller is done sending any previous messages and is current sending flags by checking that the FIFO is empty by reading the EMPTY status bit in the TPRM register.
- 2) Enable either the THALF or TNF interrupt.
- 3) Read THIR to obtain TFULL status.
  - a) If TFULL=0, then write a byte into the FIFO and skip to next step (special case occurs when the last byte is to be written, in this case set TEOM=1 before writing the byte and then skip to step 6).
  - b) If TFULL=1, then skip to step 5.
- 4) Repeat step 3.
- 5) Wait for interrupt, skip to step 3.
- 6) Disable THALF or TNF interrupt and enable TMEND interrupt.
- 7) Wait for an interrupt, then read TUDR status bit to make sure packet was transmitted correctly.

### 15.3.3.3 TRANSMIT A BOC

- 1) Write 6-bit code into TBOC.
- 2) Set SBOC bit in TBOC=1.

## 15.3.4 HDLC/BOC Register Description

### HCR: HDLC CONTROL REGISTER (Address=00 Hex)

(MSB)						(LSB)	
RBR	RHR	TFS	THR	TABT	TEOM	TZSD	TCRCD

SYMBOL	POSITION	NAME AND DESCRIPTION
RBR	HCR.7	<b>Receive BOC Reset.</b> A 0 to 1 transition will reset the BOC circuitry. Must be cleared and set again for a subsequent reset.
RHR	HCR.6	<b>Receive HDLC Reset.</b> A 0 to 1 transition will reset the HDLC controller. Must be cleared and set again for a subsequent reset.
TFS	HCR.5	<b>Transmit Flag/Idle Select.</b> 0 = 7Eh 1 = FFh
THR	HCR.4	<b>Transmit HDLC Reset.</b> A 0 to 1 transition will reset both the HDLC controller and the transmit BOC circuitry. Must be cleared and set again for a subsequent reset.
TABT	HCR.3	<b>Transmit Abort.</b> A 0 to 1 transition will cause the FIFO contents to be dumped and one FEh abort to be sent followed by 7Eh or FFh flags/idle until a new packet is initiated by writing new data into the FIFO. Must be cleared and set again for a subsequent abort to be sent.
TEOM	HCR.2	<b>Transmit End of Message.</b> Should be set to a one just before the last data byte of a HDLC packet is written into the transmit FIFO at TFFR. This bit will be cleared by the HDLC controller when the last byte has been transmitted.
TZSD	HCR.1	<b>Transmit Zero Stuffer Defeat.</b> Overrides internal enable. 0 = enable the zero stuffer (normal operation) 1 = disable the zero stuffer
TCRCD	HCR.0	<b>Transmit CRC Defeat.</b> 0 = enable CRC generation (normal operation) 1 = disable CRC generation

### HSR: HDLC STATUS REGISTER (Address=01 Hex)

(MSB)						(LSB)	
RBOC	RPE	RPS	RHALF	RNE	THALF	TNF	TMEND

SYMBOL	POSITION	NAME AND DESCRIPTION
RBOC	HSR.7	<b>Receive BOC Detector Change of State.</b> Set whenever the BOC detector sees a change of state from a BOC Detected to a No Valid Code seen or vice versa. The setting of this bit prompt the user to read the RBOC register for details.

RPE	HSR.6	<b>Receive Packet End.</b> Set when the HDLC controller detects either the finish of a valid message (i.e., CRC check complete) or when the controller has experienced a message fault such as a CRC checking error, or an overrun condition, or an abort has been seen. The setting of this bit prompts the user to read the RPRM register for details.
RPS	HSR.5	<b>Receive Packet Start.</b> Set when the HDLC controller detects an opening byte. The setting of this bit prompts the user to read the RPRM register for details.
RHALF	HSR.4	<b>Receive FIFO Half Full.</b> Set when the receive 64-byte FIFO fills beyond the half way point. The setting of this bit prompts the user to read the RPRM register for details.
RNE	HSR.3	<b>Receive FIFO Not Empty.</b> Set when the receive 64-byte FIFO has at least one byte available for a read. The setting of this bit prompts the user to read the RPRM register for details.
THALF	HSR.2	<b>Transmit FIFO Half Empty.</b> Set when the transmit 64-byte FIFO empties beyond the half way point. The setting of this bit prompts the user to read the TPRM register for details.
TNF	HSR.1	<b>Transmit FIFO Not Full.</b> Set when the transmit 64-byte FIFO has at least one byte available. The setting of this bit prompts the user to read the TPRM register for details.
TMEND	HSR.0	<b>Transmit Message End.</b> Set when the transmit HDLC controller has finished sending a message. The setting of this bit prompts the user to read the TPRM register for details.

**NOTE:**

The RBOC, RPE, RPS, and TMEND bits are latched and will be cleared when read.

**HIMR: HDLC INTERRUPT MASK REGISTER (Address=02 Hex)**

(MSB)						(LSB)	
RBOC	RPE	RPS	RHALF	RNE	THALF	TNF	TMEND

SYMBOL	POSITION	NAME AND DESCRIPTION
RBOC	HIMR.7	<b>Receive BOC Detector Change of State.</b> 0 = interrupt masked 1 = interrupt enabled
RPE	HIMR.6	<b>Receive Packet End.</b> 0 = interrupt masked 1 = interrupt enabled
RPS	HIMR.5	<b>Receive Packet Start.</b> 0 = interrupt masked 1 = interrupt enabled
RHALF	HIMR.4	<b>Receive FIFO Half Full.</b> 0 = interrupt masked 1 = interrupt enabled
RNE	HIMR.3	<b>Receive FIFO Not Empty.</b> 0 = interrupt masked 1 = interrupt enabled
THALF	HIMR.2	<b>Transmit FIFO Half Empty.</b> 0 = interrupt masked 1 = interrupt enabled
TNF	HIMR.1	<b>Transmit FIFO Not Full.</b> 0 = interrupt masked 1 = interrupt enabled
TMEND	FIMR.0	<b>Transmit Message End.</b> 0 = interrupt masked 1 = interrupt enabled



**RHIR: RECEIVE HDLC INFORMATION REGISTER (Address=03 Hex)**

(MSB)				(LSB)			
RABT	RCRCE	ROVR	RVM	EMPTY	POK	CBYTE	OBYTE

SYMBOL	POSITION	NAME AND DESCRIPTION
RABT	RHIR.7	<b>Abort Sequence Detected.</b> Set whenever the HDLC controller sees 7 or more ones in a row.
RCRCE	RHIR.6	<b>CRC Error.</b> Set when the CRC checksum is in error.
ROVR	RHIR.5	<b>Overrun.</b> Set when the HDLC controller has attempted to write a byte into an already full receive FIFO.
RVM	RHIR.4	<b>Valid Message.</b> Set when the HDLC controller has detected and checked a complete HDLC packet.
EMPTY	RHIR.3	<b>Empty.</b> A real-time bit that is set high when the receive FIFO is empty.
POK	RHIR.2	<b>Packet OK.</b> Set when the byte available for reading in the receive FIFO is the last byte of a valid message (and hence no abort was seen, no overrun occurred, and the CRC was correct).
CBYTE	RHIR.1	<b>Closing Byte.</b> Set when the byte available for reading in the receive FIFO is the last byte of a message (whether the message was valid or not).
OBYTE	RHIR.0	<b>Opening Byte.</b> Set when the byte available for reading in the receive FIFO is the first byte of a message.

**NOTE:**

The RABT, RCRCE, ROVR, and RVM bits are latched and will be cleared when read.

**RBOC: RECEIVE BIT ORIENTED CODE REGISTER (Address=04 Hex)**

(MSB)							(LSB)
LBD	BD	BOC5	BOC4	BOC3	BOC2	BOC1	BOC0

SYMBOL	POSITION	NAME AND DESCRIPTION
LBD	RBOC.7	<b>Latched BOC Detected.</b> A latched version of the BD status bit (RBOC.6). Will be cleared when read.
BD	RBOC.6	<b>BOC Detected.</b> A real-time bit that is set high when the BOC detector is presently seeing a valid sequence and set low when no BOC is currently being detected.
BOC5	RBOC.5	<b>BOC Bit 5.</b> Last bit received of the 6-bit codeword.
BOC4	RBOC.4	<b>BOC Bit 4.</b>
BOC3	RBOC.3	<b>BOC Bit 3.</b>
BOC2	RBOC.2	<b>BOC Bit 2.</b>
BOC1	RBOC.1	<b>BOC Bit 1.</b>
BOC0	RBOC.0	<b>BOC Bit 0.</b> First bit received of the 6-bit codeword.

**NOTE:**

1. The LBD bit is latched and will be cleared when read.
2. The RBOC0 to RBOC5 bits display the last valid BOC code verified; these bits will be set to all ones on reset.

**RHFR: RECEIVE HDLC FIFO (Address=05 Hex)**

(MSB)						(LSB)	
RHFR7	RHFR6	RHFR5	RHFR4	RHFR3	RHFR2	RHFR1	RHFR0
SYMBOL	POSITION	NAME AND DESCRIPTION					
RHFR7	RHFR.7	<b>HDLC Data Bit 7.</b> MSB of a HDLC packet data byte.					
RHFR6	RHFR.6	<b>HDLC Data Bit 6.</b>					
RHFR5	RHFR.5	<b>HDLC Data Bit 5.</b>					
RHFR4	RHFR.4	<b>HDLC Data Bit 4.</b>					
RHFR3	RHFR.3	<b>HDLC Data Bit 3.</b>					
RHFR2	RHFR.2	<b>HDLC Data Bit 2.</b>					
RHFR1	RHFR.1	<b>HDLC Data Bit 1.</b>					
RHFR0	RHFR.0	<b>HDLC Data Bit 0.</b> LSB of a HDLC packet data byte.					

**THIR: TRANSMIT HDLC INFORMATION (Address=06 Hex)**

(MSB)						(LSB)	
–	–	–	–	–	EMPTY	TFULL	TUDR
SYMBOL	POSITION	NAME AND DESCRIPTION					
–	THIR.7	<b>Not Assigned.</b> Could be any value when read.					
–	THIR.6	<b>Not Assigned.</b> Could be any value when read.					
–	THIR.5	<b>Not Assigned.</b> Could be any value when read.					
–	THIR.4	<b>Not Assigned.</b> Could be any value when read.					
–	THIR.3	<b>Not Assigned.</b> Could be any value when read.					
EMPTY	THIR.2	<b>Transmit FIFO Empty.</b> A real-time bit that is set high when the FIFO is empty.					
TFULL	THIR.1	<b>Transmit FIFO Full.</b> A real-time bit that is set high when the FIFO is full.					
TUDR	THIR.0	<b>Transmit FIFO Under-run.</b> Set when the transmit FIFO empties out without the TEOM control bit being set. An abort is automatically sent.					

**NOTE:**

The TUDR bit is latched and will be cleared when read.

**TBOC: TRANSMIT BOC REGISTER (Address=07 Hex)**

(MSB)						(LSB)	
SBOC	HBEN	BOC5	BOC4	BOC3	BOC2	BOC1	BOC0
SYMBOL	POSITION	NAME AND DESCRIPTION					
SBOC	TBOC.7	<b>Send BOC.</b> Rising edge triggered. Must be transitioned from a 0 to a 1 to transmit the BOC code placed in the BOC0 to BOC5 bits instead of data from the HDLC controller.					
HBEN	TBOC.6	<b>Transmit HDLC &amp; BOC Controller Enable.</b>					

		0 = source FDL data from the TLINK pin 1 = source FDL data from the onboard HDLC and BOC controller
BOC5	TBOC.5	<b>BOC Bit 5.</b> Last bit transmitted of the 6-bit codeword.
BOC4	TBOC.4	<b>BOC Bit 4.</b>
BOC3	TBOC.3	<b>BOC Bit 3.</b>
BOC2	TBOC.2	<b>BOC Bit 2.</b>
BOC1	TBOC.1	<b>BOC Bit 1.</b>
BOC0	TBOC.0	<b>BOC Bit 0.</b> First bit transmitted of the 6-bit codeword.

## THFR: TRANSMIT HDLC FIFO (Address=08 Hex)

<b>(MSB)</b>						<b>(LSB)</b>	
THFR7	THFR6	THFR5	THFR4	THFR3	THFR2	THFR1	THFR0

SYMBOL	POSITION	NAME AND DESCRIPTION
THFR7	THFR.7	<b>HDLC Data Bit 7.</b> MSB of a HDLC packet data byte.
THFR6	THFR.6	<b>HDLC Data Bit 6.</b>
THFR5	THFR.5	<b>HDLC Data Bit 5.</b>
THFR4	THFR.4	<b>HDLC Data Bit 4.</b>
THFR3	THFR.3	<b>HDLC Data Bit 3.</b>
THFR2	THFR.2	<b>HDLC Data Bit 2.</b>
THFR1	THFR.1	<b>HDLC Data Bit 1.</b>
THFR0	THFR.0	<b>HDLC Data Bit 0.</b> LSB of a HDLC packet data byte.

## RDC1: RECEIVE HDLC DS0 CONTROL REGISTER 1 (Address=90 Hex)

<b>(MSB)</b>						<b>(LSB)</b>	
RDS0E	-	RDS0M	RD4	RD3	RD2	RD1	RD0

SYMBOL	POSITION	NAME AND DESCRIPTION
RDS0E	RDC1.7	<b>HDLC DS0 Enable.</b> 0 = use the receive HDLC controller for the FDL. 1 = use the receive HDLC controller for one or more DS0 channels.
-	RDC1.6	<b>Not Assigned.</b> Should be set to 0.
RDS0M	RDC1.5	<b>DS0 Selection Mode.</b> 0 = utilize the RD0 to RD4 bits to select which single DS0 channel to use. 1 = utilize the RCHBLK control registers to select which DS0 channels to use.
RD4	RDC1.4	<b>DS0 Channel Select Bit 4.</b> MSB of the DS0 channel select.
RD3	RDC1.3	<b>DS0 Channel Select Bit 3.</b>
RD2	RDC1.2	<b>DS0 Channel Select Bit 2.</b>

---

RD1	RDC1.1	<b>DS0 Channel Select Bit 1.</b>
RD0	RDC1.0	<b>DS0 Channel Select Bit 0.</b> LSB of the DS0 channel select.

**RDC2: RECEIVE HDLC DS0 CONTROL REGISTER 2 (Address=91 Hex)**

(MSB)							(LSB)
RDB8	RDB7	RDB6	RDB5	RDB4	RDB3	RDB2	RDB1

SYMBOL	POSITION	NAME AND DESCRIPTION
RDB8	RDC2.7	<b>DS0 Bit 8 Suppress Enable.</b> MSB of the DS0. Set to one to stop this bit from being used.
RDB7	RDC2.6	<b>DS0 Bit 7 Suppress Enable.</b> Set to one to stop this bit from being used.
RDB6	RDC2.5	<b>DS0 Bit 6 Suppress Enable.</b> Set to one to stop this bit from being used.
RDB5	RDC2.4	<b>DS0 Bit 5 Suppress Enable.</b> Set to one to stop this bit from being used.
RDB4	RDC2.3	<b>DS0 Bit 4 Suppress Enable.</b> Set to one to stop this bit from being used.
RDB3	RDC2.2	<b>DS0 Bit 3 Suppress Enable.</b> Set to one to stop this bit from being used.
RDB2	RDC2.1	<b>DS0 Bit 2 Suppress Enable.</b> Set to one to stop this bit from being used.
RDB1	RDC2.0	<b>DS0 Bit 1 Suppress Enable.</b> LSB of the DS0. Set to one to stop this bit from being used.

**TDC1: TRANSMIT HDLC DS0 CONTROL REGISTER 1 (Address=92 Hex)**

(MSB)							(LSB)
TDS0E	-	TDS0M	TD4	TD3	TD2	TD1	TD0

SYMBOL	POSITION	NAME AND DESCRIPTION
TDS0E	TDC1.7	<b>HDLC DS0 Enable.</b> 0 = use the transmit HDLC controller for the FDL. 1 = use the transmit HDLC controller for one or more DS0 channels.
-	TDC1.6	<b>Not Assigned.</b> Should be set to 0.
TDS0M	TDC1.5	<b>DS0 Selection Mode.</b> 0 = utilize the TD0 to TD4 bits to select which single DS0 channel to use. 1 = utilize the TCHBLK control registers to select which DS0 channels to use.
TD4	TDC1.4	<b>DS0 Channel Select Bit 4.</b> MSB of the DS0 channel select.
TD3	TDC1.3	<b>DS0 Channel Select Bit 3.</b>
TD2	TDC1.2	<b>DS0 Channel Select Bit 2.</b>
TD1	TDC1.1	<b>DS0 Channel Select Bit 1.</b>
TD0	TDC1.0	<b>DS0 Channel Select Bit 0.</b> LSB of the DS0 channel select.

**TDC2: TRANSMIT HDLC DS0 CONTROL REGISTER 2 (Address=93 Hex)**

(MSB)							(LSB)
TDB8	TDB7	TDB6	TDB5	TDB4	TDB3	TDB2	TDB1

SYMBOL	POSITION	NAME AND DESCRIPTION
TDB8	TDC2.7	<b>DS0 Bit 8 Suppress Enable.</b> MSB of the DS0. Set to one to stop this bit from being used.
TDB7	TDC2.6	<b>DS0 Bit 7 Suppress Enable.</b> Set to one to stop this bit from being used.
TDB6	TDC2.5	<b>DS0 Bit 6 Suppress Enable.</b> Set to one to stop this bit from being used.
TDB5	TDC2.4	<b>DS0 Bit 5 Suppress Enable.</b> Set to one to stop this bit from being used.
TDB4	TDC2.3	<b>DS0 Bit 4 Suppress Enable.</b> Set to one to stop this bit from being used.
TDB3	TDC2.2	<b>DS0 Bit 3 Suppress Enable.</b> Set to one to stop this bit from being used.
TDB2	TDC2.1	<b>DS0 Bit 2 Suppress Enable.</b> Set to one to stop this bit from being used.
TDB1	TDC2.0	<b>DS0 Bit 1 Suppress Enable.</b> LSB of the DS0. Set to one to stop this bit from being used.

**15.4 LEGACY FDL SUPPORT****15.4.1 OVERVIEW**

In order to provide backward compatibility to the older DS2152 device, the DS21352/552 maintains the circuitry that existed in the previous generation of the T1 Quad Framer. Sections 15.4.2 and 15.4.3 cover the circuitry and operation of this legacy functionality. In new applications, it is recommended that the HDLC controller and BOC controller described in Section 15.3 are used. On the receive side, it is possible to have both the new HDLC/BOC controller and the legacy hardware working at the same time. On the transmit side the HDLC/BOC controller can be assigned to a DSO while the legacy function supports the FDL via software. Software for supporting the legacy functions is available from Dallas Semiconductor.

**15.4.2 RECEIVE SECTION**

In the receive section, the recovered FDL bits or Fs bits are shifted bit-by-bit into the Receive FDL register (RFDL). Since the RFDL is 8 bits in length, it will fill up every 2 ms (8 times 250 us). The framer will signal an external microcontroller that the buffer has filled via the SR2.4 bit. If enabled via IMR2.4, the INT pin will toggle low indicating that the buffer has filled and needs to be read. The user has 2 ms to read this data before it is lost. If the byte in the RFDL matches either of the bytes programmed into the RFDLM1 or RFDLM2 registers, then the SR2.2 bit will be set to a one and the INT pin will toggled low if enabled via IMR2.2. This feature allows an external microcontroller to ignore the FDL or Fs pattern until an important event occurs.



The framer also contains a zero destuffer which is controlled via the CCR2.0 bit. In both ANSI T1.403 and TR54016, communications on the FDL follows a subset of a LAPD protocol. The LAPD protocol states that no more than 5 ones should be transmitted in a row so that the data does not resemble an opening or closing flag (01111110) or an abort signal (11111111). If enabled via CCR2.0, the DS21352/552 will automatically look for 5 ones in a row, followed by a zero. If it finds such a pattern, it will automatically remove the zero. If the zero destuffer sees six or more ones in a row followed by a zero, the zero is not removed. The CCR2.0 bit should always be set to a one when the DS21352/552 is extracting the FDL. More on how to use the DS21352/552 in FDL applications in this legacy support mode is covered in a separate Application Note.

## **RFDL: RECEIVE FDL REGISTER (Address=28 Hex)**

<b>(MSB)</b>							<b>(LSB)</b>
RFDL7	RFDL6	RFDL5	RFDL4	RFDL3	RFDL2	RFDL1	RFDL0

<b>SYMBOL</b>	<b>POSITION</b>	<b>NAME AND DESCRIPTION</b>
RFDL7	RFDL.7	MSB of the Received FDL Code
RFDL0	RFDL.0	LSB of the Received FDL Code

The Receive FDL Register (RFDL) reports the incoming Facility Data Link (FDL) or the incoming Fs bits. The LSB is received first.

## **RFDLM1: RECEIVE FDL MATCH REGISTER 1 (Address=29 Hex)** **RFDLM2: RECEIVE FDL MATCH REGISTER 2 (Address=2A Hex)**

<b>(MSB)</b>							<b>(LSB)</b>
RFDL7	RFDL6	RFDL5	RFDL4	RFDL3	RFDL2	RFDL1	RFDL0

<b>SYMBOL</b>	<b>POSITION</b>	<b>NAME AND DESCRIPTION</b>
RFDL7	RFDL.7	MSB of the FDL Match Code
RFDL0	RFDL.0	LSB of the FDL Match Code

When the byte in the Receive FDL Register matches either of the two Receive FDL Match Registers (RFDLM1/RFDLM2), SR2.2 will be set to a one and the INT will go active if enabled via IMR2.2.

### 15.4.3 TRANSMIT SECTION

The transmit section will shift out into the T1 data stream, either the FDL (in the ESF framing mode) or the Fs bits (in the D4 framing mode) contained in the Transmit FDL register (TFDL). When a new value is written to the TFDL, it will be multiplexed serially (LSB first) into the proper position in the outgoing T1 data stream. After the full eight bits has been shifted out, the framer will signal the host microcontroller that the buffer is empty and that more data is needed by setting the SR2.3 bit to a one. The INT will also toggle low if enabled via IMR2.3. The user has 2 ms to update the TFDL with a new value. If the TFDL is not updated, the old value in the TFDL will be transmitted once again. The framer also contains a zero stuffer which is controlled via the CCR2.4 bit. In both ANSI T1.403 and TR54016, communications on the FDL follows a subset of a LAPD protocol. The LAPD protocol states that no more than 5 ones should be transmitted in a row so that the data does not resemble an opening or closing flag (01111110) or an abort signal (11111111). If enabled via CCR2.4, the framer will automatically look for 5 ones in a row. If it finds such a pattern, it will automatically insert a zero after the five ones. The CCR2.0 bit should always be set to a one when the framer is inserting the FDL. More on how to use the DS21352/552 in FDL applications is covered in a separate Application Note.

### TFDL: TRANSMIT FDL REGISTER (Address=7E Hex)

[also used to insert Fs framing pattern in D4 framing mode; see Section 15.5]

(MSB)								(LSB)
TFDL7	TFDL6	TFDL5	TFDL4	TFDL3	TFDL2	TFDL1	TFDL0	

SYMBOL	POSITION	NAME AND DESCRIPTION
TFDL7	TFDL.7	MSB of the FDL code to be transmitted
TFDL0	TFDL.0	LSB of the FDL code to be transmitted

The Transmit FDL Register (TFDL) contains the Facility Data Link (FDL) information that is to be inserted on a byte basis into the outgoing T1 data stream. The LSB is transmitted first.

### 15.5 D4/SLC-96 OPERATION

In the D4 framing mode, the framer uses the TFDL register to insert the Fs framing pattern. To allow the device to properly insert the Fs framing pattern, the TFDL register at address 7Eh must be programmed to 1Ch and the following bits must be programmed as shown: TCR1.2=0 (source Fs data from the TFDL register) CCR2.5=1 (allow the TFDL register to load on multiframe boundaries)

Since the SLC-96 message fields share the Fs-bit position, the user can access these message fields via the TFDL and RFDL registers. Please see the separate Application Note for a detailed description of how to implement a SLC-96 function.

## 16. LINE INTERFACE FUNCTION

The line interface function in the DS21352/552 contains three sections; (1) the receiver which handles clock and data recovery, (2) the transmitter which waveshapes and drives the T1 line, and (3) the jitter attenuator. Each of these three sections is controlled by the Line Interface Control Register (LICR) which is described below.

### LICR: LINE INTERFACE CONTROL REGISTER (Address=7C Hex)

(MSB)								(LSB)
L2	L1	L0	EGL	JAS	JABDS	DJA	TPD	
<b>SYMBOL</b>	<b>POSITION</b>	<b>NAME AND DESCRIPTION</b>						
L2	LICR.7	Line Build Out Select Bit 2. Sets the transmitter build out; see Table 16-1						
L1	LICR.6	Line Build Out Select Bit 1. Sets the transmitter build out; see Table 16-1						
L0	LICR.5	Line Build Out Select Bit 0. Sets the transmitter build out; see Table 16-1						
EGL	LICR.4	Receive Equalizer Gain Limit. 0 = -36 dB 1 = -30 dB						
JAS	LICR.3	Jitter Attenuator Select. 0 = place the jitter attenuator on the receive side 1 = place the jitter attenuator on the transmit side						
JABDS	LICR.2	Jitter Attenuator Buffer Depth Select 0 = 128 bits 1 = 32 bits (use for delay sensitive applications)						
DJA	LICR.1	Disable Jitter Attenuator. 0 = jitter attenuator enabled 1 = jitter attenuator disabled						
TPD	LICR.0	Transmit Power Down. 0 = normal transmitter operation 1 = powers down the transmitter and 3-states the TTIP and TRING pins						

### 16.1 RECEIVE CLOCK AND DATA RECOVERY

The DS21352/552 contains a digital clock recovery system. See Figure 3-1 and Figure 16-1 for more details. The DS21352/552 couples to the receive T1 twisted pair via a 1:1 transformer. See for details. The 1.544 MHz clock applied to the MCLK pin is internally multiplied by 16 via an internal PLL and fed to the clock recovery system. The clock recovery system uses the clock from the PLL circuit to form a 16 times oversampler which is used to recover the clock and data. This oversampling technique offers outstanding jitter tolerance (see Figure 16-4).

Normally, the clock that is output at the RCLKO pin is the recovered clock from the T1 AMI/B8ZS waveform presented at the RTIP and RRING inputs. When no AMI signal is present at RTIP and RRING, a Receive Carrier Loss (LRCL) condition will occur and the RCLKO will be sourced from the clock applied at the MCLK pin. If the jitter attenuator is either placed in the transmit path or is disabled, the RCLKO output can exhibit slightly shorter high cycles of the clock. This is due to the highly oversampled digital clock recovery circuitry. If the jitter attenuator is placed in the receive path (as is the case in most applications), the jitter attenuator restores the RCLK to being close to 50% duty cycle. Please see the Receive AC Timing Characteristics in section 24 for more details.

## 16.2 TRANSMIT WAVE SHAPING AND LINE DRIVING

The DS21352/552 uses a set of laser-trimmed delay lines along with a precision Digital-to-Analog Converter (DAC) to create the waveforms that are transmitted onto the T1 line. The waveforms created by the DS21352/552 meet the latest ANSI, AT&T, and ITU specifications. See Figure 16-3. The user will select which waveform is to be generated by properly programming the L2/L1/L0 bits in the Line Interface Control Register (LICR). The DS21352/552 can set up in a number of various configurations depending on the application. See Table 16-1.

**Table 16-1 LINE BUILD OUT SELECT IN LICR**

L2	L1	L0	LINE BUILD OUT	APPLICATION
0	0	0	0 to 133 feet/	DSX-1/0dB CSU
0	0	1	133 feet to 266	DSX-1
0	1	0	266 feet to 399	DSX-1
0	1	1	399 feet to 533	DSX-1
1	0	0	533 feet to 655	DSX-1
1	0	1	-7.5 dB	CSU
1	1	0	-15 dB	CSU
1	1	1	-22.5 dB	CSU

Due to the nature of the design of the transmitter in the DS21352/552, very little jitter (less than 0.005 UIpp broad-band from 10 Hz to 100 kHz) is added to the jitter present on TCLKI. Also, the waveforms that they create are independent of the duty cycle of TCLK. The transmitter in the DS21352/552 couples to the T1 transmit twisted pair via a 1:1.15 or 1:1.36 step up transformer for the DS21552 or a 1:2 step up transformer for the DS21352 as shown in Figure 16-1. In order for the devices to create the proper waveforms, this transformer used must meet the specifications listed in Table 16-3.

## 16.3 JITTER ATTENUATOR

The DS21352/552 contains an onboard jitter attenuator that can be set to a depth of either 32 or 128 bits via the JABDS bit in the Line Interface Control Register (LICR). The 128 bit mode is used in applications where large excursions of wander are expected. The 32 bit mode is used in delay sensitive applications. The characteristics of the attenuation are shown in Figure 16-4. The jitter attenuator can be placed in either the receive or transmit path via the JAS bit in the LICR. Also, the jitter attenuator can be disabled (in effect, removed) by setting the DJA bit in the LICR. In order for the jitter attenuator to operate properly, a 1.544 MHz clock (+50 ppm) must be applied at the MCLK pin or a crystal with similar characteristics must be applied across the MCLK and XTALD pins. If a crystal is applied across the MCLK and XTALD pins, then the maximum effective series resistance (ESR) should be 40 Ohms and capacitors should be placed from each leg of the crystal to the local ground plane as shown in Figure 16-1. Onboard circuitry adjusts either the recovered clock from the clock/data recovery block or the clock applied at the TCLKI pin to create a smooth jitter free clock which is used to clock data out of the jitter attenuator FIFO. It is acceptable to provide a gapped/ bursty clock at the TCLKI pin if the jitter attenuator is placed on the transmit side. If the incoming jitter exceeds either 120 UIpp (buffer depth is 128 bits) or 28 UIpp (buffer depth is 32 bits), then the DS21352/552 will divide the internal nominal 24.704 MHz clock by either 15 or 17 instead of the normal 16 to keep the buffer from overflowing. When the device divides by either 15 or 17, it also sets the Jitter Attenuator Limit Trip (JALT) bit in the Receive Information Register (RIR3.5).

## Figure 16-1 EXTERNAL ANALOG CONNECTIONS

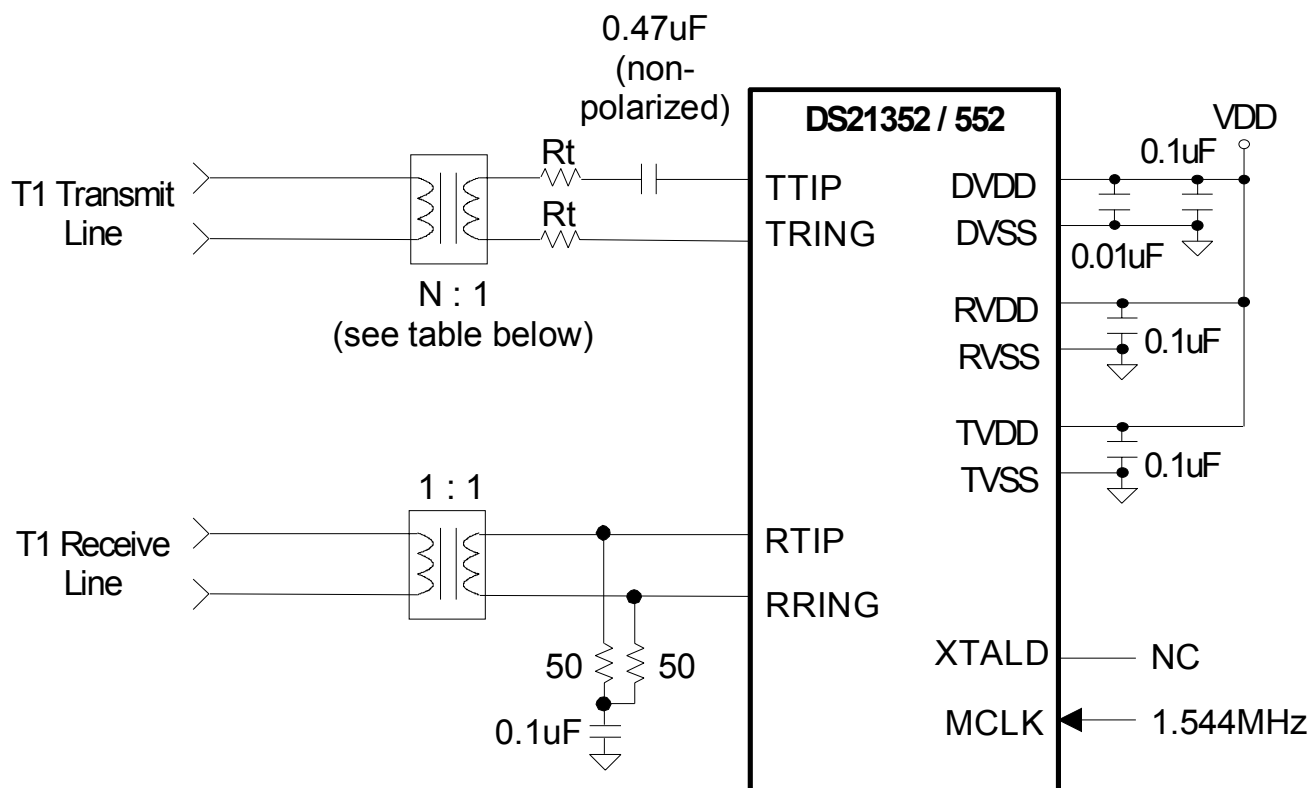

### Table 16-2 TRANSMIT TRANSFORMER SELECTION

DEVICE	TRANSFORMER	RESISTOR $R_t$
DS21552	1.15 : 1	0 ohms Ideal, 2.2 ohms max
	1.36 : 1	4.7 ohms Ideal
DS21352	2 : 1	0 ohms

See separate application note on line interface design criteria for full details.

### NOTES:

1. Resistor values are +/-1%.
2. The  $R_t$  resistors are used to protect the device from over-voltage.
3. See the Separate Application Note for details on how to construct a protected interface.
4. Normally a TTL level clock is applied MCLK and the XTAL pin is left as an NC. Optionally a crystal can be applied across the MCLK and XTALD pins.

### Table 16-3 TRANSFORMER SPECIFICATIONS

SPECIFICATION	RECOMMENDED VALUE
Turns Ratio DS21352	1:1(receive) and 1:2(transmit) 5%
Turns Ratio DS21552	1:1(receive) and 1:1.15 or 1:1.36(transmit) 5%
Primary Inductance	600 $\mu$ H minimum
Leakage Inductance	1.0 $\mu$ H maximum
Intertwining Capacitance	40 pF maximum
DC Resistance	1.2 Ohms maximum

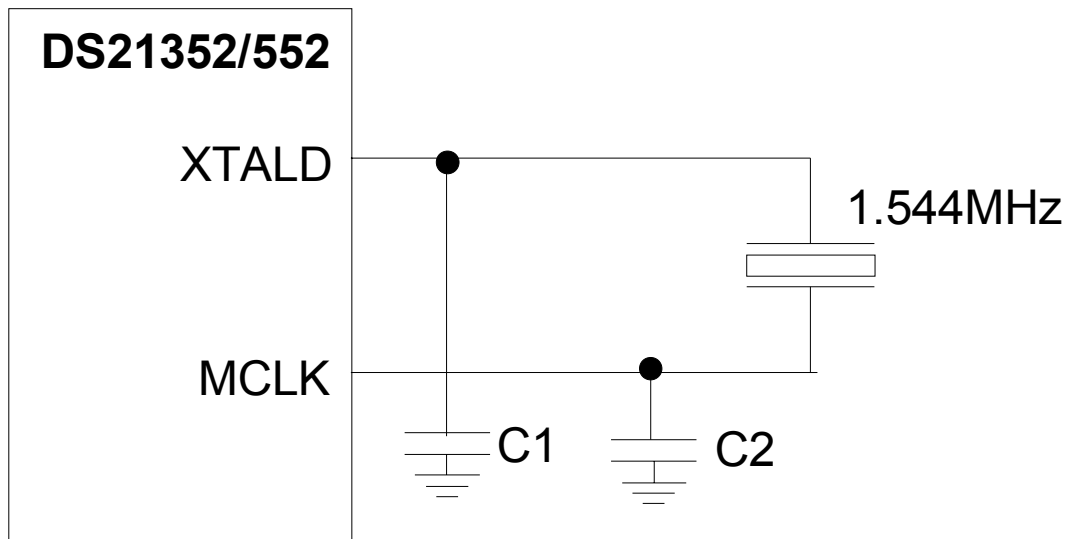
**Figure 16-2 OPTIONAL CRYSTAL CONNECTIONS****NOTES:**

1. C1 and C2 should be 5 pF lower than two times the nominal loading capacitance of the crystal to adjust for the input capacitance of the DS21352/552.

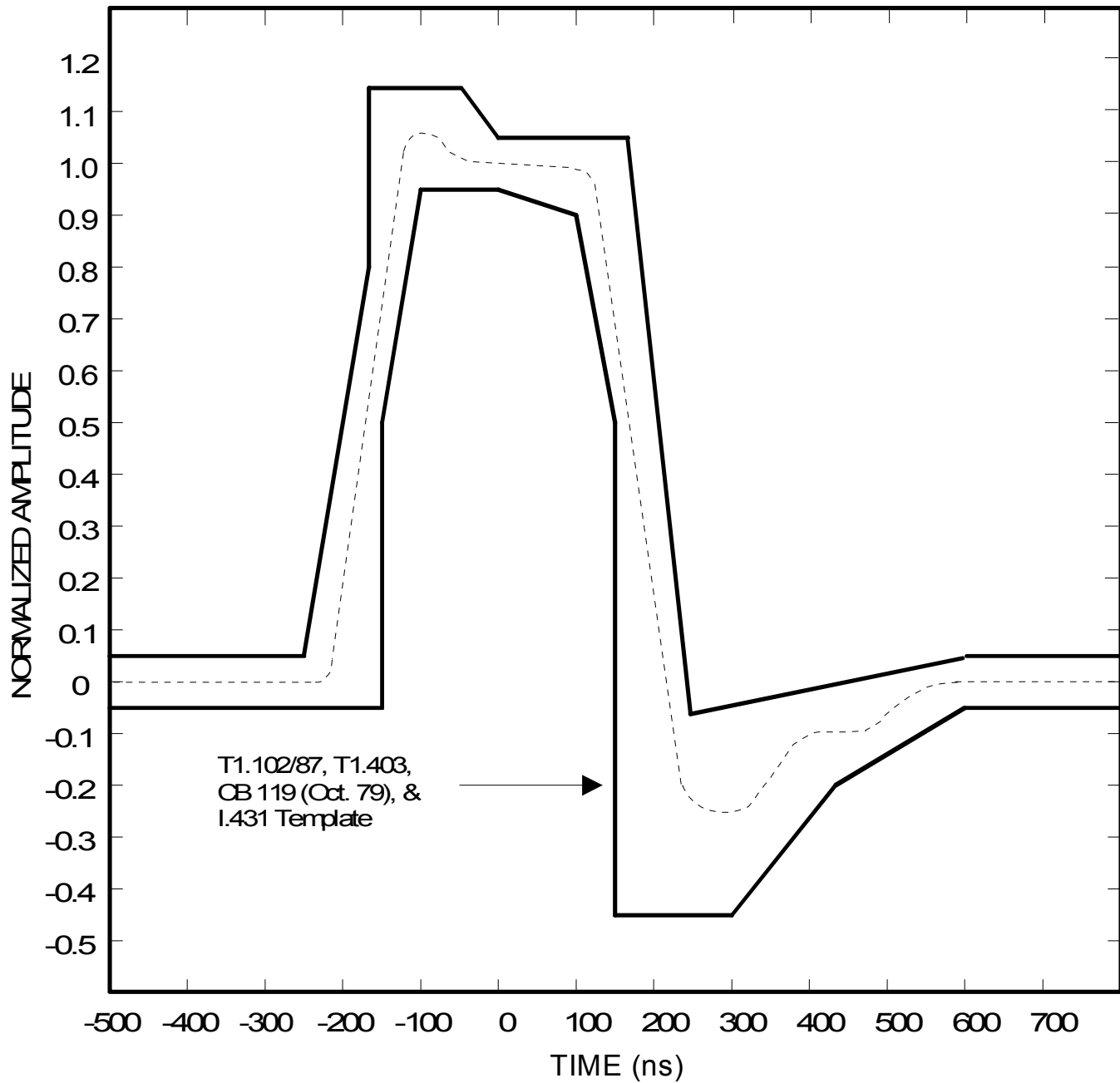
**Figure 16-3 TRANSMIT WAVEFORM TEMPLATE**

**Table 16-4 PULSE TEMPLATE CORNER POINTS**

<b>TIME (ns)</b>	<b>UI</b>	<b>MAX CURVE</b>	<b>MIN CURVE</b>
<b>-500</b>	<b>-0.77</b>	<b>0.05</b>	<b>-0.05</b>
<b>-255</b>	<b>-0.39</b>	<b>0.05</b>	
<b>-175</b>	<b>-0.27</b>	<b>0.80</b>	
<b>-175</b>	<b>-0.27</b>	<b>1.15</b>	
<b>-150</b>	<b>-0.23</b>		<b>-0.05</b>
<b>-150</b>	<b>-0.23</b>		<b>0.05</b>
<b>-100</b>			<b>0.95</b>
<b>-75</b>	<b>-0.12</b>	<b>1.15</b>	
<b>0</b>	<b>0.00</b>	<b>1.05</b>	<b>0.95</b>
<b>100</b>	<b>0.15</b>		<b>0.90</b>
<b>150</b>	<b>0.23</b>		<b>0.50</b>
<b>150</b>	<b>0.23</b>		<b>-0.45</b>
<b>175</b>	<b>0.27</b>	<b>1.05</b>	
<b>225</b>	<b>0.35</b>	<b>-0.07</b>	
<b>300</b>	<b>0.46</b>		<b>-0.45</b>
<b>430</b>	<b>0.66</b>		<b>-0.20</b>
<b>600</b>	<b>0.93</b>	<b>0.05</b>	<b>-0.05</b>
<b>750</b>	<b>1.16</b>	<b>0.05</b>	<b>-0.05</b>



Figure 16-4 JITTER TOLERANCE

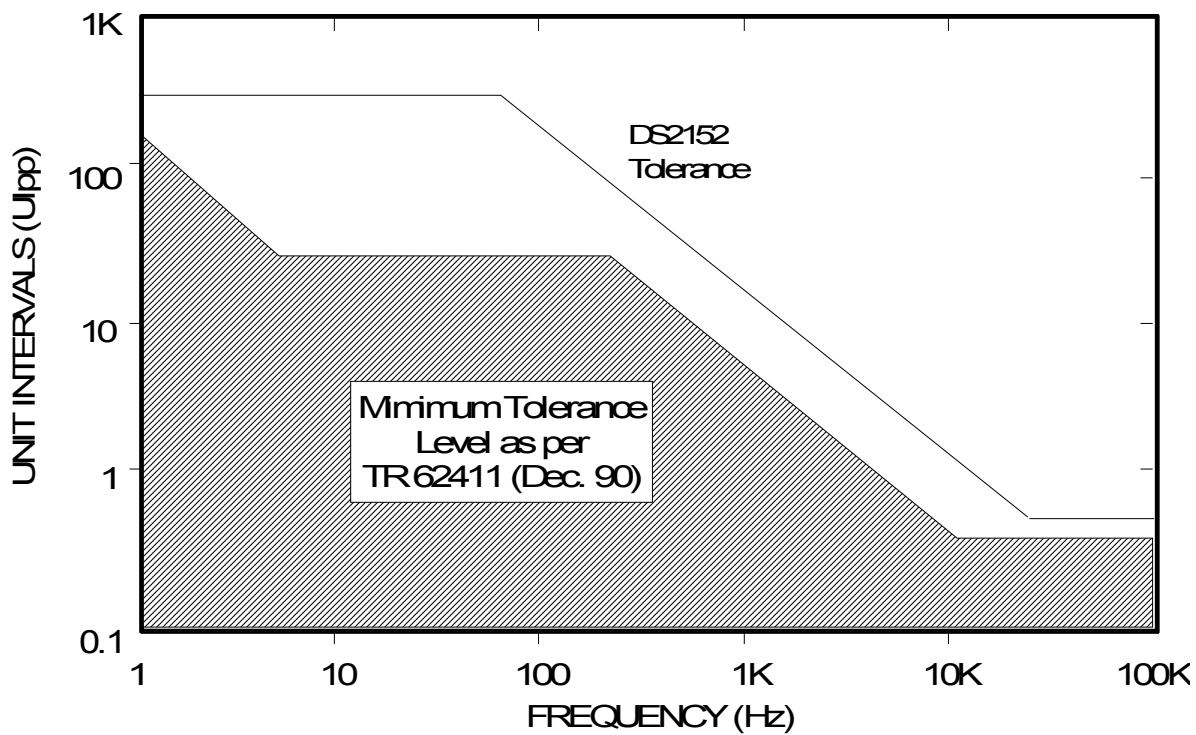
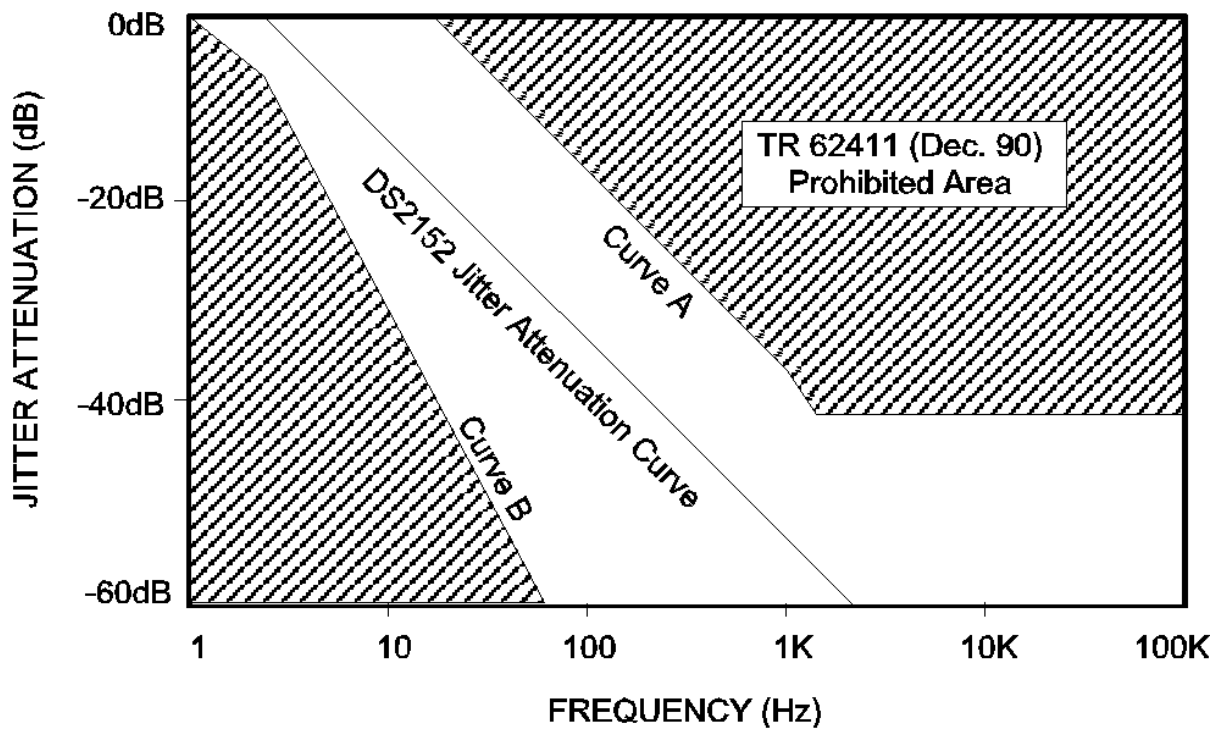

Figure 16-5 JITTER ATTENUATION



## 16.4 PROTECTED INTERFACES

In certain applications, such as connecting to the PSTN, it is required that the network interface be protected from and resistant to certain electrical conditions. These conditions are divided into two categories, surge and power line cross. A typical cause of surge is lightning strike. Power line cross refers to accidental contact with high voltage power wiring. For protection against surges, additional components and PCB layout considerations are required to reroute and dissipate this energy. In a surge event, the network interface must not be damaged and continue to work after the event. In the event of a power line contact, components such as fuses or PTCs that can “open” the circuit are required to prevent the possibility of a fire caused by overheating the transformer. The circuit examples in this data sheet are for “Secondary Over Voltage Protection” schemes for the line terminating equipment. Primary protection is typically provided by the network service provide and is external to the equipment.

Figure 16-6 shows an example circuit for the 5 volt device and Figure 16-7 is an example for the 3.3 volt device. In both examples, fuses are used to provide protection against power line cross. 470 ohm input resistors on the receive pair, a transient suppresser and a diode bridge on the transmit pair provide surge protection. Resistors R1 – R4 provide surge protection for the fuse. Careful selection of the transformer will allow the use of a fuse that requires no additional surge protection such as the circuit shown in Figure 16-7. The circuit shown in Figure 16-7 is required for 3.3 volt operation since additional resistance in the transmit pair cannot be tolerated. For more information on line interface design, consult the T1 Line Interface Design Criteria (note 353) and Secondary Over Voltage Protection (note 324) application notes. These notes are available from Dallas Semiconductor’s web site.

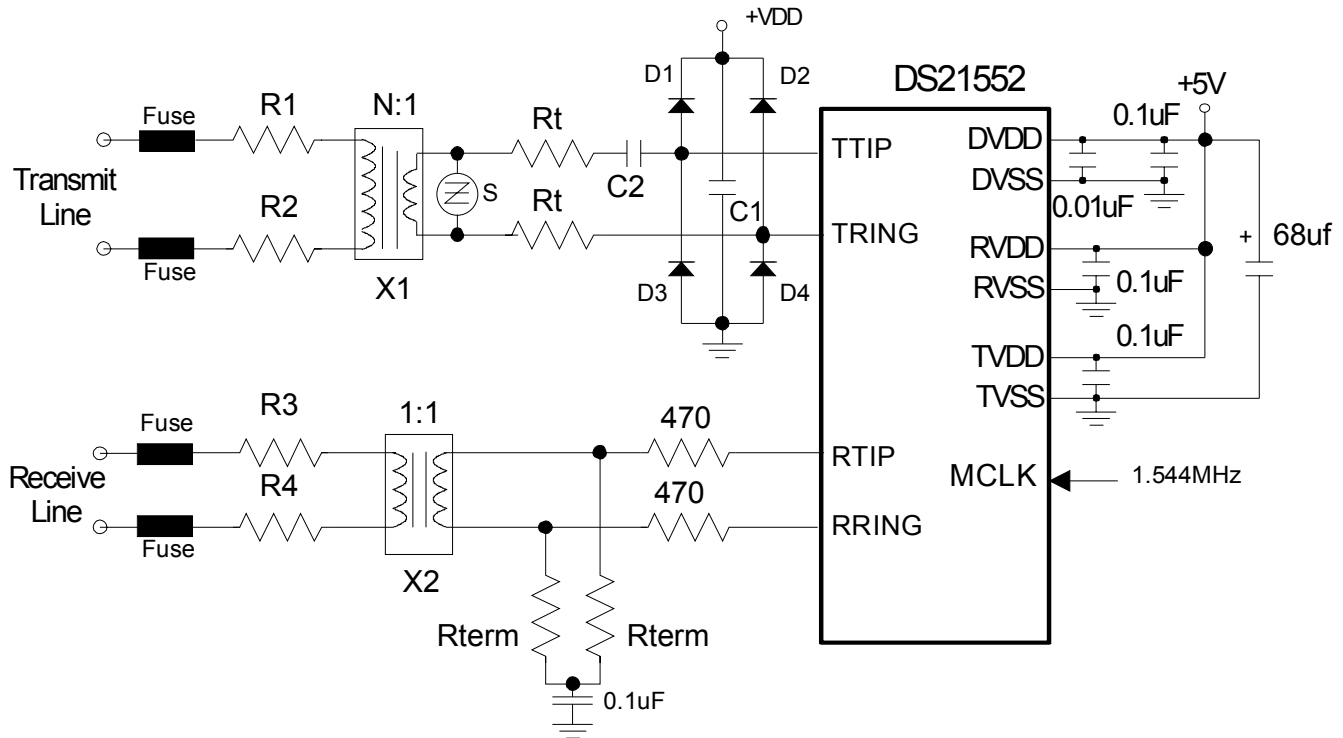
**Figure 16-6 PROTECTED INTERFACE EXAMPLE FOR THE DS21552****Note:**

The 68uf cap is required to maintain VDD during a transient event.

COMPONENT	DESCRIPTION
D1 – D4	Schottky Diode, International Rectifier 11DQ04
C1	0.1uf ceramic in parallel with 10uf tantalum
C2	.47 uf, non polarized ceramic construction
S	Semtech LC01-6, 6V low capacitance TVS
Fuse	For more information on the selection of these components see the separate application notes on <b>Secondary Over Voltage Protection</b> and <b>T1 Network Interface Design Criteria</b> . These applications notes are available from Dallas Semiconductor's Web site at <a href="http://www.dalsemi.com">www.dalsemi.com</a>
Rt	
Rterm	
R1, R2, R3, R4	
X1	
X2	

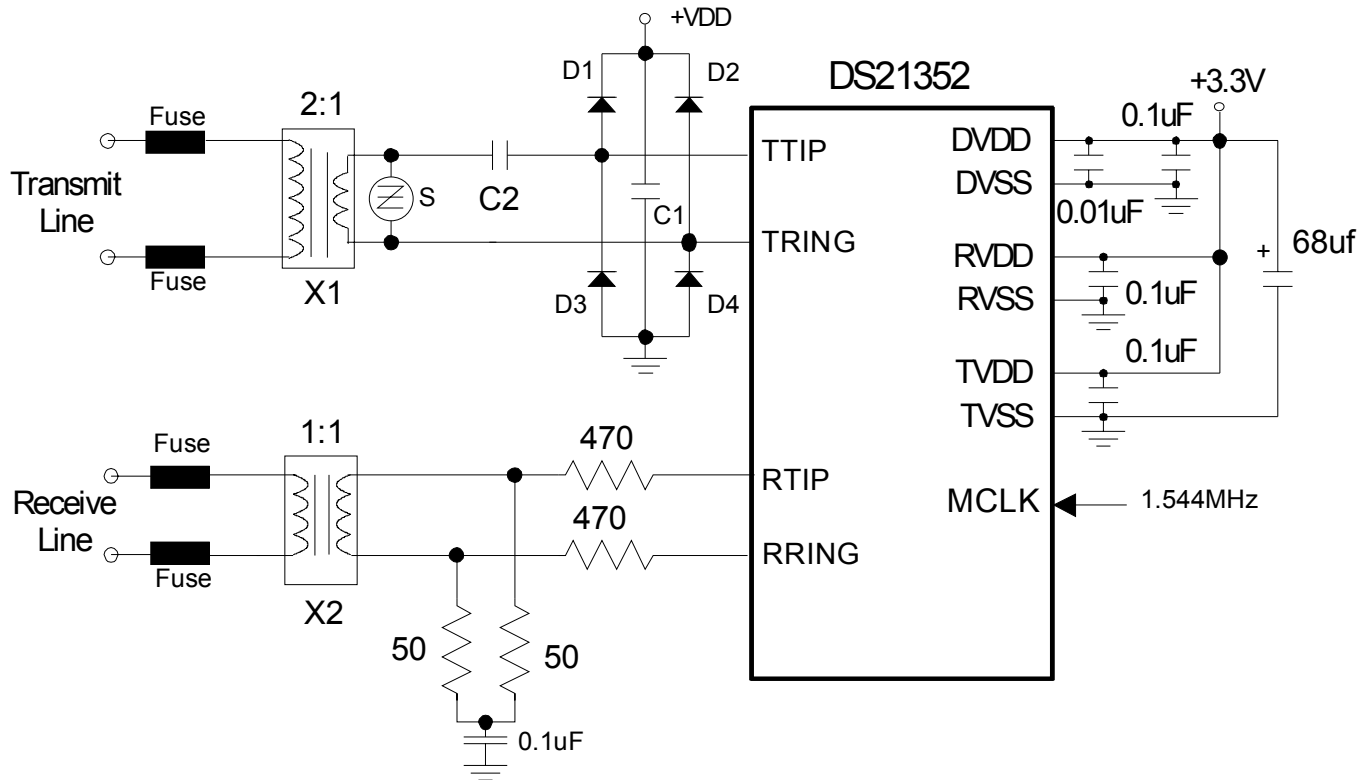
**Figure 16-7 PROTECTED INTERFACE EXAMPLE FOR THE DS21352****Note:**

The 68uf cap is required to maintain VDD levels during a transient event.

COMPONENT	DESCRIPTION
D1 – D4	Schottky Diode, International Rectifier 11DQ04
C1	0.1uf ceramic in parallel with 10uf tantalum
C2	.47 uf, non polarized ceramic construction
Fuse	1.25A slo-blo, Littlefuse V2301.25
S	Semtech LC01-6, 6V low capacitance TVS
X1, X2	Transpower PT314, Low DCR

## 16.5 RECEIVE MONITOR MODE

When connecting to a monitor port a large resistive loss is incurred due to the voltage divider between the T1 line termination resistors ( $R_t$ ) and the monitor port isolation resistors ( $R_m$ ) as shown below. The  $R_m$  resistors are typically 470 ohm. This, along with the 100 ohm termination ( $R_t$ ), produces 20dB of loss. The receiver of the DS21352/552 can provide gain to overcome the resistive loss of a monitor connection. This is a purely resistive loss/gain and should not be confused with the cable loss characteristics of a T1 transmission line. Via the TEST2 register as shown in the table below, the receiver can be programmed to provide both 12dB and 20dB of gain.

**Figure 16-8 TYPICAL MONITOR PORT APPLICATION**

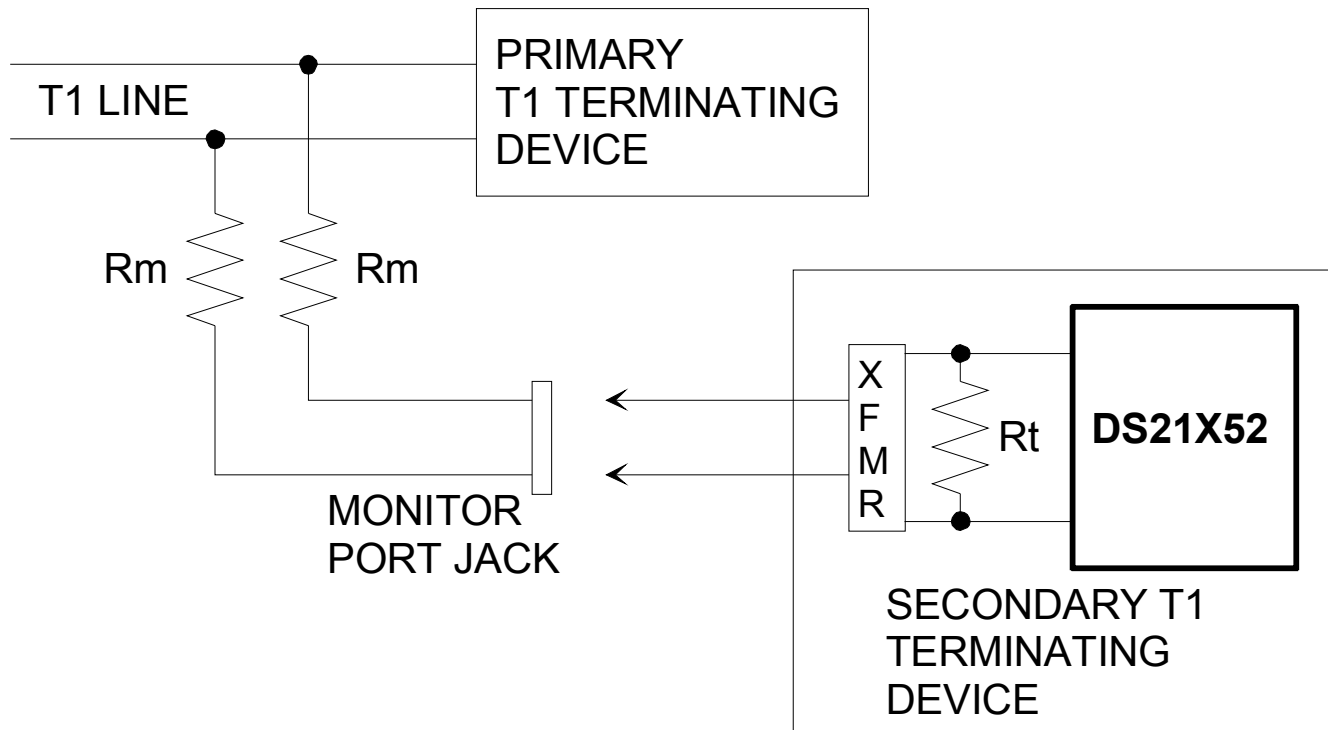

**Table 16-5 RECEIVE MONITOR MODE GAIN**

TEST2 (Address = 09 Hex) Register Value	Gain
72 Hex	12dB
70 Hex	20dB

## 17. PROGRAMMABLE IN-BAND LOOP CODE GENERATION AND DETECTION

Each framer in the DS21352/552 has the ability to generate and detect a repeating bit pattern that is from one to eight bits in length. To transmit a pattern, the user will load the pattern to be sent into the Transmit Code Definition (TCD) register and select the proper length of the pattern by setting the TC0 and TC1 bits in the In-Band Code Control (IBCC) register. Once this is accomplished, the pattern will be transmitted as long as the TLOOP control bit (CCR3.1) is enabled. Normally (unless the transmit formatter is programmed to not insert the F-bit position) the framer will overwrite the repeating pattern once every 193 bits to allow the F-bit position to be sent. As an example, if the user wished to transmit the standard “loop up” code for Channel Service Units which is a repeating pattern of ...10000100001... then 80h would be loaded into TDR and the length would set to 5 bits.

Each framer can detect two separate repeating patterns to allow for both a “loop up” code and a “loop down” code to be detected. The user will program the codes to be detected in the Receive Up Code Definition (RUPCD) register and the Receive Down Code Definition (RDNCD) register and the length of each pattern will be selected via the IBCC register. The framer will detect repeating pattern codes in both framed and unframed circumstances with bit error rates as high as  $10E-2$ . The code detector has a nominal integration period of 48 ms. Hence, after about 48 ms of receiving either code, the proper status bit (LUP at SR1.7 and LDN at SR1.6) will be set to a one. Normally codes are sent for a period of 5 seconds. it is recommend that the software poll the framer every 100 ms to 1000 ms until 5 seconds has elapsed to insure that the code is continuously present.

### IBCC: IN-BAND CODE CONTROL REGISTER (Address=12 Hex)

(MSB)				(LSB)			
TC1	TC0	RUP2	RUP1	RUP0	RDN2	RDN1	RDN0

SYMBOL	POSITION	NAME AND DESCRIPTION
TC1	IBCC.7	<b>Transmit Code Length Definition Bit 1.</b> See Table 17-1
TC0	IBCC.6	<b>Transmit Code Length Definition Bit 0.</b> See Table 17-1
RUP2	IBCC.5	<b>Receive Up Code Length Definition Bit 2.</b> See Table 17-2
RUP1	IBCC.4	<b>Receive Up Code Length Definition Bit 1.</b> See Table 17-2
RUP0	IBCC.3	<b>Receive Up Code Length Definition Bit 0.</b> See Table 17-2
RDN2	IBCC.2	<b>Receive Down Code Length Definition Bit 2.</b> See Table 17-2
RDN1	IBCC.1	<b>Receive Down Code Length Definition Bit 1.</b> See Table 17-2
RDN0	IBCC.0	<b>Receive Down Code Length Definition Bit 0.</b> See Table 17-2

**Table 17-1 TRANSMIT CODE LENGTH**

TC1	TC0	LENGTH SELECTED
0	0	5 bits
0	1	6 bits / 3 bits
1	0	7 bits
1	1	8 bits / 4 bits / 2 bits / 1 bits

**Table 17-2 RECEIVE CODE LENGTH**

RUP2/ RDN2	RUP1/ RDN1	RUP0/ RDN0	LENGTH SELECTED
0	0	0	1 bits
0	0	1	2 bits
0	1	0	3 bits
0	1	1	4 bits
1	0	0	5 bits
1	0	1	6 bits
1	1	0	7 bits
1	1	1	8 bits

**TCD: TRANSMIT CODE DEFINITION REGISTER (Address=13 Hex)**

(MSB)							(LSB)
C7	C6	C5	C4	C3	C2	C1	C0

SYMBOL	POSITION	NAME AND DESCRIPTION
C7	TCD.7	<b>Transmit Code Definition Bit 7.</b> First bit of the repeating pattern.
C6	TCD.6	<b>Transmit Code Definition Bit 6.</b>
C5	TCD.5	<b>Transmit Code Definition Bit 5.</b>
C4	TCD.4	<b>Transmit Code Definition Bit 4.</b>
C3	TCD.3	<b>Transmit Code Definition Bit 3.</b>
C2	TCD.2	<b>Transmit Code Definition Bit 2.</b> A Don't Care if a 5 bit length is selected.
C1	TCD.1	<b>Transmit Code Definition Bit 1.</b> A Don't Care if a 5 or 6 bit length is selected.
C0	TCD.0	<b>Transmit Code Definition Bit 0.</b> A Don't Care if a 5, 6 or 7 bit length is selected.

**RUPCD: RECEIVE UP CODE DEFINITION REGISTER (Address=14 Hex)**

(MSB)							(LSB)
C7	C6	C5	C4	C3	C2	C1	C0

SYMBOL	POSITION	NAME AND DESCRIPTION
C7	RUPCD.7	<b>Receive Up Code Definition Bit 7.</b> First bit of the repeating pattern.
C6	RUPCD.6	<b>Receive Up Code Definition Bit 6.</b> A Don't Care if a 1 bit length is selected.
C5	RUPCD.5	<b>Receive Up Code Definition Bit 5.</b> A Don't Care if a 1 or 2 bit length is selected.
C4	RUPCD.4	<b>Receive Up Code Definition Bit 4.</b> A Don't Care if a 1 to 3 bit length is selected.
C3	RUPCD.3	<b>Receive Up Code Definition Bit 3.</b> A Don't Care if a 1 to 4 bit length is selected.
C2	RUPCD.2	<b>Receive Up Code Definition Bit 2.</b> A Don't Care if a 1 to 5 bit length is selected.
C1	RUPCD.1	<b>Receive Up Code Definition Bit 1.</b> A Don't Care if a 1 to 6 bit length is selected.
C0	RUPCD.0	<b>Receive Up Code Definition Bit 0.</b> A Don't Care if a 1 to 7 bit length is selected.

**RDNCD: RECEIVE DOWN CODE DEFINITION REGISTER (Address=15 Hex)**

(MSB)							(LSB)
C7	C6	C5	C4	C3	C2	C1	C0

SYMBOL	POSITION	NAME AND DESCRIPTION
C7	RDNCD.7	<b>Receive Down Code Definition Bit 7.</b> First bit of the repeating pattern.
C6	RDNCD.6	<b>Receive Down Code Definition Bit 6.</b> A Don't Care if a 1 bit length is selected.
C5	RDNCD.5	<b>Receive Down Code Definition Bit 5.</b> A Don't Care if a 1 or 2 bit length is selected.
C4	RDNCD.4	<b>Receive Down Code Definition Bit 4.</b> A Don't Care if a 1 to 3 bit length is selected.
C3	RDNCD.3	<b>Receive Down Code Definition Bit 3.</b> A Don't Care if a 1 to 4 bit length is selected.
C2	RDNCD.2	<b>Receive Down Code Definition Bit 2.</b> A Don't Care if a 1 to 5 bit length is selected.
C1	RDNCD.1	<b>Receive Down Code Definition Bit 1.</b> A Don't Care if a 1 to 6 bit length is selected.
C0	RDNCD.0	<b>Receive Down Code Definition Bit 0.</b> A Don't Care if a 1 to 7 bit length is selected.



## 18. TRANSMIT TRANSPARENCY

Each of the 24 T1 channels in the transmit direction of the framer can be either forced to be transparent or in other words, can be forced to stop Bit 7 Stuffing and/or Robbed Signaling from overwriting the data in the channels. Transparency can be invoked on a channel by channel basis by properly setting the TTR1, TTR2, and TTR3 registers.

### TTR1/TTR2/TTR3: TRANSMIT TRANSPARENCY REGISTER (Address=39 to 3B Hex)

(MSB)				(LSB)				
CH8	CH7	CH6	CH5	CH4	CH3	CH2	CH1	TTR1 (39)
CH16	CH15	CH14	CH13	CH12	CH11	CH10	CH9	TTR2 (3A)
CH24	CH23	CH22	CH21	CH20	CH19	CH18	CH17	TTR3 (3B)

SYMBOLS	POSITIONS	NAME AND DESCRIPTION
CH1-24	TTR1.0-3.7	<b>Transmit Transparency Registers.</b> 0 = this DS0 channel is not transparent 1 = this DS0 channel is transparent

Each of the bit position in the Transmit Transparency Registers (TTR1/TTR2/TTR3) represent a DS0 channel in the outgoing frame. When these bits are set to a one, the corresponding channel is transparent (or clear). If a DS0 is programmed to be clear, no robbed bit signaling will be inserted nor will the channel have Bit 7 stuffing performed. However, in the D4 framing mode, bit 2 will be overwritten by a zero when a Yellow Alarm is transmitted. Also the user has the option to prevent the TTR registers from determining which channels are to have Bit 7 stuffing performed. If the TCR2.0 and TCR1.3 bits are set to one, then all 24 T1 channels will have Bit 7 stuffing performed on them regardless of how the TTR registers are programmed. In this manner, the TTR registers are only affecting which channels are to have robbed bit signaling inserted into them.

## 19. JTAG-BOUNDARY SCAN ARCHITECTURE AND TEST ACCESS PORT

### 19.1 DESCRIPTION

The DS21352/552 IEEE 1149.1 design supports the standard instruction codes SAMPLE/PRELOAD, BYPASS, and EXTEST. Optional public instructions included are HIGHZ, CLAMP, and IDCODE. See Figure 19-1. The DS21352/552 contains the following as required by IEEE 1149.1 Standard Test Access Port and Boundary Scan Architecture.

- Test Access Port (TAP)
- TAP Controller
- Instruction Register
- Bypass Register
- Boundary Scan Register
- Device Identification Register

The DS21352/552 are enhanced versions of the DS2152 and are backward pin-compatible. The JTAG feature uses pins that had no function in the DS2152. When using the JTAG feature, be sure FMS (pin 76) is tied LOW enabling the newly defined pins of the DS21352/552. Details on Boundary Scan Architecture and the Test Access Port can be found in IEEE 1149.1-1990, IEEE 1149.1a-1993, and IEEE 1149.1b-1994.

The Test Access Port has the necessary interface pins; JTRST, JTCLK, JTMS, JTDI, and JTDO. See the pin descriptions for details.

**Figure 19-1 JTAG FUNCTIONAL BLOCK DIAGRAM**

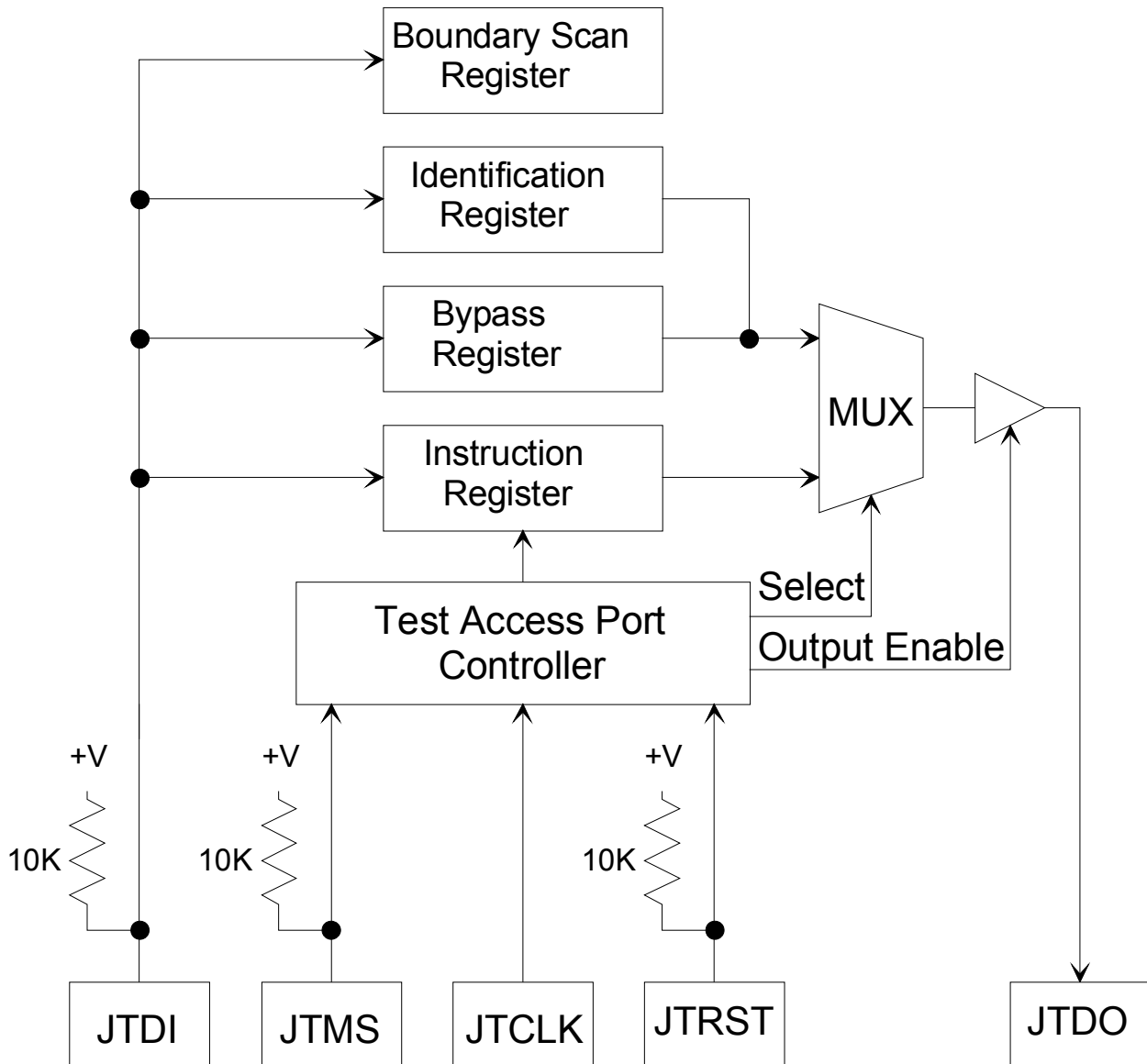

## 19.2 TAP CONTROLLER STATE MACHINE

The TAP controller is a finite state machine that responds to the logic level at JTMS on the rising edge of JTCLK. See Figure 19-1.

### TEST-LOGIC-RESET

Upon power up, the TAP Controller will be in the Test-Logic-Reset state. The Instruction register will contain the IDCODE instruction. All system logic of the device will operate normally.

### RUN-TEST-IDLE

The Run-Test-Idle is used between scan operations or during specific tests. The Instruction register and test registers will remain idle.

### SELECT-DR-SCAN

All test registers retain their previous state. With JTMS LOW, a rising edge of JTCLK moves the controller into the Capture-DR state and will initiate a scan sequence. JTMS HIGH during a rising edge on JTCLK moves the controller to the Select-IR-Scan state.

### CAPTURE-DR

Data may be parallel-loaded into the test data registers selected by the current instruction. If the instruction does not call for a parallel load or the selected register does not allow parallel loads, the test register will remain at its current value. On the rising edge of JTCLK, the controller will go to the Shift-DR state if JTMS is LOW or it will go to the Exit1-DR state if JTMS is HIGH.

### SHIFT-DR

The test data register selected by the current instruction will be connected between JTDI and JTDO and will shift data one stage towards its serial output on each rising edge of JTCLK. If a test register selected by the current instruction is not placed in the serial path, it will maintain its previous state.

### EXIT1-DR

While in this state, a rising edge on JTCLK will put the controller in the Update-DR state, which terminates the scanning process, if JTMS is HIGH. A rising edge on JTCLK with JTMS LOW will put the controller in the Pause-DR state.

### PAUSE-DR

Shifting of the test registers is halted while in this state. All test registers selected by the current instruction will retain their previous state. The controller will remain in this state while JTMS is LOW. A rising edge on JTCLK with JTMS HIGH will put the controller in the Exit2-DR state.

### EXIT2-DR

A rising edge on JTCLK with JTMS HIGH while in this state will put the controller in the Update-DR state and terminate the scanning process. A rising edge on JTCLK with JTMS LOW will enter the Shift-DR state.

### UPDATE-DR

A falling edge on JTCLK while in the Update-DR state will latch the data from the shift register path of the test registers into the data output latches. This prevents changes at the parallel output due to changes in the shift register.

## **SELECT-IR-SCAN**

All test registers retain their previous state. The instruction register will remain unchanged during this state. With JTMS LOW, a rising edge on JTCLK moves the controller into the Capture-IR state and will initiate a scan sequence for the instruction register. JTMS HIGH during a rising edge on JTCLK puts the controller back into the Test-Logic-Reset state.

## **CAPTURE-IR**

The Capture-IR state is used to load the shift register in the instruction register with a fixed value. This value is loaded on the rising edge of JTCLK. If JTMS is HIGH on the rising edge of JTCLK, the controller will enter the Exit1-IR state. If JTMS is LOW on the rising edge of JTCLK, the controller will enter the Shift-IR state.

## **SHIFT-IR**

In this state, the shift register in the instruction register is connected between JTDI and JTDO and shifts data one stage for every rising edge of JTCLK towards the serial output. The parallel register, as well as all test registers, remain at their previous states. A rising edge on JTCLK with JTMS HIGH will move the controller to the Exit1-IR state. A rising edge on JTCLK with JTMS LOW will keep the controller in the Shift-IR state while moving data one stage through the instruction shift register.

## **EXIT1-IR**

A rising edge on JTCLK with JTMS LOW will put the controller in the Pause-IR state. If JTMS is HIGH on the rising edge of JTCLK, the controller will enter the Update-IR state and terminate the scanning process.

## **PAUSE-IR**

Shifting of the instruction shift register is halted temporarily. With JTMS HIGH, a rising edge on JTCLK will put the controller in the Exit2-IR state. The controller will remain in the Pause-IR state if JTMS is LOW during a rising edge on JTCLK.

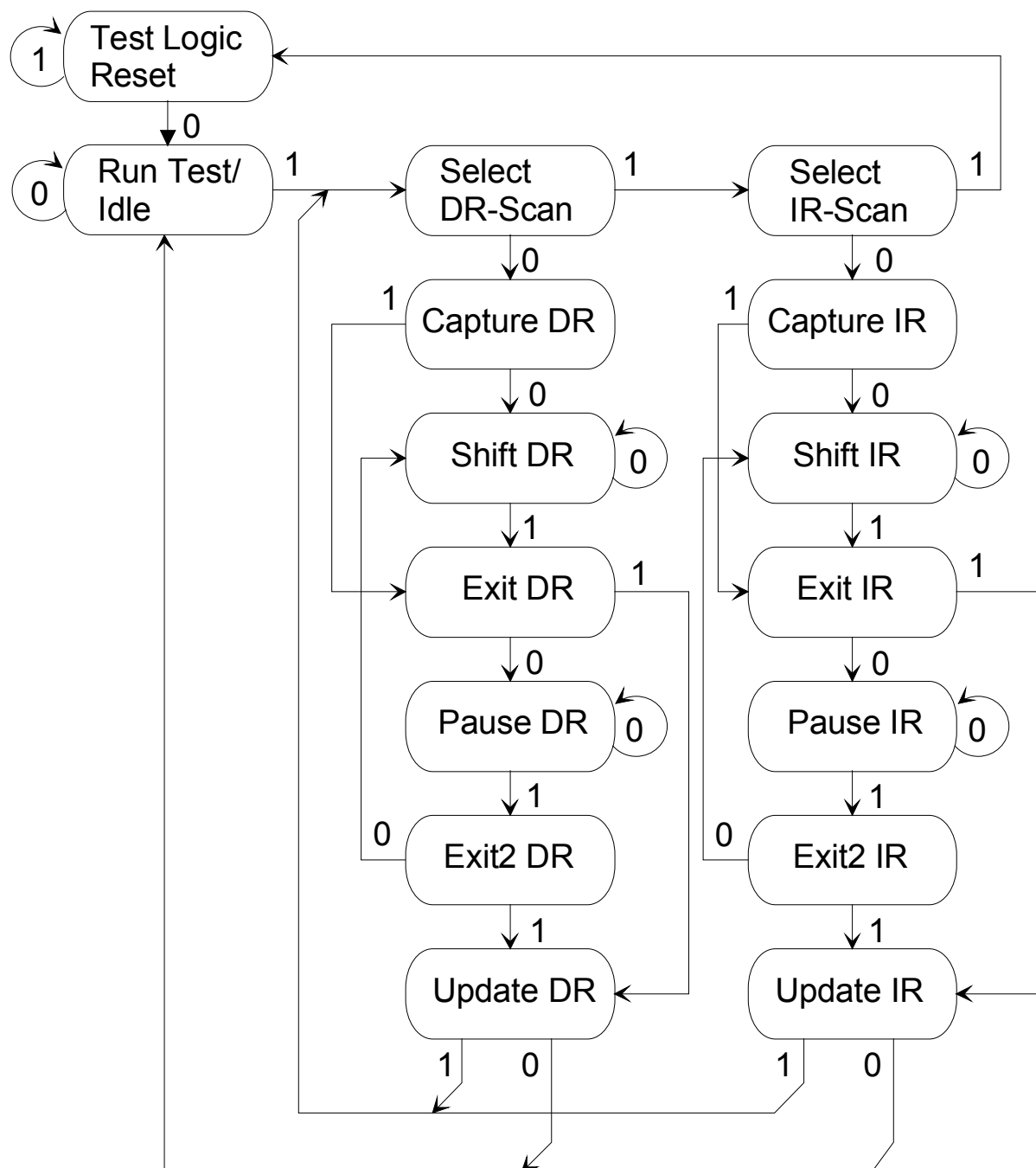
**Figure 19-2 TAP CONTROLLER STATE DIAGRAM**

### 19.3 INSTRUCTION REGISTER

The instruction register contains a shift register as well as a latched parallel output and is 3 bits in length. When the TAP controller enters the Shift-IR state, the instruction shift register will be connected between JTDI and JTDO. While in the Shift-IR state, a rising edge on JTCLK with JTMS LOW will shift the data one stage towards the serial output at JTDO. A rising edge on JTCLK in the Exit1-IR state or the Exit2-IR state with JTMS HIGH will move the controller to the Update-IR state. The falling edge of that same JTCLK will latch the data in the instruction shift register to the instruction parallel output. Instructions supported by the DS21352/552 with their respective operational binary codes are shown in Table 19-1.

**Table 19-1 INSTRUCTION CODES FOR IEEE 1149.1 ARCHITECTURE**

Instruction	Selected Register	Instruction Codes
SAMPLE/PRELOAD	Boundary Scan	010
BYPASS	Bypass	111
EXTEST	Boundary Scan	000
CLAMP	Bypass	011
HIGHZ	Bypass	100
IDCODE	Device Identification	001

## **SAMPLE/PRELOAD**

This is a mandatory instruction for the IEEE 1149.1 specification. This instruction supports two functions. The digital I/Os of the device can be sampled at the boundary scan register without interfering with the normal operation of the device by using the Capture-DR state. SAMPLE/PRELOAD also allows the device to shift data into the boundary scan register via JTDI using the Shift-DR state.

## **BYPASS**

When the BYPASS instruction is latched into the parallel instruction register, JTDI connects to JTDO through the one-bit bypass test register. This allows data to pass from JTDI to JTDO not affecting the device's normal operation.

## **EXTEST**

This allows testing of all interconnections to the device. When the EXTEST instruction is latched in the instruction register, the following actions occur. Once enabled via the Update-IR state, the parallel outputs of all digital output pins will be driven. The boundary scan register will be connected between JTDI and JTDO. The Capture-DR will sample all digital inputs into the boundary scan register.

## **CLAMP**

All digital outputs of the device will output data from the boundary scan parallel output while connecting the bypass register between JTDI and JTDO. The outputs will not change during the CLAMP instruction.

## **HIGHZ**

All digital outputs of the device will be placed in a high impedance state. The BYPASS register will be connected between JTDI and JTDO.

## **EXIT2-IR**

A rising edge on JTCLK with JTMS LOW will put the controller in the Update-IR state. The controller will loop back to Shift-IR if JTMS is HIGH during a rising edge of JTCLK in this state.

## **UPDATE-IR**

The instruction code shifted into the instruction shift register is latched into the parallel output on the falling edge of JTCLK as the controller enters this state. Once latched, this instruction becomes the current instruction. A rising edge on JTCLK with JTMS LOW, will put the controller in the Run-Test-Idle state. With JTMS HIGH, the controller will enter the Select-DR-Scan state.

## IDCODE

When the IDCODE instruction is latched into the parallel instruction register, the identification test register is selected. The device identification code will be loaded into the identification register on the rising edge of JTCLK following entry into the Capture-DR state. Shift-DR can be used to shift the identification code out serially via JTDO. During Test-Logic-Reset, the identification code is forced into the instruction register's parallel output. The ID code will always have a '1' in the LSB position. The next 11 bits identify the manufacturer's JEDEC number and number of continuation bytes followed by 16 bits for the device and 4 bits for the version. See Table 19-2. Table 19-3 lists the device ID codes for the SCT devices.

**Table 19-2 ID CODE STRUCTURE**

MSB			LSB
Version	Device ID	JEDEC	1
Contact Factory			
4 bits	16bits	00010100001	1

**Table 19-3 DEVICE ID CODES**

DEVICE	16-BIT ID
DS21354	0005h
DS21554	0003h
DS21352	0004h
DS21552	0002h

## 19.4 TEST REGISTERS

IEEE 1149.1 requires a minimum of two test registers; the bypass register and the boundary scan register. An optional test register has been included with the DS21352/552 design. This test register is the identification register and is used in conjunction with the IDCODE instruction and the Test-Logic-Reset state of the TAP controller.

### BOUNDARY SCAN REGISTER

This register contains both a shift register path and a latched parallel output for all control cells and digital I/O cells and is n bits in length. See Table 19-4 for all of the cell bit locations and definitions.

### BYPASS REGISTER

This is a single one-bit shift register used in conjunction with the BYPASS, CLAMP, and HIGHZ instructions which provides a short path between JTDI and JTDO.

## IDENTIFICATION REGISTER

The identification register contains a 32-bit shift register and a 32-bit latched parallel output. This register is selected during the IDCODE instruction and when the TAP controller is in the Test-Logic-Reset state. See Table 19-2. Table 19-3 lists the device ID codes for the SCT devices.

**Table 19-4 BOUNDARY SCAN CONTROL BITS**

BIT	PIN	SYMBOL	TYPE	CONTROL BIT DESCRIPTION
2	1	RCHBLK	O	
	2	JTMS	I	
1	3	8MCLK	O	
	4	JTCLK	I	
	5	JTRST	I	
0	6	RCL	O	
	7	JTDI	I	
	8	N/C	–	
	9	N/C	–	
	10	JTDO	O	
72	11	BTS	I	
71	12	LIUC	I	
70	13	8XCLK	O	
69	14	TEST	I	
68	15	NC	–	
	16	RTIP	I	
	17	RRING	I	
	18	RVDD	–	
	19	RVSS	–	
	20	RVSS	–	
	21	MCLK	I	
	22	XTALD	O	
67	23	NC	–	
	24	RVSS	–	
66	25	INT	O	
	26	N/C	–	
	27	N/C	–	
	28	N/C	–	
	29	TTIP	O	
	30	TVSS	–	
	31	TVDD	–	
	32	TRING	O	
65	33	TCHBLK	O	
64	34	TLCLK	O	
63	35	TLINK	I	
62	36	CI	I	
61	–	TSYNC.cntl	–	0 = TSYNC an input 1 = TSYNC an output
60	37	TSYNC	I/O	

**Table 19-4 BOUNDARY SCAN CONTROL BITS (cont.)**

BIT	PIN	SYMBOL	TYPE	CONTROL BIT DESCRIPTION
59	38	TPOSI	I	
58	39	TNEGI	I	
57	40	TCLKI	I	
56	41	TCLKO	O	
55	42	TNEGO	O	
54	43	TPOSO	O	
	44	DVDD	–	



	45	DVSS	–	
53	46	TCLK	I	
52	47	TSER	I	
51	48	TSIG	I	
50	49	TESO	O	
49	50	TDATA	I	
48	51	TSYSCLK	I	
47	52	TSSYNC	I	
46	53	TCHCLK	O	
45	54	CO	O	
44	55	MUX	I	
43	–	BUS.cntl	–	0 = D0-D7/AD0-AD7 are inputs 1 = D0-D7/AD0-AD7 are outputs
42	56	D0/AD0	I/O	
41	57	D1/AD1	I/O	
40	58	D2/AD2	I/O	
39	59	D3/AD3	I/O	
	60	DVSS	–	
	61	DVDD	–	
38	62	D4/AD4	I/O	
37	63	D5/AD5	I/O	
36	64	D6/AD6	I/O	
35	65	D7/AD7	I/O	
34	66	A0	I	
33	67	A1	I	
32	68	A2	I	
31	69	A3	I	
30	70	A4	I	
29	71	A5	I	
28	72	A6	I	
27	73	ALE(AS)/A7	I	
26	74	RD*(DS*)	I	
25	75	CS*	I	
24	76	FMS	I	
23	77	WR*(R/W*)	I	
22	78	RLINK	O	
21	79	RLCLK	O	
	80	DVSS	–	

**Table 19-4 BOUNDARY SCAN CONTROL BITS (cont.)**

BIT	PIN	SYMBOL	TYPE	CONTROL BIT DESCRIPTION
	81	DVDD		
20	82	RCLK	O	
	83	DVDD	–	
	84	DVSS	–	
19	85	RDATA	O	
18	86	RPOSI	I	
17	87	RNEGI	I	
16	88	RCLKI	I	
15	89	RCLKO	O	
14	90	RNEGO	O	
13	91	RPOSO	O	
12	92	RCHCLK	O	
11	93	RSIGF	O	
10	94	RSIG	O	
9	95	RSER	O	
8	96	RMSYNC	O	

7	97	RFSYNC	O	
6	–	RSYNC.cntl	–	0 = RSYNC an input 1 = RSYNC an output
5	98	RSYNC	I/O	
4	99	RLOS/LOTC	O	
3	100	RSYSCLK	I	

## 20. INTERLEAVED PCM BUS OPERATION

In many architectures, the outputs of individual framers are combined into higher speed serial buses to simplify transport across the system. The DS21352/552 can be configured to allow data and signaling buses to be multiplexed into higher speed data and signaling buses eliminating external hardware saving board space and cost.

The interleaved PCM bus option (IBO) supports two bus speeds. The 4.096 MHz bus speed allows two SCTs to share a common bus. The 8.192 MHz bus speed allows four SCTs to share a common bus. See Figure 20-1 for an example of 4 devices sharing a common 8.192MHz PCM bus. Each SCT that shares a common bus must be configured through software and requires the use of one or two device pins. The elastic stores of each SCT must be enabled and configured for 2.048 MHz operation. See Figure 21-6 and Figure 21-7.

For all bus configurations, one SCT will be configured as the master device and the remaining SCTs will be configured as slave devices. In the 4.096 MHz bus configuration there is one master and one slave. In the 8.192 MHz bus configuration there is one master and three slaves. Refer to the IBO register description for more detail.

### IBO: INTERLEAVE BUS OPERATION REGISTER (Address = 94 Hex)

(MSB)				(LSB)			
-	-	-	-	IBOEN	INTSEL	MSEL0	MSEL1

SYMBOL	POSITION	NAME AND DESCRIPTION
-	IBO.7	<b>Not Assigned.</b> Should be set to 0.
-	IBO.6	<b>Not Assigned.</b> Should be set to 0.
-	IBO.5	<b>Not Assigned.</b> Should be set to 0.
-	IBO.4	<b>Not Assigned.</b> Should be set to 0.
IBOEN	IBO.3	<b>Interleave Bus Operation Enable</b> 0 = Interleave Bus Operation disabled. 1 = Interleave Bus Operation enabled.
INTSEL	IBO.2	<b>Interleave Type Select</b> 0 = Byte interleave. 1 = Frame interleave.
MSEL0	IBO.1	<b>Master Device Bus Select Bit 0.</b> See Table 20-1.
MSEL1	IBO.0	<b>Master Device Bus Select Bit 1.</b> See Table 20-1.

**Table 20-1 MASTER DEVICE BUS SELECT**

MSEL1	MSEL0	Function
0	0	Slave device.
0	1	Master device with 1 slave device (4.096 MHz bus rate)
1	0	Master device with 3 slave devices (8.192 MHz bus rate)
1	1	Reserved

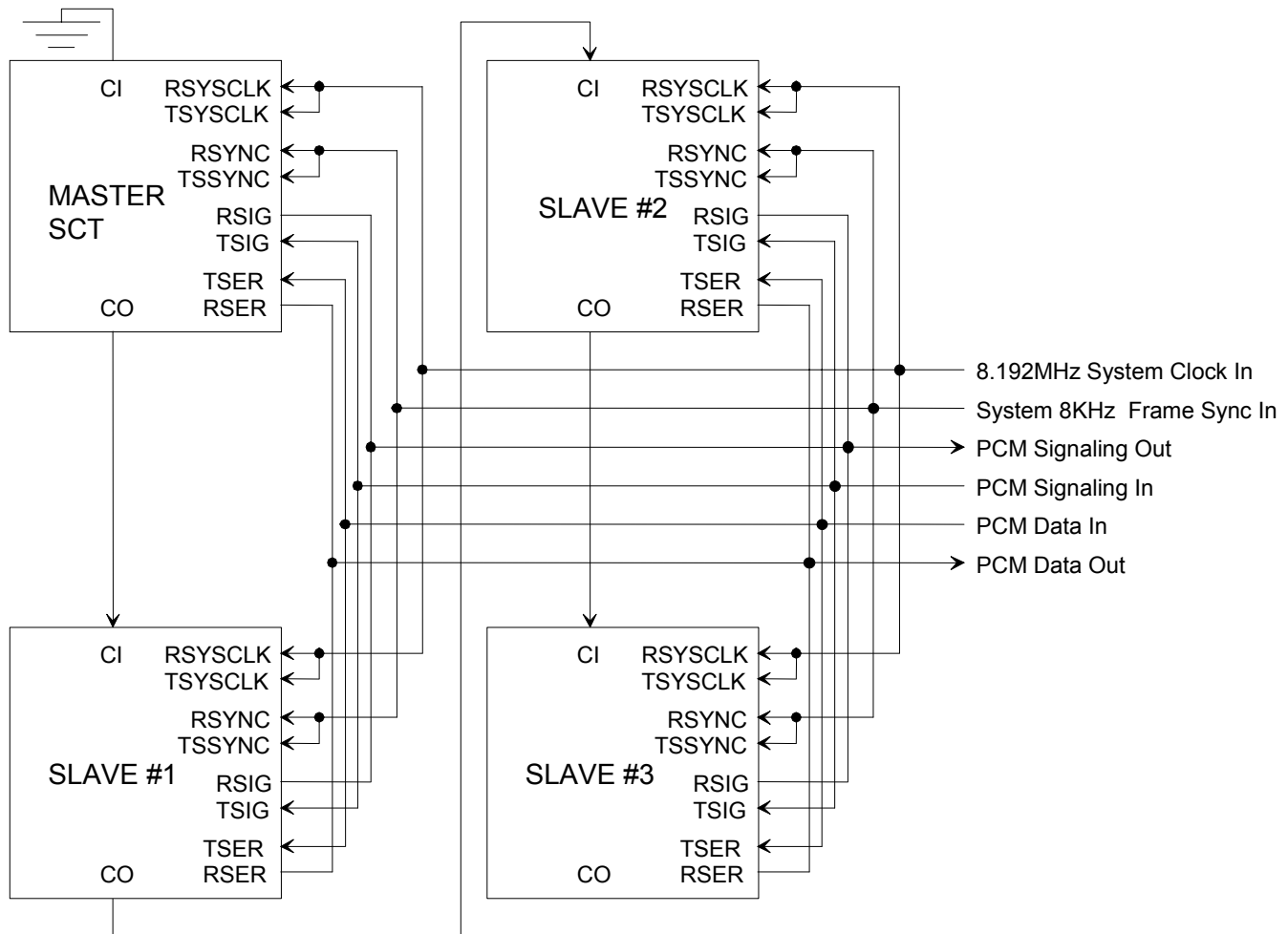
**Figure 20-1 IBO BASIC CONFIGURATION USING 4 SCTS**

## 20.1 CHANNEL INTERLEAVE

In channel interleave mode data is output to the PCM Data Out bus one channel at a time from each of the connected SCTs until all channels of frame n from all each SCT has been place on the bus. This mode can be used even when the connected SCTs are operating asynchronous to each other. The elastic stores will manage slip conditions. See Figure 21-13 for details.

## 20.2 FRAME INTERLEAVE

In frame interleave mode data is output to the PCM Data Out bus one frame at a time from each of the connected SCTs. This mode is used only when all connected SCTs are synchronous. In this mode, slip conditions are not allowed. See Figure 21-14 for details.

## 21. FUNCTIONAL TIMING DIAGRAMS

**Figure 21-1 RECEIVE SIDE D4 TIMING**

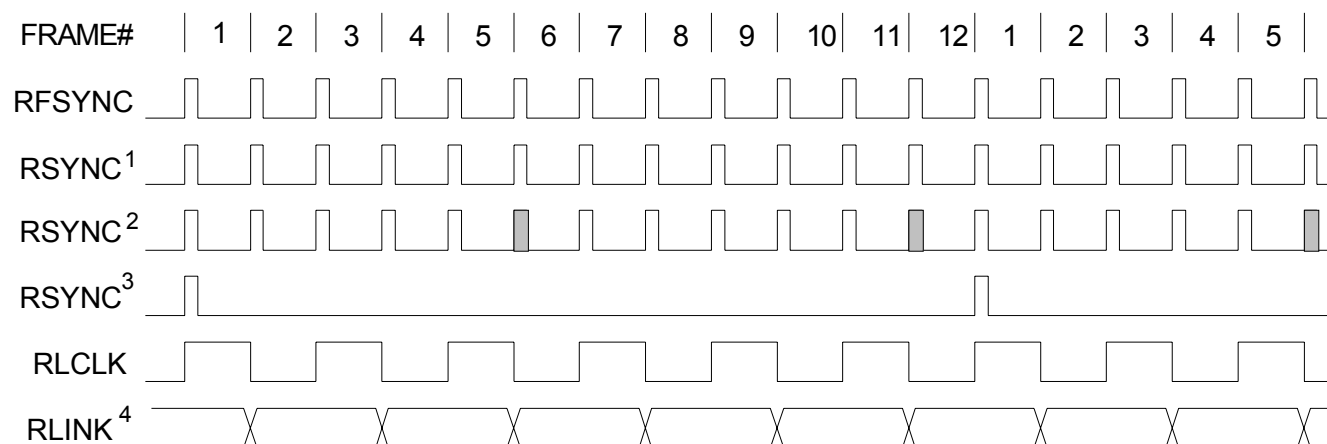

### Notes:

1. RSYNC in the frame mode (RCR2.4 = 0) and double-wide frame sync is not enabled (RCR2.5 = 0)
2. RSYNC in the frame mode (RCR2.4 = 0) and double-wide frame sync is enabled (RCR2.5 = 1)
3. RSYNC in the multiframe mode (RCR2.4 = 1)
4. RLINK data (Fs - bits) is updated one bit prior to even frames and held for two frames
5. RLINK and RLCLK are not synchronous with RSYNC when the receive side elastic store is enabled

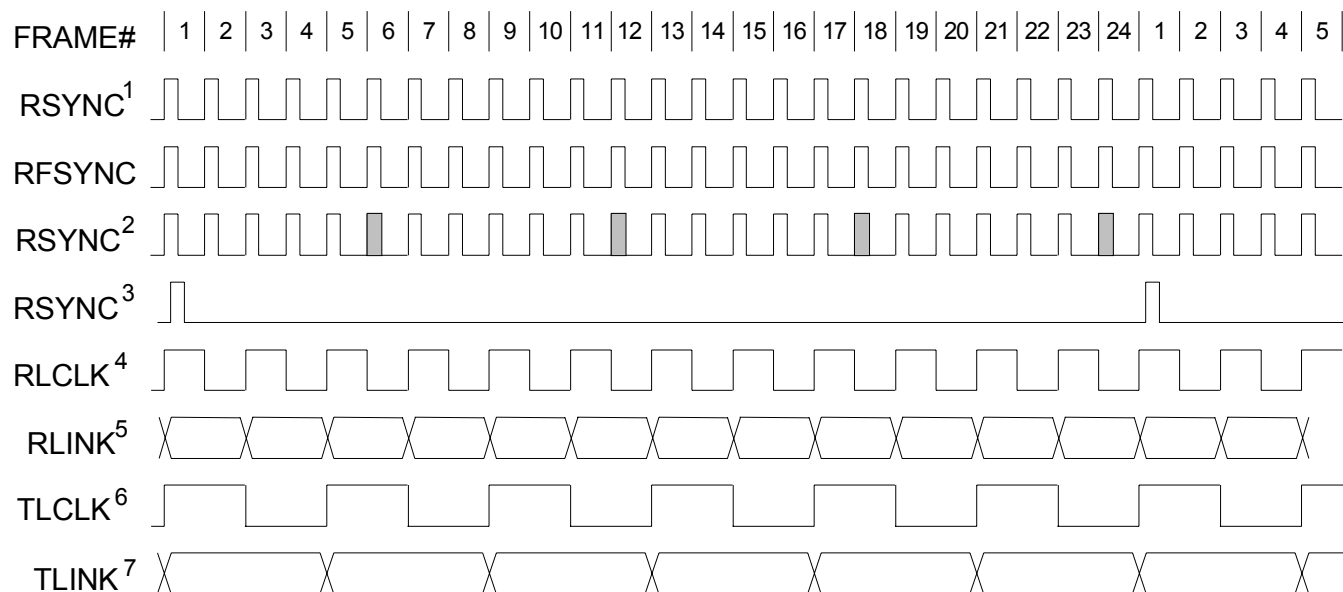
**Figure 21-2 RECEIVE SIDE ESF TIMING****Notes:**

1. RSYNC in frame mode (RCR2.4 = 0) and double wide frame sync is not enabled (RCR2.5 = 0)
2. RSYNC in frame mode (RCR2.4 = 0) and double wide frame sync is enabled (RCR2.5 = 1)
3. RSYNC in multiframe mode (RCR2.4 = 1)
4. ZBTISI mode disabled (RCR2.6 = 0)
5. RLINK data (FDL bits) is updated one bit time before odd frames and held for two frames
6. ZBTISI mode is enabled (RCR2.6 = 1)
7. RLINK data (Z bits) is updated one bit time before odd frames and held for four frames
8. RLINK and RLCLK are not synchronous with RSYNC when the receive side elastic store is enabled

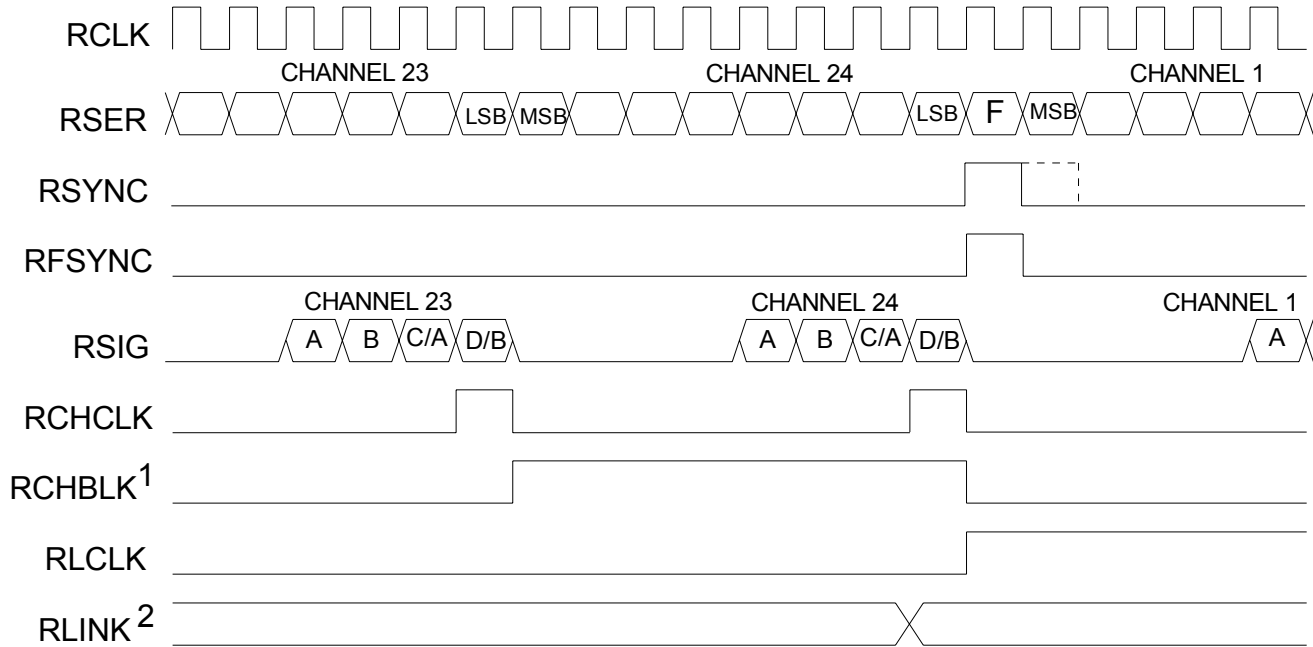
**Figure 21-3 RECEIVE SIDE BOUNDARY TIMING (with elastic store disabled)****Notes:**

1. RCHBLK is programmed to block channel 24
2. Shown is RLINK/RLCLK in the ESF framing mode

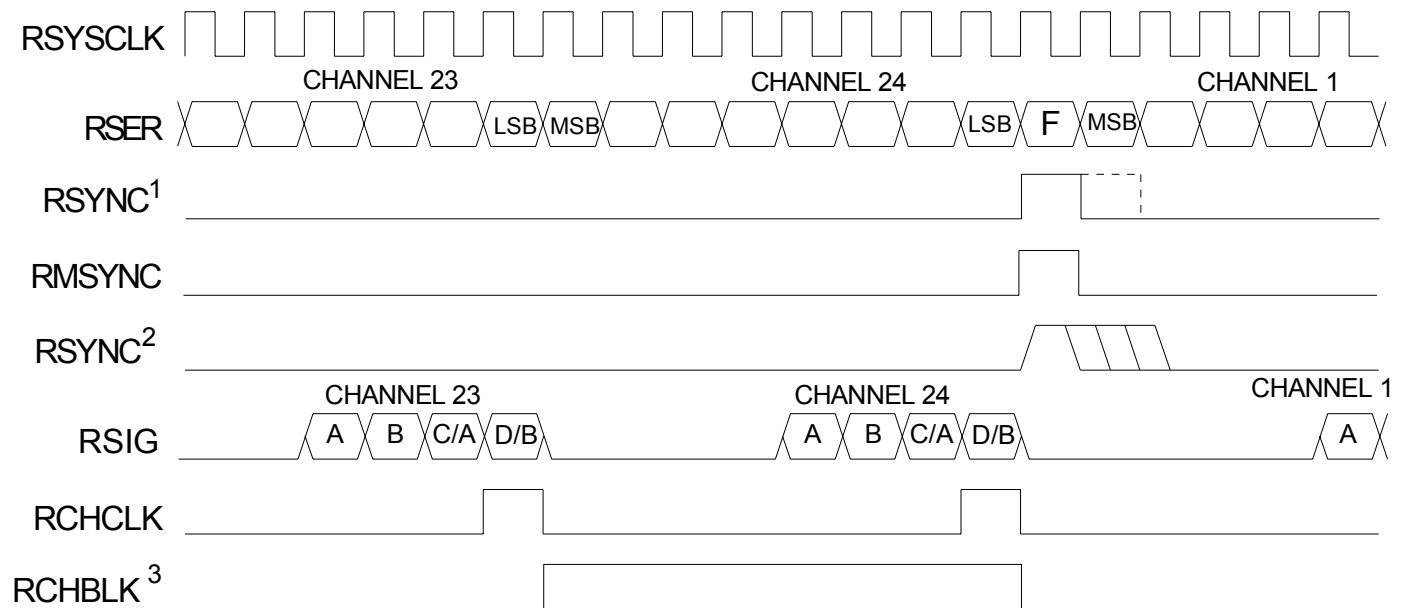
**Figure 21-4 RECEIVE SIDE 1.544 MHz BOUNDARY TIMING (with elastic store enabled)****Notes:**

1. RSYNC is in the output mode (RCR2.3 = 0)
2. RSYNC is in the input mode (RCR2.3 = 1)
3. RCHBLK is programmed to block channel 24

## Figure 21-5 RECEIVE SIDE 2.048 MHz BOUNDARY TIMING (with elastic store enabled)

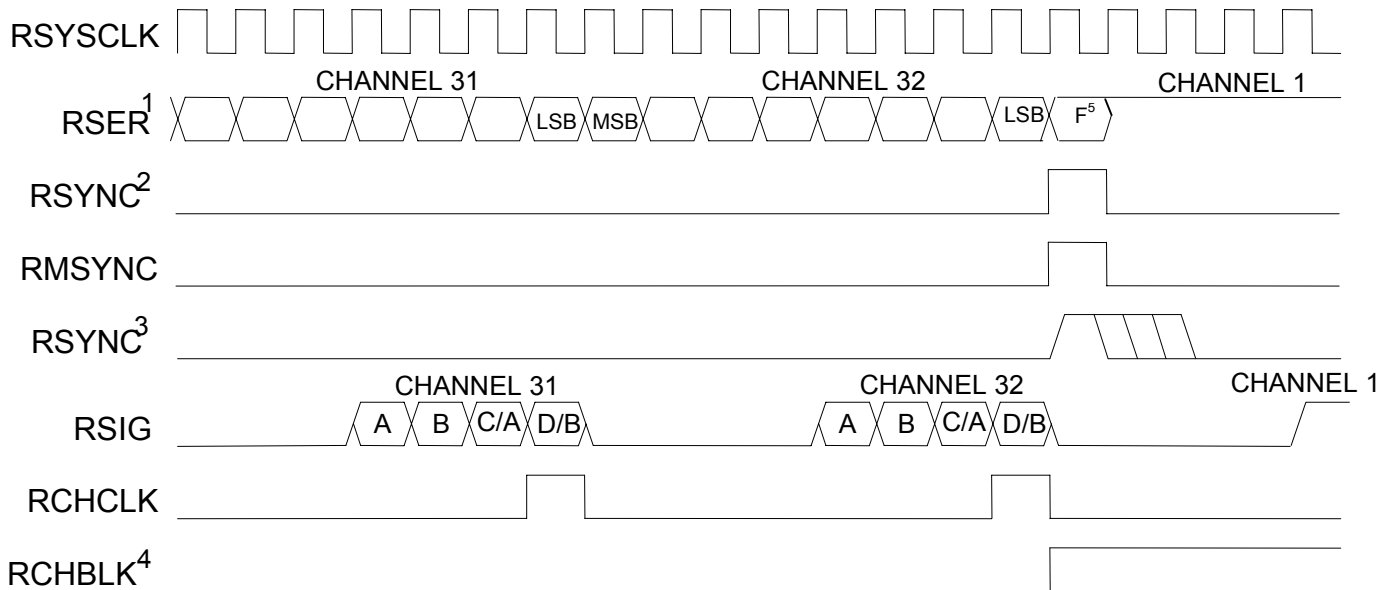

### Notes:

1. RSER data in channels 1, 5, 9, 13, 17, 21, 25, and 29 are forced to one
2. RSYNC is in the output mode (RCR2.3 = 0)
3. RSYNC is in the input mode (RCR2.3 = 1)
4. RCHBLK is forced to one in the same channels as RSER (see Note 1)
5. The F-Bit position is passed through the receive side elastic store



## Figure 21-6 RECEIVE SIDE INTERLEAVE BUS OPERATION, BYTE MODE

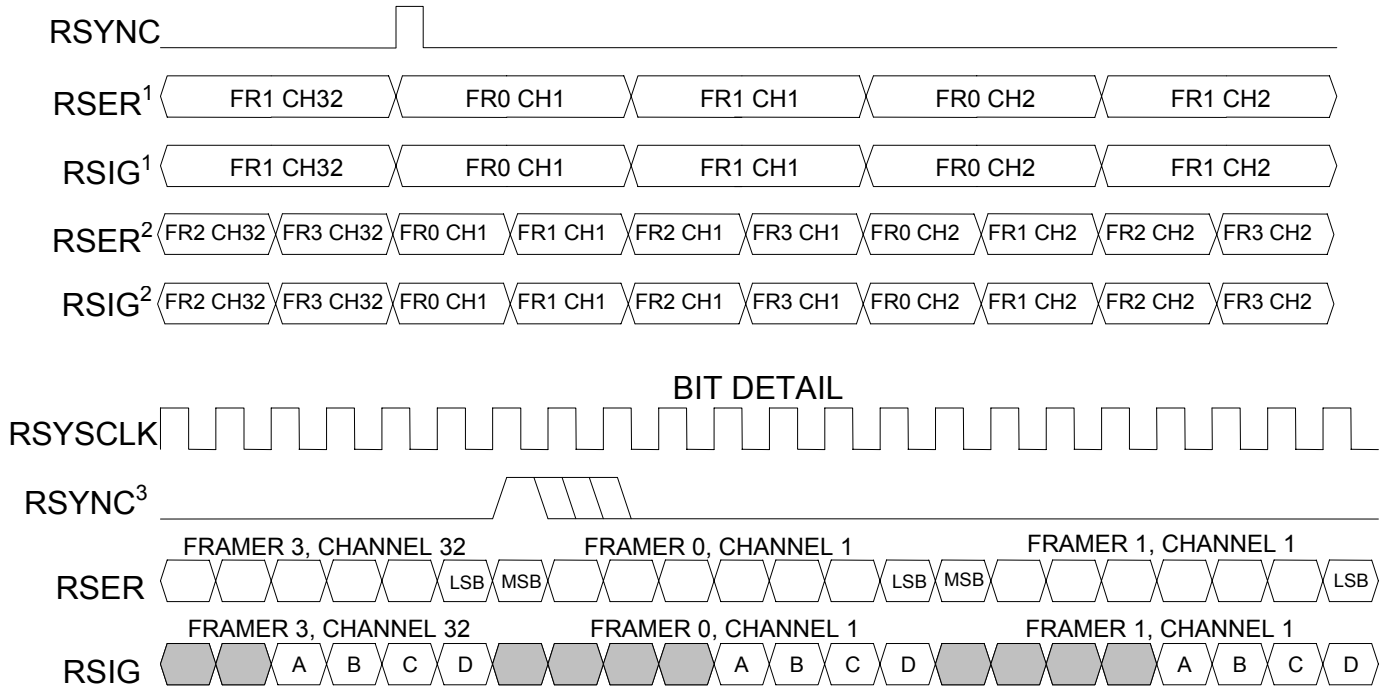

### Notes:

1. 4.096 MHz bus configuration.
2. 8.192 MHz bus configuration.
3. RSYNC is in the input mode (RCR1.5 = 0)

**Figure 21-7 RECEIVE SIDE INTERLEAVE BUS OPERATION, FRAME MODE**

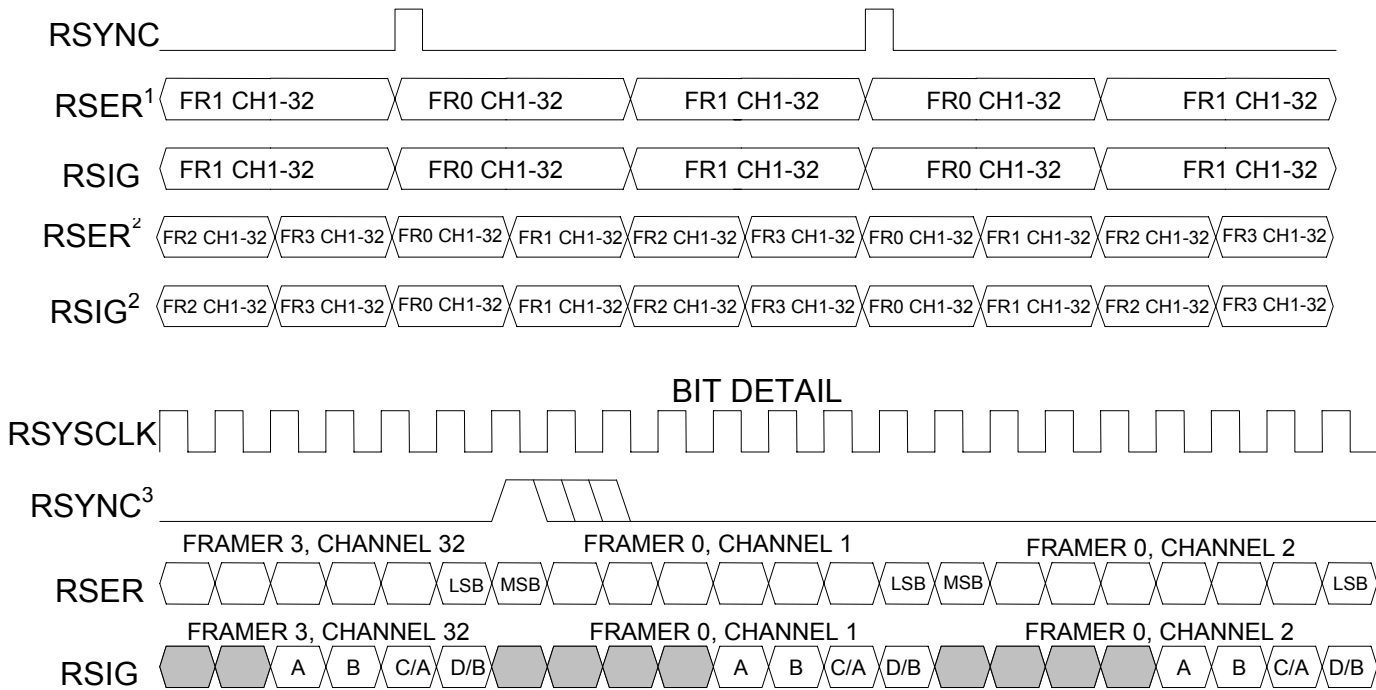

**Notes:**

1. 4.096 MHz bus configuration.
2. 8.192 MHz bus configuration.
3. RSYNC is in the input mode (RCR1.5 = 0).

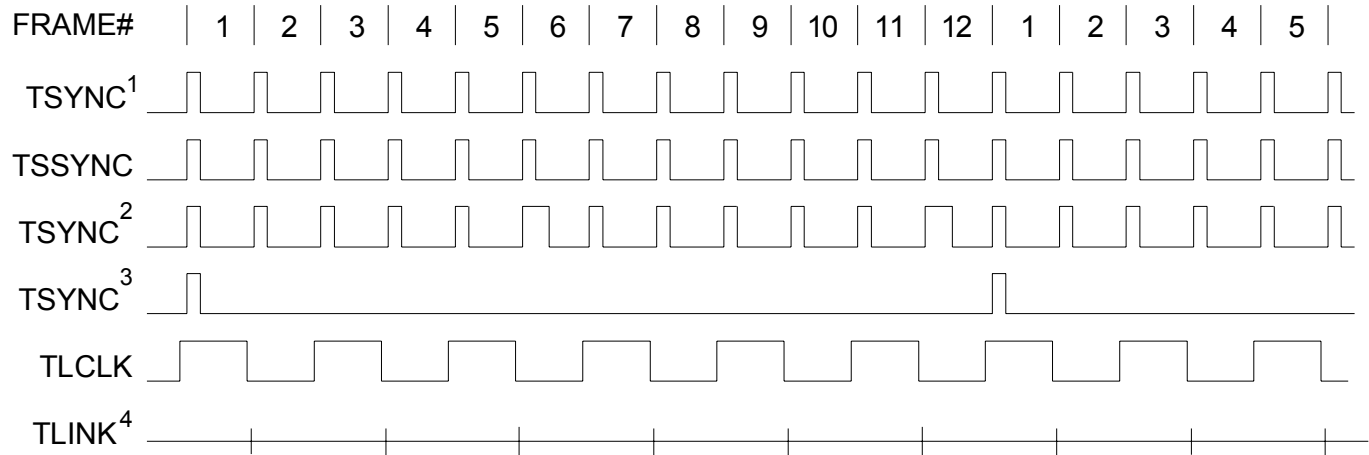
**Figure 21-8 TRANSMIT SIDE D4 TIMING****Notes:**

1. TSYNC in the frame mode (TCR2.3 = 0) and double-wide frame sync is not enabled (TCR2.4 = 0)
2. TSYNC in the frame mode (TCR2.3 = 0) and double-wide frame sync is enabled (TCR2.4 = 1)
3. TSYNC in the multiframe mode (TCR2.3 = 1)
4. TLINK data (Fs - bits) sampled during the F-bit position of even frames for insertion into the outgoing T1 stream when enabled via TCR1.2
5. TLINK and TLCLK are not synchronous with TSSYNC

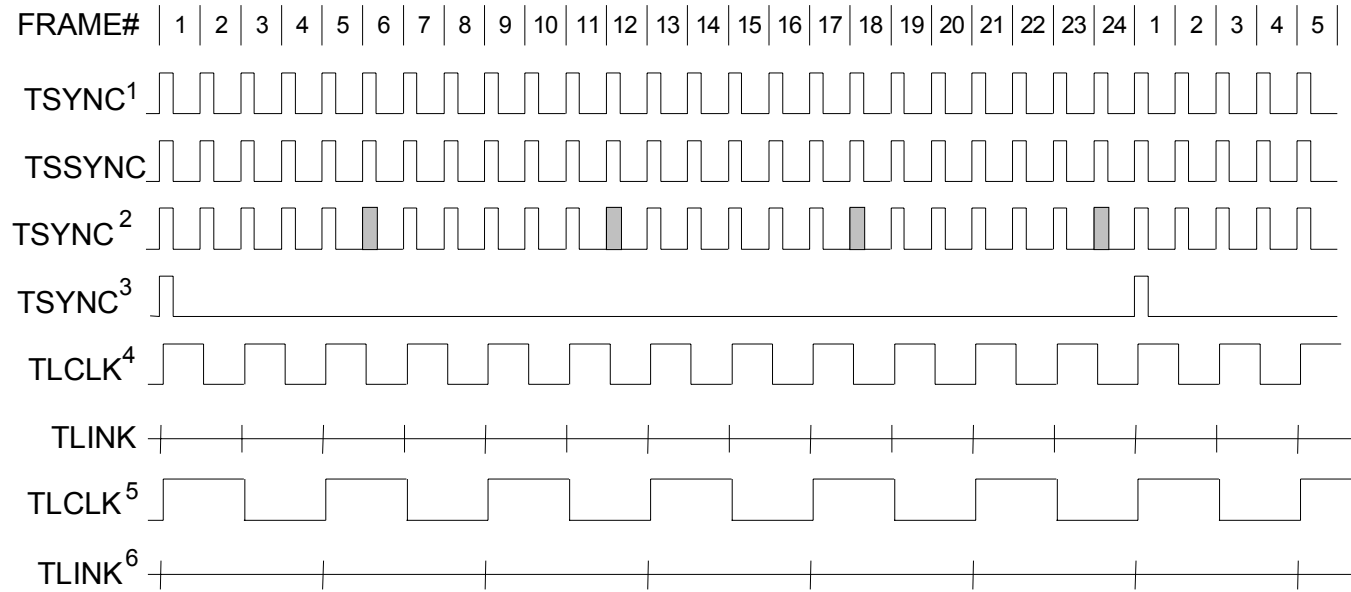
**Figure 21-9 TRANSMIT SIDE ESF TIMING****Notes:**

1. TSYNC in frame mode (TCR2.3 = 0) and double-wide frame sync is not enabled (TCR2.4 = 0)
2. TSYNC in frame mode (TCR2.3 = 0) and double-wide frame sync is enabled (TCR2.4 = 1)
3. TSYNC in multiframe mode (TCR2.3 = 1)
4. TLINK data (FDL bits) sampled during the F-bit time of odd frame and inserted into the outgoing T1 stream if enabled via TCR1.2
5. ZBTSI mode is enabled (TCR2.5 = 1)
6. TLINK data (Z bits) sampled during the F-bit time of frames 1, 5, 9, 13, 17, and 21 and inserted into the outgoing stream if enabled via TCR1.2
7. TLINK and TLCLK are not synchronous with TSSYNC

**Figure 21-10 TRANSMIT SIDE BOUNDARY TIMING (with elastic store disabled)**

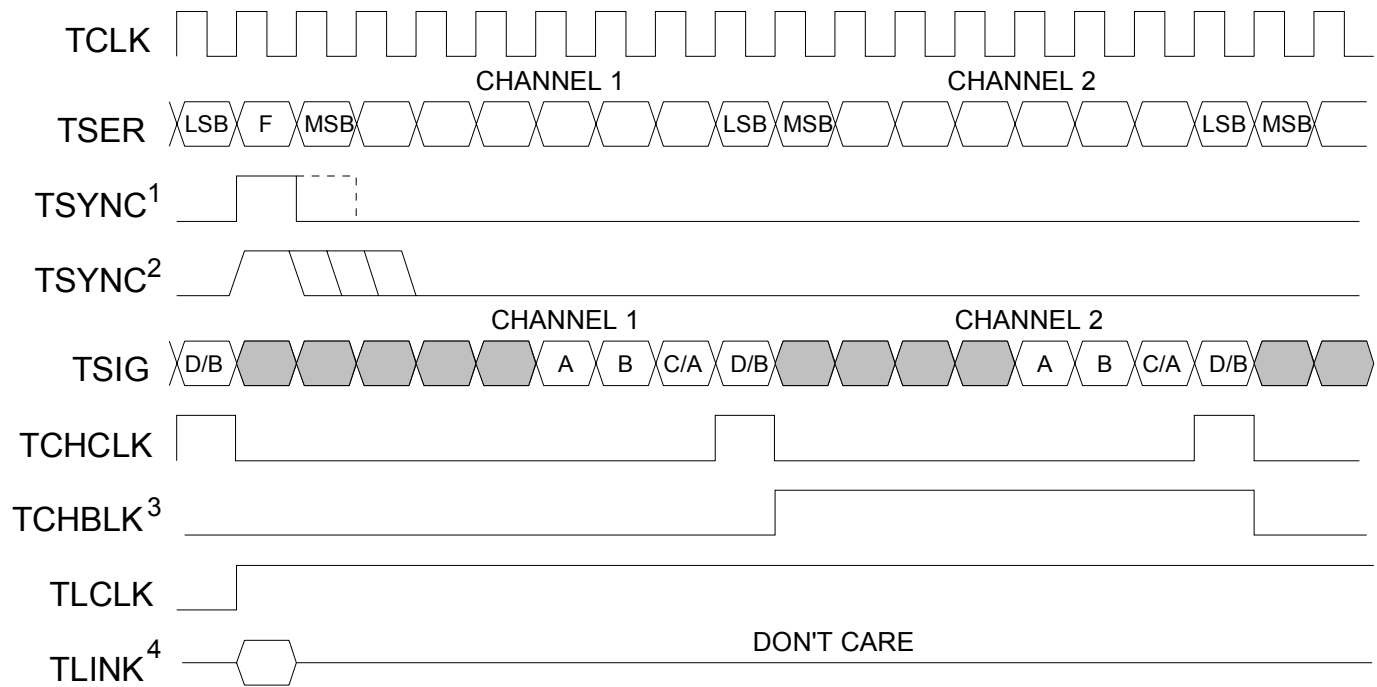

**Notes:**

1. TSYNC is in the output mode (TCR2.2 = 1)
2. TSYNC is in the input mode (TCR2.2 = 0)
3. TCHBLK is programmed to block channel 2
4. Shown is TLINK/TLCLK in the ESF framing mode

**Figure 21-11 TRANSMIT SIDE 1.544 MHz BOUNDARY TIMING (with elastic store enabled)**

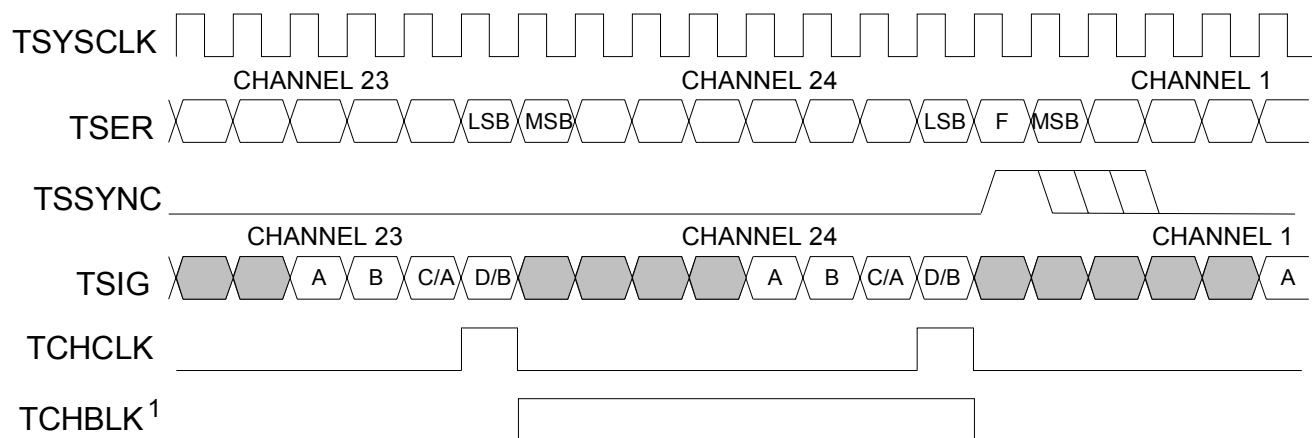

**Notes:**

1. TCHBLK is programmed to block channel 24 (if the TPCSI bit is set, then the signaling data at TSIG will be ignored during channel 24).

**Figure 21-12 TRANSMIT SIDE 2.048 MHz BOUNDARY TIMING (with elastic store enabled)**

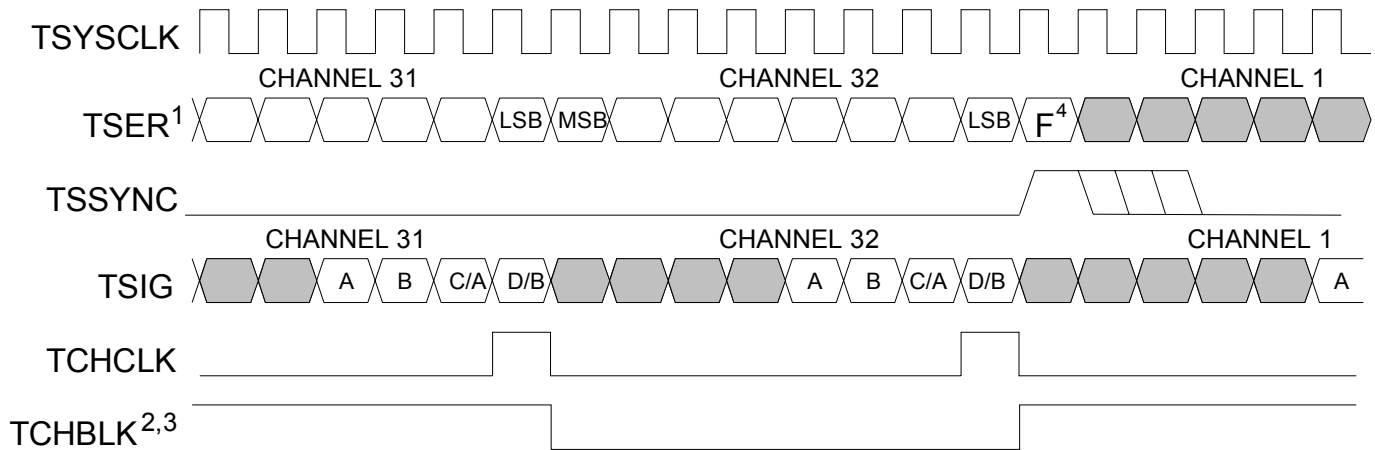

**Notes:**

1. TSER data in channels 1, 5, 9, 13, 17, 21, 25, and 29 is ignored
2. TCHBLK is programmed to block channel 31 (if the TPCSI bit is set, then the signaling data at TSIG will be ignored).
3. TCHBLK is forced to one in the same channels as TSER is ignored (see Note 1)
4. The F-bit position for the T1 frame is sampled and passed through the transmit side elastic store into the MSB bit position of channel 1. (normally the transmit side formatter overwrites the F-bit position unless the formatter is programmed to pass-through the F-bit position)

**Figure 21-13 TRANSMIT SIDE INTERLEAVE BUS OPERATION, BYTE MODE**

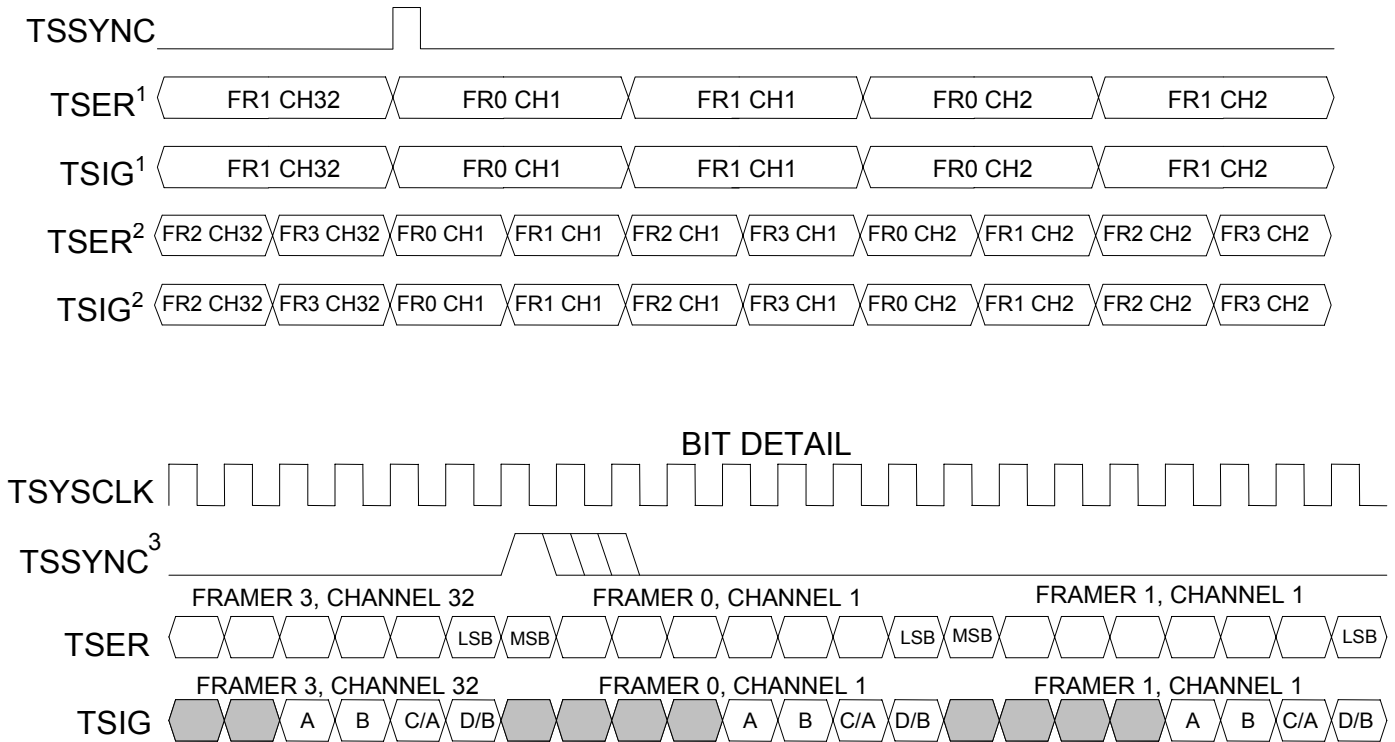

**Notes:**

1. 4.096 MHz bus configuration.
2. 8.192 MHz bus configuration.

### Figure 21-14 TRANSMIT INTERLEAVE BUS OPERATION, FRAME MODE

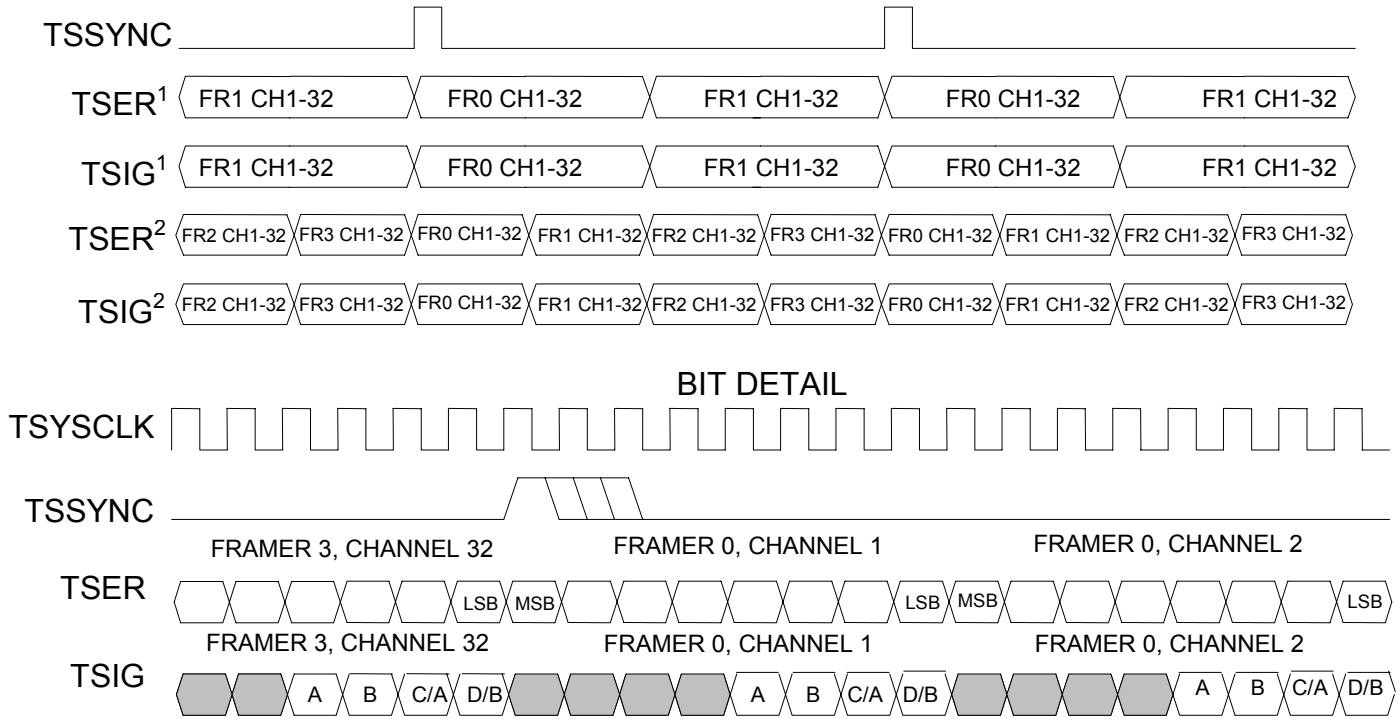

**Notes:**

1. 4.096 MHz bus configuration.
2. 8.192 MHz bus configuration.



## 22. RECEIVE AND TRANSMIT DATA FLOW DIAGRAMS

Figure 22-1 RECEIVE DATA FLOW

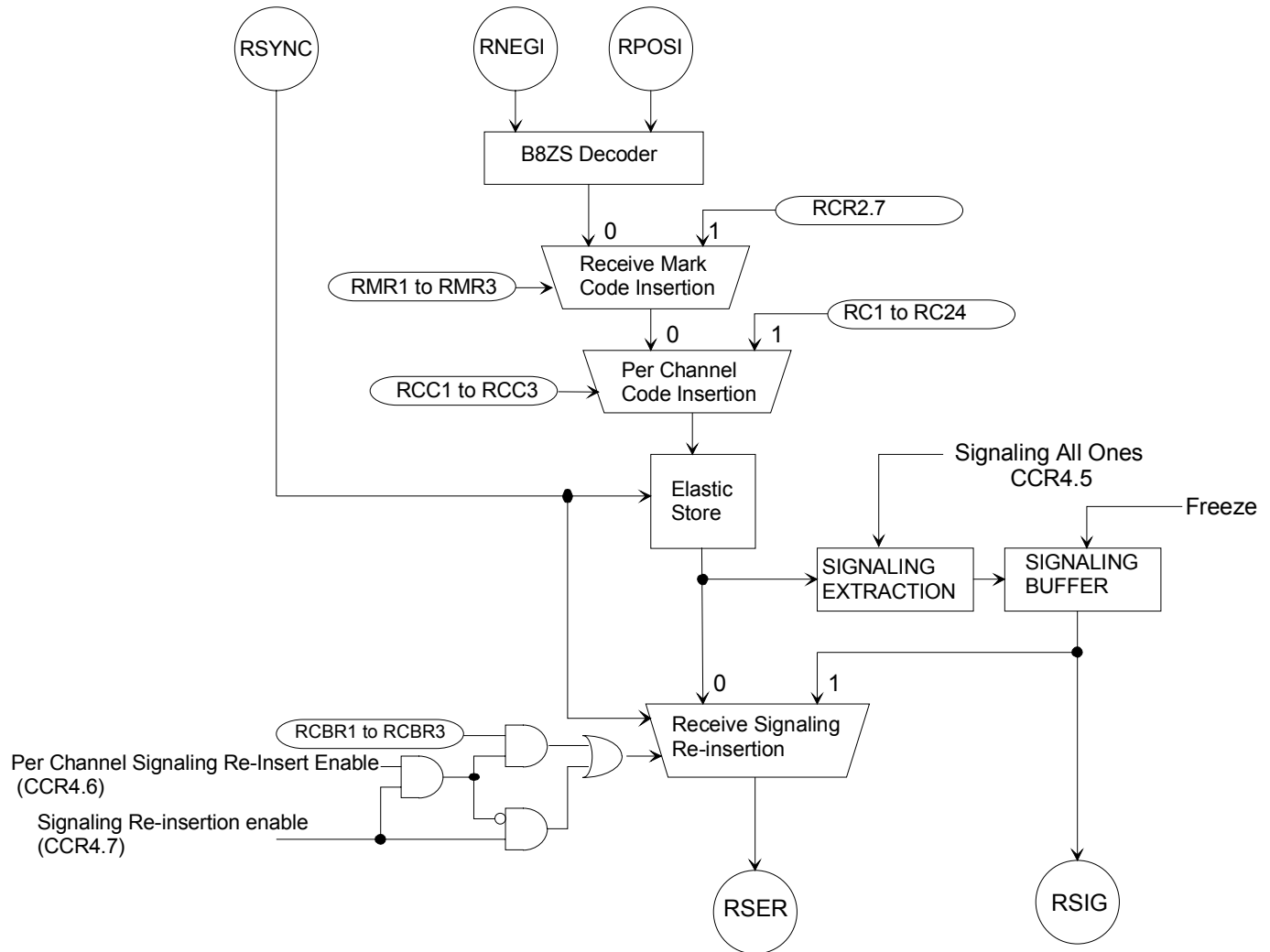

**Figure 22-2 TRANSMIT DATA FLOW**

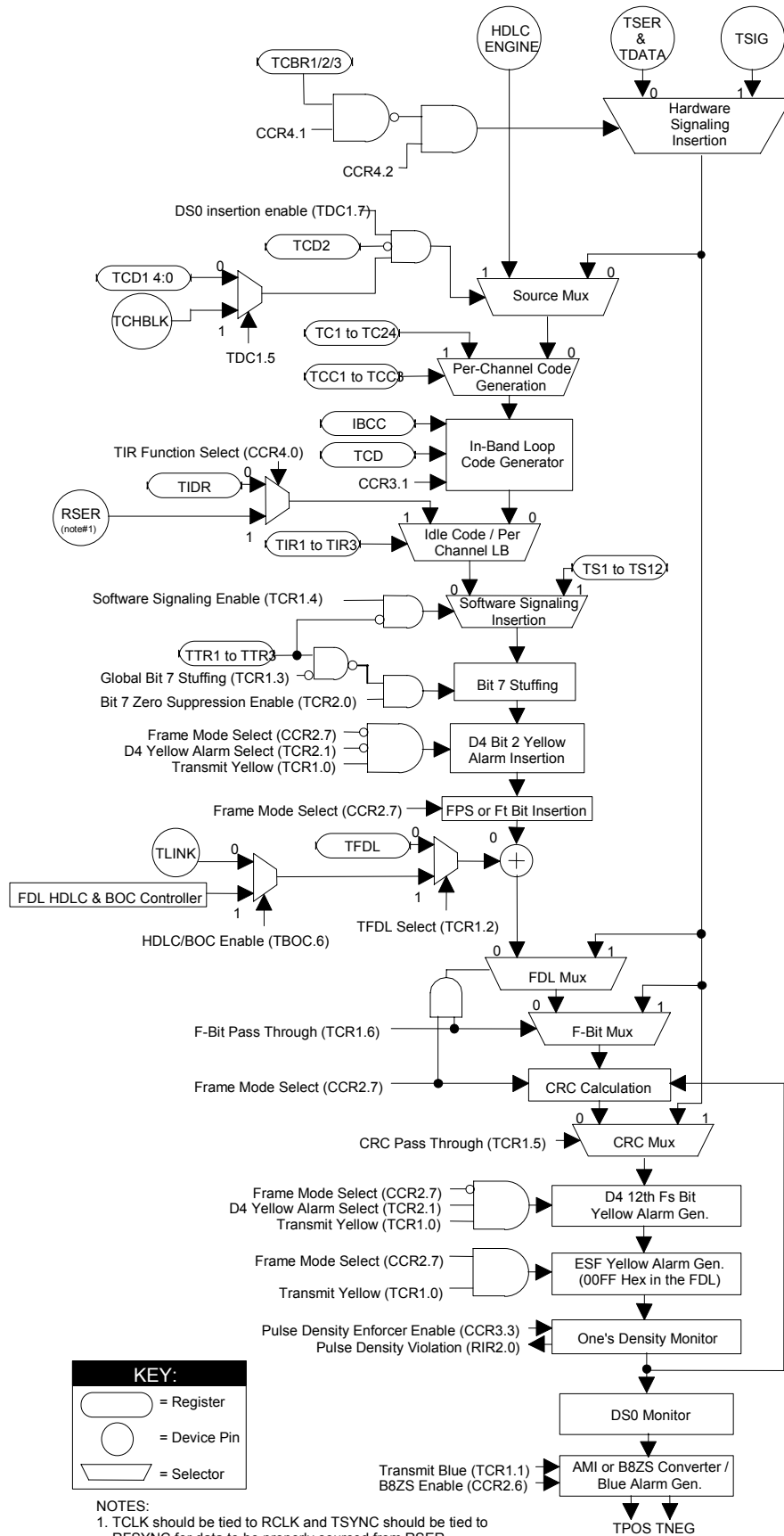

## 23. OPERATING PARAMETERS

### ABSOLUTE MAXIMUM RATINGS\*

Voltage on Any Pin Relative to Ground	-1.0V to +6.0V
Operating Temperature for DS21352L/DS21552L	0°C to 70°C
Operating Temperature for DS21352LN/DS21552LN	-40°C to +85°C
Storage Temperature	-55°C to +125°C
Soldering Temperature	260°C for 10 seconds

\* This is a stress rating only and functional operation of the device at these or any other conditions above those indicated in the operation sections of this specification is not implied. Exposure to absolute maximum rating conditions for extended periods of time may affect reliability.

### RECOMMENDED DC OPERATING CONDITIONS

(0°C to 70°C for DS21352L/DS21552L;  
-40°C to +85°C for DS21352LN/DS21552LN)

PARAMETER	SYMBOL	MIN	TYP	MAX	UNITS	NOTES
Logic 1	$V_{IH}$	2.0		5.5	V	
Logic 0	$V_{IL}$	-0.3		+0.8	V	
Supply for DS21352	$V_{DD}$	3.135	3.3	3.465	V	1
Supply for DS21552	$V_{DD}$	4.75	5	5.25	V	1

### CAPACITANCE

( $t_A = 25^\circ\text{C}$ )

PARAMETER	SYMBOL	MIN	TYP	MAX	UNITS	NOTES
Input Capacitance	$C_{IN}$		5		pF	
Output Capacitance	$C_{OUT}$		7		pF	

### DC CHARACTERISTICS

(0°C to 70°C;  $V_{DD} = 3.3\text{V} \pm 5\%$  for DS21352L;  
0°C to 70°C;  $V_{DD} = 5.0\text{V} \pm 5\%$  for DS21552L;  
-40°C to +85°C;  $V_{DD} = 3.3\text{V} \pm 5\%$  for DS21352LN;  
-40°C to +85°C;  $V_{DD} = 5.0\text{V} \pm 5\%$  for DS21552LN)

PARAMETER	SYMBOL	MIN	TYP	MAX	UNITS	NOTES
Supply Current @ 5V	$I_{DD}$		75		mA	2
Supply Current @ 3.3V	$I_{DD}$		75		mA	2
Input Leakage	$I_{IL}$	-1.0		+1.0	$\mu\text{A}$	3
Output Leakage	$I_{LO}$			1.0	$\mu\text{A}$	4
Output Current (2.4V)	$I_{OH}$	-1.0			mA	
Output Current (0.4V)	$I_{OL}$	+4.0			mA	

### NOTES:

- Applies to RVDD, TVDD, and DVDD.
- TCLK = TCLKI = RCLKI = TSYSCCLK = RSYSCCLK = MCLK = 1.544 MHz; outputs open circuited.
- $0.0\text{V} < V_{IN} < V_{DD}$ .
- Applied to INT\* when 3-stated.

## 24. AC TIMING PARAMETERS AND DIAGRAMS

### 24.1 MULTIPLEXED BUS AC CHARACTERISTICS

AC CHARACTERISTICS –  
MULTIPLEXED PARALLEL PORT  
(MUX = 1)

[See Figure 24-1 to Figure 24-3]

(0°C to 70°C;  $V_{DD} = 3.3V \pm 5\%$  for DS21352L;  
0°C to 70°C;  $V_{DD} = 5.0V \pm 5\%$  for DS21552L;  
-40°C to +85°C;  $V_{DD} = 3.3V \pm 5\%$  for DS21352LN;  
-40°C to +85°C;  $V_{DD} = 5.0V \pm 5\%$  for DS21552LN)

PARAMETER	SYMBOL	MIN	TYP	MAX	UNITS	NOTES
Cycle Time	$t_{CYC}$	200			ns	
Pulse Width, DS low or RD* high	$PW_{EL}$	100			ns	
Pulse Width, DS high or RD* low	$PW_{EH}$	100			ns	
Input Rise/Fall times	$t_R, t_F$			20	ns	
R/W* Hold Time	$t_{RWH}$	10			ns	
R/W* Set Up time before DS high	$t_{RWS}$	50			ns	
CS* Set Up time before DS, WR* or RD* active	$t_{CS}$	20			ns	
CS* Hold time	$t_{CH}$	0			ns	
Read Data Hold time	$t_{DHR}$	10		50	ns	
Write Data Hold time	$t_{DHW}$	0			ns	
Muxed Address valid to AS or ALE fall	$t_{ASL}$	15			ns	
Muxed Address Hold time	$t_{AHL}$	10			ns	
Delay time DS, WR* or RD* to AS or ALE rise	$t_{ASD}$	20			ns	
Pulse Width AS or ALE high	$PW_{ASH}$	30			ns	
Delay time, AS or ALE to DS, WR* or RD*	$t_{ASED}$	10			ns	
Output Data Delay time from DS or RD*	$t_{DDR}$	20		80	ns	
Data Set Up time	$t_{DSW}$	50			ns	

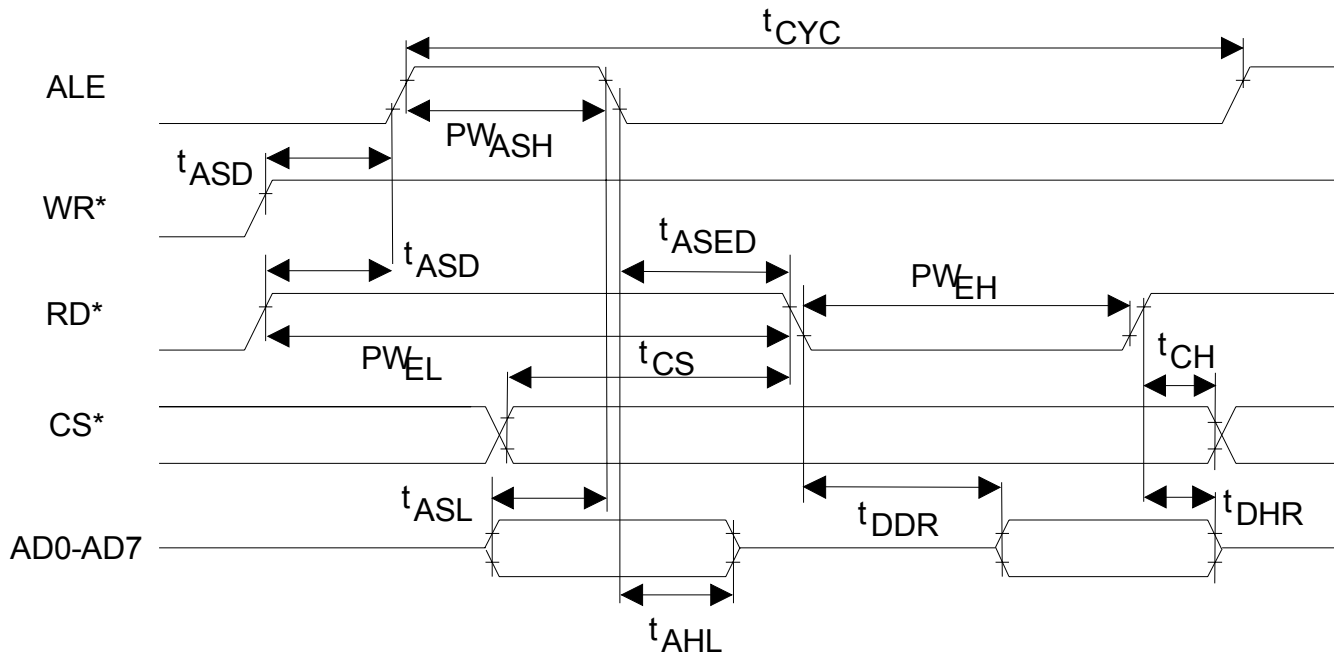
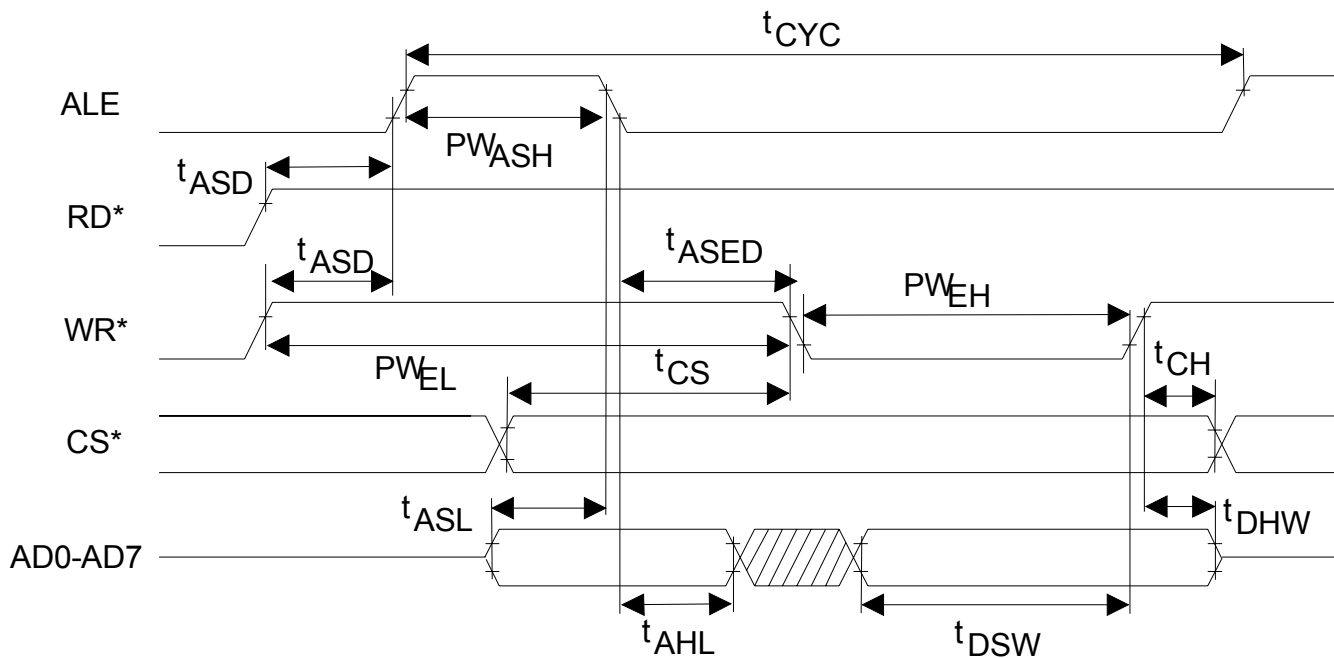
**Figure 24-1 INTEL BUS READ TIMING (BTS=0 / MUX = 1)****Figure 24-2 INTEL BUS WRITE TIMING (BTS=0 / MUX=1)**



## 24.2 NON-MULTIPLEXED BUS AC CHARACTERISTICS

### AC CHARACTERISTICS – NON-MULTIPLEXED PARALLEL PORT (MUX = 0)

[See Figure 24-4 to Figure 24-7]

(0°C to 70°C;  $V_{DD} = 3.3V \pm 5\%$  for DS21352L;  
0°C to 70°C;  $V_{DD} = 5.0V \pm 5\%$  for DS21552L;  
-40°C to +85°C;  $V_{DD} = 3.3V \pm 5\%$  for DS21352LN;  
-40°C to +85°C;  $V_{DD} = 5.0V \pm 5\%$  for DS21552LN)

PARAMETER	SYMBOL	MIN	TYP	MAX	UNITS	NOTES
Set Up Time for A0 to A7, Valid to CS* Active	t1	0			ns	
Set Up Time for CS* Active to either RD*, WR*, or DS* Active	t2	0			ns	
Delay Time from either RD* or DS* Active to Data Valid	t3			75	ns	
Hold Time from either RD*, WR*, or DS* Inactive to CS* Inactive	t4	0			ns	
Hold Time from CS* Inactive to Data Bus 3–state	t5	5		20	ns	
Wait Time from either WR* or DS* Active to Latch Data	t6	75			ns	
Data Set Up Time to either WR* or DS* Inactive	t7	10			ns	
Data Hold Time from either WR* or DS* Inactive	t8	10			ns	
Address Hold from either WR* or DS* inactive	t9	10			ns	

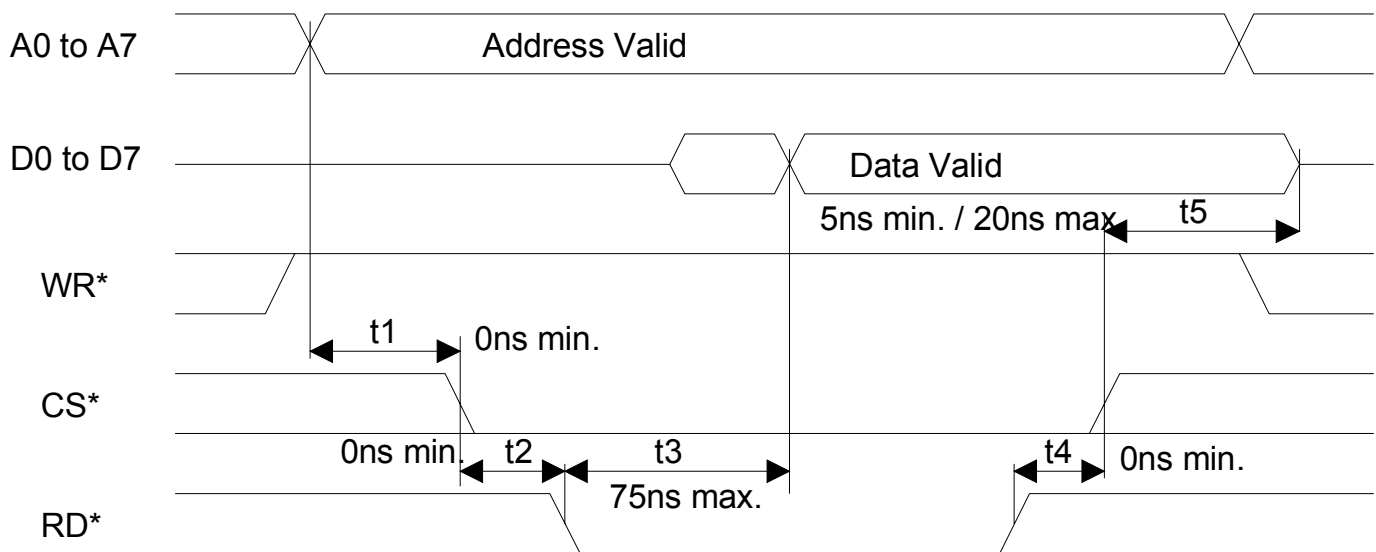
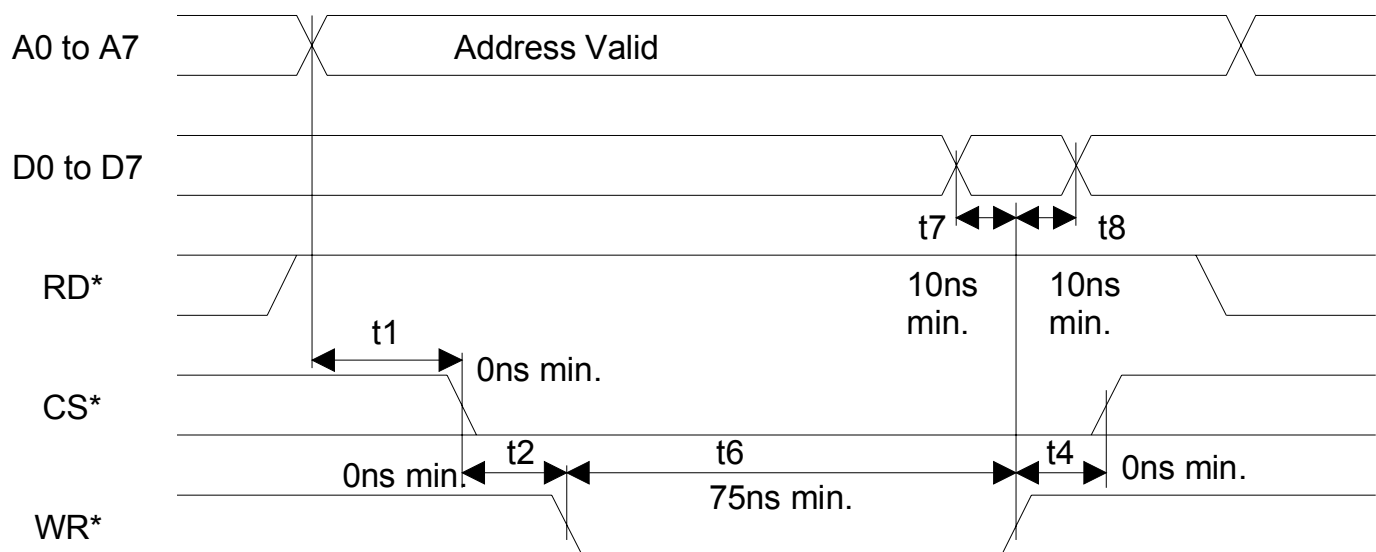
**Figure 24-4 INTEL BUS READ TIMING (BTS=0 / MUX=0)****Figure 24-5 INTEL BUS WRITE TIMING (BTS=0 / MUX=0)**

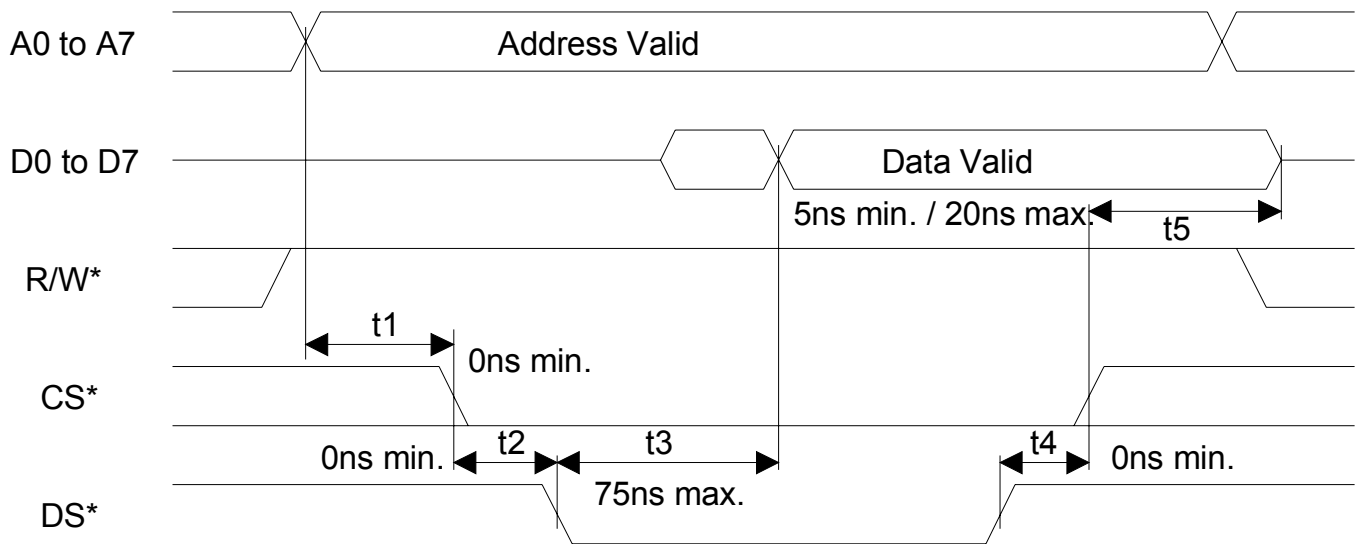
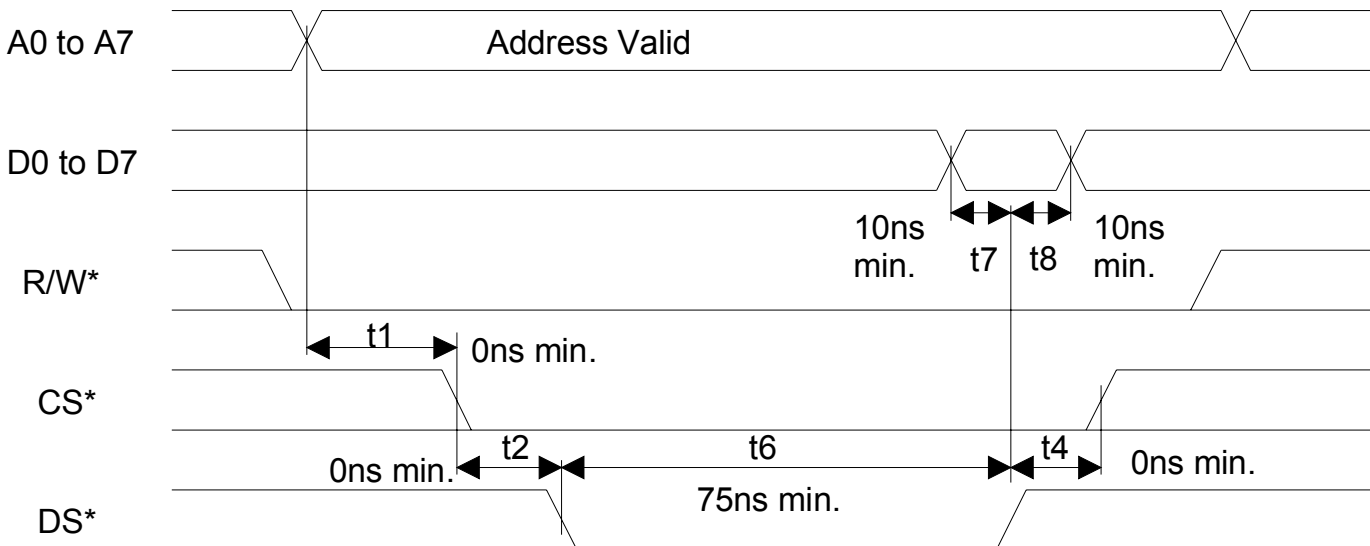

**Figure 24-6 MOTOROLA BUS READ TIMING (BTS=1 / MUX=0)****Figure 24-7 MOTOROLA BUS WRITE TIMING (BTS=1 / MUX=0)**

## 24.3 RECEIVE SIDE AC CHARACTERISTICS

### AC CHARACTERISTICS – RECEIVE SIDE

(0°C to 70°C;  $V_{DD} = 3.3V \pm 5\%$  for DS21352L;  
0°C to 70°C;  $V_{DD} = 5.0V \pm 5\%$  for DS21552L;  
-40°C to +85°C;  $V_{DD} = 3.3V \pm 5\%$  for DS21352LN;  
-40°C to +85°C;  $V_{DD} = 5.0V \pm 5\%$  for DS21552LN)

[See Figure 24-8 to Figure 24-10]

PARAMETER	SYMBOL	MIN	TYP	MAX	UNITS	NOTES
RCLKO Period	$t_{LP}$		648		ns	
RCLKO Pulse Width	$t_{LH}$	200	324		ns	1
	$t_{LL}$	200	324		ns	1
RCLKO Pulse Width	$t_{LH}$	150	324		ns	2
	$t_{LL}$	150	324		ns	2
RCLKI Period	$t_{CP}$		648		ns	
RCLKI Pulse Width	$t_{CH}$	75			ns	
	$t_{CL}$	75			ns	
RSYSCLK Period	$t_{SP}$	100	648		ns	3
	$t_{SP}$	100	488		ns	4
	$t_{SP}$	100	244		ns	5
	$t_{SP}$	100	122		ns	6
RSYSCLK Pulse Width	$t_{SH}$	50			ns	
	$t_{SL}$	50			ns	
RSYNC Set Up to RSYSCLK Falling	$t_{SU}$	20		$t_{SH} - 5$	ns	
RSYNC Pulse Width	$t_{PW}$	50			ns	
RPOSI/RNEGI Set Up to RCLKI Falling	$t_{SU}$	20			ns	
RPOSI/RNEGI Hold From RCLKI Falling	$t_{HD}$	20			ns	
RSYSCLK/RCLKI Rise and Fall Times	$t_R, t_F$			25	ns	
Delay RCLKO to RPOSO, RNEGO Valid	$t_{DD}$			50	ns	
Delay RCLK to RSER, RDATA, RSIG, RLINK Valid	$t_{D1}$			50	ns	
Delay RCLK to RCHCLK, RSYNC, RCHBLK, RFSYNC, RLCLK	$t_{D2}$			50	ns	
Delay RSYSCLK to RSER, RSIG Valid	$t_{D3}$			50	ns	
Delay RSYSCLK to RCHCLK, RCHBLK, RMSYNC, RSYNC, CO	$t_{D4}$			50	ns	
CI Set Up to RSYSCLK Rising	$t_{SC}$	20			ns	
CI Pulse Width	$t_{WC}$	50			ns	

### NOTES:

- Jitter attenuator enabled in the receive path.
- Jitter attenuator disabled or enabled in the transmit path.
- RSYSCLK = 1.544 MHz.
- RSYSCLK = 2.048 MHz.
- RSYSCLK = 4.096 MHz
- RSYSCLK = 8.192 MHz

### Figure24-8 RECEIVE SIDE TIMING

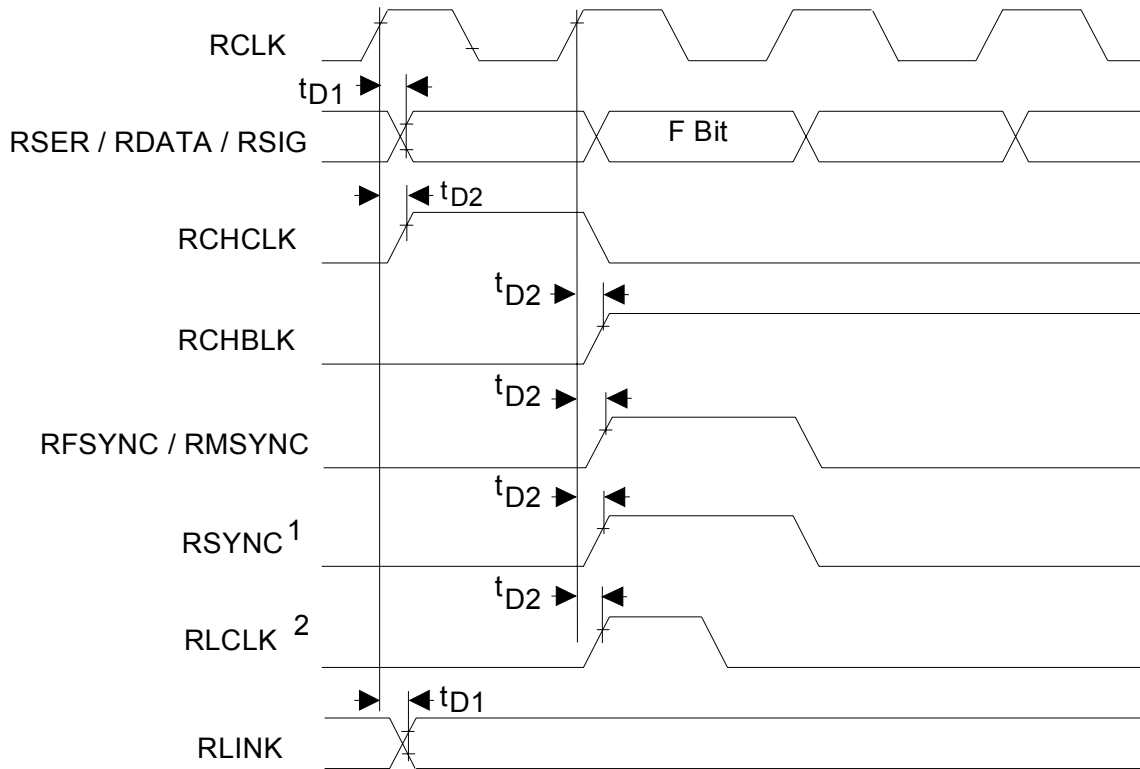

## Notes:

1. RSYNC is in the output mode (RCR2.3 = 0).
2. Shown is RLINK/RLCLK in the ESF framing mode
3. No Relationship between RCHCLK and RCHBLK and other signals is implied

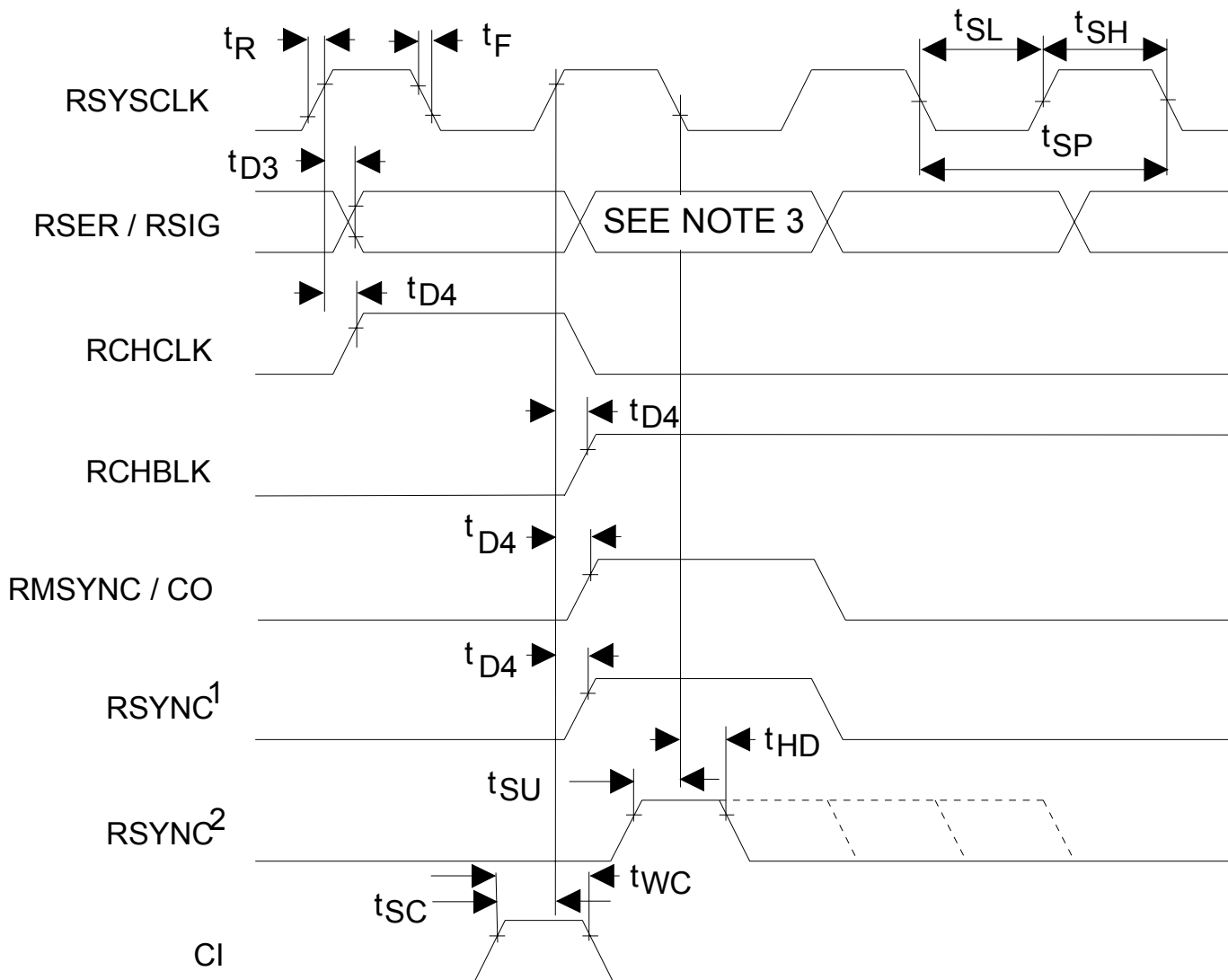
**Figure 24.9 RECEIVE SIDE TIMING, ELASTIC STORE ENABLED**

## Notes:

1. RSYNC is in the output mode (RCR2.3 = 0)
2. RSYNC is in the input mode (RCR2.3 = 1)
3. F-BIT when CCR1.3 = 0, MSB of TS0 when CCR1.3 = 1

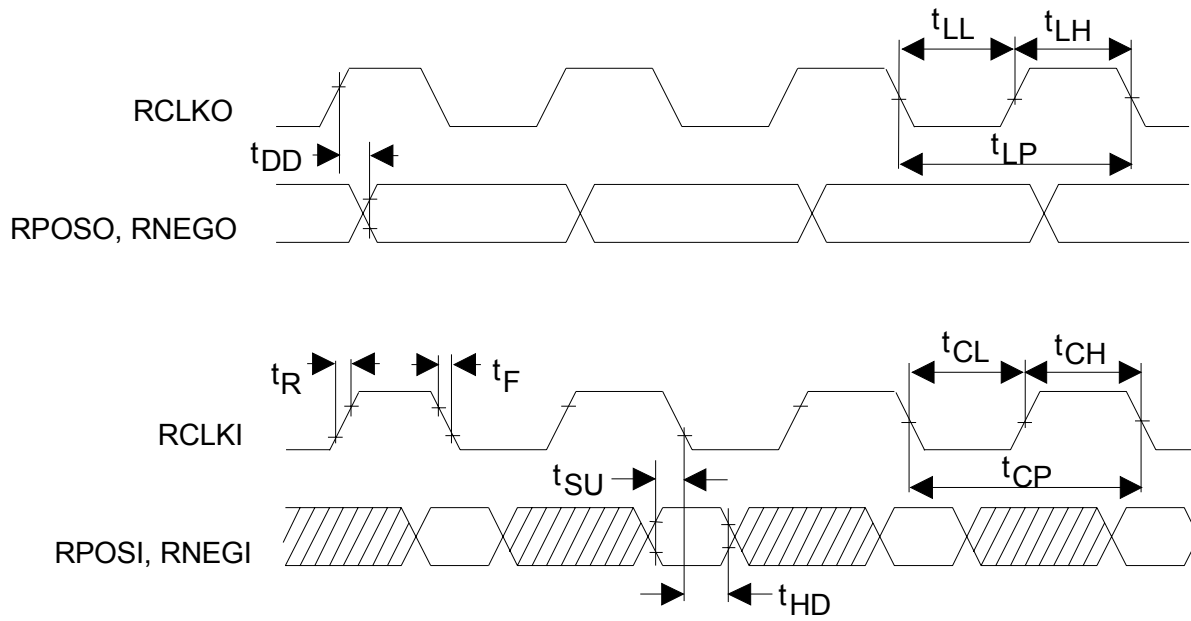
**Figure 24-10 RECEIVE LINE INTERFACE TIMING**

## 24.4 TRANSMIT AC CHARACTERISTICS

### AC CHARACTERISTICS – TRANSMIT SIDE

(0°C to 70°C;  $V_{DD} = 3.3V \pm 5\%$  for DS21352L;  
0°C to 70°C;  $V_{DD} = 5.0V \pm 5\%$  for DS21552L;  
-40°C to +85°C;  $V_{DD} = 3.3V \pm 5\%$  for DS21352LN;  
-40°C to +85°C;  $V_{DD} = 5.0V \pm 5\%$  for DS21552LN)

[See Figure 24-11 to Figure 24-13]

PARAMETER	SYMBOL	MIN	TYP	MAX	UNITS	NOTES
TCLK Period	$t_{CP}$		648		ns	
TCLK Pulse Width	$t_{CH}$	75			ns	
	$t_{CL}$	75			ns	
TCLKI Period	$t_{LP}$		648		ns	
TCLKI Pulse Width	$t_{LH}$	75			ns	
	$t_{LL}$	75			ns	
TSYSCLK Period	$t_{SP}$	100	648		ns	1
	$t_{SP}$	100	488		ns	2
	$t_{SP}$	100	244		ns	3
	$t_{SP}$	100	122		ns	4
TSYSCLK Pulse Width	$t_{SH}$	50			ns	
	$t_{SL}$	50			ns	
TSYNC or TSSYNC Set Up to TCLK or TSYSCLK falling	$t_{SU}$	20		$t_{CH} - 5$ or $t_{SH} - 5$	ns	
TSYNC or TSSYNC Pulse Width	$t_{PW}$	50			ns	
TSER, TSIG, TDATA, TLINK, TPOSI, TNEGI Set Up to TCLK, TSYSCLK, TCLKI Falling	$t_{SU}$	20			ns	
TSER, TSIG, TDATA, TLINK, TPOSI, TNEGI Hold from TCLK, TSYSCLK, TCLKI Falling	$t_{HD}$	20			ns	
TCLK, TCLKI or TSYSCLK Rise and Fall Times	$t_R, t_F$			25	ns	
Delay TCLKO to TPOSO, TNEGO Valid	$t_{DD}$			50	ns	
Delay TCLK to TESO Valid	$t_{D1}$			50	ns	
Delay TCLK to TCHBLK, TCHCLK, TSYNC, TLCLK	$t_{D2}$			50	ns	
Delay TSYSCLK to TCHCLK, TCHBLK, CO	$t_{D3}$			75	ns	
CI Set Up to TSYSCLK Rising	$t_{SC}$	20			ns	
CI Pulse Width	$t_{WC}$	50			ns	

### NOTES:

1. TSYSCLK = 1.544 MHz.
2. TSYSCLK = 2.048 MHz.
3. TSYSCLK = 4.096 MHz
4. TSYSCLK = 8.192 MHz

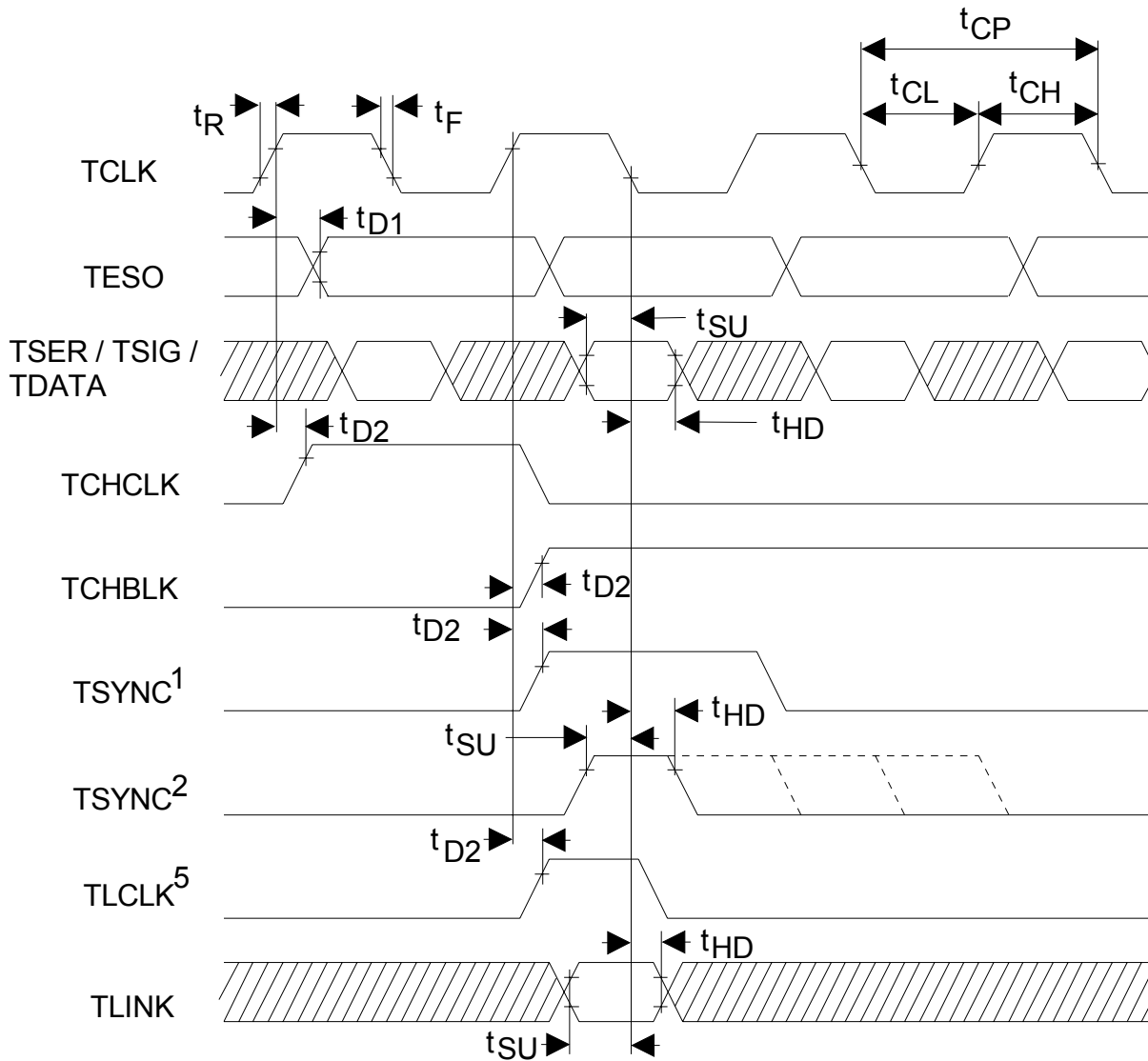
**Figure 24-11 TRANSMIT SIDE TIMING****Notes:**

1. TSYNC is in the output mode (TCR2.2 = 1).
2. TSYNC is in the input mode (TCR2.2 = 0).
3. TSER is sampled on the falling edge of TCLK when the transmit side elastic store is disabled.
4. TCHCLK and TCHBLK are synchronous with TCLK when the transmit side elastic store is disabled.
5. TLINK is only sampled during F-bit locations.
6. No relationship between TCHCLK and TCHBLK and the other signals is implied.

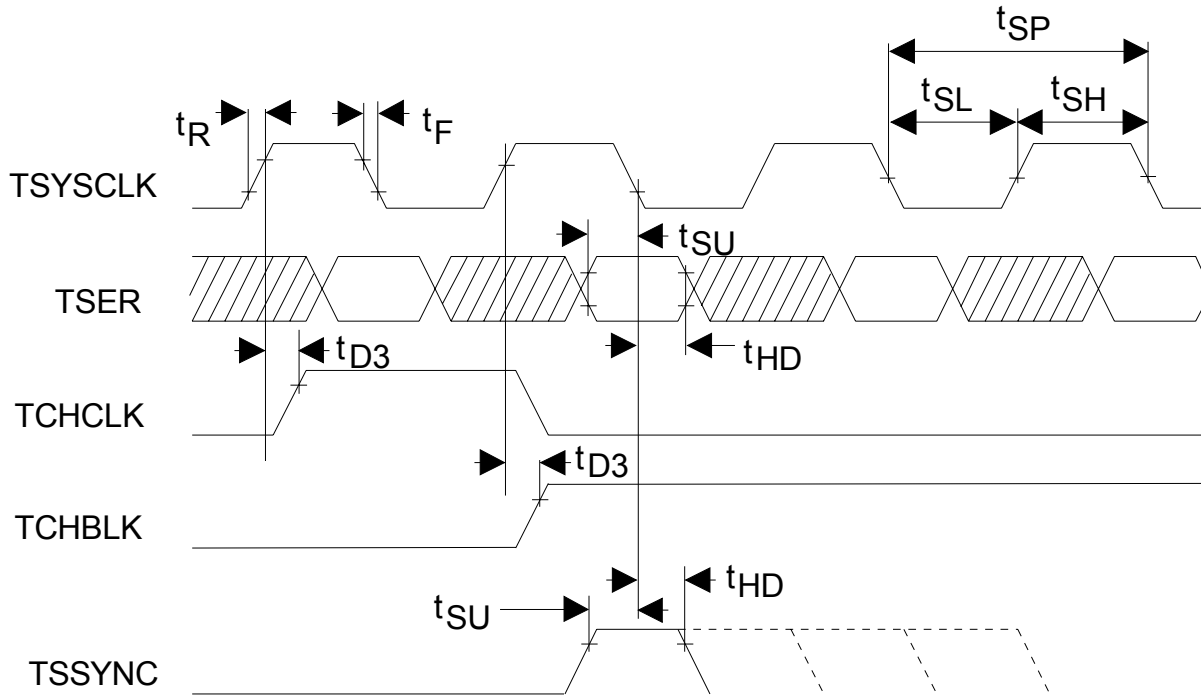
**Figure 24-12 TRANSMIT SIDE TIMING, ELASTIC STORE ENABLED**

## Notes:

1. TSER is only sampled on the falling edge of TSYSCLK when the transmit side elastic store is enabled.
2. TCHCLK and TCHBLK are synchronous with TSYSCLK when the transmit side elastic store is enabled.

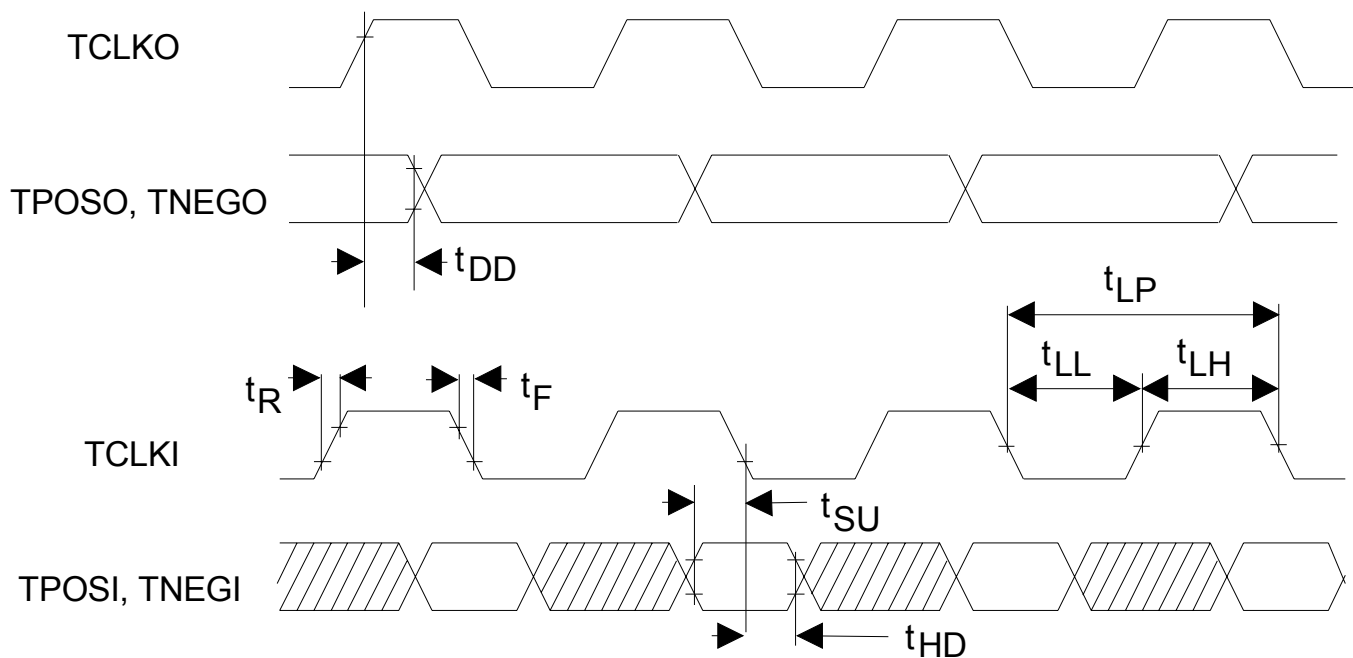
**Figure 24-13 TRANSMIT LINE INTERFACE TIMING**



## 25. MECHANICAL DESCRIPTION

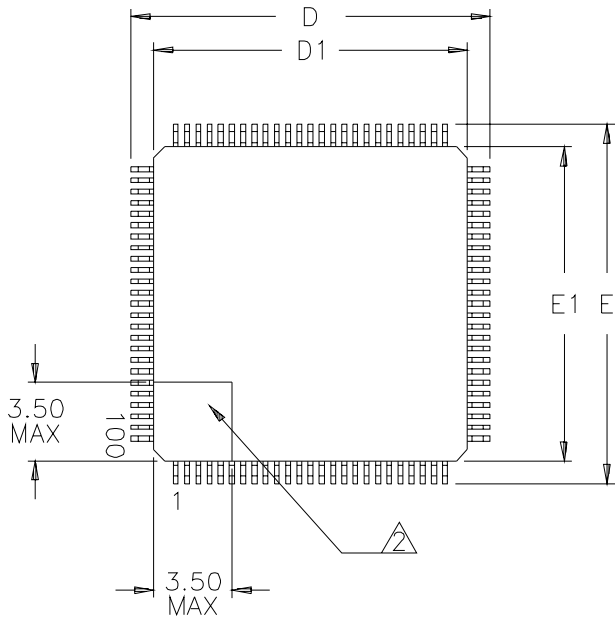

NOTES:

1. DIMENSIONS D1 AND E1 INCLUDE MOLD MISMATCH, BUT DO NOT INCLUDE MOLD PROTRUSION; ALLOWABLE PROTRUSION IS 0.25 MM PER SIDE.
- △ DETAILS OF PIN 1 IDENTIFIER ARE OPTIONAL BUT MUST BE LOCATED WITHIN THE ZONE INDICATED.
3. ALLOWABLE DAMBAR PROTRUSION IS 0.08 MM TOTAL IN EXCESS OF THE b DIMENSION; PROTRUSION NOT TO BE LOCATED ON LOWER RADIUS OR FOOT OF LEAD.
4. ALL DIMENSIONS ARE IN MILLIMETERS.

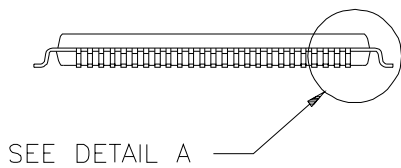

DIM	MIN	MAX
A	-	1.60
A1	0.05	-
A2	1.35	1.45
b	0.17	0.27
c	0.09	0.20
D	15.80	16.20
D1	14.00	BSC
E	15.80	16.20
E1	14.00	BSC
e	0.50	BSC
L	0.45	0.75

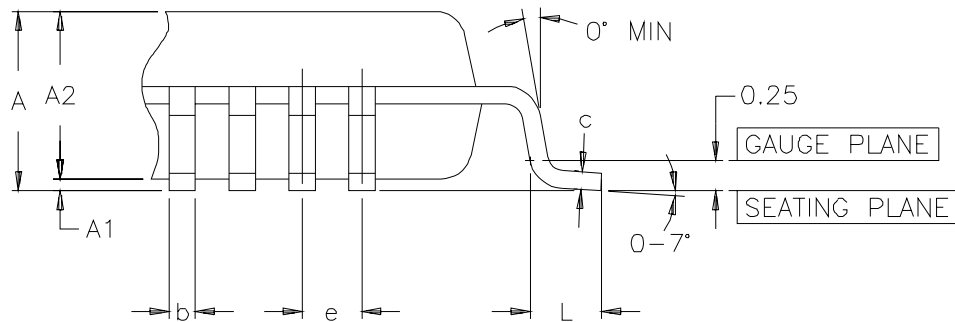

DETAIL A