

RM7065A

RM7065A™ Microprocessor with On- Chip Secondary Cache

Data Sheet

Preliminary

Issue 2, June 2001

Legal Information

Copyright

© 2001 PMC-Sierra, Inc.

The information is proprietary and confidential to PMC-Sierra, Inc., and for its customers' internal use. In any event, you cannot reproduce any part of this document, in any form, without the express written consent of PMC-Sierra, Inc.

PMC-2010145 (P1)

Disclaimer

None of the information contained in this document constitutes an express or implied warranty by PMC-Sierra, Inc. as to the sufficiency, fitness or suitability for a particular purpose of any such information or the fitness, or suitability for a particular purpose, merchantability, performance, compatibility with other parts or systems, of any of the products of PMC-Sierra, Inc., or any portion thereof, referred to in this document. PMC-Sierra, Inc. expressly disclaims all representations and warranties of any kind regarding the contents or use of the information, including, but not limited to, express and implied warranties of accuracy, completeness, merchantability, fitness for a particular use, or non-infringement.

In no event will PMC-Sierra, Inc. be liable for any direct, indirect, special, incidental or consequential damages, including, but not limited to, lost profits, lost business or lost data resulting from any use of or reliance upon the information, whether or not PMC-Sierra, Inc. has been advised of the possibility of such damage.

Trademarks

RM7000A and Fast Packet Cache are trademarks of PMC-Sierra, Inc.

Patents

The technology discussed is protected by one or more of the following Patents:

U.S. Patent Numbers 5,953,748 5,606,683 5,760,620.

Relevant patent applications and other patents may also exist.

Contacting PMC-Sierra

PMC-Sierra, Inc.
105-8555 Baxter Place Burnaby, BC
Canada V5A 4V7

Tel: (604) 415-6000
Fax: (604) 415-6200

Document Information: document@pmc-sierra.com
Corporate Information: info@pmc-sierra.com
Technical Support: apps@pmc-sierra.com
Web Site: <http://www.pmc-sierra.com>

Revision History

Issue No.	Issue Date	Details of Change
2	June 2001	Changed IP references to INT, page 34. Changed W7 pin name to SysClk.
1	April 2001	Applied PMC-Sierra template to existing MPD (QED) preliminary FrameMaker document. Updated Sections 4.33, 4.34, 4.38, 9, and 12. In the Pinout Table, changed all references from IP to Int. Changed QED references to PMC-Sierra or MIPS.

Document Conventions

The following conventions are used in this datasheet:

- All signal, pin, and bus names described in the text, such as **ExtRqst***, are in boldface typeface.
- All bit and field names described in the text, such as *Interrupt Mask*, are in an italic-bold typeface.
- All instruction names, such as MFHI, are in san serif typeface.

Table of Contents

1	Features	9
2	Block Diagram	10
3	Description	11
4	Hardware Overview	12
4.1	CPU Registers	12
4.2	Superscalar Dispatch	12
4.3	Pipeline	13
4.4	Integer Unit	14
4.5	ALU	15
4.6	Integer Multiply/Divide	15
4.7	Floating-Point Coprocessor	16
4.8	Floating-Point Unit	16
4.9	Floating-Point General Register File	17
4.10	System Control Coprocessor (CP0)	18
4.11	System Control Coprocessor Registers	18
4.12	Virtual to Physical Address Mapping	19
4.13	Joint TLB	20
4.14	Instruction TLB	21
4.15	Data TLB	21
4.16	Cache Memory	22
4.17	Instruction Cache	22
4.18	Data Cache	22
4.19	Secondary Cache	24
4.20	Secondary Caching Protocols	24
4.21	Cache Locking	25
4.22	Cache Management	26
4.23	Primary Write Buffer	26
4.24	System Interface	26
4.25	System Address/Data Bus	27
4.26	System Command Bus	27
4.27	Handshake Signals	28
4.28	System Interface Operation	28
4.29	Data Prefetch	30
4.30	Enhanced Write Modes	31
4.31	External Requests	31
4.32	Test/Breakpoint Registers	31
4.33	Performance Counters	32
4.34	Interrupt Handling	34
4.35	Standby Mode	36

4.36	JTAG Interface	36
4.37	Boot-Time Options	36
4.38	Boot-Time Modes	36
5	Pin Descriptions	38
6	Absolute Maximum Ratings	41
7	Recommended Operating Conditions	42
8	DC Electrical Characteristics	43
9	Power Consumption	44
10	AC Electrical Characteristics	45
10.1	Capacitive Load Deration	45
10.2	Clock Parameters	45
10.3	System Interface Parameters	46
10.4	Boot-Time Interface Parameters	46
11	Timing Diagrams	47
11.1	Clock Timing	47
12	Packaging Information	48
13	RM7065A Pinout	50
14	Ordering Information	52

List of Figures

Figure 1	Block Diagram	10
Figure 2	CP0 Registers	12
Figure 3	Instruction Issue Paradigm	13
Figure 4	Pipeline	14
Figure 5	CP0 Registers	19
Figure 6	Kernel Mode Virtual Addressing (32-bit)	20
Figure 7	Typical Embedded System Block Diagram	27
Figure 8	Processor Block Read	29
Figure 9	Processor Block Write	30
Figure 10	Multiple Outstanding Reads	30
Figure 11	Clock Timing	47
Figure 12	Input Timing	47
Figure 13	Output Timing	47
Figure 14	Mechanical Diagram	48

List of Tables

Table 1	Instruction Issue Rules	12
Table 2	Dual Issue Instruction Classes	13
Table 3	ALU Operations	15
Table 4	Integer Multiply/Divide Operations	15
Table 5	Floating Point Latencies and Repeat Rates	17
Table 6	Cache Attributes	25
Table 7	Cache Locking Control	26
Table 8	Penalty Cycles	26
Table 9	Watch Control Register	32
Table 10	Performance Counter Control	33
Table 11	Cause Register	35
Table 12	Interrupt Control Register	35
Table 13	IPLLO Register	35
Table 14	IPLHI Register	35
Table 15	Interrupt Vector Spacing	36
Table 16	Boot Time Mode Stream	37
Table 17	System Interface	38
Table 18	Clock/Control Interface	39
Table 19	Interrupt Interface	40
Table 20	JTAG Interface	40
Table 21	Initialization Interface	40

1 Features

- Dual issue symmetric superscalar microprocessor with instruction prefetch optimized for system level price/performance
 - 300, 350 MHz operating frequency
 - >525 Dhrystone 2.1 MIPS @ 350 MHz
- High-performance system interface
 - 1000 MB per second peak throughput
 - 125 MHz max. freq., multiplexed address/data
 - Supports two outstanding reads with out-of-order return
 - Processor clock multipliers 2, 2.5, 3, 3.5, 4, 4.5, 5, 6, 7, 8, 9
- Integrated primary and secondary caches
 - All are 4-way set associative with 32 byte line size
 - 16 KB instruction, 16 KB data, 256 KB on-chip secondary
 - Per line cache locking in primaries and secondary
 - Fast Packet Cache™ increases system efficiency in networking applications
- High-performance floating-point unit — 800 MFLOPS maximum
 - Single cycle repeat rate for common single-precision operations and some double-precision operations
 - Single cycle repeat rate for single-precision combined multiply-add operations
 - Two cycle repeat rate for double-precision multiply and double-precision combined multiply-add operations
- MIPS IV superset instruction set architecture
 - Data PREFETCH instruction allows the processor to overlap cache miss latency and instruction execution
 - Single-cycle floating-point multiply-add
- Integrated memory management unit
 - Fully associative joint TLB (shared by I and D translations)
 - 64/48 dual entries map 128/96 pages
 - Variable page size
- Embedded application enhancements
 - Specialized DSP integer Multiply-Accumulate instructions, (MAD/MADU) and three-operand multiply instruction (MUL)
 - I&D Test/Break-point (Watch) registers for emulation & debug
 - Performance counter for system and software tuning & debug
 - Fourteen fully prioritized vectored interrupts — 10 external, 2 internal, 2 software
- Fully static CMOS design with dynamic power down logic

2 Block Diagram

Figure 1 Block Diagram

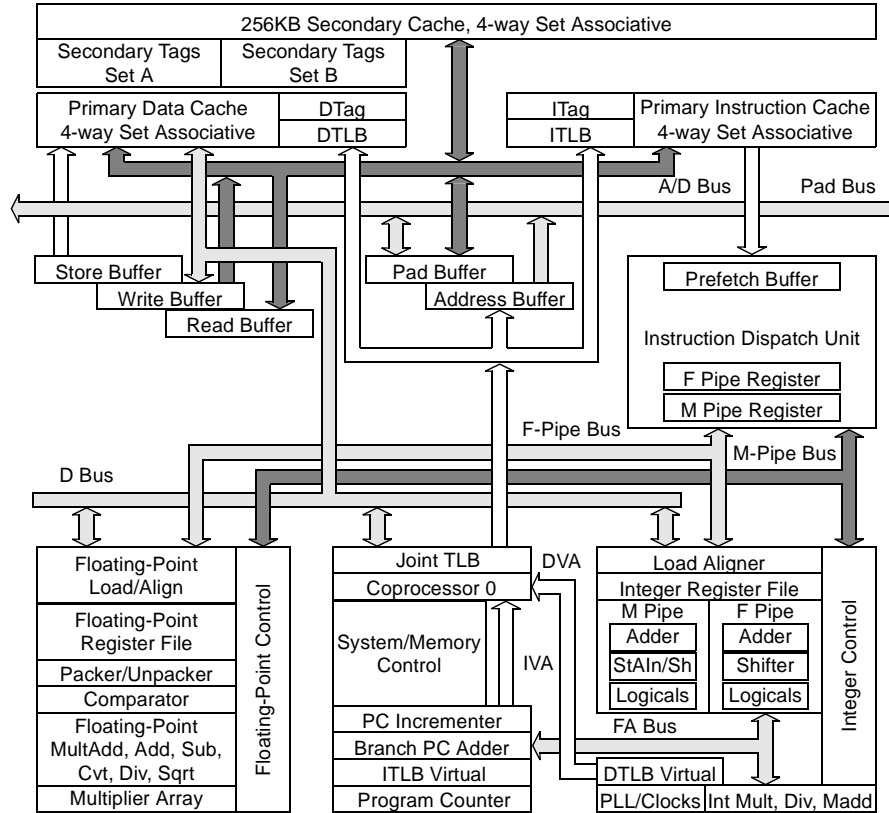

3 Description

PMC-Sierra's RM7065A is a highly integrated symmetric superscalar microprocessor capable of issuing two instructions each processor cycle. It has two high-performance 64-bit integer units as well as a high-throughput, fully pipelined 64-bit floating point unit.

The RM7065A integrates 16 KB 4-way set associative instruction and data caches along with an integrated 256 KB 4-way set associative secondary. The primary data and secondary caches are write-back and non-blocking.

The memory management unit contains a 64/48-entry fully associative TLB and a 64-bit system interface supporting multiple outstanding reads with out-of-order return and hardware prioritized and vectored interrupts.

The RM7065A ideally suits high-end embedded control applications such as internetworking, high-performance image manipulation, high-speed printing, and 3-D visualization. The RM7065A is also applicable to the low end workstation market where its balanced integer and floating-point performance provide outstanding price/performance.

4 Hardware Overview

The RM7065A offers a high-level of integration targeted at high-performance embedded applications. The key elements of the RM7065A are described throughout this section.

4.1 CPU Registers

The RM7065A CPU contains 32 general purpose registers (GPR), two special purpose registers for integer multiplication and division, and a program counter; there are no condition code bits. Figure 2 shows the user visible state.

Figure 2 CP0 Registers

General Purpose Registers

63	0
0	
r1	
r2	
•	
•	
•	
•	
r29	
r30	
r31	

Multiply/Divide Registers

63	0
HI	
63	0
LO	

Program Counter

63	0
PC	

4.2 Superscalar Dispatch

The RM7065A incorporates a superscalar dispatch unit that allows it to issue up to two instructions per cycle. For purposes of instruction issue, the RM7065A defines four classes of instructions: integer, load/store, branches, and floating-point. There are two logical pipelines, the *function*, or F, pipeline and the *memory*, or M, pipeline. Note however that the M pipe can execute integer as well as memory type instructions.

Table 1 Instruction Issue Rules

F Pipe	M Pipe
one of:	one of:
integer, branch, floating-point, integer mul, div	integer, load/store

Figure 2 is a simplification of the pipeline section and illustrates the basics of the instruction issue mechanism.

Figure 3 Instruction Issue Paradigm

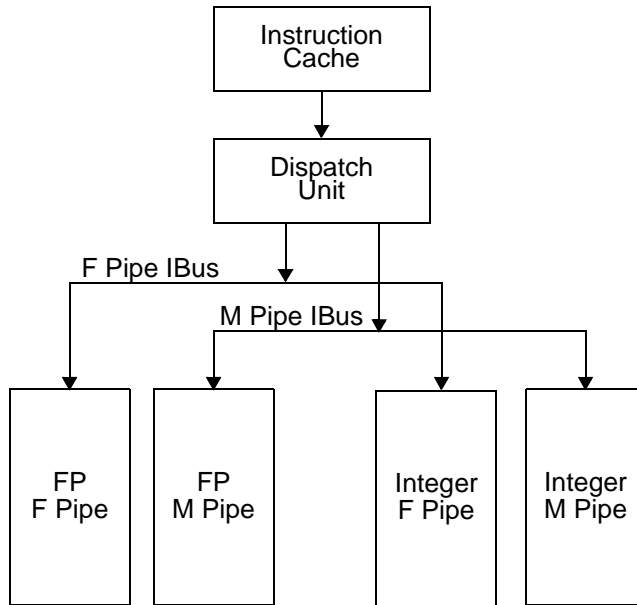

The figure illustrates that one F pipe instruction and one M pipe instruction can be issued concurrently but that two M pipe or two F pipe instructions cannot be issued. Table 2 specifies more completely the instructions within each class.

Table 2 Dual Issue Instruction Classes

integer	load/store	floating-point	branch
add, sub, or, xor, shift, etc.	lw, sw, ld, sd, ldc1, sdc1, mov, movc, fmov, etc.	fadd, fsub, fmult, fmadd, fdiv, fcmp, fsqrt, etc.	beq, bne, bCzT, bCzF, j, etc.

4.3 Pipeline

The logical length of both the F and M pipelines is five stages with state committing in the register write, or W, pipe stage. The physical length of the floating-point execution pipeline is actually seven stages but this is completely transparent to the user.

Figure 4 shows instruction execution within the RM7065A when instructions are issuing simultaneously down both pipelines. As illustrated in the figure, up to ten instructions can be executing simultaneously. This figure presents a somewhat simplistic view of the processors operation since the out-of-order completion of loads, stores, and long latency floating-point operations can result in there being even more instructions in process than what is shown.

Figure 4 Pipeline

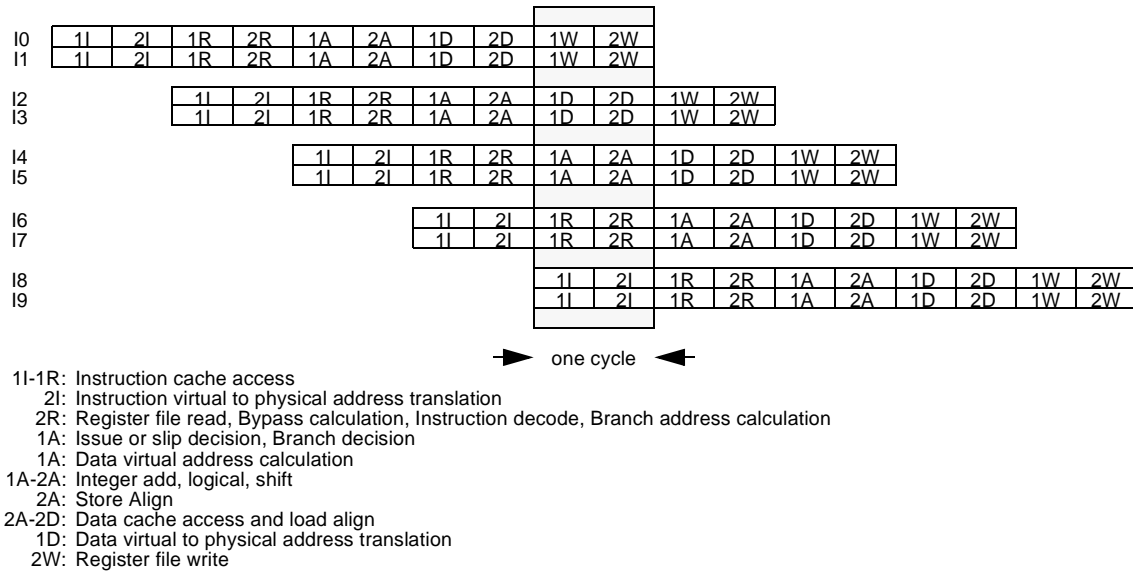

Note that instruction dependencies, resource conflicts, and branches may result in some of the instruction slots being occupied by NOPs.

4.4 Integer Unit

The RM7065A implements the MIPS IV Instruction Set Architecture. Additionally, the RM7065A includes two implementation specific instructions not found in the baseline MIPS IV ISA, but that are useful in the embedded market place. These instructions are integer multiply-accumulate (MAD) and three-operand integer multiply (MUL).

The RM7065A integer unit includes thirty-two general purpose 64-bit registers, the HI/LO result registers for two-operand integer multiply/divide operations, and the program counter, or PC. There are two separate execution units, one of which can execute function (F) type instructions and one which can execute memory (M) type instructions. Refer to Table 1 for the instruction issue rules.

Note that integer multiply/divide instructions, as well as their corresponding MFHI and MFLO instructions, can only be executed in the F type execution unit. Within each execution unit the operational characteristics are the same as on previous MIPS designs with single cycle ALU operations (add, sub, logical, shift), one cycle load delay, and an autonomous multiply/divide unit.

Register File

The RM7065A has thirty-two general purpose registers with register location 0 (r0) hard wired to a zero value. These registers are used for scalar integer operations and address calculation. In order to service the two integer execution units, the register file has four read ports and two write ports and is fully bypassed both within and between the two execution units to minimize operation latency in the pipeline.

4.5 ALU

The RM7065A has two complete integer ALUs each consisting of an integer adder/subtractor, a logic unit, and a shifter. Table 3 shows the functions performed by the ALUs for each execution unit. Each of these units is optimized to perform all operations in a single processor cycle.

Table 3 ALU Operations

Unit	F Pipe	M Pipe
Adder	add, sub	add, sub, data address add
Logic	logic, moves, zero shifts (nop)	logic, moves, zero shifts (nop)
Shifter	non zero shift	non zero shift, store align

4.6 Integer Multiply/Divide

The RM7065A has a single dedicated integer multiply/divide unit optimized for high-speed multiply and multiply-accumulate operations. The multiply/divide unit resides in the F type execution unit. Table 4 shows the performance of the multiply/divide unit on each operation.

Table 4 Integer Multiply/Divide Operations

Opcode	Operand Size	Latency	Repeat Rate	Stall Cycles
MULT/U, MAD/U	16 bit	4	3	0
	32 bit	5	4	0
MUL	16 bit	4	3	2
	32 bit	5	4	3
DMULT, DMULTU	any	9	8	0
DIV, DIVD	any	36	36	0
DDIV, DDIVU	any	68	68	0

The baseline MIPS IV ISA specifies that the results of a multiply or divide operation be placed in the Hi and Lo registers. These values can then be transferred to the general purpose register file using the Move-from-Hi and Move-from-Lo (MFHI/MFLO) instructions.

In addition to the baseline MIPS IV integer multiply instructions, the RM7065A also implements the 3-operand multiply instruction, MUL. This instruction specifies that the multiply result go directly to the integer register file rather than the Lo register. The portion of the multiply that would have normally gone into the Hi register is discarded. For applications where it is known that the upper half of the multiply result is not required, using the MUL instruction eliminates the necessity of executing an explicit MFLO instruction.

The multiply-add instructions, MAD and MADU, multiply two operands and add the resulting product to the current contents of the Hi and Lo registers. The multiply-accumulate operation is

the core primitive of almost all signal processing algorithms. Therefore, using the RM7065A eliminates the need for a separate DSP engine in many embedded applications.

4.7 Floating-Point Coprocessor

The RM7065A incorporates a high-performance fully pipelined floating-point coprocessor which includes a floating-point register file and autonomous execution units for multiply/add/convert and divide/square root. The floating-point coprocessor is a tightly coupled execution unit, decoding and executing instructions in parallel with, and in the case of floating-point loads and stores, in cooperation with the M pipe of the integer unit. The superscalar capabilities of the RM7065A allow floating-point computation instructions to issue concurrently with integer instructions.

4.8 Floating-Point Unit

The RM7065A floating-point execution unit supports single and double precision arithmetic, as specified in the IEEE Standard 754. The execution unit is broken into a separate divide/square root unit and a pipelined multiply/add unit. Overlap of divide/square root and multiply/add is supported.

The RM7065A maintains fully precise floating-point exceptions while allowing both overlapped and pipelined operations. Precise exceptions are extremely important in object-oriented programming environments and highly desirable for debugging in any environment.

Floating-point operations include:

- add
- subtract
- multiply
- divide
- square root
- reciprocal
- reciprocal square root
- conditional moves
- conversion between fixed-point and floating-point format
- conversion between floating-point formats
- floating-point compare

Table 5 gives the latencies of the floating-point instructions in internal processor cycles.

Table 5 Floating Point Latencies and Repeat Rates

Operation	Latency single/double	Repeat Rate single/double
fadd	4	1
fsub	4	1
fmult	4/5	1/2
fmadd	4/5	1/2
fmsub	4/5	1/2
fdiv	21/36	19/34
fsqrt	21/36	19/34
frecip	21/36	19/34
frsqrt	38/68	36/66
fcvt.s.d	4	1
fcvt.s.w	6	3
fcvt.s.l	6	3
fcvt.d.s	4	1
fcvt.d.w	4	1
fcvt.d.l	4	1
fcvt.w.s	4	1
fcvt.w.d	4	1
fcvt.l.s	4	1
fcvt.l.d	4	1
fcmp	1	1
fmov, fmovc	1	1
fabs, fneg	1	1

4.9 Floating-Point General Register File

The floating-point general register file (FGR) is made up of thirty-two 64-bit registers. With the floating-point load and store double instructions, LDC1 and SDC1, the floating-point unit can take advantage of the 64-bit wide data cache and issue a floating-point coprocessor load or store doubleword instruction in every cycle.

The floating-point control register file contains two registers; one for determining configuration and revision information for the coprocessor, and one for control and status information. These registers are primarily used for diagnostic software, exception handling, state saving and restoring, and control of rounding modes.

To support superscalar operations the FGR has four read ports and two write ports and is fully bypassed to minimize operation latency in the pipeline. Three of the read ports and one write port are used to support the combined multiply-add instruction while the fourth read and second write port allows for concurrent floating-point load or store and conditional move operations.

4.10 System Control Coprocessor (CP0)

The system control coprocessor (CP0) is responsible for the virtual memory sub-system, the exception control system, and the diagnostics capability of the processor.

For memory management support, the RM7065A CP0 is logically identical to the RM5200 Family. For interrupt exceptions and diagnostics, the RM7065A is a superset of the RM5200 Family, implementing additional features described in the following sections on Interrupts, Test/Breakpoint registers, and Performance Counters.

The memory management unit controls the virtual memory system page mapping. It consists of an instruction address translation buffer (ITLB) a data address translation buffer (DTLB), a Joint TLB (JTLB), and coprocessor registers used by the virtual memory mapping sub-system.

4.11 System Control Coprocessor Registers

The RM7065A incorporates all CP0 registers internally. These registers provide the path through which the virtual memory system's page mapping is examined and modified, exceptions are handled, and operating modes are controlled (kernel vs. user mode, interrupts enabled or disabled, cache features). In addition, the RM7065A includes registers to implement a real-time cycle counting facility, to aid in cache and system diagnostics, and to assist in data error detection.

To support the non-blocking caches and enhanced interrupt handling capabilities of the RM7065A, both the data and control register spaces of CP0 are supported. In the data register space, which is accessed using the MFC0 and MTC0 instructions, the RM7065A supports the same registers as found in the RM5200 Family. In the control space, which is accessed by the previously unused CTC0 and CFC0 instructions, the RM7065A supports five new registers. The first three of these new 32-bit registers support the enhanced interrupt handling capabilities; Interrupt Control, Interrupt Priority Level Lo (IPLLO), and Interrupt Priority Level Hi (IPLHI). These registers are described further in the section on interrupt handling. Two other registers, Imprecise Error 1 and Imprecise Error 2, have been added to help diagnose bus errors that occur on non-blocking memory references.

Figure 5 shows the CP0 registers.

Figure 5 CP0 Registers

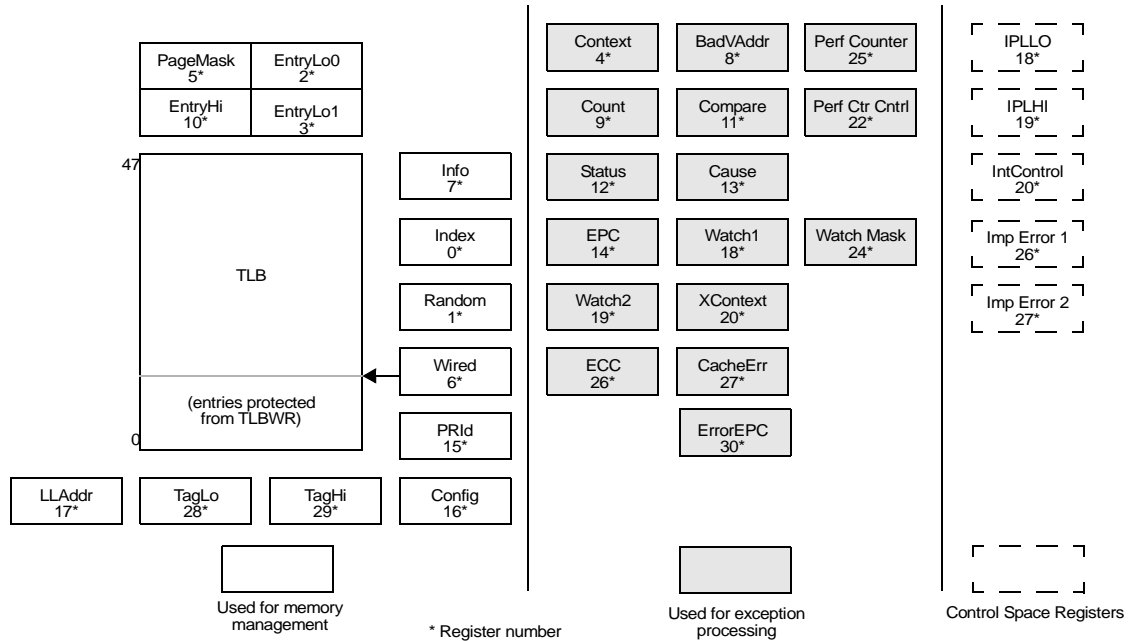

4.12 Virtual to Physical Address Mapping

The RM7065A provides three modes of virtual addressing:

- user mode
- kernel mode
- supervisor mode

These modes allow system software to provide a secure environment for user processes. Bits in the CP0 Status register determine which virtual addressing mode is used. In user mode, the RM7065A provides a single, uniform virtual address space of 256 GB (2 GB in 32-bit mode).

When operating in the kernel mode, four distinct virtual address spaces, totalling 1024 GB (4 GB in 32-bit mode), are simultaneously available and are differentiated by the high-order bits of the virtual address.

The RM7065A processor also supports a supervisor mode in which the virtual address space is 256.5 GB (2.5 GB in 32-bit mode), divided into three regions based on the high-order bits of the virtual address. Figure 6 shows the address space layout for 32-bit operations.

Figure 6 Kernel Mode Virtual Addressing (32-bit)

0xFFFFFFFF	Kernel virtual address space (kseg3)
0xE0000000	
0xDFFFFFFF	Supervisor virtual address space (ksseg)
0xC0000000	
0xBFFFFFFF	Uncached kernel physical address space (kseg1)
0xA0000000	
0x9FFFFFFF	Cached kernel physical address space (kseg0)
0x80000000	
0x7FFFFFFF	User virtual address space (kuseg) Mapped, 2.0GB
0x00000000	

When the RM7065A is configured for 64-bit addressing, the virtual address space layout is an upward compatible extension of the 32-bit virtual address space layout.

4.13 Joint TLB

For fast virtual-to-physical address translation, the RM7065A uses a large, fully associative TLB that maps virtual pages to their corresponding physical addresses. As indicated by its name, the JTLB is used for both instruction and data translations. The JTLB is organized as pairs of even/odd entries, and maps a virtual address and address space identifier (ASID) into the large, 64 GB physical address space. By default, the JTLB is configured as 48 pairs of even/odd entries. The optional 64 even/odd entry configuration is set at boot time.

Two mechanisms are provided to assist in controlling the amount of mapped space and the replacement characteristics of various memory regions. First, the page size can be configured, on a per-entry basis, to use page sizes in the range of 4 KB to 16 MB (in 4x multiples). The CP0 PageMask register is loaded with the desired page size of a mapping, and that size is stored into the TLB, along with the virtual address, when a new entry is written. Thus, operating systems can

create special purpose maps; for example, an entire frame buffer can be memory mapped using only one TLB entry.

The second mechanism controls the replacement algorithm when a TLB miss occurs. The RM7065A provides a random replacement algorithm to select a TLB entry to be written with a new mapping. However, the processor also provides a mechanism whereby a system specific number of mappings can be locked into the TLB, thereby avoiding random replacement. This mechanism uses the CPO Wired register and allows the operating system to guarantee that certain pages are always mapped for performance reasons and to avoid a deadlock condition. This mechanism also facilitates the design of real-time systems by allowing deterministic access to critical software.

The JTLB also contains information that controls the cache coherency protocol for each page. Specifically, each page has attribute bits to determine whether the coherency algorithm is:

- uncached
- write-back
- write-through with write-allocate
- write-through without write-allocate
- write-back with secondary bypass

Note that both of the write-through protocols bypass the secondary cache since it does not support writes of less than a complete cache line.

These protocols are used for both code and data on the RM7065A with data using write-back or write-through depending on the application. The write-through modes support the same efficient frame buffer handling as the RM5200 Family.

4.14 Instruction TLB

The RM7065A uses a 4-entry instruction TLB (ITLB). The ITLB offers the following advantages;

- Minimizes contention for the JTLB
- Eliminates the critical path of translating through a large associative array
- Allows instruction address and data address translations to occur in parallel
- Saves power

Each ITLB entry maps a 4 KB page. The ITLB improves performance by allowing instruction address translation to occur in parallel with data address translation. When a miss occurs on an instruction address translation by the ITLB, the least-recently used ITLB entry is filled from the JTLB. The operation of the ITLB is completely transparent to the user.

4.15 Data TLB

The RM7065A uses a 4-entry data TLB (DTLB) for the same reasons cited above for the ITLB. Each DTLB entry maps a 4 KB page. The DTLB improves performance by allowing data address translation to occur in parallel with instruction address translation. When a miss occurs on a data address translation, the DTLB is filled from the JTLB. The DTLB refill is pseudo-LRU; the least recently used entry of the least recently used pair of entries is filled. The operation of the DTLB is completely transparent to the user.

4.16 Cache Memory

The RM7065A contains integrated primary instruction and data caches that support single cycle access, as well as a large unified secondary cache with a three cycle miss penalty from the primary caches. Each primary cache has a 64-bit read path and a 128-bit write path. Both caches can be accessed simultaneously. The primary caches provide the integer and floating-point units with an aggregate bandwidth of 5.6 GB per second at an internal clock frequency of 350 MHz. During an instruction or data primary cache refill, the secondary cache can provide a 64-bit datum every cycle following the initial three cycle latency for a peak bandwidth of 2.8 GB per second.

4.17 Instruction Cache

The RM7065A has an integrated 16 KB, four-way set associative instruction cache that is virtually indexed and physically tagged. The effective physical index eliminates the potential for virtual aliases in the cache.

The data array portion of the instruction cache is 64 bits wide and protected by word parity while the tag array holds a 24-bit physical address, 14 control bits, a valid bit, and a single parity bit.

By accessing 64 bits per cycle, the instruction cache is able to supply two instructions per cycle to the superscalar dispatch unit. For signal processing, graphics, and other numerical code sequences where a floating-point load or store and a floating-point computation instruction are being issued together in a loop, the entire bandwidth available from the instruction cache is consumed by instruction issue. For typical integer code mixes, where instruction dependencies and other resource constraints restrict the level of parallelism that can be achieved, the extra instruction cache bandwidth is used to fetch both the taken and non-taken branch paths to minimize the overall penalty for branches.

A 32-byte (eight instruction) line size is used to maximize the communication efficiency between the instruction cache and the secondary cache or memory system.

The RM7065A supports cache locking on a per line basis. The contents of each line of the cache can be *locked* by setting a bit in the Tag RAM. Locking the line prevents its contents from being overwritten by a subsequent cache miss. Refills occur only into unlocked cache lines. This mechanism allows the programmer to lock critical code into the cache, thereby guaranteeing deterministic behavior for the locked code sequence.

4.18 Data Cache

The RM7065A has an integrated 16 KB, four-way set associative data cache that is virtually indexed and physically tagged. Line size is 32 bytes (8 words). The effective physical index eliminates the potential for virtual aliases in the cache.

The data cache is non-blocking; that is, a miss in the data cache does not necessarily stall the processor pipeline. As long as no instruction is encountered which is dependent on the data reference which caused the miss, the pipeline continues to advance. Once there are two cache misses outstanding, the processor stalls if it encounters another load or store instruction.

The data array portion of the data cache is 64 bits wide and protected by byte parity while the tag array holds a 24-bit physical address, 3 control bits, a two-bit cache state field, and two parity bits.

The most commonly used write policy is write-back, which means that a store to a cache line does not immediately cause memory to be updated. This increases system performance by reducing bus traffic and eliminating the bottleneck of waiting for each store operation to finish before issuing a subsequent memory operation. Software can, however, select write-through on a per-page basis when appropriate, such as for frame buffers. Cache protocols supported for the data cache are as follows:

1. Uncached

Reads to addresses in a memory area identified as uncached do not access the cache. Writes to such addresses are written directly to main memory without updating the cache.

2. Write-back

Loads and instruction fetches first search the cache, reading the next memory hierarchy level only if the desired data is not cache resident. On data store operations, the cache is first searched to determine if the target address is cache resident. If it is resident, the cache contents are updated and the cache line is marked for later write-back. If the cache lookup misses, the target line is first brought into the cache, after which the write is performed as above.

3. Write-through with write allocate

Loads and instruction fetches first search the cache, reading from memory only if the desired data is not cache resident; write-through data is never cached in the secondary cache. On data store operations, the cache is first searched to determine if the target address is cache resident. If it is resident, the primary cache contents are updated and main memory is written, leaving the *write-back* bit of the cache line unchanged; no writes occur to the secondary cache. If the cache lookup misses, the target line is first brought into the cache, after which the write is performed as above.

4. Write-through without write allocate

Loads and instruction fetches first search the cache, reading from memory only if the desired data is not cache resident; write-through data is never cached in the secondary cache. On data store operations, the cache is first searched to determine if the target address is cache resident. If it is resident, the cache contents are updated and main memory is written, leaving the *write-back* bit of the cache line unchanged; no writes occur to the secondary cache. If the cache lookup misses, only main memory is written.

5. Fast Packet Cache™ (Write-back with secondary bypass)

Loads and instruction fetches first search the primary cache, reading from memory only if the desired data is not resident; the secondary cache is not searched. On data store operations, the primary cache is first searched to determine if the target address is resident. If it is resident, the cache contents are updated, and the cache line marked for later write-back. If the cache lookup misses, the target line is first brought into the cache, after which the write is performed as above.

Associated with the data cache is the *store buffer*. When the RM7065A executes a **STORE** instruction, this single-entry buffer is written with the store data while the tag comparison is performed. If the tag matches, then the data is written into the data cache in the next cycle that the data cache is not accessed (the next non-load cycle). The store buffer allows the RM7065A to

execute a store every processor cycle and to perform back-to-back stores without penalty. In the event of a store immediately followed by a load to the same address, a combined merge and cache write occurs such that no penalty is incurred.

4.19 Secondary Cache

The RM7065A has an integrated 256 KB, four-way set associative, block write-back secondary cache. The secondary cache has a 32-byte line size, a 64-bit bus width to match the system interface and primary cache bus widths, and is protected with doubleword parity. The secondary cache tag array holds a 20-bit physical address, 2 control bits, a three bit cache state field, and two parity bits.

By integrating a secondary cache, the RM7065A is able to decrease the latency of a primary cache miss without significantly increasing the number of pins and the amount of power required by the processor. From a technology point of view, integrating a secondary cache leverages CMOS technology by using silicon to build the structures that are most amenable to silicon technology; building very dense, low power memory arrays rather than large power hungry I/O buffers.

Further benefits of an integrated secondary cache are flexibility in the cache organization and management policies that are not practical with an external cache. Two previously mentioned examples are the 4-way associativity and write-back cache protocol.

A third management policy for which integration affords flexibility is cache hierarchy management. With multiple levels of cache, it is necessary to specify a policy for dealing with cases where two cache lines at level n of the hierarchy could possibly be sharing an entry in level $n+1$ of the hierarchy.

The RM7065A allows entries to be stored in the primary caches that do not necessarily have a corresponding entry in the secondary; the RM7065A does not force the primaries to be a subset of the secondary. For example, if primary cache line A is being filled and a cache line already exists in the secondary for primary cache line B at the location where primary A's line would reside, then that secondary entry is replaced by an entry corresponding to primary cache line A and no action occurs in the primary for cache line B. This operation creates the aforementioned scenario where the primary cache line, which initially had a corresponding secondary entry, no longer has such an entry. Such a primary line is called an *orphan*. In general, cache lines at level $n+1$ of the hierarchy are called *parents* of level n 's *children*.

Another RM7065A cache management optimization occurs for the case of a secondary cache line replacement where the secondary line is dirty and has a corresponding dirty line in the primary. In this case, since it is permissible to leave the dirty line in the primary, it is not necessary to write the secondary line back to main memory. Taking this scenario one step further, a final optimization occurs when the aforementioned dirty primary line is replaced by another line and must be written back. In this case it is written directly to memory, bypassing the secondary cache.

4.20 Secondary Caching Protocols

Unlike the primary data cache, the secondary cache supports only uncached and block write-back. As noted earlier, cache lines managed with either of the write-through protocols are not placed in the secondary cache. A new caching attribute, *write-back with secondary bypass*, allows the secondary cache to be bypassed entirely. When this attribute is selected, the secondary cache is not filled on load misses and are not written on dirty write-backs from the primary cache

The RM7065A cache attributes for the instruction, data, internal secondary caches are summarized in Table 6.

Table 6 Cache Attributes

Attribute	Instruction	Data	Secondary
Size	16KB	16KB	256KB
Associativity	4-way	4-way	4-way
Replacement Algorithm	cyclic	cyclic	cyclic
Line size	32 byte	32 byte	32 byte
Index	vAddr _{11..0}	vAddr _{11..0}	pAddr _{15..0}
Tag	pAddr _{35..12}	pAddr _{35..12}	pAddr _{35..16}
Write policy	n.a.	write-back, write-through	block write-back, bypass
read policy	n.a.	non-blocking (2 outstanding)	non-blocking (data only, 2 outstanding)
read order	critical word first	critical word first	critical word first
write order	NA	sequential	sequential
miss restart following:	complete line	first double (if waiting for data)	n.a.
Parity	per word	per byte	per doubleword

4.21 Cache Locking

The RM7065A allows critical code or data fragments to be locked into the primary and secondary caches. The user has complete control over the locking function. For instruction and data fragments in the primary caches, locking is accomplished by setting either or both of the cache lock enable bits and specifying the set in the CP0 ECC register, then executing either a load instruction for data, or a Fill_I cache operation for instructions.

Only sets A and B within each cache can be locked. Locking within the secondary works identically to the primaries using a separate secondary lock enable bit and the same set selection field. As with the primaries, only sets A and B can be locked. Table 7 summarizes the cache locking capabilities.

Table 7 Cache Locking Control

Cache	Lock Enable	Set Select	Activate
Primary I	ECC[27]	ECC[28]=0→A ECC[28]=1→B	Fill_I
Primary D	ECC[26]	ECC[28]=0→A ECC[28]=1→B	Load/Store
Secondary	ECC[25]	ECC[28]=0→A ECC[28]=1→B	Fill_I or Load/Store

4.22 Cache Management

To improve the performance of critical data movement operations in the embedded environment, the RM7065A significantly improves the speed of operation of certain critical cache management operations. In particular, the speed of the Hit-Writeback-Invalidate and Hit-Invalidate cache operations has been improved, in some cases by an order of magnitude, over that of other MIPS processors. For example, Table 8 compares the RM7065A with the R4000 processor.

Table 8 Penalty Cycles

Operation	Condition	Penalty	
		RM7065A	R4000
Hit-Writeback-Invalidate	Miss	0	7
	Hit-Clean	3	12
	Hit-Dirty	3+n	14+n
Hit-Invalidate	Miss	0	7
	Hit	2	9

For the Hit-Dirty case of Hit-Writeback-Invalidate in Table 8 above, if the writeback buffer is full from some previous cache eviction, then n is the number of cycles required to empty the writeback buffer. If the buffer is empty then n is zero.

The penalty value in Table 8 is the number of processor cycles beyond the one cycle required to issue the instruction that is required to implement the operation.

4.23 Primary Write Buffer

Writes to secondary cache or external memory, whether cache miss write-backs or stores to uncached or write-through addresses, use the integrated primary write buffer. The write buffer holds up to four 64-bit address and data pairs. The entire buffer is used for a data cache write-back and allows the processor to proceed in parallel with memory update. For uncached and write-through stores, the write buffer significantly increases performance by decoupling the **SysAD** bus transfers from the instruction execution stream.

4.24 System Interface

The RM7065A provides a high-performance 64-bit system interface which is compatible with the RM5200 Family. As an enhancement to the **SysAD** bus interface, the RM7065A allows half-

integral clock multipliers, thereby providing greater granularity when selecting pipeline and system interface frequencies.

The **SysAD** interface consists of a 64-bit Address/Data bus with 8 check bits and a 9-bit command bus. In addition, there are ten handshake signals and ten interrupt inputs. The interface is capable of transferring data between the processor and memory at a peak rate of 1000 MB/sec with a 125 MHz SysClock.

Figure 7 shows a typical embedded system using the RM7065A. This example shows a system with a bank of DRAMs and an interface ASIC which provides DRAM control as well as an I/O port.

Figure 7 Typical Embedded System Block Diagram

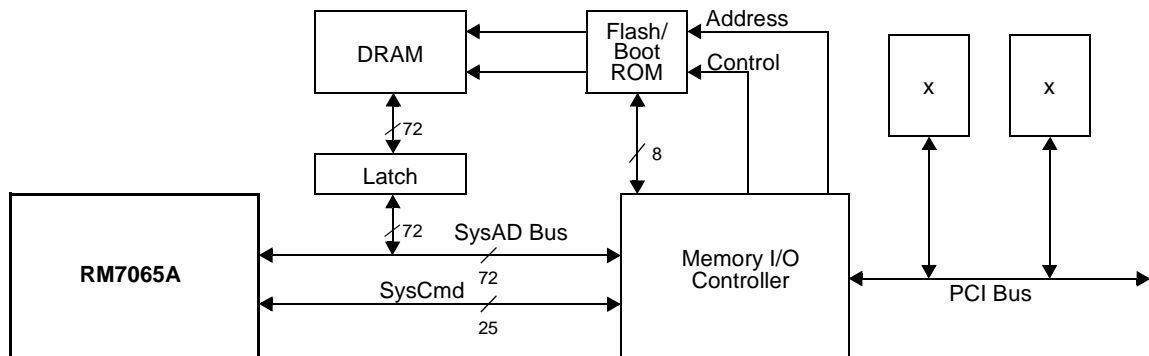

4.25 System Address/Data Bus

The 64-bit System Address Data (SysAD) bus is used to transfer addresses and data between the RM7065A and the rest of the system. It is protected with an 8-bit parity check bus, **SysADC[7:0]**.

The system interface is configurable to allow easy interfacing to memory and I/O systems of varying frequencies. The data rate and the bus frequency at which the RM7065A transmits data to the system interface are programmable at boot time via mode control bits. In addition, the rate at which the processor receives data is fully controlled by the external device. Therefore, either a low cost interface requiring no read or write buffering, or a faster, high-performance interface can be designed to communicate with the RM7065A.

4.26 System Command Bus

The RM7065A interface has a 9-bit System Command bus, **SysCmd[8:0]**. The command bus indicates whether the **SysAD** bus carries address or data information on a per-clock basis. If the **SysAD** bus carries address, the **SysCmd** bus indicates the transaction type (for example, a read or write). If the **SysAD** bus carries data, then the **SysCmd** bus contains information about the data (for example, this is the last data word transmitted, or the data contains an error). The **SysCmd** bus is bidirectional to support both processor requests and external requests to the RM7065A. Processor requests are initiated by the RM7065A and responded to by an external device. External requests are issued by an external device and require the RM7065A to respond.

The RM7065A supports one- to eight-byte transfers as well as 32-byte block transfers on the **SysAD** bus. In the case of a sub-doubleword transfer, the 3 low-order address bits give the byte address of the transfer, and the **SysCmd** bus indicates the number of bytes being transferred.

4.27 Handshake Signals

There are ten handshake signals on the system interface. Two of these, **RdRdy*** and **WrRdy***, are driven by an external device to indicate to the RM7065A whether it can accept a new read or write transaction. The RM7065A samples these signals before deasserting the address on read and write requests.

ExtRqst* and **Release*** are used to transfer control of the **SysAD** and **SysCmd** buses from the processor to an external device. When an external device requires control of the bus, it asserts **ExtRqst***. The RM7065A responds by asserting **Release*** to release the system interface to slave state.

PRqst* and **PAck*** are used to transfer control of the **SysAD** and **SysCmd** buses from the external agent to the processor. These two pins have been added to the **SysAD** interface to support multiple outstanding reads and facilitate non-blocking caches. When the processor needs to reacquire control of the interface, it asserts **PRqst***. The external device responds by asserting **PAck*** to return control of the interface to the processor.

RspSwap* is also a new pin and is used by the external agent to indicate to the processor when it is returning data out of order. For example, when there are two outstanding reads, the external agent asserts **RspSwap*** when it is going to return the data for the second read before it returns the data for the first read.

RdType is another new pin on the interface that indicates whether a read is an instruction read or a data read. When asserted, the reference is an instruction read. When deasserted it is a data read. **RdType** is only valid during valid address cycles.

ValidOut* and **ValidIn*** are used by the RM7065A and the external device respectively to indicate that there is a valid command or data on the **SysAD** and **SysCmd** buses. The RM7065A asserts **ValidOut*** when it is driving these buses with a valid command or data, and the external device drives **ValidIn*** when it has control of the buses and is driving a valid command or data.

4.28 System Interface Operation

To support non-blocking caches and data prefetch instructions, the RM7065A allows two outstanding reads. An external device may respond to read requests in whatever order it chooses by using the response order indicator pin **RspSwap***. No more than two read requests are submitted to the external device. Support for multiple outstanding reads can be enabled or disabled via a boot-time mode bit. Refer to Table 16 for a complete list of mode bits.

The RM7065A can issue read and write requests to an external device, while an external device can issue null and write requests to the RM7065A.

For processor reads, the RM7065A asserts **ValidOut*** and simultaneously drives the address and read command on the **SysAD** and **SysCmd** buses. If the system interface has **RdRdy*** asserted, then the processor tristates its drivers and releases the system interface to slave state by asserting **Release***. The external device can then begin sending data to the RM7065A.

Figure 8 shows a processor block read request and the corresponding external agent read response.

Figure 8 Processor Block Read

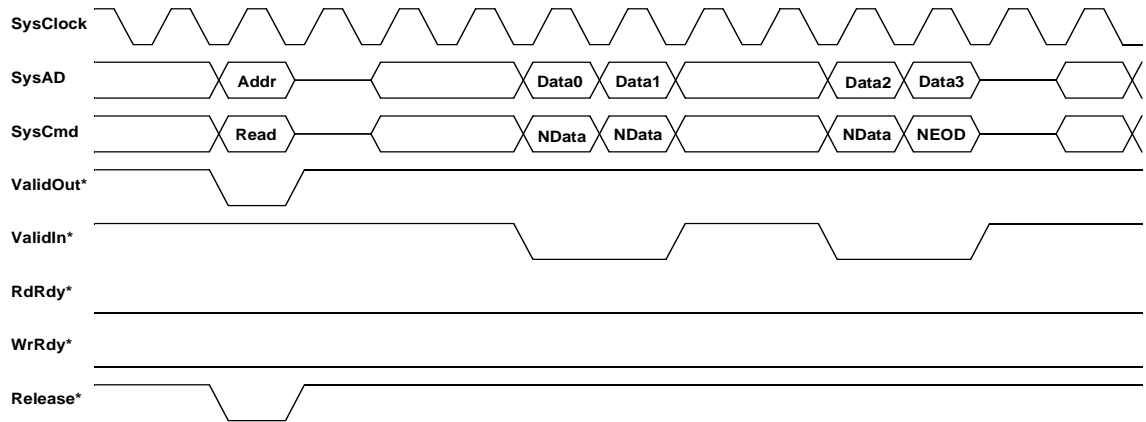

In Figure 8 the read latency is 4 cycles (**ValidOut*** to **ValidIn***), and the response data pattern is DDxxDD. Figure 9 shows a processor block write where the processor was programmed with write-back data rate boot code 2, or DDxxDDxx.

Finally, Figure 10 shows a typical sequence resulting in two outstanding reads, as explained in the following sequence.

1. The processor issues a read.
2. The external agent takes control of the bus in preparation for returning data to the processor.
3. The processor encounters another internal cache miss and therefore asserts **PRqst*** in order to regain control of the bus.
4. The external agent pulses **PAck***, returning control of the bus to the processor.
5. The processor issues a read for the second miss.
6. The **RspSwap*** pin is asserted to denote the out of order response. Not shown in the figure is the completion of the data transfer for the second miss, or any of the data transfer for the first miss.
7. The external agent retakes control of the bus and begins returning data (out of order) for the second miss to the processor

Figure 9 Processor Block Write

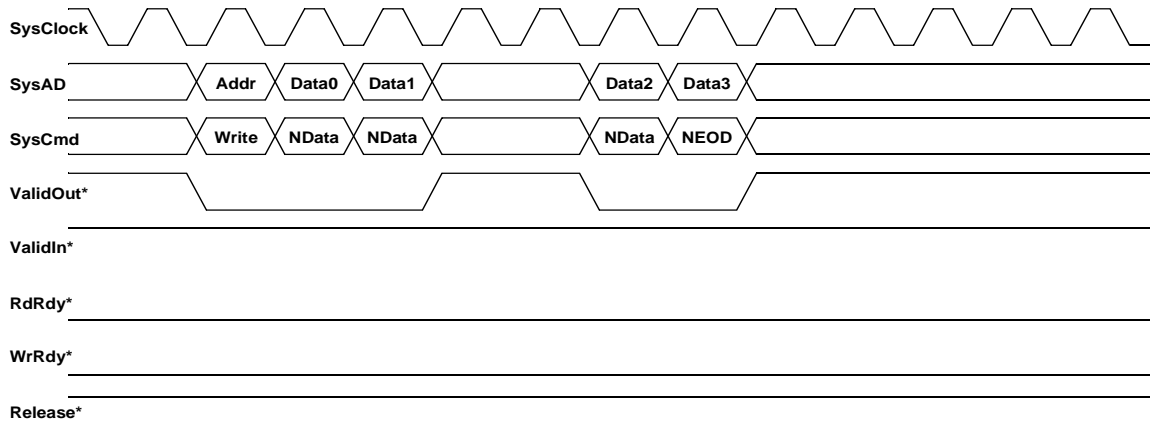
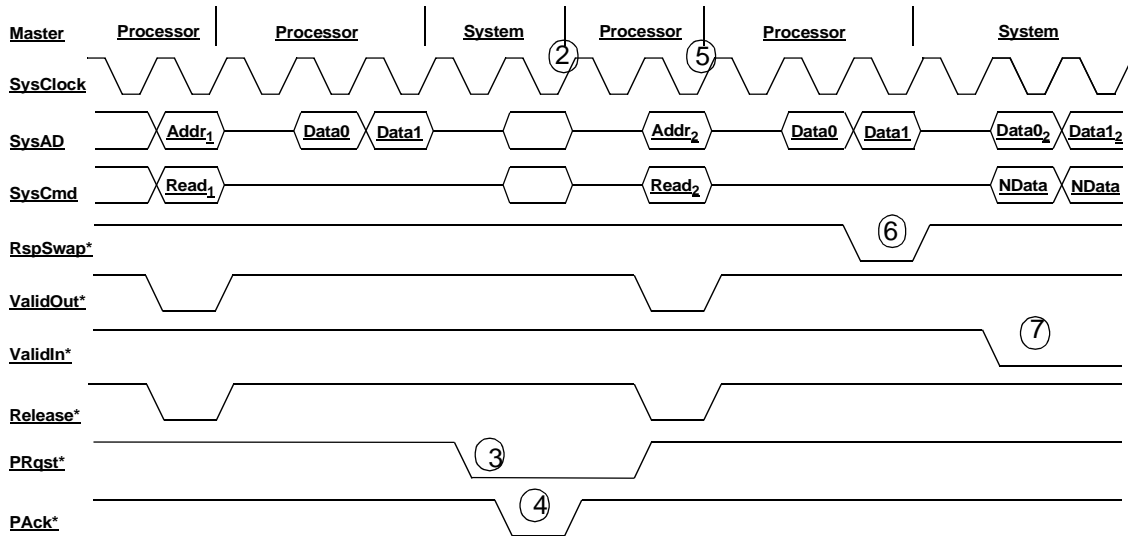

Figure 10 Multiple Outstanding Reads



4.29 Data Prefetch

The RM7065A is the first PMC-Sierra design to support the MIPS IV integer data prefetch (PREF) and floating-point data prefetch (PREFX) instructions. These instructions are used by the compiler or by an assembly language programmer when it is known or suspected that an upcoming data reference is going to miss in the cache. By appropriately placing a prefetch instruction, the memory latency can be hidden under the execution of other instructions. In cases where the execution of a prefetch instruction would cause a memory management or address error exception the prefetch is treated as a NOP.

The “Hint” field of the data prefetch instruction is used to specify the action taken by the instruction. The instruction can operate normally (that is, fetching data as if for a load operation) or it can allocate and fill a cache line with zeroes on a primary data cache miss.

4.30 Enhanced Write Modes

The RM7065A implements two enhancements to the original R4000 write mechanism: Write Reissue and Pipeline Writes. The original R4000 allowed a write on the **SysAD** bus every four **SysClock** cycles. Hence for a non-block write, this meant that two out of every four cycles were wait states.

Pipelined write mode eliminates these two wait states by allowing the processor to drive a new write address onto the bus immediately after the previous data cycle. This allows for higher **SysAD** bus utilization. However, at high frequencies the processor may drive a subsequent write onto the bus prior to the time the external agent deasserts **WrRdy***, indicating that it can not accept another write cycle. This can cause the cycle to be aborted.

Write reissue mode is an enhancement to pipelined write mode and allows the processor to reissue aborted write cycles. If **WrRdy*** is deasserted during the issue phase of a write operation, the cycle is aborted by the processor and reissued at a later time.

In write reissue mode, a rate of one write every two bus cycles can be achieved. Pipelined writes have the same two bus cycle write repeat rate, but can issue one additional write following the deassertion of **WrRdy***.

4.31 External Requests

The RM7065A can respond to certain requests issued by an external device. These requests take one of two forms: *Write* requests and *Null* requests. An external device executes a *write* request when it wishes to update one of the processors writable resources such as the internal interrupt register. A *null* request is executed when the external device wishes the processor to reassert ownership of the processor external interface. Once the external device has acquired control of the processor interface via **ExtRqst***, it can execute a null request after completing an independent transaction between itself and system memory in a system where memory is connected directly to the **SysAD** bus. Normally this transaction would be a DMA read or write from the I/O system.

4.32 Test/Breakpoint Registers

To facilitate hardware and software debugging, the RM7065A incorporates a pair of Test/Breakpoint, or Watch registers, called Watch1 and Watch2. Each Watch register can be separately enabled to watch for a load address, a store address, or an instruction address. All address comparisons are done on physical addresses. An associated register, Watch Mask, has also been added so that either or both of the Watch registers can compare against an address range rather than a specific address. The range granularity is limited to a power of two.

When enabled, a match of either Watch register results in an exception. If the Watch is enabled for a load or store address then the exception is the Watch exception as defined for the R4000 by Cause exception code twenty-three. If the Watch is enabled for instruction addresses then a newly defined *Instruction Watch* exception is taken and the Cause code is sixteen. The Watch register which caused the exception is indicated by Cause bits 25:24. Table 9 summarizes a Watch operation.

Table 9 Watch Control Register

Register	Bit Field/Function					
	63	62	61	60:36	35:2	1:0
Watch1, 2	Store	Load	Instr	0	Addr	0
	31:2				1	0
Watch Mask	Mask				Mask Watch 2	Mask Watch 1

Note that the *W1* and *W2* bits of the Cause register indicate which Watch register caused a particular Watch exception.

4.33 Performance Counters

To facilitate system tuning, the RM7065A implements a performance counter using two new CP0 registers, PerfCount and PerfControl. The PerfCount register is a 32-bit writable counter which causes an interrupt when bit 31 is set. The PerfControl register is a 32-bit register containing a 5-bit field which selects one of twenty-two event types as well as a handful of bits which control the overall counting function. Note that only one event type can be counted at a time and that counting can occur for user code, kernel code, or both. The event types and control bits are listed in Table 10.

Table 10 Performance Counter Control

PerfControl Field	Description
4:0	Event Type 00: Clock cycles 01: Total instructions issued 02: Floating-point instructions issued 03: Integer instructions issued 04: Load instructions issued 05: Store instructions issued 06: Dual issued pairs 07: Branch prefetches 08: External Cache Misses 09: Stall cycles 0A: Secondary cache misses 0B: Instruction cache misses 0C: Data cache misses 0D: Data TLB misses 0E: Instruction TLB misses 0F: Joint TLB instruction misses 10: Joint TLB data misses 11: Branches taken 12: Branches issued 13: Secondary cache writebacks 14: Primary cache writebacks 15: Dcache miss stall cycles (cycles where both cache miss tokens taken and a third address is requested) 16: Cache misses 17: FP possible exception cycles 18: Slip Cycles due to multiplier busy 19: Coprocessor 0 slip cycles 1A: Slip cycles due to pending non-blocking loads 1B: Write buffer full stall cycles 1C: Cache instruction stall cycles 1D: Multiplier stall cycles 1E: Stall cycles due to pending non-blocking loads - stall start of exception
7:5	Reserved (must be zero)
8	Count in Kernel Mode 0: Disable 1: Enable
9	Count in User Mode 0: Disable 1: Enable
10	Count Enable 0: Disable 1: Enable
31:11	Reserved (must be zero)

The performance counter interrupt only occurs when interrupts are enabled in the Status register, IE=1, and the **Interrupt Mask** bit 13 (**IM[13]**) of the coprocessor 0 interrupt control register is set.

Since the performance counter can be set up to count clock cycles, it can be used as either a second timer, or a watchdog interrupt. A watchdog interrupt can be used as an aid in debugging system or software “hangs.” Typically the software is setup to periodically update the count so that no interrupt occurs. When a hang occurs the interrupt ultimately triggers, thereby breaking free from the hang-up.

4.34 Interrupt Handling

In order to provide better real time interrupt handling, the RM7065A provides an extended set of hardware interrupts, each of which can be separately prioritized and separately vectored.

In addition to the standard six external interrupt pins, the RM7065A provides four more interrupt pins for a total of ten external interrupts.

As described above, the performance counter is also a hardware interrupt source using **Int[13]**. Historically in the MIPS architecture, interrupt 7 (**Int[7]**) was used as the timer interrupt. The RM7065A provides a separate interrupt, **Int[12]**, for this purpose, thereby releasing **Int[7]** for use as a pure external interrupt.

All interrupts (**Int[13:0]**), the Performance Counter, and the Timer, have corresponding interrupt mask bits, **IM[13..0]**, and interrupt pending bits, **IP[13..0]**, in the Status, Interrupt Control, and Cause registers. The bit assignments for the Interrupt Control and Cause registers are shown in Table 11 and Table 12. The Status register has not changed from the RM5200 Family and is not shown.

The *IV* bit in the Cause register is the global enable bit for the enhanced interrupt features. If this bit is clear then interrupt operation is compatible with the RM5200 Family.

In the Interrupt Control register, the interrupt vector spacing is controlled by the Spacing field as described below. The **Interrupt Mask** field (**IM[15:8]**) contains the interrupt mask for interrupts eight through thirteen. **IM[15:14]** are reserved for future use.

The **Timer Enable (TE)** bit is used to gate the Timer Interrupt to the Cause register. If **TE** is set to "0", the Timer Interrupt is not gated to **IP[12]**. If **TE** is set to "1", the Timer Interrupt is gated to **IP[12]**.

The setting for Mode Bit 11 is used to determine if the Timer Interrupt replaces the **External Interrupt (Int[5]*)** as an input to **IP[7]** in the Cause register. If Mode Bit 11 is set to "0", **Int[5]*** is gated to **IP[7]**. If Mode Bit 11 is set to "1", the Timer Interrupt is gated to **IP[7]**.

In order to utilize both **Int[5]*** and the internal Timer Interrupt, Mode Bit 11 must be set to "0" and **TE** must be set to "1". In this case, the Timer Interrupt will use **IP[12]**, and **Int[5]*** will use **IP[7]**. Refer to the logic diagram in the RM7000 User Manual for more information on the interrupt signals.

The Interrupt Control register uses **IMI3** to enable the Performance Counter Control.

Priority of the interrupts is set via two new coprocessor 0 registers called Interrupt Priority Level Lo (IPLLO) and Interrupt Priority Level Hi (IPLHI).

Table 11 Cause Register

31	30	29,28	27	26	25	24	23..8	7	6..2	0,1
BD	0	CE	0	W2	W1	IV	IP[15..0]	0	EXC	0

Table 12 Interrupt Control Register

31..16	15..8	7	6..5	4..0
0	IM[15..8]	TE	0	Spacing

Table 13 IPLLO Register

31..28	27..24	23..20	19..16	15..12	11..8	7..4	3..0
IPL7	IPL6	IPL5	IPL4	IPL3	IPL2	IPL1	IPL0

Table 14 IPLHI Register

31..28	27..24	23..20	19..16	15..12	11..8	7..4	3..0
0	0	IPL13	IPL12	IPL11	IPL10	IPL9	IPL8

In the IPLLO and IPLHI registers, each interrupt is represented by a four-bit field, thereby allowing each interrupt to be programmed with a priority level from 0 to 13 inclusive. The priorities can be set in any manner, including having all the priorities set exactly the same. Priority 0 is the highest level and priority 15 the lowest. The format of the priority level registers is shown in Table 13 and Table 14 above. The priority level registers are located in the coprocessor 0 control register space.

In addition to programmable priority levels, the RM7065A also permits the spacing between interrupt vectors to be programmed. For example, the minimum spacing between two adjacent vectors is 0x20 while the maximum is 0x200. This programmability allows the user to either set up the vectors as jumps to the actual interrupt routines or, if interrupt latency is paramount, to include the entire interrupt routine at one vector. Table 15 illustrates the complete set of vector spacing selections along with the coding as required in the *Interrupt Control register* bits 4:0.

In general, the active interrupt priority, combined with the spacing setting, generates a vector offset which is then added to the interrupt base address of 0x200 to generate the interrupt exception offset. This offset is then added to the exception base to produce the final interrupt vector address.

Table 15 Interrupt Vector Spacing

ICR[4..0]	Spacing
0x0	0x000
0x1	0x020
0x2	0x040
0x4	0x080
0x8	0x100
0x10	0x200
others	reserved

4.35 Standby Mode

The RM7065A provides a means to reduce the amount of power consumed by the internal core when the CPU is not performing any useful operations. This state is known as Standby Mode.

Executing the **WAIT** instruction enables interrupts and causes the processor to enter Standby Mode. If the **SysAD** bus is currently idle when the **WAIT** instruction completes the W pipe stage, the internal processor clock stops, thereby freezing the pipeline. The phase lock loop, or PLL, internal timer/counter, and the "wake up" input pins: **IP[9.0]***, **NMI***, **ExtReq***, **Reset***, and **ColdReset*** continue to operate in their normal fashion.

If the **SysAD** bus is not idle when the **WAIT** instruction completes the W pipe stage, then the **WAIT** is treated as a **NOP** until the bus operation is completed. Once the processor is in Standby, any interrupt, including the internally generated timer interrupt, causes the processor to exit Standby and resume operation where it left off. The **WAIT** instruction is typically inserted in the idle loop of the operating system or real time executive.

4.36 JTAG Interface

The RM7065A interface supports JTAG boundary scan in conformance with IEEE 1149.1. The JTAG interface is useful for checking the integrity of the processor's pin connections.

4.37 Boot-Time Options

The RM7065A operating modes are initialized at power-up by the boot-time mode control interface. The serial boot-time mode control interface operates at a very low frequency (**SysClock** divided by 256), allowing the initialization information to be kept in a low cost EPROM or system interface ASIC.

4.38 Boot-Time Modes

The boot-time serial mode stream is defined in Table 16. Bit 0 is presented to the processor as the first bit in the stream when **VccOK** is de-asserted. Bit 255 is the last bit transferred.

Table 16 Boot Time Mode Stream

Mode bit	Description	Mode bit	Description
0	Reserved: must be zero	17:16	System configuration identifiers - software visible in processor Config[21..20] register
4:1	Write-back data rate 0: DDDD 1: DDxDDx 2: DDxxDDxx 3: Dx Dx Dx Dx 4: DDxxxDDxxx 5: DDxxxxDDxxxx 6: DxxDxxDxxDxx 7: DDxxxxxxDDxxxxxx 8: DxxxDxxxDxxxDxxx 9-15: reserved	19:18	Reserved: Must be zero
7:5	SysClock to Pclock Multiplier Mode bit 20 = 0 / Mode bit 20 = 1 0: Multiply by 2/x 1: Multiply by 3/x 2: Multiply by 4/x 3: Multiply by 5/2.5 4: Multiply by 6/x 5: Multiply by 7/3.5 6: Multiply by 8/x 7: Multiply by 9/4.5	20	Pclock to SysClock multipliers. 0: Integer multipliers (2,3,4,5,6,7,8,9) 1: Half integer multipliers (2.5,3.5,4.5)
8	Specifies byte ordering. Logically ORed with BigEndian input signal. 0: Little endian 1: Big endian	23:21	Reserved: Must be zero
10:9	Non-Block Write Control 00: R4000 compatible non-block writes 01: reserved 10: pipelined non-block writes 11: non-block write re-issue	24	JTLB Size. 0: 48 dual-entry 1: 64 dual-entry
11	Timer Interrupt Enable/Disable 0: External <i>Int[5]</i> * gated to <i>IP[7]</i> 1: Internal Timer Interrupt gated to <i>IP[7]</i>	25	On-chip secondary cache control. 0: Disable 1: Enable
12	Reserved: Must be zero	26	Enable two outstanding reads with out-of-order return 0: Disable 1: Enable
14:13	Output driver strength - 100% = fastest 00: 67% strength 01: 50% strength 10: 100% strength 11: 83% strength	255:27	Reserved: Must be zero
15	Reserved: Must be zero		

5 Pin Descriptions

The following is a list of control, data, clock, interrupt, and miscellaneous pins of the RM7065A.

Table 17 System Interface

Pin Name	Type	Description
ExtRqst*	Input	External request Signals that the system interface is submitting an external request.
Release*	Output	Release interface Signals that the processor is releasing the system interface to slave state
RdRdy*	Input	Read Ready Signals that an external agent can now accept a processor read.
WrRdy*	Input	Write Ready Signals that an external agent can now accept a processor write request.
ValidIn*	Input	Valid Input Signals that an external agent is now driving a valid address or data on the SysAD bus and a valid command or data identifier on the SysCmd bus.
ValidOut*	Output	Valid output Signals that the processor is now driving a valid address or data on the SysAD bus and a valid command or data identifier on the SysCmd bus.
PRqst*	Output	Processor Request When asserted this signal requests that control of the system interface be returned to the processor. This is enabled by Mode Bit 26.
PAck*	Input	Processor Acknowledge When asserted, in response to PRqst*, this signal indicates to the processor that it has been granted control of the system interface.
RspSwap*	Input	Response Swap RspSwap* is used by the external agent to signal the processor when it is about to return a memory reference out of order; i.e., of two outstanding memory references, the data for the second reference is being returned ahead of the data for the first reference. Note that this signal works as a toggle; i.e., for each cycle that it is held asserted the order of return is reversed. By default, anytime the processor issues a second read it is assumed that the reads will be returned in order; i.e., no action is required if the reads are indeed returned in order. This is enabled by Mode Bit 26.
RdType	Output	Read Type During the address cycle of a read request, RdType indicates whether the read request is an instruction read or a data read.
SysAD(63:0)	Input/Output	System address/data bus A 64-bit address and data bus for communication between the processor and an external agent.

Pin Name	Type	Description
SysADC(7:0)	Input/Output	System address/data check bus An 8-bit bus containing parity check bits for the SysAD bus during data cycles.
SysCmd(8:0)	Input/Output	System command/data identifier bus A 9-bit bus for command and data identifier transmission between the processor and an external agent.
SysCmdP	Input/Output	System Command/Data Identifier Bus Parity For the RM7065A, unused on input and zero on output.

Table 18 Clock/Control Interface

Pin Name	Type	Description
SysClock	Input	System clock Master clock input used as the system interface reference clock. All output timings are relative to this input clock. Pipeline operation frequency is derived by multiplying this clock up by the factor selected during boot initialization
VccP	Input	Vcc for PLL Quiet VccInt for the internal phase locked loop. Must be connected to VccInt through a filter circuit.
VssP	Input	Vss for PLL Quiet Vss for the internal phase locked loop. Must be connected to VssInt through a filter circuit.

Table 19 Interrupt Interface

Pin Name	Type	Description
IP*(9:0)	Input	Interrupt Ten general processor interrupts, bit-wise ORed with bits 9:0 of the interrupt register.
NMI*	Input	Non-maskable interrupt Non-maskable interrupt, ORed with bit 15 of the interrupt register (bit 6 in R5000 compatibility mode).

Table 20 JTAG Interface

Pin Name	Type	Description
JTDI	Input	JTAG data in JTAG serial data in.
JTCK	Input	JTAG clock input JTAG serial clock input.
JTDO	Output	JTAG data out JTAG serial data out.
JTMS	Input	JTAG command JTAG command signal, signals that the incoming serial data is command data.

Table 21 Initialization Interface

Pin Name	Type	Description
BigEndian	Input	Big Endian / Little Endian Control Allows the system to change the processor addressing mode without rewriting the mode ROM.
VccOK	Input	Vcc is OK When asserted, this signal indicates to the RM7065A that the VccInt power supply has been above the recommended value for more than 100 milliseconds and will remain stable. The assertion of VccOK initiates the reading of the boot-time mode control serial stream.
ColdReset*	Input	Cold Reset This signal must be asserted for a power on reset or a cold reset. ColdReset must be de-asserted synchronously with SysClock.
Reset*	Input	Reset This signal must be asserted for any reset sequence. It may be asserted synchronously or asynchronously for a cold reset, or synchronously to initiate a warm reset. Reset must be de-asserted synchronously with SysClock.
ModeClock	Output	Boot Mode Clock Serial boot-mode data clock output at the system clock frequency divided by two hundred and fifty six.
ModeIn	Input	Boot Mode Data In Serial boot-mode data input.

6 Absolute Maximum Ratings¹

Symbol	Rating	Limits	Unit
V _{TERM}	Terminal Voltage with respect to VSS	-0.5 ² to +3.9	V
T _{CASE}	Operating Temperature	0 to +85	°C
T _{STG}	Storage Temperature	-55 to +125	°C
I _{IN}	DC Input Current ³	±20	mA
I _{OUT}	DC Output Current ⁴	±20	mA

Notes

1. Stresses greater than those listed under ABSOLUTE MAXIMUM RATINGS may cause permanent damage to the device. This is a stress rating only and functional operation of the device at these or any other conditions above those indicated in the operational sections of this specification is not implied. Exposure to absolute maximum rating conditions for extended periods may affect reliability.
2. V_{IN} minimum = -2.0 V for pulse width less than 15 ns. V_{IN} should not exceed 3.9 Volts.
3. When V_{IN} < 0V or V_{IN} > V_{ccIO}
4. Not more than one output should be shorted at a time. Duration of the short should not exceed 30 seconds.

7 Recommended Operating Conditions

CPU Speed	Temperature	Vss	Vcclnt	VccIO	VccP
300 - 350 MHz	0°C to +85°C (Case)	0V	1.65V ± 50 mV	3.3 V ± 150 mV or 2.5 V ± 200 mV	1.65V ± 50 mV

Notes

1. VccIO should not exceed Vcclnt by greater than 2.0 V during the power-up sequence.
2. Applying a logic high state to any I/O pin before Vcclnt becomes stable is not recommended.
3. As specified in IEEE 1149.1 (JTAG), the JTMS pin must be held high during reset to avoid entering JTAG test mode. Refer to the RM7065A Family Users Manual, Appendix E.
4. VccP must be connected to Vcclnt through a passive filter circuit. See RM7000 Family User's Manual for recommended circuit.

8 DC Electrical Characteristics

($V_{ccIO} = 3.15V - 3.45V$)

Parameter	Minimum	Maximum	Conditions
V_{OL}		0.2V	$ I_{OUT} = 100 \mu A$
V_{OH}	$V_{ccIO} - 0.2V$		
V_{OL}		0.4V	$ I_{OUT} = 2 \text{ mA}$
V_{OH}	2.4V		
V_{IL}	-0.3V	0.8V	
V_{IH}	2.0V	$V_{ccIO} + 0.3V$	
I_{IN}		$\pm 15 \mu A$ $\pm 15 \mu A$	$V_{IN} = 0$ $V_{IN} = V_{ccIO}$

($V_{ccIO} = 2.3V - 2.7V$)

Parameter	Minimum	Maximum	Conditions
V_{OL}		0.2V	$ I_{OUT} = 100 \mu A$
V_{OH}	2.1V		
V_{OL}		0.4V	$ I_{OUT} = 1 \text{ mA}$
V_{OH}	2.0		
V_{OL}		0.7V	$ I_{OUT} = 2 \text{ mA}$
V_{OH}	1.7		
V_{IL}	-0.3V	0.7V	
V_{IH}	1.7V	$V_{ccIO} + 0.3V$	
I_{IN}		$\pm 15 \mu A$ $\pm 15 \mu A$	$V_{IN} = 0$ $V_{IN} = V_{ccIO}$

9 Power Consumption

Parameter		Conditions	CPU Speed		
			300 MHz	350 MHz	TBD MHz
			Max ¹	Max ¹	Max ¹
Vcclnt Power (mWatts)	standby		TBD	TBD	TBD
	active	Maximum with no FPU operation ²	TBD	TBD	TBD
		Maximum worst case instruction mix	TBD	TBD	TBD

Notes

1. Worst case supply voltage (maximum Vcclnt) with worst case temperature (maximum TCase).
2. Dhrystone 2.1 instruction mix.
3. I/O supply power is application dependant, but typically <20% of Vcclnt.

10 AC Electrical Characteristics

10.1 Capacitive Load Deration

Parameter	Symbol	Min	Max	Units
Load Derate	C_{LD}		2	ns/25pF

10.2 Clock Parameters

Parameter	Symbol	Test Conditions	CPU Speed						Units
			300 MHz		350 MHz		TBD MHz		
			Min	Max	Min	Max	Min	Max	
SysClock High	t_{SCHigh}	Transition $\leq 5ns$	3		3				ns
SysClock Low	t_{SCLow}	Transition $\leq 5ns$	3		3				ns
SysClock Frequency			33.3	100	33.3	117			MHz
SysClock Period	t_{SCP}		10	30	8.5	30			ns
Clock Jitter for SysClock	$t_{jitterIn}$			± 150		± 150			ps
SysClock Rise Time	t_{SCRise}			2		2			ns
SysClock Fall Time	t_{SCFall}			2		2			ns
ModeClock Period	$t_{ModeCKP}$			256		256			t_{SCP}
JTAG Clock Period	$t_{JTAGCKP}$		4		4				t_{SCP}

Note

1. Operation of the RM7065A is only guaranteed with the Phase Lock Loop Enabled.

10.3 System Interface Parameters

Parameter ¹	Symbol	Test Conditions	CPU Speed						Units
			300 MHz		350 MHz		TBD MHz		
			Min	Max	Min	Max	Min	Max	
Data Output ^{2,3}	t _{DO}	mode14..13 = 10 ^{5,6} (fastest)	1.0	TBD	TBD	TBD	TBD	TBD	ns
		mode14..13 = 01 ^{5,6} (slowest)	1.0	TBD	TBD	TBD	TBD	TBD	ns
Data Setup ⁴	t _{DS} ⁶	t _{rise} = see above table	2.5		TBD		TBD		ns
Data Hold ⁴	t _{DH}	t _{fall} = see above table	1.0		TBD		TBD		ns

Notes

1. Timings are measured from 0.425 x V_{ccIO} of clock to 0.425 x V_{ccIO} of signal for 3.3 V I/O. Timings are measured from 0.48 x V_{ccIO} of clock to 0.48 x V_{ccIO} of signal for 2.5 V I/O.
2. Capacitive load for all output timings is 50 pF.
3. Data Output timing applies to all signal pins whether tristate I/O or output only.
4. Setup and Hold parameters apply to all signal pins whether tristate I/O or input only.
5. Only mode 14:13 = 10 is tested and guaranteed.
6. Data shown is for 3.3 V I/O. For 2.5 V I/O derate all times by 0.5 nS.

10.4 Boot-Time Interface Parameters

Parameter	Symbol	Min	Max	Units
Mode Data Setup	t _{DS}	4		SysClock cycles
Mode Data Hold	t _{DH}	0		SysClock cycles

11 Timing Diagrams

11.1 Clock Timing

Figure 11 Clock Timing

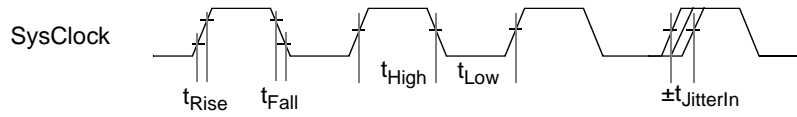

System Interface Timing (SysAD, SysCmd, ValidIn*, ValidOut*, etc.)

Figure 12 Input Timing

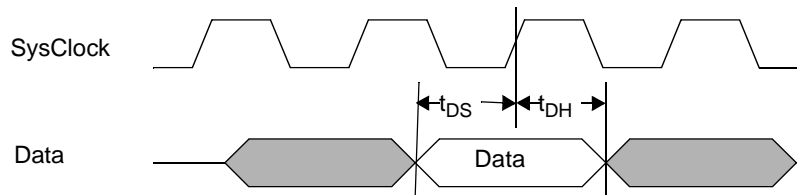
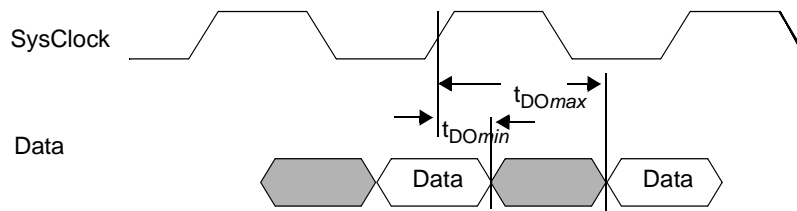
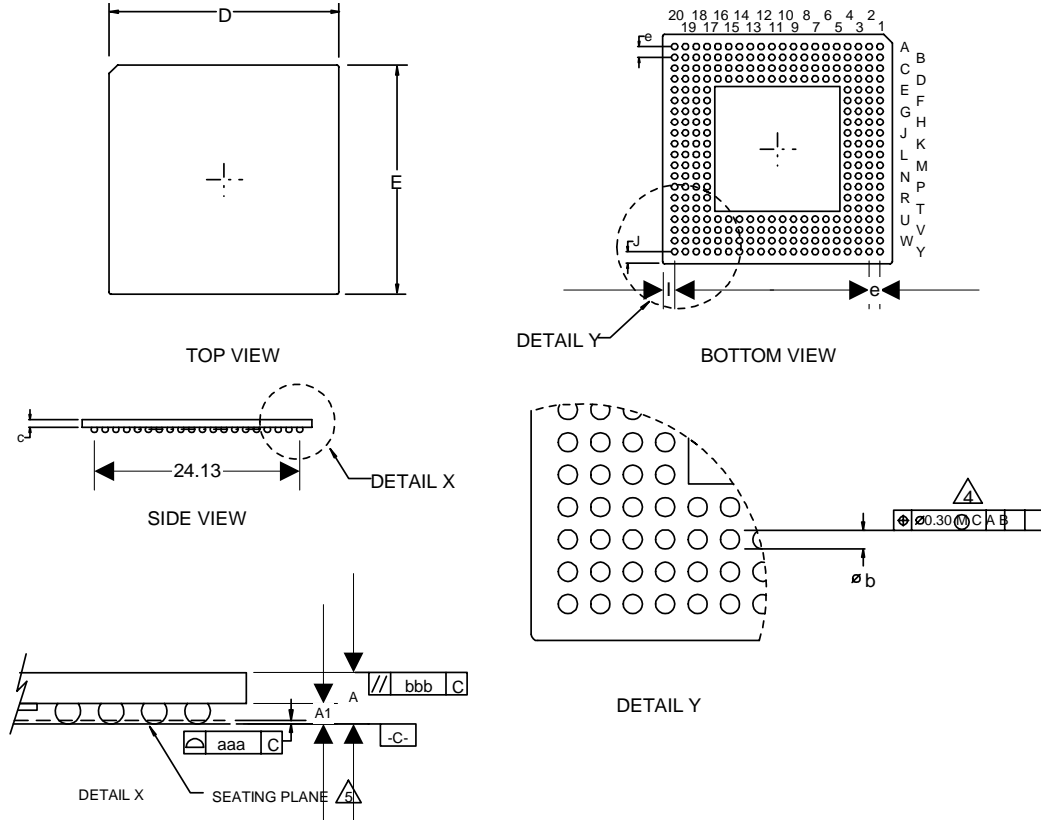

Figure 13 Output Timing



12 Packaging Information

Figure 14 Mechanical Diagram



Symbol	Min.	Nom.	Max.
A ⁸	—	—	1.70
A1	0.50	0.60	0.70
D	—	27.00	—
E	—	27.00	—
I	1.435 REF.		
J	1.435 REF.		
M	20 <PERIMETER>		
aaa			0.20
bbb			0.25
b	0.60	0.75	0.90
c	0.80	0.90	1.00
e	1.27 TYP.		

Notes

1. Package Dimensions conform to JEDEC Registration MO-149(BG-2X).
2. "e" represents the basic solder ball grid pitch.

3. "M" represents the maximum solder ball matrix size.
- ④ "Dimension "b" is measured at the maximum solder ball diameter parallel to the primary datum "c".
- ⑤ The Primary datum "c" and the seating plane are defined by the spherical crowns of the solder balls.
6. All dimensions are in millimeters.
- ⑦ Dimensioning and tolerancing per ASME Y14.5M-1994.
8. After surface mount assembly, solder ball will have 0.15 mm (TYP) collapse in "A" dimension.
9. Substrate base material is copper.
10. Package top surface color shall be black.
11. Cavity depth maximum is 0.50 mm.

13 RM7065A Pinout

Pin	Function	Pin	Function	Pin	Function	Pin	Function
A1	VccIO	A2	VSS	A3	VSS	A4	Do Not Connect
A5	SysAD[35]	A6	VSS	A7	SysAD[33]	A8	SysAD[32]
A9	VSS	A10	SysADC[1]	A11	Do Not Connect	A12	VSS
A13	SysADC[2]	A14	SysAD[62]	A15	VSS	A16	SysAD[60]
A17	Do Not Connect	A18	VSS	A19	VSS	A20	VccIO
B1	VSS	B2	VccIO	B3	VSS	B4	VSS
B5	Do Not Connect	B6	SysAD[3]	B7	SysAD[2]	B8	SysAD[1]
B9	SysADC[5]	B10	SysADC[0]	B11	SysADC[3]	B12	SysADC[6]
B13	Do Not Connect	B14	SysAD[30]	B15	SysAD[29]	B16	Do Not Connect
B17	VSS	B18	VSS	B19	VccIO	B20	VSS
C1	VSS	C2	VSS	C3	VccIO	C4	Do Not Connect
C5	Do Not Connect	C6	Do Not Connect	C7	SysAD[34]	C8	VccInt
C9	SysAD[0]	C10	SysADC[4]	C11	SysADC[7]	C12	VccInt
C13	SysAD[31]	C14	SysAD[61]	C15	VccInt	C16	Do Not Connect
C17	Do Not Connect	C18	VccIO	C19	VSS	C20	VSS
D1	Do not Connect	D2	VSS	D3	Do not Connect	D4	VccIO
D5	VccIO	D6	Do Not Connect	D7	VccInt	D8	VccInt
D9	VccIO	D10	VccInt	D11	VccInt	D12	VccIO
D13	SysAD[63]	D14	VccInt	D15	SysAD[28]	D16	VccIO
D17	VccIO	D18	Do Not Connect	D19	VSS	D20	Do Not Connect
E1	SysAD[5]	E2	Do Not Connect	E3	VccInt	E4	VccIO
E17	VccIO	E18	Do Not Connect	E19	Do Not Connect	E20	SysAD[59]
F1	VSS	F2	SysAD[36]	F3	SysAD[4]	F4	VccInt
F17	VccInt	F18	SysAD[27]	F19	SysAD[58]	F20	VSS
G1	SysAD[38]	G2	SysAD[6]	G3	SysAD[37]	G4	VccInt
G17	VccInt	G18	SysAD[26]	G19	SysAD[57]	G20	SysAD[25]
H1	SysAD[7]	H2	SysAD[39]	H3	SysAD[40]	H4	SysAD[8]
H17	SysAD[24]	H18	SysAD[56]	H19	SysAD[55]	H20	SysAD[23]
J1	VSS	J2	SysAD[9]	J3	VccInt	J4	VccIO
J17	VccIO	J18	SysAD[54]	J19	SysAD[22]	J20	VSS
K1	SysAD[41]	K2	SysAD[10]	K3	SysAD[42]	K4	SysAD[11]
K17	SysAD[53]	K18	SysAD[21]	K19	SysAD[52]	K20	SysAD[20]
L1	SysAD[43]	L2	SysAD[44]	L3	SysAD[12]	L4	VccInt
L17	VccInt	L18	SysAD[51]	L19	SysAD[19]	L20	SysAD[50]
M1	VSS	M2	SysAD[13]	M3	SysAD[45]	M4	VccIO
M17	VccIO	M18	SysAD[18]	M19	SysAD[49]	M20	VSS
N1	SysAD[14]	N2	SysAD[46]	N3	VccInt	N4	SysAD[47]
N17	VccInt	N18	SysAD[48]	N19	SysAD[16]	N20	SysAD[17]

Pin	Function	Pin	Function	Pin	Function	Pin	Function
P1	SysAD[15]	P2	RSPSWAPB	P3	PACKB	P4	VccInt
P17	ColdResetB	P18	VccOK	P19	BigEndian	P20	ResetB
R1	VSS	R2	Do Not Connect	R3	JTDI	R4	JTCK
R17	VccInt	R18	ExtrQSTB	R19	NMIB	R20	VSS
T1	PRQSTB	T2	JTDO	T3	VccIO	T4	VccIO
T17	VccIO	T18	VccInt	T19	Int[9]*	T20	Int[8]*
U1	ModeClock	U2	VSS	U3	JTMS	U4	VccIO
U5	VccIO	U6	ValidInB	U7	VSSP	U8	VccInt
U9	VccIO	U10	VccInt	U11	VccInt	U12	VccIO
U13	SysCmd[7]	U14	VccInt	U15	Int[3]*	U16	VccIO
U17	VccIO	U18	Int[6]*	U19	VSS	U20	Int[7]*
V1	VSS	V2	VSS	V3	VccIO	V4	RDType
V5	RDRDYB	V6	VccP	V7	Do Not Connect	V8	VccInt
V9	Do Not Connect	V10	Do Not Connect	V11	VccInt	V12	SysCmd[3]
V13	SysCmd[6]	V14	VccInt	V15	Int[2]*	V16	Int[5]*
V17	Int[4]*	V18	VccIO	V19	VSS	V20	VSS
W1	VSS	W2	VccIO	W3	VSS	W4	VSS
W5	WRRDYB	W6	ReleaseB	W7	SysClk	W8	VccInt
W9	Do Not Connect	W10	Do Not Connect	W11	SysCmd[1]	W12	SysCmd[2]
W13	SysCmd[5]	W14	SysCmdP	W15	VccInt	W16	Int[1]*
W17	VSS	W18	VSS	W19	VccIO	W20	VSS
Y1	VccIO	Y2	VSS	Y3	VSS	Y4	Modeln
Y5	ValidOutB	Y6	VSS	Y7	VccP	Y8	Do Not Connect
Y9	VSS	Y10	Do Not Connect	Y11	SysCmd[0]	Y12	VSS
Y13	SysCmd[4]	Y14	SysCmd[8]	Y15	VSS	Y16	Do Not Connect
Y17	Int[0]*	Y18	VSS	Y19	VSS	Y20	VccIO

14 Ordering Information

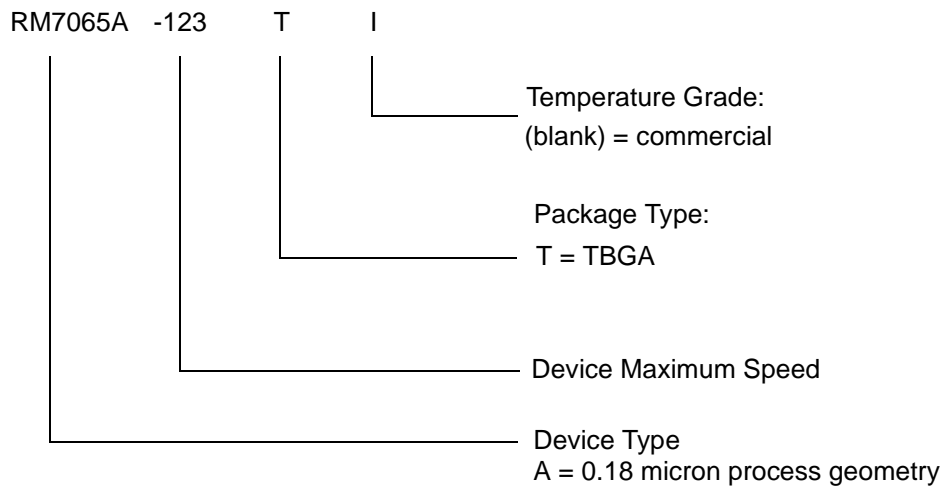

Valid Combinations

RM7065A-300T

RM7065A-350T