

INTRODUCTION

The KA2410/KA2411 is a bipolar integrated circuit designed for telephone bell replacement.

FUNCTIONS

- Two oscillators
- Output amplifier
- Power supply control circuit

FEATURES

- Designed for telephone bell replacement
- Low current drain.
- Small size 'MINIDIP' package.
- Adjustable 2-frequency tone.
- Adjustable warbling rate.
- Built-in hysteresis prevents false triggering and rotary dial 'CHIRPS'.
- Extension tone ringer modules.
- Alarms or other alerting devices.
- External triggering or ringer disable. (KA2410)
- Adjustable for reduced initial supply current. (KA2411)

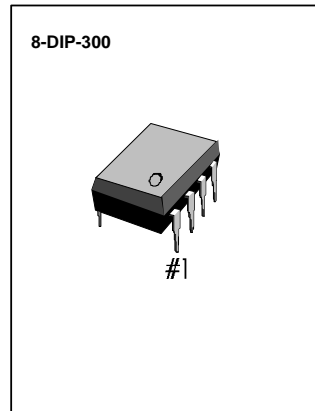

ORDERING INFORMATION

Device	Package	Operating Temperature
KA2410	8-DIP-300	- 45°C ~ + 65°C
KA2411		

PIN CONFIGURATION

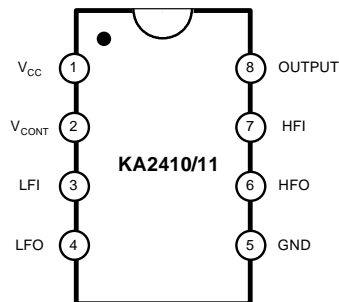

Fig. 1



ABSOLUTE MAXIMUM RATINGS

Characteristic	Symbol	Value	Unit
Supply Voltage	V_{CC}	30	V
Power Dissipation	P_D	400	mW
Operating Temperature	T_{OPR}	- 45 ~ 65	°C
Storage Temperature	T_{STG}	- 65 ~ 150	°C

ELECTRICAL CHARACTERISTICS ($T_a = 25^\circ\text{C}$)

(All voltage referenced to GND unless otherwise specified)

Characteristic	Symbol	Test Conditions	Min	Typ	Max	Unit
Operating Voltage	V_{CC}	-	-	-	29.0	V
Initiation Voltage ¹	V_{SI}	See Fig. 2	17	19	21	V
Initiation Current ¹	I_{SI}	KA2411-6.8K-Pin 2 to GND	1.4	2.5	4.2	mA
Sustaining Voltage ²	V_{SUS}	See Fig. 2	9.7	11.0	12.0	V
Sustaining Current ²	I_{SUS}	No Load $V_{CC} = V_{SUS}$, See Fig. 2	0.7	1.4	2.5	mA
Trigger Voltage ³	V_{TRG}	KA2410 Only $V_{CC} = 15\text{V}$	9.0	10.5	12.0	V
Trigger Current ³	I_{TRG}	KA2410 Only	10.0	20.0	1000 ⁵	μA
Disable Voltage ⁴	V_{DIS}	KA2410 Only	-	-	0.8	V
Disable Current ⁴	I_{DIS}	KA2410 Only	- 40	- 50	-	μA
Output Voltage High	V_{OH}	$V_{CC} = 21\text{V}$, $I_B = -15\text{mA}$ Pin 6 = 6V, Pin 7 = GND	17.0	19.0	21.0	V
Output Voltage Low	V_{OL}	$V_{CC} = 21\text{V}$, $I_B = 15\text{mA}$ Pin 6 = GND, Pin 7 = 6V	-	-	1.6	V
Input Current 1 (Pin 3)	$I_{I(PIN 3)}$	Pin 3 = 6V, Pin 4 = GND	-	-	500	nA
Input Current 2 (Pin 7)	$I_{I(PIN 7)}$	Pin 7 = 6V, Pin 6 = GND	-	-	500	nA
High Frequency 1	f_{H1}	$R_3 = 191\text{K}$, $C_3 = 6800\text{pF}$	461	512	563	Hz
High Frequency 2	f_{H2}	$R_3 = 191\text{K}$, $C_3 = 6800\text{pF}$	576	640	704	Hz
Low Frequency	f_L	$R_2 = 165\text{K}$, $C_2 = 0.47\mu\text{F}$	9.0	10	11.0	Hz

• NOTE (see electrical characteristics sheet)

1. Initial supply voltage (V_{SI}) is the supply voltage required to start the tone ringer oscillating.
2. Sustaining voltage (V_{SUS}) is the supply voltage required to maintain oscillation.
3. V_{TR} and I_{TR} are the conditions applied to trigger in to start oscillation for $V_{SUS} \leq V_{CC} \leq V_{SI}$
4. V_{DIS} and I_{DIS} are the conditions applied to trigger in to inhibit oscillation for $V_{SI} \leq V_{CC}$
5. Trigger current must be limited to this value externally.



GRAPH

KA2410 Supply Current (No Load) Vs. Supply Voltage

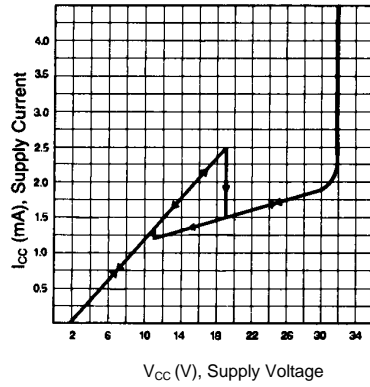

Fig. 2

KA2411 Supply Current (No Load) Vs. Supply Voltage

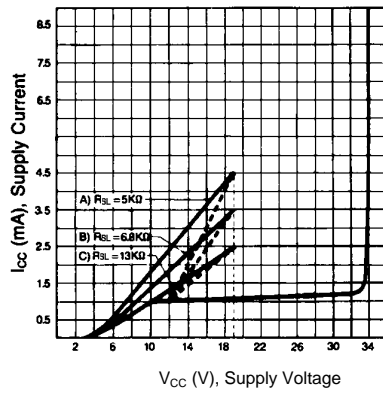

Fig. 3



APPLICATION INFORMATION

The application circuit illustrates the use of the KA2410/1 devices in typical telephone or extensive tone ringer applications. The AC ringer signal voltage appears across the TIP and RING inputs of the circuit and is attenuated by capacitor C_1 and resistor R_1 .

C_1 also provides isolation from DC voltages (48V) on the exchange line.

After full wave rectification by the bridge diode, the waveform is filtered by capacitor C_4 to provide a DC supply for the tone ringer chip.

When this voltage exceeds the initiation (V_{SI}), oscillation starts.

With the components shown, the output frequency chops between 512 Hz (f_{H1}) and 640Hz (f_{H2}) at a 10Hz (f_L) rate.

The loudspeaker load is coupled through a 1300 Ω to 8 Ω transformer.

The output coupling capacitor C_5 is required with transformer coupled loads.

When driving a piezo-ceramic transducer type load, the coupling C_5 and transformer (1300 Ω : 8 Ω) are not required.

However, a current limiting resistor is required.

The low frequency oscillator oscillates at a rate (f_L) controlled by an external resistor (R_2) and capacitor (C_2). The frequency can be determined using the relation $f_L = 1/(1.289 R_2 \cdot C_2)$. The high frequency oscillates at a f_{H1} , f_{H2} controlled by an external resistor (R_3) and capacitor (C_3). The frequency can be determined using the relation $t_{HI} = 1/(1.504 R_3 \cdot C_3)$ voltage remains constant independent of R_{SL} .

Pin 2 of the KA2411 allows connection of an external resistor R_{SL} , which is used to program the slope of the supply current vs supply voltage characteristics (see Fig. 3) and hence the supply current up to the initial voltage (V_{SI}). This initial voltage remains constant independent of R_{SL} .

The supply current drawn prior to triggering varies inversely with R_{SL} , decreasing for an increasing value of resistance. Thus, increasing the value of R_{SL} , will decrease the amount of AC ringing current required to trigger the device. As such longer subscriber loops are possible since less voltage is dropt per unit length of loop wire due to the lower current level. R_{SL} can also be used to compensate for smaller AC coupling capacitors (C_5 on Fig. 5) (higher impedance) to the line which is used to alter the ringer equivalence number of a tone ringer circuit.

The graph in Fig. 3 illustrates the variation of supply current with supply voltage of the KA2411. Three curves are drawn to show the variation of initiation current with R_{SL} . Curve B ($R_{SL} = 6.8K\Omega$) shows the I-V characteristic for the KA2411 tone ringer. Curve A is a plot with $R_{SL} < 6.8K\Omega$ and shows an increase in the current drawn up to the initiation voltage V_{SI} . After initiation, the I-V characteristic remain unchanged. Curve C illustrates the effect of increasing R_{SL} above 6.8K Ω initiation current decreases but is unchanged again after triggering.

APPLICATION CIRCUIT 1 (KA2410)

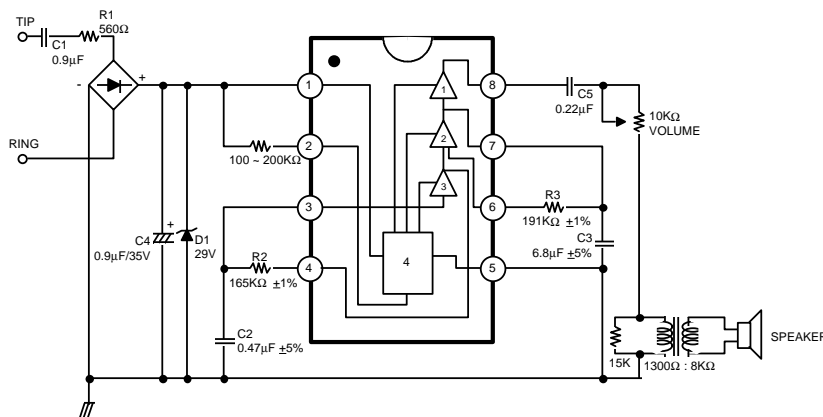

- Note : 1. Output amplifier
 2. High frequency oscillator
 3. Low frequency oscillator
 4. Hysteresis regulator

Fig. 4

APPLICATION CIRCUIT 2 (KA2411)

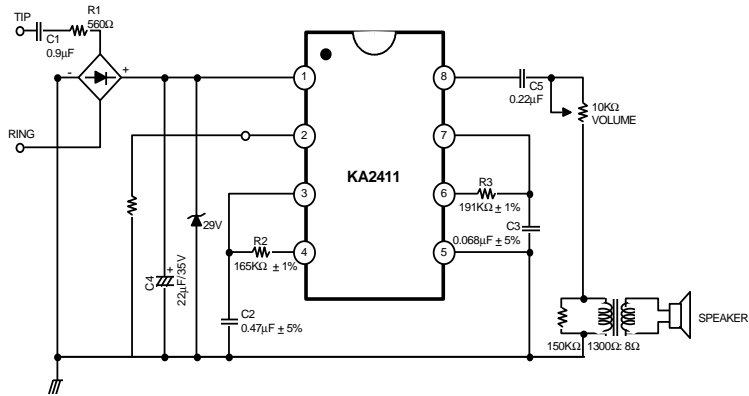

Fig. 5

EQUIVALENT CIRCUIT
(Pin 2 Input)

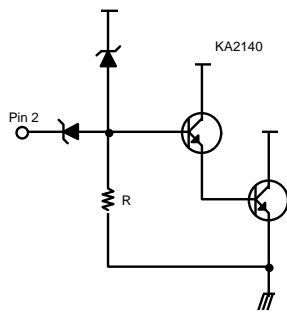

Fig. 6

INHIBITING OSCILLATION

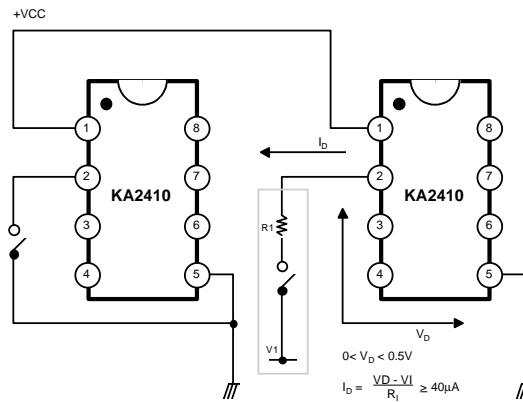

Fig. 7



TRIGGERING THE KA2410 FROM CMOS OR TTL LOGIC

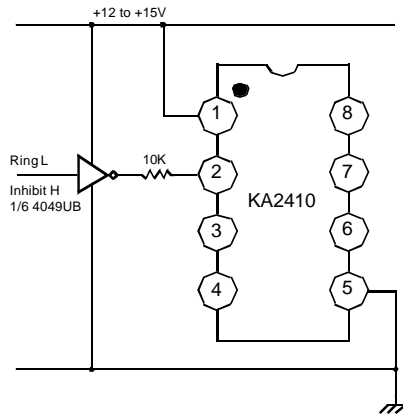

Fig. 8

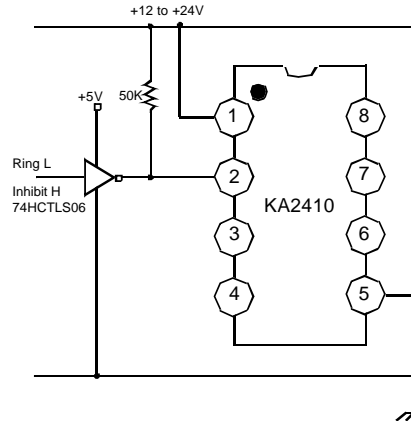

Fig. 9

PROGRAMMING THE KA2410 INITIATION SUPPLY VOLTAGE

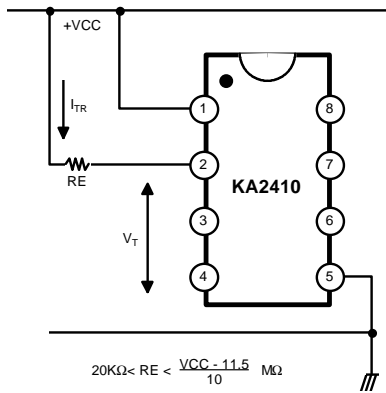

Fig. 10

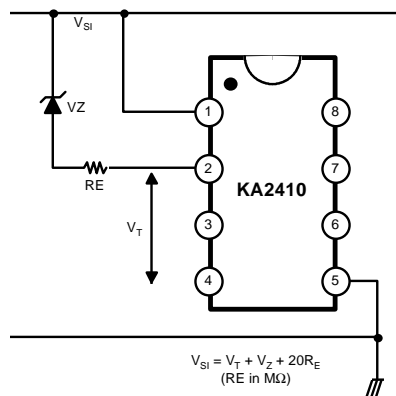

Fig. 11

