



**Winbond W55Fxx**

**Serial Flash Memory**

**Data Sheet**

## Contents

<b>General Description</b>	<b>2</b>
1.1 W55Fxx Product Selection Guide.....	2
<b>Features</b>	<b>3</b>
2.1 W55Fxx Features Description.....	3
2.2 W55Fxx Pin Configuration & Description.....	4
2.3 W55Fxx System Block Diagram.....	5
<b>Electrical Characteristics</b>	<b>6</b>
3.1 W55Fxx Absolute Maximum Ratings.....	6
3.2 W55Fxx DC Characteristics.....	6
3.3 W55Fxx AC Characteristics.....	7
<b>Timing Waveform</b>	<b>8</b>
4.1 W55Fxx Timing Waveform .....	8
<b>Applications</b>	<b>9</b>
5.1 W55Fxx Applications .....	9
5.2 W55Fxx Application Circuits .....	10



## General Description

The W55Fxx is a serial flash memory series that is typically used as the contents upgradeable memory device of Internet toy applications, or applications with W51300 (*VoiceRecorder™* controller) for voice message storage device. Besides that, W55Fxx can still be the W551Cxxx (Serial Voice Memory) program or data emulator. The single voltage supply eliminates the need for an extra pump circuit during flash memory cells programming and erasing.

---

### 1.1 W55Fxx Product Selection Guide

W55Fxx Serial Flash Memory is used to store pre-determined data or contents need to be upgradeable applications. To communicate with W55Fxx in serial data mode, the connection interface total pin counts can be reduced to five pins only. The following table is shown the product selection guide of part number vs. memory density.

Part #	W55F01	W55F05	W55F10A	W55F20
Density	128K bits	512K bits	1M bits	2M bits

# Features

---

## 2.1 W55Fxx Features Description

- ❑ Provides CLK, ADDR, and DATA connection interface pins to communicate with other controllers such as Winbond *PowerSpeech<sup>TM</sup>*, *BandDirector<sup>TM</sup>*, *ViewTalk<sup>TM</sup>*, ..... Series.
- ❑ 128K/512K/1M/2M bits memory density available.
- ❑ Directly cascadable for longer duration applications ( except for W55F01).
- ❑ Fast frame-write operation
  - Frame (32 bits) program cycle time: **400  $\mu$ S (typ.)**
- ❑ Fast whole-chip-erase duration: **50 mS (max.)**
- ❑ Read data access time: **500 nS (max.)**
- ❑ Program/erase cycles: **10,000 (typ.)**
- ❑ Data retention: **10 years (typ.)**
- ❑ Low power consumption:
  - Operating: **5 mA (typ.)**
  - Standby: **2  $\mu$ A (typ.)**

## 2.2 W55Fxx Pin Configuration & Description

### Pin Configuration

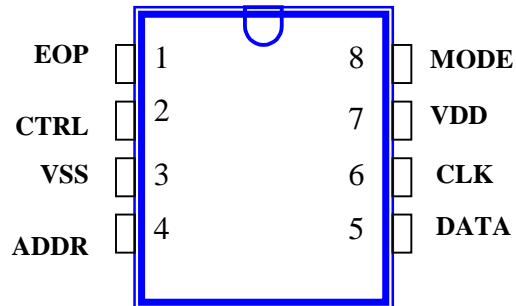

### Pin Description

No.	Pin Name	I/O	Description
1	EOP	O	End of process signal output.
2	CTRL	I	Enable signal for program and erase operations when MODE = 0, Input clock for mode counter when MODE = 1.
3	VSS	I	Ground
4	ADDR	I	Input clock for start address shift-in.
5	DATA	I/O	Bi-directional data line.
6	CLK	I	Input clock for data write-in and read-out.
7	VDD	I	Positive voltage supply.
8	MODE	I	Mode select control pin.

## 2.3 W55Fxx System Block Diagram

W55Fxx Block Diagram

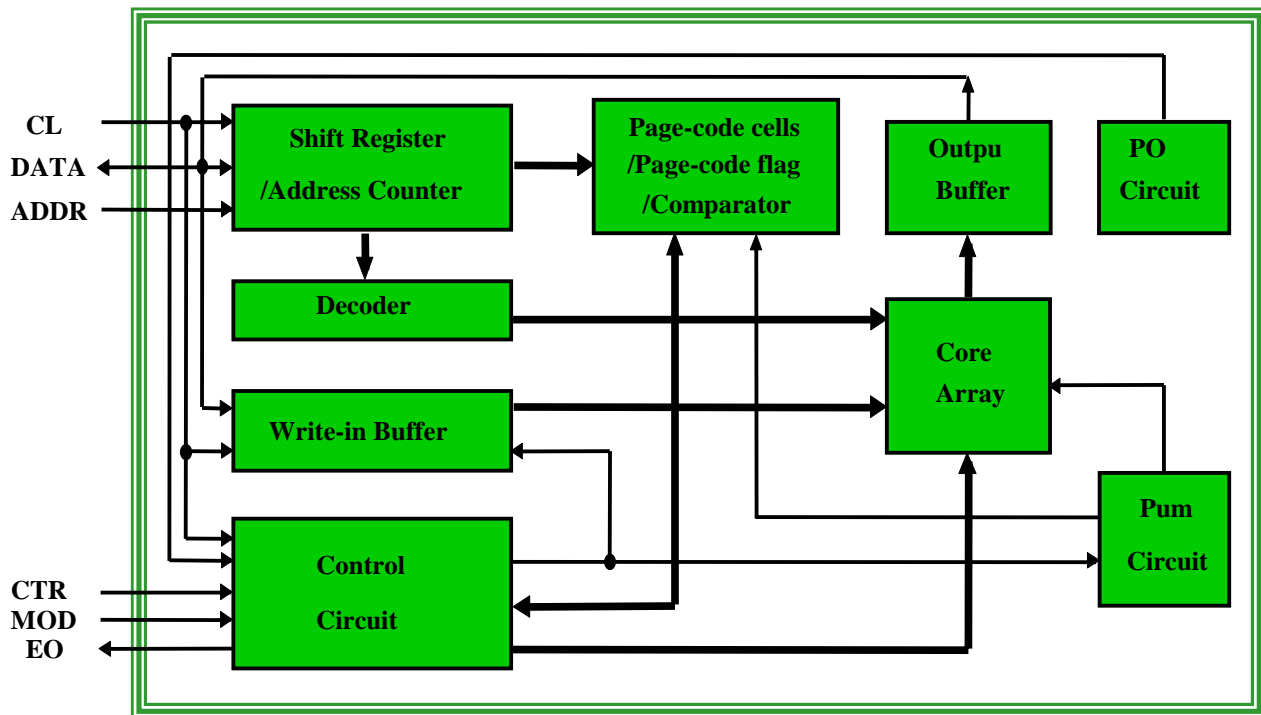

# Electrical Characteristics

## 3.1 W55Fxx Absolute Maximum Ratings

Parameter	Symbol	Condition	Rated Value	Unit
Operating Temp.	TOPR	-	0 to +70	°C
Storage Temp.	TSTG	-	-65 to +150	°C
Power Supply	VDD–VSS	-	-0.3 to +7.0	V
Input DC Voltage	VDC	All pins	-0.5 to VDD +1.0	V
Transient Voltage (< 20 nS)	VTRAN	All pins	-1.0 to VDD +1.0	V

Note: Exposure to conditions beyond those listed under Absolute Maximum Ratings may adversely affect the life and reliability of the device.

## 3.2 W55Fxx DC Characteristics

(VDD = 4.5V, VSS = 0V, TA = 25° C)

Parameter	Symbol	Condition	Limits			Unit	
			MIN.	TYP.	MAX.		
Operating voltage	VDD	-	2.4 (Note)	4.5	5.5	V	
Standby current	ISB	All inputs = GND DATA & EOP open	-	2	4	μA	
Operating current	IOP	In read mode DATA & EOP open FOSC = 1 MHz	-	5	10	mA	
Input voltage	High	All input pins	2.0		VDD	V	
	Low		VIL	-0.3	-	0.8	V
Output current	Sink	IOL	VOL = 0.5V	2.5	5	-	mA
	Drive	IOH	VOH = 4.0V	-2.5	-5	-	mA
Input leakage current of CTRL, MODE	ILI1	VIN = 4.5V	-	-	4.5	μA	
Input leakage current of DATA	ILI2	VIN = 0V	-	-	-4.5	μA	

### 3.3 W55Fxx AC Characteristics

(VDD = 4.5V, VSS = 0V, TA = 25° C)

Parameter	Symbol	Conditions	MIN.	TYP.	MAX.	Unit
MODE pulse width	TMP	-	1	-	-	μS
CTRL pulse width	TWP	Page coding mode	400	-	700	μS
Clock frequency of ADDR	FADDR	-	-	-	1	MHz
Clock frequency of CLK	FCLK	-	-	-	1	MHz
Clock frequency of CTRL	FCTRL	-	-	-	1	MHz
Interval between ADDR end & CLK begin	TI	Read/Write mode	1	-	-	μS
Interval between CLK & CTRL	TGCC	Write mode	1	-	-	μS
Interval between ADDR & CTRL	TGCA	Page coding mode	1	-	-	μS
Interval between addressing end & block-erase begin	TAE	Block erase mode	1	-	-	μS
Interval between MODE rising edge & CTRL clock begin	TMB	Mode selection	500	-	-	nS
Interval between CTRL clock end & MODE falling edge	TME	Mode selection	500	-	-	nS
Interval between MODE falling edge & another pin active	TGM	-	1	-	-	μS
Data access time	TRA	Read mode	-	-	500	nS
Data set up time	TWS	Write mode	250	-	-	nS
	TAS	-	250	-	-	nS
Data hold time	TRH	Read mode	0	-	-	nS
	TWH	Write mode	10	-	-	nS
	TAH	-	10	-	-	nS
Programming duration	TPR	Write mode	400	-	-	μS
Whole-chip-erase time	TWE	Whole-chip-erase mode	45	-	50	mS
Block-erase time	TBE	Block-erase mode	40	-	45	mS



# Timing Waveform

## 4.1 W55Fxx Timing Waveform

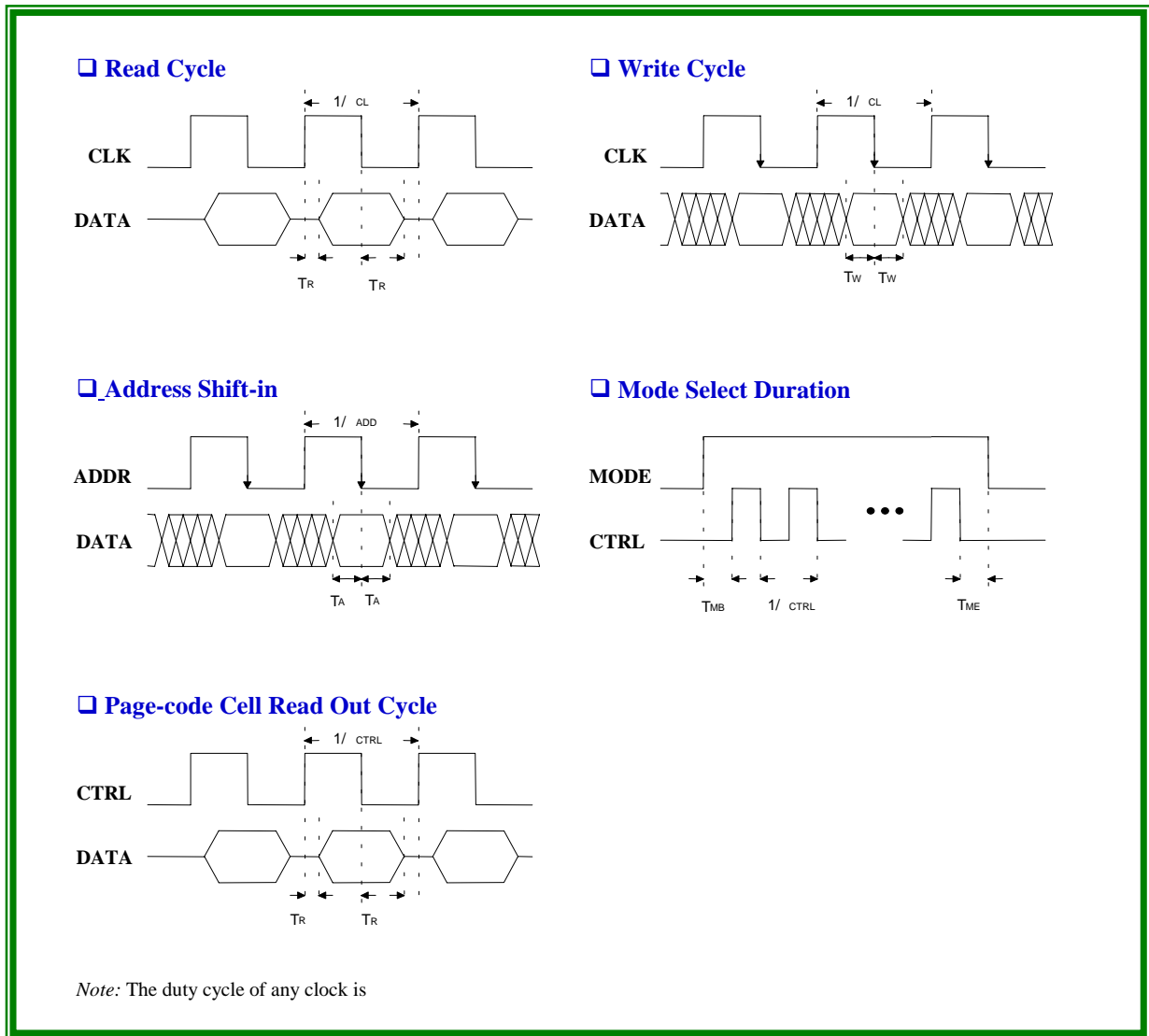



## Applications

---

### 5.1 W55Fxx Applications

□ **Winbond e-mail Reminder & Downloader application:**

**System Solution** ➤ **W55FC200+W55Fxx+W58300**

➤ **e-mail Reminder:**

In-coming e-mail Indication & Reminder (W55FC200).  
Upgradeable "Greeting words" or "Music" from web site.

➤ **Contents Downloader:**

Web site contents "Plug-&-Download" to Flash memory Card (W55Fxx).  
Flash memory contents "Plug-&-Play" by *PowerSpeech* (W58300), *ViewTalk* (W536xxxx)

□ **Winbond Voice Mail Loader:**

**System Solution** ➤ **W55FC200+W55F20+W51300**

➤ **Voice Mail Uploader:**

Message recording by "VoiceRecorder (W51300)", upload to PC & save as an e-mail file by "Uploader (W55FC200)".  
Voice message sending by e-mail.

➤ **Voice Mail Downloader:**

Message download from PC by "Downloader (W55FC200)", message play back by "VoicePlayer (W51300)".  
LED flashing indication for voice playing

## 5.2 W55Fxx Application Circuits

### W55Fxx Application Circuits (for reference only)

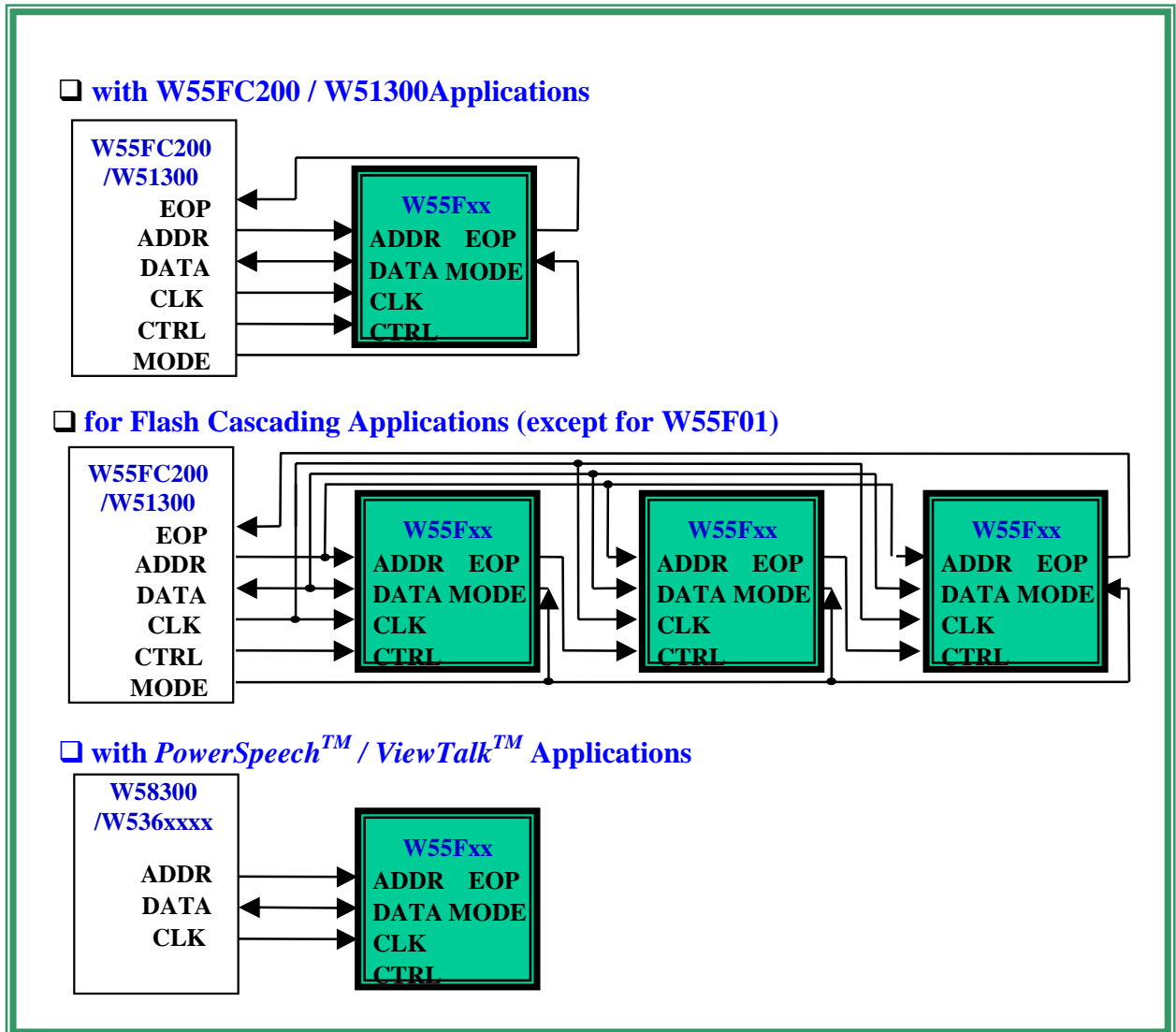



#### Headquarters

No. 4, Creation Rd. III,  
Science-Based Industrial Park,  
Hsinchu, Taiwan  
TEL: 886-3-5770066

FAX: 886-3-5792697

<http://www.winbond.com.tw/>

Voice & Fax-on-demand: 886-2-27197006

#### Taipei Office

11F, No. 115, Sec. 3, Min-Sheng East Rd.,  
Taipei, Taiwan

TEL: 886-2-27190505

FAX: 886-2-27197502

#### Winbond Electronics (H.K.) Ltd.

Rm. 803, World Trade Square, Tower II,  
123 Hoi Bun Rd., Kwun Tong,  
Kowloon, Hong Kong

TEL: 852-27513100

FAX: 852-27552064

#### Winbond Electronics North America Corp.

Winbond Memory Lab.

Winbond Microelectronics Corp.

Winbond Systems Lab.

2727 N. First Street, San Jose,

CA 95134, U.S.A.

TEL: 408-9436666

FAX: 408-5441798

---

Note: All data and specifications are subject to change without notice.