

**TV VERTICAL DEFLECTION OUTPUT CIRCUIT**

The functions incorporated are :

- POWER AMPLIFIER
- FLYBACK GENERATOR
- REFERENCE VOLTAGE
- THERMAL PROTECTION

**DESCRIPTION**

The TDA8170 is a monolithic integrated circuit in HEPTAWATT™ package. It is a high efficiency power booster for direct driving of vertical windings of TV yokes. It is intended for use in Colour and B & W television receivers as well as in monitors and displays.

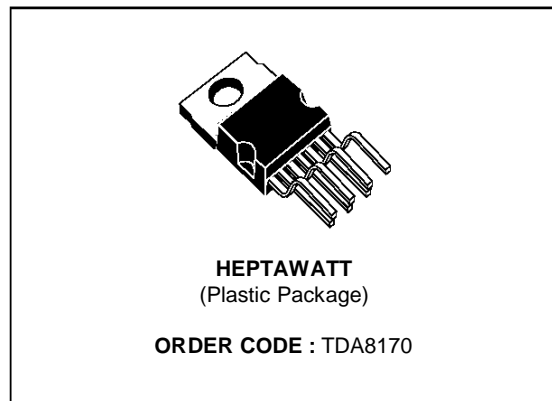

**PIN CONNECTIONS**

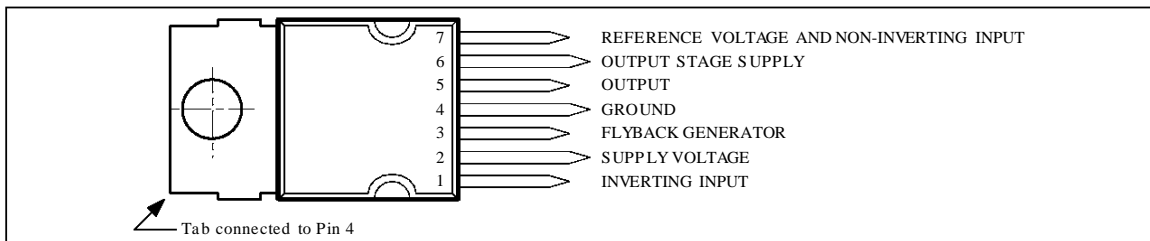

**BLOCK DIAGRAM**

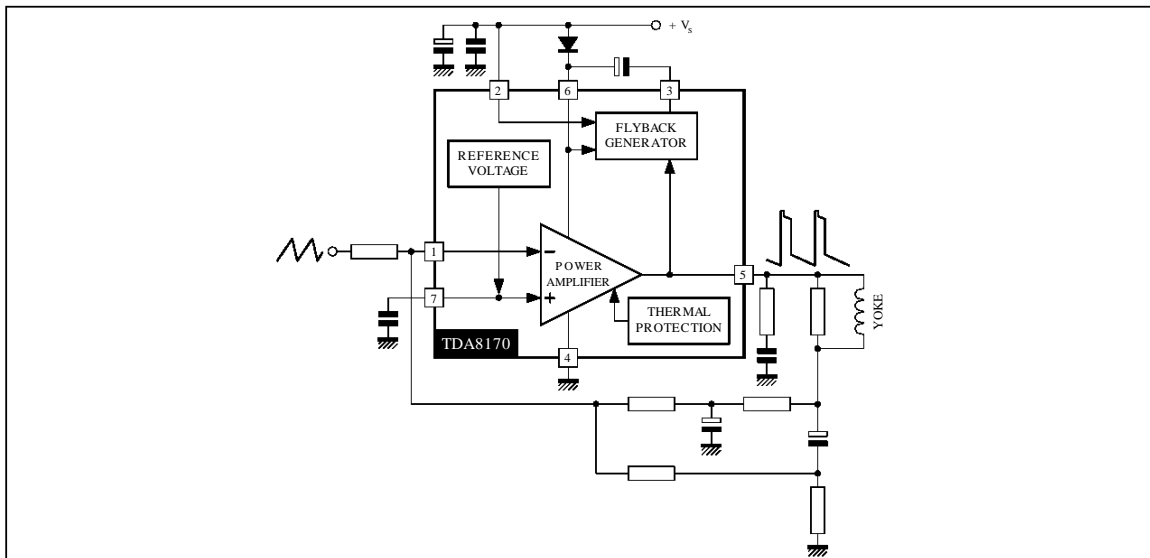

SCHEMATIC DIAGRAM

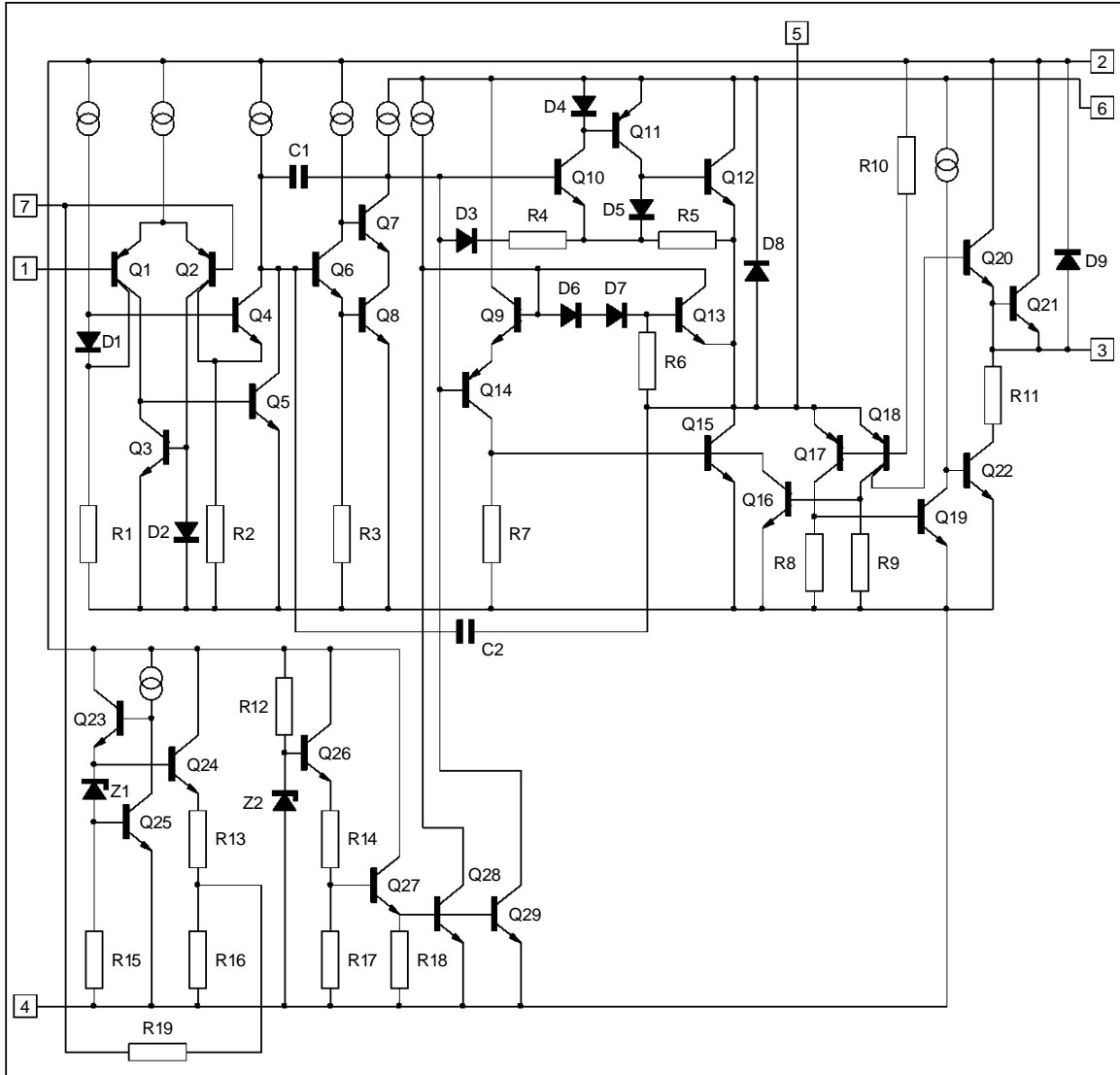

8170-03.EPS

## ABSOLUTE MAXIMUM RATINGS

Symbol	Parameter	Value	Unit
$V_S$	Supply Voltage (pin 2)	35	V
$V_5, V_6$	Flyback Peak Voltage	60	V
$V_3$	Voltage at Pin 3	+ $V_S$	
$V_1, V_7$	Amplifier Input Voltage	+ $V_S$ - 0.5	V
$I_o$	Output Peak Current (non repetitive, $t = 2$ msec)	2.5	A
$I_o$	Output Peak Current at $f = 50$ or $60$ Hz, $t \leq 10$ $\mu$ sec	3	A
$I_o$	Output Peak Current at $f = 50$ or $60$ Hz, $t > 10$ $\mu$ sec	2	A
$I_3$	Pin 3 DC Current at $V_5 < V_2$	100	mA
$I_3$	Pin 3 Peak to Peak Flyback Current at $f = 50$ or $60$ Hz, $t_{fly} \leq 1.5$ msec	3	A
$P_{tot}$	Total Power Dissipation at $T_{case} = 90$ °C	20	W
$T_{stg}, T_j$	Storage and Junction Temperature	- 40 to 150	°C

8170-01.TBL

## THERMAL DATA

Symbol	Parameter	Value	Unit
$R_{th\ j-case}$	Thermal Resistance Junction-case Max.	3	°C/W

8170-02.TBL

## ELECTRICAL CHARACTERISTICS

(refer to the test circuits,  $V_S = 35V$ ,  $T_{amb} = 25^\circ C$  unless otherwise specified)

Symbol	Parameter	Test Conditions	Min.	Typ.	Max.	Unit	Fig.
$I_2$	Pin 2 Quiescent Current	$I_3 = 0, I_5 = 0$		8	16	mA	1a
$I_6$	Pin 6 Quiescent Current	$I_3 = 0, I_5 = 0$		16	36	mA	1a
$I_1$	Amplifier Input Bias Current	$V_1 = 1$ V		- 0.1	- 1	$\mu$ A	1a
$V_7$	Reference Voltage			2.2		V	1a
$\frac{\Delta V_7}{\Delta V_S}$	Reference Voltage Drift versus Supply Voltage	$V_S = 15$ to $30$ V		1	2	mV/V	1a
$V_{3L}$	Pin 3 Saturation Voltage to GND	$I_3 = 20$ mA		1		V	1c
$V_5$	Quiescent Output Voltage	$V_S = 35$ V, $R_a = 39$ k $\Omega$		18		V	1d
		$V_S = 15$ V, $R_a = 13$ k $\Omega$		7.5		V	1d
$V_{5L}$	Output Saturation Voltage to GND	$I_5 = 1.2$ A		1	1.4	V	1c
		$I_5 = 0.7$ A		0.7	1	V	1c
$V_{5H}$	Output Saturation Voltage to Supply	- $I_5 = 1.2$ A		1.6	2.2	V	1b
		- $I_5 = 0.7$ A		1.3	1.8	V	1b
$T_j$	Junction Temperature for Thermal Shut Down			140		°C	

8170-03.TBL

Figure 1a : Measurement of  $I_1$ ,  $I_2$ ,  $I_6$ ,  $V_7$ ,  $\Delta V_7/\Delta V_S$

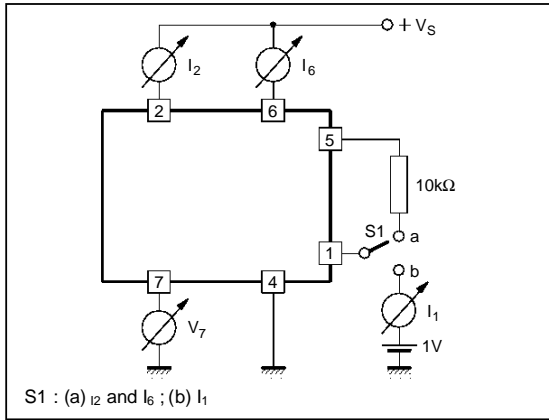

8170-04.EPS

Figure 1b : Measurement of  $V_{5H}$

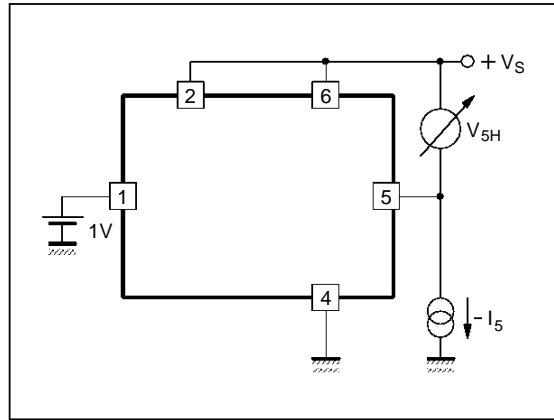

8170-05.EPS

Figure 1c : Measurement of  $V_{3L}$ ,  $V_{5L}$

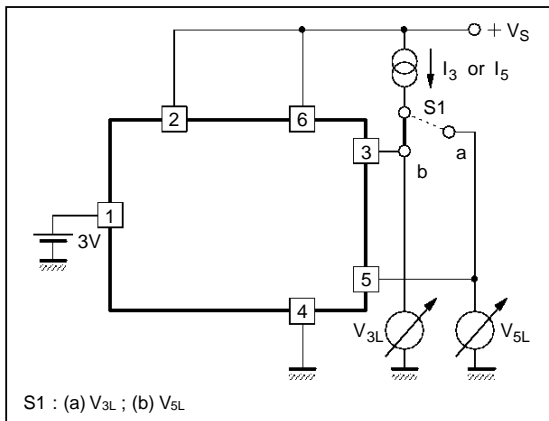

8170-06.EPS

Figure 1d : Measurement of  $V_5$

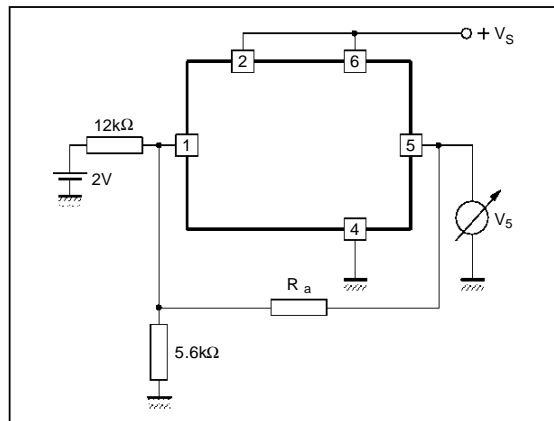

8170-07.EPS

Figure 2 : AC Test Circuit

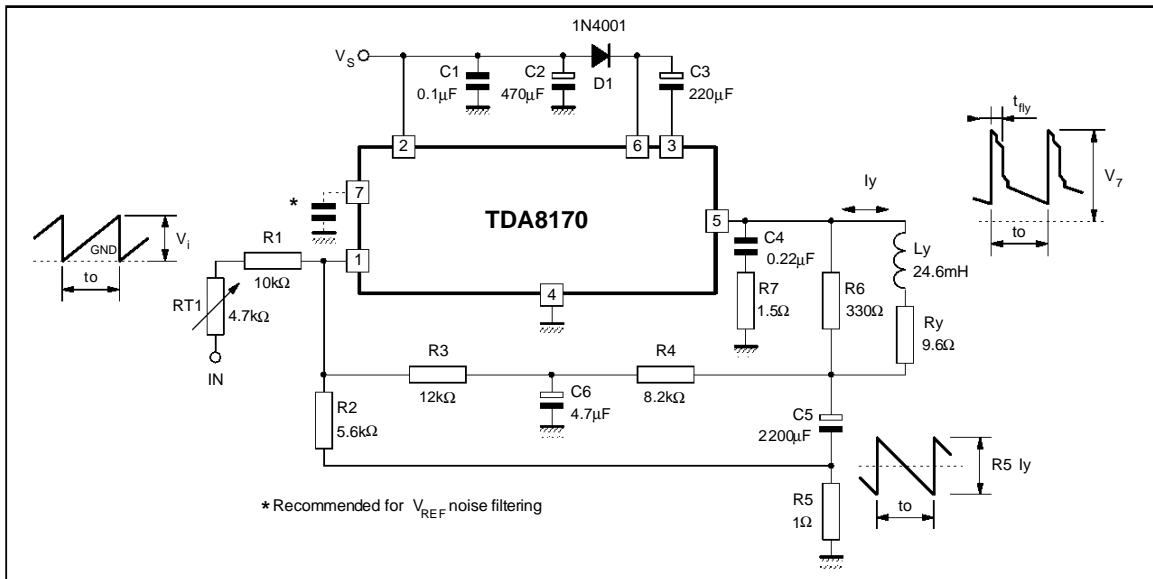

8170-08.EPS

**Figure 3 :** PC Board and Component layout of the Circuit of fig. 2(1 : 1 scale)

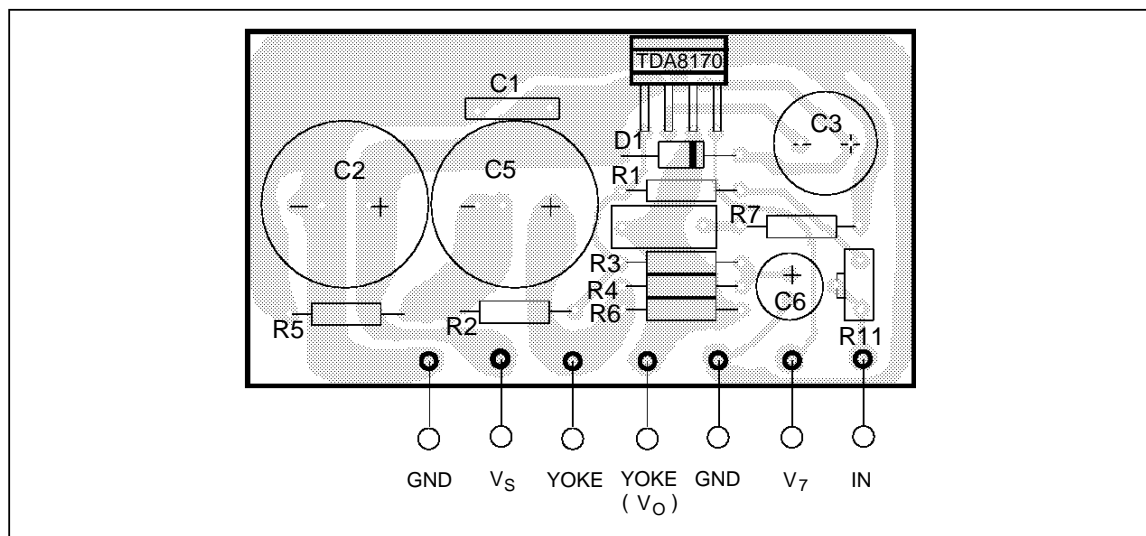

8170-09.EPS

#### COMPONENTS LIST FOR TYPICAL APPLICATIONS

Component	110 ° TVC 5.9 Ω/10 mH 1.95 App	110 ° TVC 9.6 Ω/24.6 mH 1.2 App	90 ° TVC 15 Ω/30 mH 0.82 App	Unit
RT1	10	4.7	10	kΩ
R1	12	10	12	kΩ
R2	10	5.6	5.6	kΩ
R3	27	12	18	kΩ
R4	12	8.2	5.6	kΩ
R5	0.82	1	1	Ω
R6	270	330	330	Ω
R7	1.5	1.5	1.5	Ω
D1	1N 4001	1N 4001	1N 4001	–
C1	0.1	0.1	0.1	μF
C2 el.	1000/25 V	470/25 V	470/25 V	μF
C3 el.	220/25 V	220/25 V	220/25 V	μF
C4	0.22	0.22	0.22	μF
C5 el.	200/25 V	2200/25 V	1000/16 V	μF
C6 el.	4.7/16 V	4.7/16 V	10/16 V	μF

8170-04.TBL

**TYPICAL PERFORMANCES**

Parameter	110 ° TVC 5.9 Ω/10 mH	110 ° TVC 9.6 Ω/27 mH	90 ° TVC 15 Ω/30 mH	Unit
V <sub>s</sub> - Supply Voltage	24	22.5	25	V
I <sub>s</sub> - Current	280	175	125	mA
t <sub>fly</sub> - Flyback Time	0.6	1	0.7	ms
P <sub>tot</sub> - Power Dissip.	4.2	2.5	2.05	W
R <sub>th o-a</sub> - Heatsink	7	13	16	°C/W
T <sub>amb</sub>	60	60	60	°C
T <sub>jmax</sub>	110	110	110	°C
T <sub>o</sub>	20	20	20	ms
V <sub>l</sub>	2.5	2.5	2.5	V <sub>pp</sub>
V <sub>7</sub>	2.5	2.5	2.5	V <sub>p</sub>

8170-05.TBL

**MOUNTING INSTRUCTIONS**

The power dissipated in the circuit must be removed by adding an external heatsink. Thanks to the HEPTAWATT™ package attaching the heatsink is very simple, a screw a compression

spring (clip) being sufficient. Between the heatsink and the package it is better to insert a layer of silicon grease, to optimize the thermal contact ; no electrical isolation is needed between the two surfaces.

**Figure 4 : Mounting Examples**

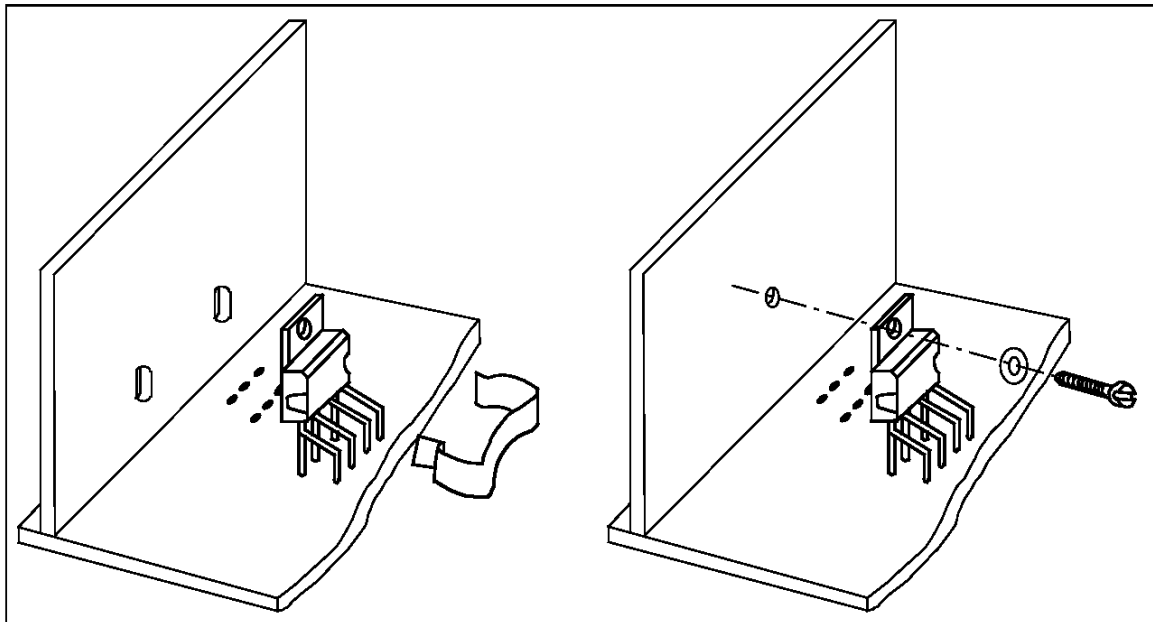

8170-10.EPS

## PACKAGE MECHANICAL DATA : 7 PINS - PLASTIC HEPTAWATT

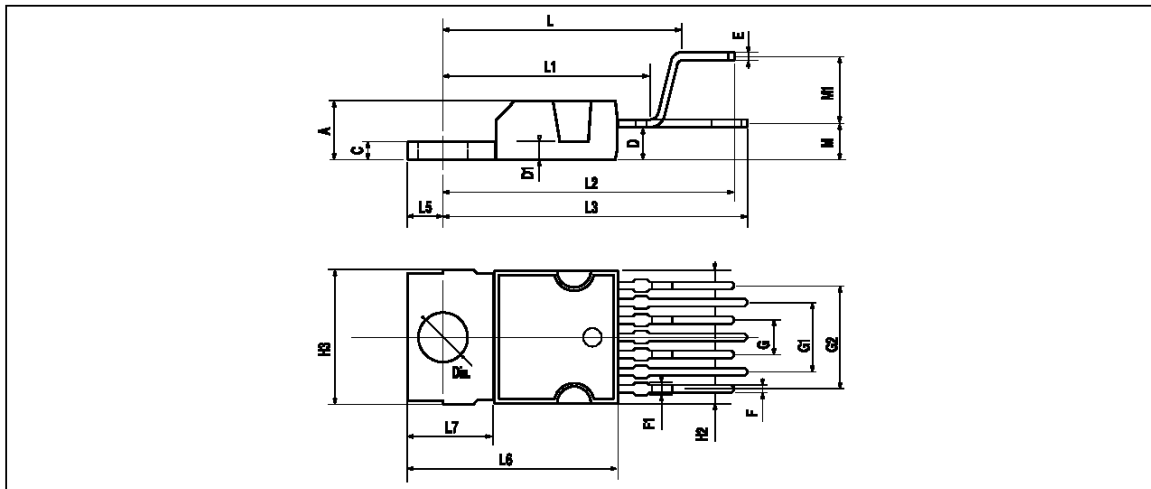

Dimensions	Millimeters			Inches		
	Min.	Typ.	Max.	Min.	Typ.	Max.
A			4.8			0.189
C			1.37			0.054
D	2.4		2.8	0.094		0.110
D1	1.2		1.35	0.047		0.053
E	0.35		0.55	0.014		0.022
F	0.6		0.8	0.024		0.031
F1			0.9			0.035
G	2.41	2.54	2.67	0.095	0.100	0.105
G1	4.91	5.08	5.21	0.193	0.200	0.205
G2	7.49	7.62	7.8	0.295	0.300	0.307
H2			10.4			0.409
H3	10.05		10.4	0.396		0.409
L		16.97			0.668	
L1		14.92			0.587	
L2		21.54			0.848	
L3		22.62			0.891	
L5	2.6		3	0.102		0.118
L6	15.1		15.8	0.594		0.622
L7	6		6.6	0.236		0.260
M		2.8			0.110	
M1		5.08			0.200	
Dia.	3.65		3.85	0.144		0.152

Information furnished is believed to be accurate and reliable. However, SGS-THOMSON Microelectronics assumes no responsibility for the consequences of use of such information nor for any infringement of patents or other rights of third parties which may result from its use. No licence is granted by implication or otherwise under any patent or patent rights of SGS-THOMSON Microelectronics. Specifications mentioned in this publication are subject to change without notice. This publication supersedes and replaces all information previously supplied. SGS-THOMSON Microelectronics products are not authorized for use as critical components in life support devices or systems without express written approval of SGS-THOMSON Microelectronics.

© 1996 SGS-THOMSON Microelectronics - All Rights Reserved

Purchase of  $\mu$ C Components of SGS-THOMSON Microelectronics, conveys a license under the Philips  $\mu$ C Patent. Rights to use these components in a  $\mu$ C system, is granted provided that the system conforms to the  $\mu$ C Standard Specifications as defined by Philips.

SGS-THOMSON Microelectronics GROUP OF COMPANIES

Australia - Brazil - Canada - China - France - Germany - Hong Kong - Italy - Japan - Korea - Malaysia - Malta - Morocco  
The Netherlands - Singapore - Spain - Sweden - Switzerland - Taiwan - Thailand - United Kingdom - U.S.A.