

Features

- Internal control latches and address decoder
- Short set-up and hold times
- Wide operating voltage: 4.5V to 13.2V
- 12Vpp analog signal capability
- R_{ON} 65 Ω max. @ $V_{DD}=12V$, 25°C
- $\Delta R_{ON} \leq 10\Omega$ @ $V_{DD}=12V$, 25°C
- Full CMOS switch for low distortion
- Minimum feedthrough and crosstalk
- Separate analog and digital reference supplies
- Low power consumption ISO-CMOS technology

Applications

- Key systems
- PBX systems
- Mobile radio
- Test equipment/instrumentation
- Analog/digital multiplexers
- Audio/Video switching

Ordering Information

MT8816AC	40 Pin Ceramic DIP
MT8816AE	40 Pin Plastic DIP
MT8816AP	44 Pin PLCC
-40° to 85°C	

Description

The Mitel MT8816 is fabricated in MITEL's ISO-CMOS technology providing low power dissipation and high reliability. The device contains a 8 x 16 array of crosspoint switches along with a 7 to 128 line decoder and latch circuits. Any one of the 128 switches can be addressed by selecting the appropriate seven address bits. The selected switch can be turned on or off by applying a logical one or zero to the DATA input. V_{SS} is the ground reference of the digital inputs. The range of the analog signal is from V_{DD} to V_{EE} . Chip Select (CS) allows the crosspoint array to be cascaded for matrix expansion.

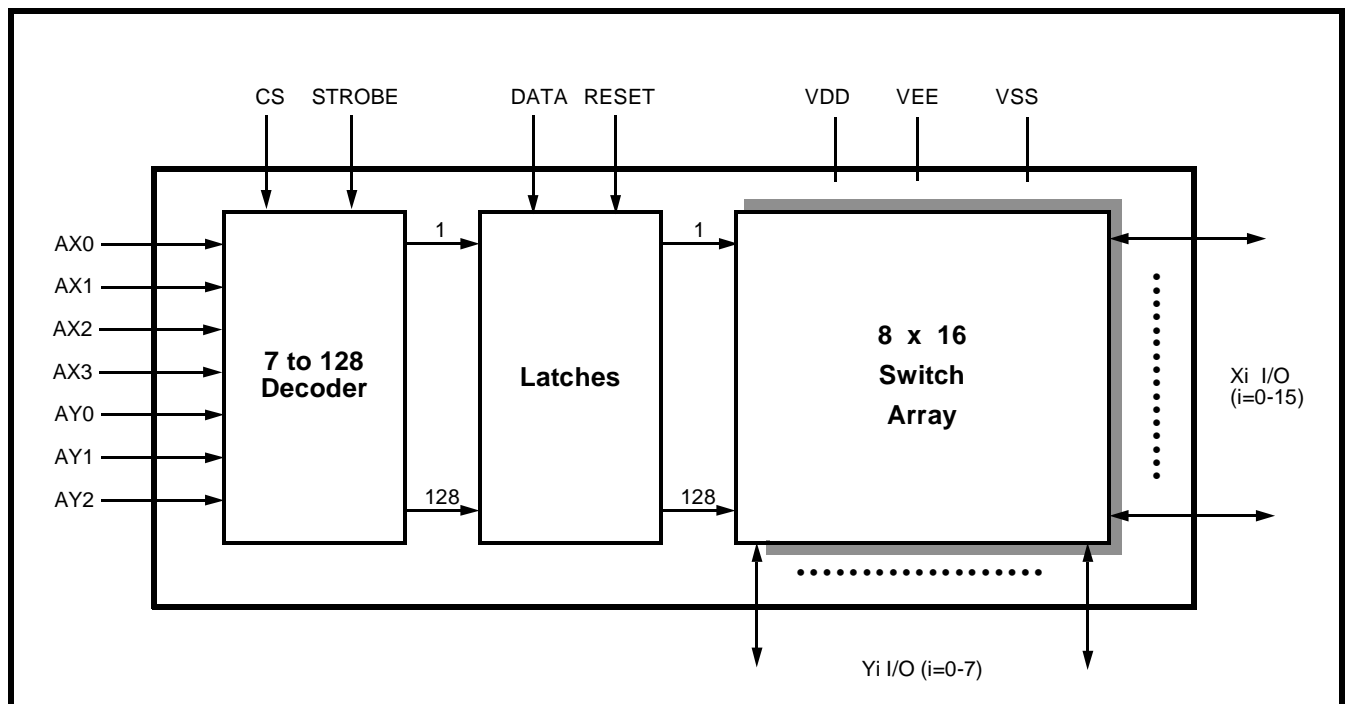

Figure 1 - Functional Block Diagram

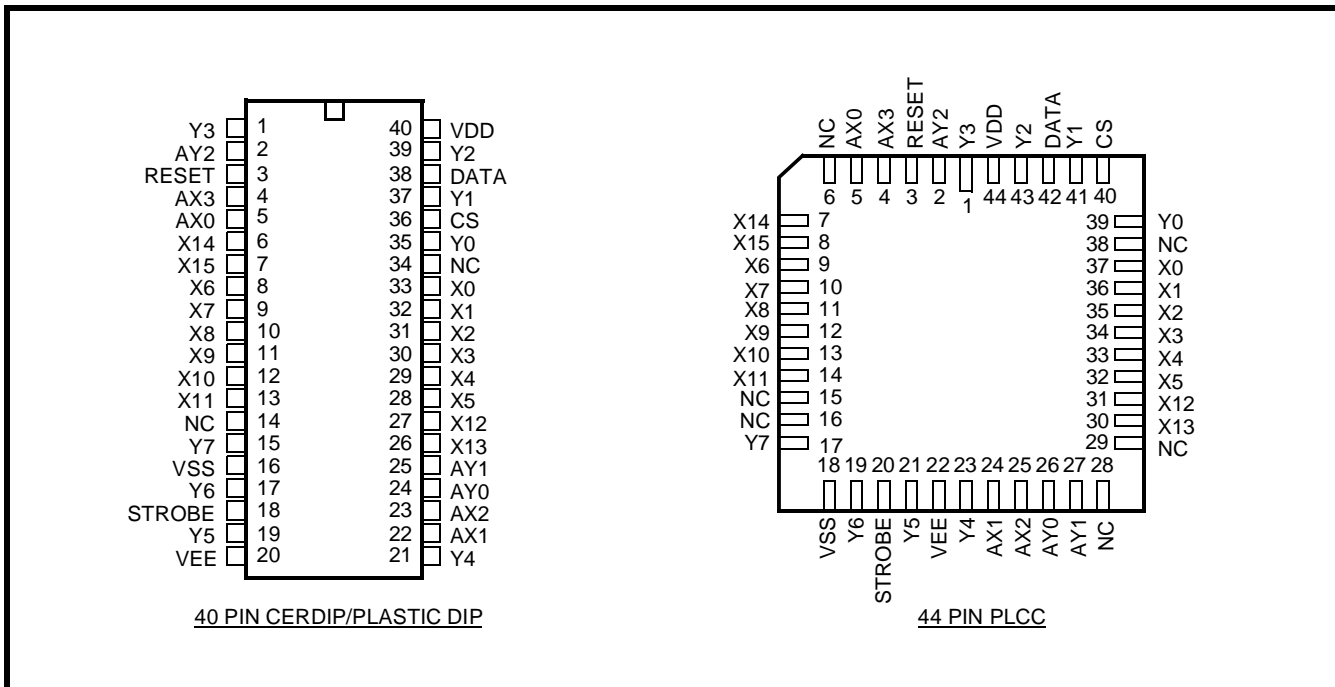

Figure 2 - Pin Connections

Pin Description

Pin #*	Name	Description
1	Y3	Y3 Analog (Input/Output): this is connected to the Y3 column of the switch array.
2	AY2	Y2 Address Line (Input).
3	RESET	Master RESET (Input): this is used to turn off all switches regardless of the condition of CS. Active High.
4,5	AX3,AX0	X3 and X0 Address Lines (Inputs).
6,7	X14, X15	X14 and X15 Analog (Inputs/Outputs): these are connected to the X14 and X15 rows of the switch array.
8-13	X6-X11	X6-X11 Analog (Inputs/Outputs): these are connected to the X6-X11 rows of the switch array.
14	NC	No Connection
15	Y7	Y7 Analog (Input/Output): this is connected to the Y7 column of the switch array.
16	V _{SS}	Digital Ground Reference.
17	Y6	Y6 Analog (Input/Output): this is connected to the Y6 column of the switch array.
18	STROBE	STROBE (Input): enables function selected by address and data. Address must be stable before STROBE goes high and DATA must be stable on the falling edge of the STROBE. Active High.
19	Y5	Y5 Analog (Input/Output): this is connected to the Y5 column of the switch array.
20	V _{EE}	Negative Power Supply.
21	Y4	Y4 Analog (Input/Output): this is connected to the Y4 column of the switch array.
22, 23	AX1,AX2	X1 and X2 Address Lines (Inputs).
24, 25	AY0,AY1	Y0 and Y1 Address Lines (Inputs).

* Plastic DIP and CERDIP only

Pin Description (continued)

Pin #*	Name	Description
26, 27	X13, X12	X13 and X12 Analog (Inputs/Outputs): these are connected to the X13 and X12 rows of the switch array.
28 - 33	X5-X0	X5-X0 Analog (Inputs/Outputs): these are connected to the X5-X0 rows of the switch array.
34	NC	No Connection.
35	Y0	Y0 Analog (Input/Output): this is connected to the Y0 column of the switch array.
36	CS	Chip Select (Input): this is used to select the device. Active High.
37	Y1	Y1 Analog (Input/Output): this is connected to the Y1 column of the switch array.
38	DATA	DATA (Input): a logic high input will turn on the selected switch and a logic low will turn off the selected switch. Active High.
39	Y2	Y2 Analog (Input/Output): this is connected to the Y2 column of the switch array.
40	V _{DD}	Positive Power Supply.

* Plastic DIP and CERDIP only

Functional Description

The MT8816 is an analog switch matrix with an array size of 8 x 16. The switch array is arranged such that there are 8 columns by 16 rows. The columns are referred to as the Y inputs/outputs and the rows are the X inputs/outputs. The crosspoint analog switch array will interconnect any X I/O with any Y I/O when turned on and provide a high degree of isolation when turned off. The control memory consists of a 128 bit write only RAM in which the bits are selected by the address inputs (AY0-AY2, AX0-AX3). Data is presented to the memory on the DATA input. Data is asynchronously written into memory whenever both the CS (Chip Select) and STROBE inputs are high and are latched on the falling edge of STROBE. A logical "1" written into a memory cell turns the corresponding crosspoint switch on and a logical "0" turns the crosspoint off. Only the crosspoint switches corresponding to the addressed memory location are altered when data is written into memory. The remaining switches retain their previous states. Any combination of X and Y inputs/outputs can be interconnected by establishing appropriate patterns in the control memory. A logical "1" on the RESET input will asynchronously return all memory locations to logical "0" turning off all crosspoint switches regardless of whether CS is high or low. Two voltage reference pins (V_{SS} and V_{EE}) are provided for the MT8816 to enable switching of negative analog signals. The range for digital signals is from V_{DD} to V_{SS} while the range for analog signals is from V_{DD} to V_{EE}. V_{SS} and V_{EE} pins can be tied together if a single voltage reference is needed.

Address Decode

The seven address inputs along with the STROBE and CS (Chip Select) are logically ANDed to form an enable signal for the resettable transparent latches. The DATA input is buffered and is used as the input to all latches. To write to a location, RESET must be low and CS must go high while the address and data are set up. Then the STROBE input is set high and then low causing the data to be latched. The data can be changed while STROBE is high, however, the corresponding switch will turn on and off in accordance with the DATA input. DATA must be stable on the falling edge of STROBE in order for correct data to be written to the latch.

Absolute Maximum Ratings* - Voltages are with respect to V_{EE} unless otherwise stated.

	Parameter	Symbol	Min	Max	Units
1	Supply Voltage	V_{DD} V_{SS}	-0.3 -0.3	16.0 $V_{DD}+0.3$	V V
2	Analog Input Voltage	V_{INA}	-0.3	$V_{DD}+0.3$	V
3	Digital Input Voltage	V_{IN}	$V_{SS}-0.3$	$V_{DD}+0.3$	V
4	Current on any I/O Pin	I		±15	mA
5	Storage Temperature	T_S	-65	+150	°C
6	Package Power Dissipation	PLASTIC DIP CERDIP	P_D P_D	0.6 1.0	W W

* Exceeding these values may cause permanent damage. Functional operation under these conditions is not implied.

Recommended Operating Conditions - Voltages are with respect to V_{EE} unless otherwise stated.

	Characteristics	Sym	Min	Typ	Max	Units	Test Conditions
1	Operating Temperature	T_O	-40	25	85	°C	
2	Supply Voltage	V_{DD} V_{SS}	4.5 V_{EE}		13.2 $V_{DD}-4.5$	V V	
3	Analog Input Voltage	V_{INA}	V_{EE}		V_{DD}	V	
4	Digital Input Voltage	V_{IN}	V_{SS}		V_{DD}	V	

DC Electrical Characteristics† - Voltages are with respect to $V_{EE}=V_{SS}=0V$, $V_{DD}=12V$ unless otherwise stated.

	Characteristics	Sym	Min	Typ†	Max	Units	Test Conditions
1	Quiescent Supply Current	I_{DD}		1	100	µA	All digital inputs at $V_{IN}=V_{SS}$ or V_{DD}
			0.4	1.5	mA	All digital inputs at $V_{IN}=2.4V + V_{SS}$; $V_{SS}=7.0V$	
			5	15	mA	All digital inputs at $V_{IN}=3.4V$	
2	Off-state Leakage Current (See G.9 in Appendix)	I_{OFF}		±1	±500	nA	$ V_{Xi} - V_{Yj} = V_{DD} - V_{EE}$ See Appendix, Fig. A.1
3	Input Logic "0" level	V_{IL}			$0.8+V_{SS}$	V	$V_{SS}=7.5V$; $V_{EE}=0V$
4	Input Logic "1" level	V_{IH}	$2.0+V_{SS}$			V	$V_{SS}=6.5V$; $V_{EE}=0V$
5	Input Logic "1" level	V_{IH}	3.3			V	
6	Input Leakage (digital pins)	I_{LEAK}		0.1	10	µA	All digital inputs at $V_{IN} = V_{SS}$ or V_{DD}

† DC Electrical Characteristics are over recommended temperature range.

‡ Typical figures are at 25°C and are for design aid only; not guaranteed and not subject to production testing.

DC Electrical Characteristics- Switch Resistance - V_{DC} is the external DC offset applied at the analog I/O pins.

	Characteristics	Sym	25°C		70°C		85°C		Units	Test Conditions
			Typ	Max	Typ	Max	Typ	Max		
1	On-state Resistance $V_{DD}=12V$ $V_{DD}=10V$ $V_{DD}=5V$ (See G.1, G.2, G.3 in Appendix)	R_{ON}	45	65		75		80	Ω	$V_{SS}=V_{EE}=0V, V_{DC}=V_{DD}/2,$ $ V_{Xi}-V_{Yj} = 0.4V$ See Appendix, Fig. A.2
55			75		85		90			
120			185		215		225			
2	Difference in on-state resistance between two switches (See G.4 in Appendix)	ΔR_{ON}	5	10		10		10	Ω	$V_{DD}=12V, V_{SS}=V_{EE}=0,$ $V_{DC}=V_{DD}/2,$ $ V_{Xi}-V_{Yj} = 0.4V$ See Appendix, Fig. A.2

AC Electrical Characteristics[†] - Crosspoint Performance

Voltages are with respect to $V_{DD}=5V$, $V_{SS}=0V$, $V_{EE}=-7V$, unless otherwise stated.

	Characteristics	Sym	Min	Typ [‡]	Max	Units	Test Conditions
1	Switch I/O Capacitance	C_S		20		pF	$f=1$ MHz
2	Feedthrough Capacitance	C_F		0.2		pF	$f=1$ MHz
3	Frequency Response Channel "ON" $20\text{LOG}(V_{OUT}/V_{Xi})=-3\text{dB}$	$F_{3\text{dB}}$		45		MHz	Switch is "ON"; $V_{INA} = 2V_{pp}$ sine wave; $R_L = 1k\Omega$ See Appendix, Fig. A.3
4	Total Harmonic Distortion (See G.5, G.6 in Appendix)	THD		0.01		%	Switch is "ON"; $V_{INA} = 2V_{pp}$ sine wave $f= 1\text{kHz}$; $R_L=1k\Omega$
5	Feedthrough Channel "OFF" Feed.= $20\text{LOG}(V_{OUT}/V_{Xi})$ (See G.8 in Appendix)	FDT		-95		dB	All Switches "OFF"; $V_{INA}= 2V_{pp}$ sine wave $f= 1\text{kHz}$; $R_L= 1k\Omega$. See Appendix, Fig. A.4
6	Crosstalk between any two channels for switches X_i-Y_i and X_j-Y_j . $X_{\text{talk}}=20\text{LOG}(V_{Yj}/V_{Xi})$. (See G.7 in Appendix).	X_{talk}		-45		dB	$V_{INA}=2V_{pp}$ sine wave $f= 10\text{MHz}$; $R_L = 75\Omega$.
				-90		dB	$V_{INA}=2V_{pp}$ sine wave $f= 10\text{kHz}$; $R_L = 600\Omega$.
				-85		dB	$V_{INA}=2V_{pp}$ sine wave $f= 10\text{kHz}$; $R_L = 1k\Omega$.
				-80		dB	$V_{INA}=2V_{pp}$ sine wave $f= 1\text{kHz}$; $R_L = 10k\Omega$. Refer to Appendix, Fig. A.5 for test circuit.
7	Propagation delay through switch	t_{PS}			30	ns	$R_L=1k\Omega$; $C_L=50\text{pF}$

[†] Timing is over recommended temperature range. See Fig. 3 for control and I/O timing details.

[‡] Typical figures are at 25°C and are for design aid only; not guaranteed and not subject to production testing.

Crosstalk measurements are for Plastic DIPs only, crosstalk values for PLCC packages are approximately 5dB better.

AC Electrical Characteristics[†] - Control and I/O Timings

Voltages are with respect to $V_{DD}=5V$, $V_{SS}=0V$, $V_{EE}=-7V$, unless otherwise stated.

	Characteristics	Sym	Min	Typ [‡]	Max	Units	Test Conditions
1	Control Input crosstalk to switch (for CS, DATA, STROBE, Address)	CX_{talk}		30		mVpp	$V_{IN}=3V$ square wave; $R_{IN}=1k\Omega$, $R_L=10k\Omega$. See Appendix, Fig. A.6
2	Digital Input Capacitance	C_{DI}		10		pF	$f=1\text{MHz}$
3	Switching Frequency	F_O			20	MHz	
4	Setup Time DATA to STROBE	t_{DS}	10			ns	$R_L= 1k\Omega$, $C_L=50\text{pF}$ ^①
5	Hold Time DATA to STROBE	t_{DH}	10			ns	$R_L= 1k\Omega$, $C_L=50\text{pF}$ ^①
6	Setup Time Address to STROBE	t_{AS}	10			ns	$R_L= 1k\Omega$, $C_L=50\text{pF}$ ^①
7	Hold Time Address to STROBE	t_{AH}	10			ns	$R_L= 1k\Omega$, $C_L=50\text{pF}$ ^①
8	Setup Time CS to STROBE	t_{CSS}	10			ns	$R_L= 1k\Omega$, $C_L=50\text{pF}$ ^①
9	Hold Time CS to STROBE	t_{CSH}	10			ns	$R_L= 1k\Omega$, $C_L=50\text{pF}$ ^①
10	STROBE Pulse Width	t_{SPW}	20			ns	$R_L= 1k\Omega$, $C_L=50\text{pF}$ ^①
11	RESET Pulse Width	t_{RPW}	40			ns	$R_L= 1k\Omega$, $C_L=50\text{pF}$ ^①
12	STROBE to Switch Status Delay	t_S		40	100	ns	$R_L= 1k\Omega$, $C_L=50\text{pF}$ ^①
13	DATA to Switch Status Delay	t_D		50	100	ns	$R_L= 1k\Omega$, $C_L=50\text{pF}$ ^①
14	RESET to Switch Status Delay	t_R		35	100	ns	$R_L= 1k\Omega$, $C_L=50\text{pF}$ ^①

[†] Timing is over recommended temperature range. See Fig. 3 for control and I/O timing details.

Digital Input rise time (t_r) and fall time (t_f) = 5ns.

[‡] Typical figures are at 25°C and are for design aid only; not guaranteed and not subject to production testing.

① Refer to Appendix, Fig. A.7 for test circuit.

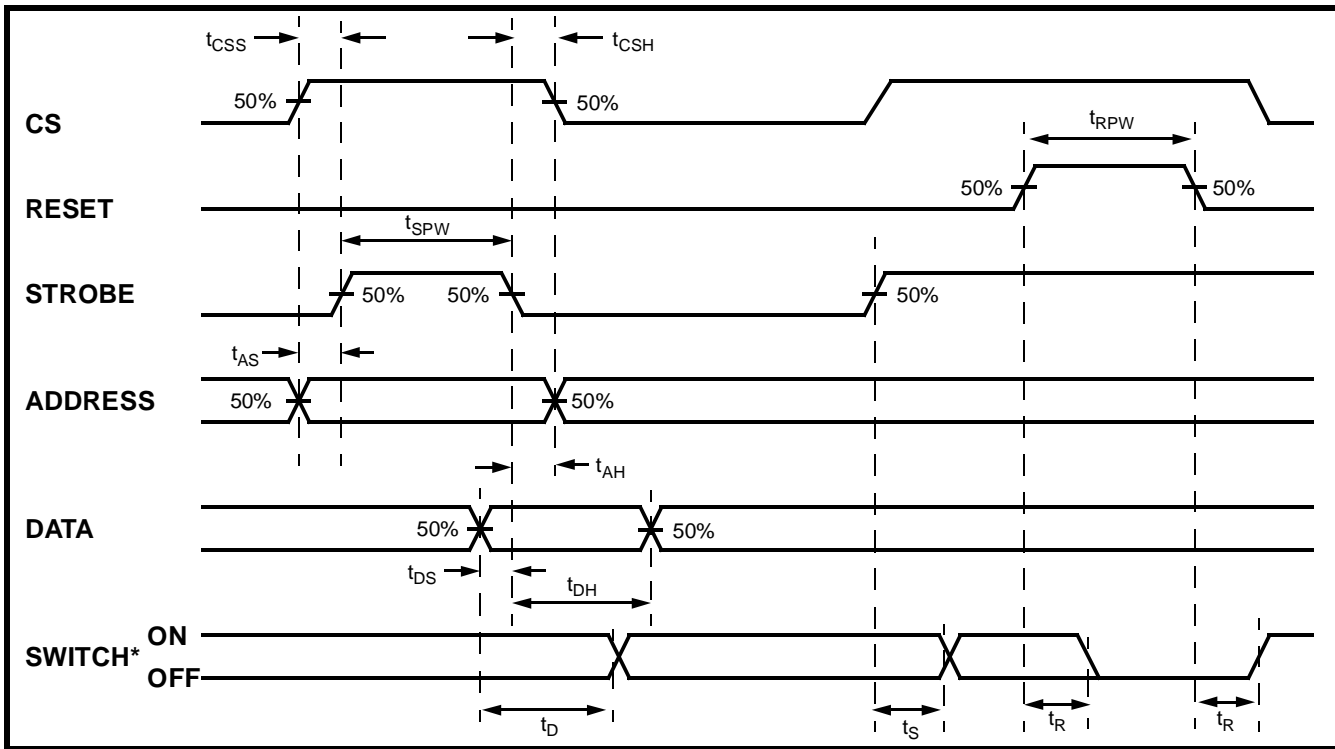

Figure 3 - Control Memory Timing Diagram

* See Appendix, Fig. A.7 for switching waveform

AX0	AX1	AX2	AX3	AY0	AY1	AY2	Connection*
0	0	0	0	0	0	0	X0-Y0
1	0	0	0	0	0	0	X1-Y0
0	1	0	0	0	0	0	X2-Y0
1	1	0	0	0	0	0	X3-Y0
0	0	1	0	0	0	0	X4-Y0
1	0	1	0	0	0	0	X5-Y0
0	1	1	0	0	0	0	X12-Y0
1	1	1	0	0	0	0	X13-Y0
0	0	0	1	0	0	0	X6-Y0
1	0	0	1	0	0	0	X7-Y0
0	1	0	1	0	0	0	X8-Y0
1	1	0	1	0	0	0	X9-Y0
0	0	1	1	0	0	0	X10-Y0
1	0	1	1	0	0	0	X11-Y0
0	1	1	1	0	0	0	X14-Y0
1	1	1	1	0	0	0	X15-Y0
0	0	0	0	1	0	0	X0-Y1
1	1	1	1	1	0	0	X15-Y1
0	0	0	0	0	1	0	X0-Y2
1	1	1	1	0	1	0	X15-Y2
0	0	0	0	1	1	0	X0-Y3
1	1	1	1	1	1	0	X15-Y3
0	0	0	0	0	0	1	X0-Y4
1	1	1	1	0	0	1	X15-Y4
0	0	0	0	1	0	1	X0-Y5
1	1	1	1	1	0	1	X15-Y5
0	0	0	0	0	1	1	X0-Y6
1	1	1	1	0	1	1	X15-Y6
0	0	0	0	1	1	1	X0-Y7
1	1	1	1	1	1	1	X15-Y7

Table 1. Address Decode Truth Table

* Switch connections are not in ascending order