

ADC08831/ADC08832 8-Bit Serial I/O CMOS A/D Converters with Multiplexer and Sample/Hold Function

General Description

The ADC08831/ADC08832 are 8-bit successive approximation Analog to Digital converters with 3-wire serial interfaces and a configurable input multiplexer for 2 channels. The serial I/O will interface to COPS™ family of micro-controllers, PLD's, microprocessors, DSP's, or shift registers. The serial I/O is configured to comply with the NSC MICROWIRE™ serial data exchange standard.

To minimize total power consumption, the ADC08831/ADC08832 automatically go into low power mode whenever they are not performing conversions.

A track/hold function allows the analog voltage at the positive input to vary during the actual A/D conversion.

The analog inputs can be configured to operate in various combinations of single-ended, differential, or pseudo-differential modes. The voltage reference input can be adjusted to allow encoding of small analog voltage spans to the full 8-bits of resolution.

Applications

- Digitizing sensors and waveforms
- Process control monitoring

- Remote sensing in noisy environments
- Instrumentation
- Embedded Systems

Features

- 3-wire serial digital data link requires few I/O pins
- Analog input track/hold function
- 2-channel input multiplexer option with address logic
- Analog input voltage range from GND to V_{CC}
- No zero or full scale adjustment required
- TTL/CMOS input/output compatible
- Superior pin compatible replacement for ADC0831/2

Key Specifications

- Resolution: 8 bits
- Conversion time ($f_C = 2$ MHz): 4 μ s (max)
- Power dissipation: 8.5mW (typ)
- Low power mode: 3.0mW (typ)
- Single supply: 5V_{DC}
- Total unadjusted error: ± 1 LSB
- No missing codes over temperature

Typical Application

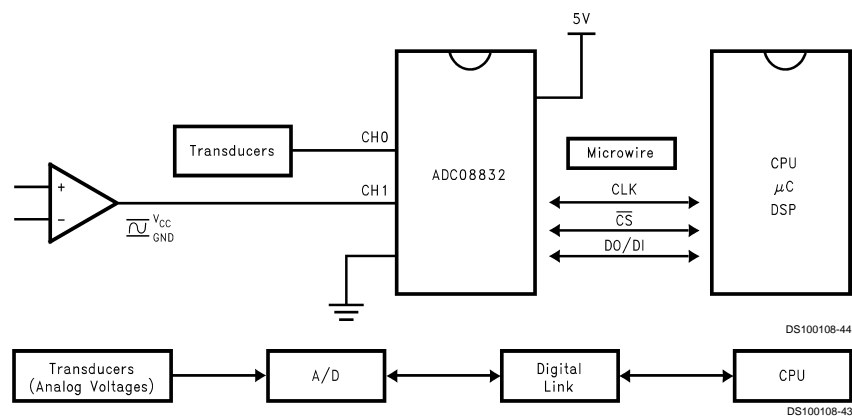

COPS™ is a trademark of National Semiconductor Corporation.
MICROWIRE™ is a trademark of National Semiconductor Corporation.
TRI-STATE™

Connection Diagrams

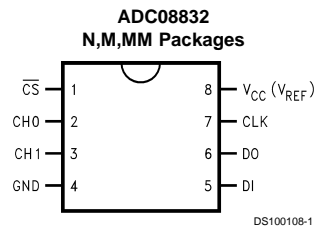
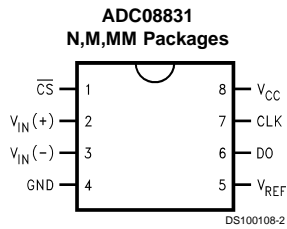
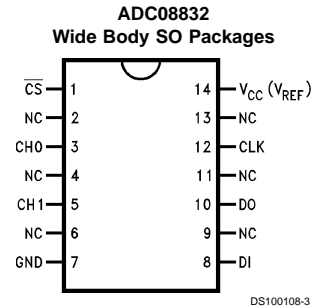
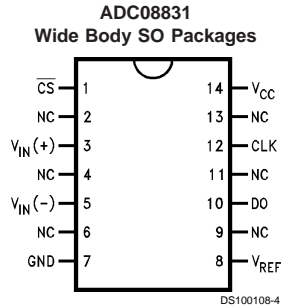

Ordering Information

Temperature Range	Package
Industrial ($-40^{\circ}\text{C} \leq T_J \leq +85^{\circ}\text{C}$)	
ADC08831IN	N08E
ADC08832IN	
ADC08831IWM,	M14B
ADC08832IWM,	
ADC08831IM,	M08A
ADC08832IM,	
ADC08831IMM,	MUA08A
ADC08832IMM,	

Absolute Maximum Ratings (Notes 1, 3)

If Military/Aerospace specified devices are required, please contact the National Semiconductor Sales Office/ Distributors for availability and specifications.

Supply Voltage (V_{CC})	6.5V
Voltage at Inputs and Outputs	-0.3V to $V_{CC} + 0.3V$
Input Current at Any Pin (Note 4)	± 5 mA
Package Input Current (Note 4)	± 20 mA
ESD Susceptibility (Note 6)	
Human Body Model	2000V
Machine Model	200V
Junction Temperature (Note 5)	150°C
Storage Temperature Range	-65° C to 150°C

Mounting Temperature	
Lead Temp. (soldering, 10 sec)	260°C
Infrared (10 sec)	215°C

Operating Ratings (Notes 2, 3)

Temperature Range	-40°C $\leq T_J \leq$ +85°C
Supply Voltage	4.5 V to 6.0 V
Thermal Resistance (θ_{jA})	
SO Package, 8-pin Surface Mount	190°C/W
MSOP, 8-pin Surface Mount	235°C/W
SO Package, 14-pin Surface Mount	145°C/W
N Package, 8-pin	122°C/W
Clock Frequency	10kHz $\leq f_{CLK} \leq$ 2MHz

Electrical Characteristics

The following specifications apply for $V_{CC} = V_{REF} = +5V_{DC}$, and $f_{CLK} = 2$ MHz unless otherwise specified. **Boldface limits apply for $T_A = T_J = T_{MIN}$ to T_{MAX}** ; all other limits $T_A = T_J = 25^\circ C$.

Symbol	Parameter	Conditions	Typical (Note 8)	Limits (Note 9)	Units (Limits)
CONVERTER AND MULTIPLEXER CHARACTERISTICS					
TUE	Total Unadjusted Error	(Note 10)	± 0.3	± 1	LSB (max)
	Offset Error		± 0.2		LSB
DNL	Differential NonLinearity		± 0.2		LSB
INL	Integral NonLinearity		± 0.2		LSB
FS	Full Scale Error		± 0.3		LSB
R_{REF}	Reference Input Resistance	(Note 11)	3.5	2.8 5.9	k Ω (min) k Ω (max)
V_{IN}	Analog Input Voltage	(Note 12)		($V_{CC} + 0.05$) ($GND - 0.05$)	V (max) V (min)
	DC Common-Mode Error			$\pm 1/4$	LSB (max)
	Power Supply Sensitivity	$V_{CC} = 5V \pm 10\%$, $V_{CC} = 5V \pm 5\%$		$\pm 1/4$ $\pm 1/4$	LSB (max) LSB (max)
	On Channel Leakage Current (Note 13)	On Channel = 5V, Off Channel = 0V		0.2 1	μA (max)
		On Channel = 0V Off Channel = 5V		-0.2 -1	μA (min)
	Off Channel Leakage Current (Note 13)	On Channel = 5V, Off Channel = 0V		-0.2 -1	μA (min)
		On Channel = 0V, Off Channel = 5V		0.2 1	μA (max)
DC CHARACTERISTICS					
$V_{IN(1)}$	Logical "1" Input Voltage			2.0	V (min)
$V_{IN(0)}$	Logical "0" Input Voltage			0.8	V (max)
$I_{IN(1)}$	Logical "1" Input Current	$V_{IN} = 5.0V$	0.05	+1	μA (max)
$I_{IN(0)}$	Logical "0" Input Current	$V_{IN} = 0V$	0.05	-1	μA (max)
$V_{OUT(1)}$	Logical "1" Output Voltage	$V_{CC} = 4.75V$: $I_{OUT} = -360 \mu A$ $I_{OUT} = -10 \mu A$		2.4 4.5	V (min) V (min)
$V_{OUT(0)}$	Logical "0" Output Voltage	$V_{CC} = 4.75V$ $I_{OUT} = 1.6$ mA		0.4	V (max)
I_{OUT}	TRI-STATE Output Current	$V_{OUT} = 0V$ $V_{OUT} = 5V$		-3.0 3.0	μA (max) μA (max)
I_{SOURCE}	Output Source Current	$V_{OUT} = 0V$		-6.5	mA (max)
I_{SINK}	Output Sink Current	$V_{OUT} = V_{CC}$		8.0	mA (min)

Electrical Characteristics (Continued)

The following specifications apply for $V_{CC} = V_{REF} = +5V_{DC}$, and $f_{CLK} = 2\text{ MHz}$ unless otherwise specified. **Boldface limits apply for $T_A = T_J = T_{MIN}$ to T_{MAX}** ; all other limits $T_A = T_J = 25^\circ\text{C}$.

Symbol	Parameter	Conditions	Typical (Note 8)	Limits (Note 9)	Units (Limits)
DC CHARACTERISTICS					
I_{CC}	Supply Current ADC08831 CLK = V_{CC}	$\overline{CS} = V_{CC}$	0.6	1.0	mA (max)
		$\overline{CS} = \text{LOW}$	1.7	2.4	mA (max)
I_{CC}	Supply Current ADC08832 CLK = V_{CC} (Note 16)	$\overline{CS} = V_{CC}$	1.3	1.8	mA (max)
		$\overline{CS} = \text{LOW}$	2.4	3.5	mA (max)

Electrical Characteristics

The following specifications apply for $V_{CC} = V_{REF} = +5V_{DC}$, and $t_r = t_f = 20\text{ ns}$ unless otherwise specified. **Boldface limits apply for $T_A = T_J = T_{MIN}$ to T_{MAX}** ; all other limits $T_A = T_J = 25^\circ\text{C}$.

Symbol	Parameter	Conditions	Typical (Note 8)	Limits (Note 9)	Units (Limits)
f_{CLK}	Clock Frequency			2	MHz (max)
	Clock Duty Cycle (Note 14)			40 60	% (min) % (max)
T_C	Conversion Time (Not Including MUX Addressing Time)	$f_{CLK} = 2\text{MHz}$		8 4	$1/f_{CLK}$ (max) μs (max)
t_{CA}	Acquisition Time			$\frac{1}{2}$	$1/f_{CLK}$ (max)
t_{SET-UP}	\overline{CS} Falling Edge or Data Input Valid to CLK Rising Edge			25	ns (min)
t_{HOLD}	Data Input Valid after CLK Rising Edge			20	ns (min)
t_{pd1}, t_{pd0}	CLK Falling Edge to Output Data Valid (Note 15)	$C_L = 100\text{ pF}$: Data MSB First Data LSB First		250 200	ns (max) ns (max)
t_{1H}, t_{0H}	TRI-STATE Delay from Rising Edge of \overline{CS} to Data Output and SARS Hi-Z	$C_L = 10\text{ pF}, R_L = 10\text{ k}\Omega$ (see TRI-STATE Test Circuits)	50		ns
		$C_L = 100\text{ pF}, R_L = 2\text{ k}\Omega$		180	ns (max)
C_{IN}	Capacitance of Analog Input (Note 17)		13		pF
C_{IN}	Capacitance of Logic Inputs		5		pF
C_{OUT}	Capacitance of Logic Outputs		5		pF

Dynamic Characteristics

The following specifications apply for $V_{CC} = 5V$, $f_{CLK} = 2MHz$, $T_A = 25^\circ C$, $R_{SOURCE} = 50\Omega$, $f_{IN} = 45kHz$, $V_{IN} = 5V_P$, $V_{REF} = 5V$, non-coherent 2048 samples with windowing.

Symbol	Parameter	Conditions	Typical (Note 8)	Limits (Note 9)	Units (Limits)
f_s	Sampling Rate ADC08831	$f_{CLK}/11$		181	ksps
	ADC08832	$f_{CLK}/13$ (Note 21)		153	ksps
SNR	Signal-to -Noise Ratio (Note 19)		48.5		dB
THD	Total Harmonic Distortion (Note 20)		-59.5		dB
SINAD	Signal-to -Noise and Distortion		48.0		dB
ENOB	Effective Number Of Bits (Note 18)		7.7		Bits
SFDR	Spurious Free Dynamic Range		62.5		dB

Note 1: Absolute Maximum Ratings indicate limits beyond which damage to the device may occur.

Note 2: Operating Ratings indicate conditions for which the device is functional. These ratings do not guarantee specific performance limits. For guaranteed specifications and test conditions, see the Electrical Characteristics. The guaranteed specifications apply only for the test conditions listed. Some performance characteristics may degrade when the device is not operated under the listed test conditions.

Note 3: All voltages are measured with respect to $GND = 0 V_{DC}$, unless otherwise specified.

Note 4: When the input voltage V_{IN} at any pin exceeds the power supplies ($V_{IN} < (GND)$ or $V_{IN} > V_{CC}$) the current at that pin should be limited to 5 mA. The 20 mA maximum package input current rating limits the number of pins that can safely exceed the power supplies with an input current of 5 mA to four pins.

Note 5: The maximum power dissipation must be derated at elevated temperatures and is dictated by T_{JMAX} , θ_{JA} and the ambient temperature, T_A . The maximum allowable power dissipation at any temperature is $P_D = (T_{JMAX} - T_A)/\theta_{JA}$ or the number given in the Absolute Maximum Ratings, whichever is lower.

Note 6: Human body model, 100 pF capacitor discharged through a 1.5 k Ω resistor. The machine mode is a 200pF capacitor discharged directly into each pin.

Note 7: See AN450 "Surface Mounting Methods and Their Effect on Product Reliability" or Linear Data Book section "Surface Mount" for other methods of soldering surface mount devices.

Note 8: Typical values are at $T_J = 25^\circ C$ and represent the most likely parametric norm.

Note 9: Guaranteed to National's AOQL (Average Outgoing Quality Level).

Note 10: Total Unadjusted Error (TUE) includes offset, full-scale, linearity, multiplexer errors.

Note 11: It is not tested for the ADC08832.

Note 12: For $V_{IN(-)} \geq V_{IN(+)}$ the digital code will be 0000 0000. Two on-chip diodes are tied to each analog input (see Functional Block Diagram) which will forward-conduct for analog input voltages one diode drop below ground or one diode drop greater than V_{CC} supply. During testing at low V_{CC} levels (e.g., 4.5V), high level analog inputs (e.g., 5V) can cause an input diode to conduct, especially at elevated temperatures, which will cause errors for analog inputs near full-scale. The spec allows 50 mV forward bias of either diode; this means that as long as the analog V_{IN} does not exceed the supply voltage by more than 50 mV, the output code will be correct. Exceeding this range on an unselected channel will corrupt the reading of a selected channel. Achievement of an absolute 0 V_{DC} to 5 V_{DC} input voltage range will therefore require a minimum supply voltage of 4.950 V_{DC} over temperature variations, initial tolerance and loading.

Note 13: Channel leakage current is measured after a single-ended channel is selected and the clock is turned off. For off channel leakage current the following two cases are considered: one, with the selected channel tied high (5 V_{DC}) and the remaining off channel tied low (0 V_{DC}), total current flow through the off channel is measured; two, with the selected channel tied low and the off channels tied high, total current flow through the off channel is again measured. The two cases considered for determining on channel leakage current are the same except total current flow through the selected channel is measured.

Note 14: A 40% to 60% duty cycle range insures proper operation at all clock frequencies. In the case that an available clock has a duty cycle outside of these limits the minimum time the clock is high or low must be at least 250 ns. The maximum time the clock can be high or low is 60 μs .

Note 15: Since data, MSB first, is the output of the comparator used in the successive approximation loop, an additional delay is built in to allow for comparator response time.

Note 16: For the ADC08832 V_{ref} is internally tied to V_{CC} , therefore, for the ADC08832 reference current is included in the supply current.

Note 17: Analog inputs are typically 300 ohms input resistance to a 13pF sample and hold capacitor.

Note 18: Effective Number Of Bits (ENOB) is calculated from the measured signal-to-noise plus distortion ratio (SINAD) using the equation $ENOB = (SINAD - 1.76) / 6.02$.

Note 19: The signal-to-noise ratio is the ratio of the signal amplitude to the background noise level. Harmonics of the input signal are not included in its calculation.

Note 20: The contributions from the first 6 harmonics are used in the calculation of the THD.

Note 21: The maximum sampling rate is slightly less than $f_{CLK}/11$ if \overline{CS} is reset in less than one clock period.

Block Diagram

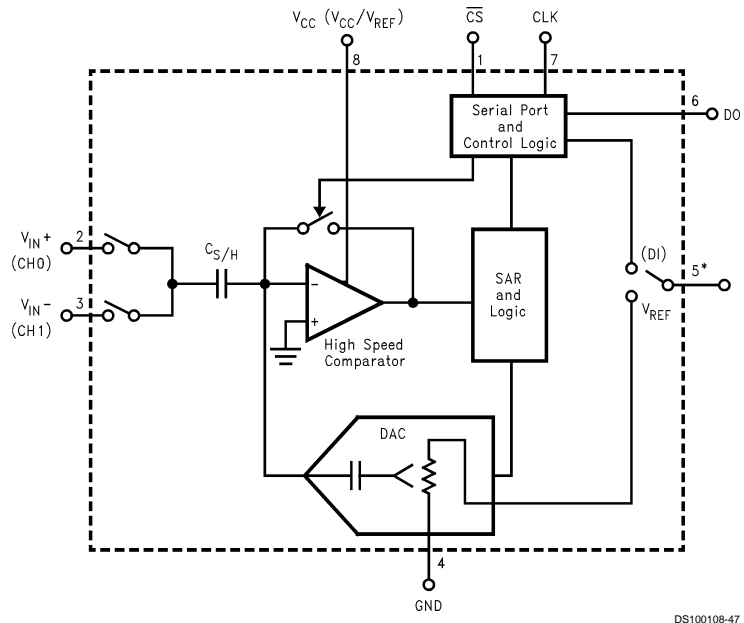

DS100108-47

*For ADC08831 V_{REF} pin is available, for ADC08832 DI pin is available, and V_{REF} is tied to V_{CC}
Pin names in parentheses refer to ADC08832

Typical Performance Characteristics The following specifications apply for $T_A = 25^\circ\text{C}$, $V_{CC} = V_{REF} = 5\text{V}$, unless otherwise specified.

Linearity Error (TUE) vs Reference Voltage

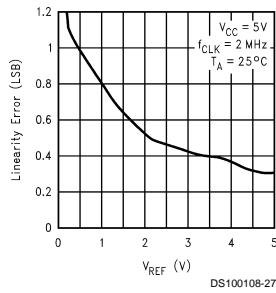

Linearity Error (TUE) vs Temperature

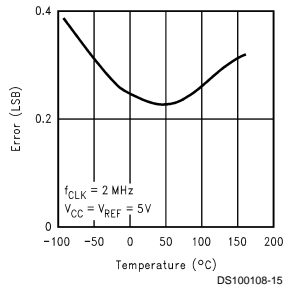

Linearity Error (TUE) vs Clock Frequency

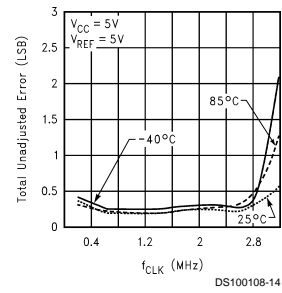

Power Supply Current vs Temperature (ADC08831)

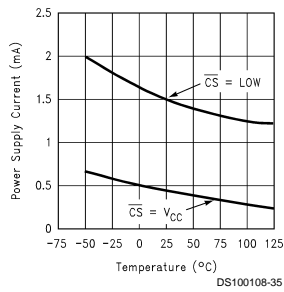

Power Supply Current vs Temperature (ADC08832)

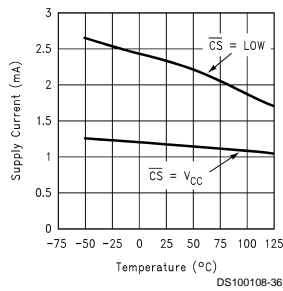

Power Supply Current vs Clock Frequency, $\overline{CS} = \text{Low}$, ADC08831

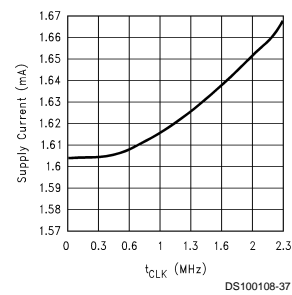

Output Current vs Temperature

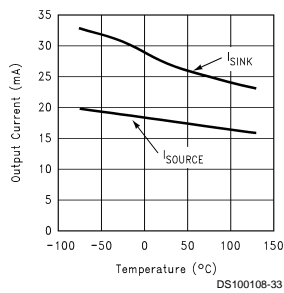

Typical Performance Characteristics The following specifications apply for $T_A = 25^\circ\text{C}$, $V_{CC} = V_{REF} = 5\text{V}$, unless otherwise specified. (Continued)

Spectral Response with 10KHz Sine Wave Input

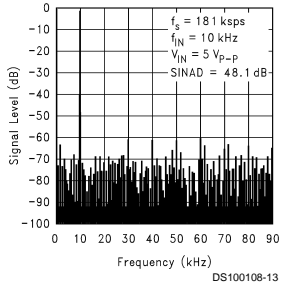

Spectral Response with 55 KHz Sine Wave Input

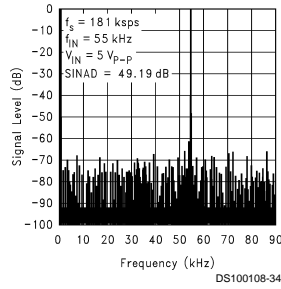

Spectral Response with 90 KHz Sine Wave Input

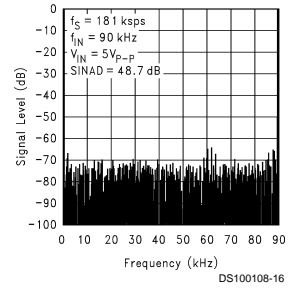

Total Unadjusted Error Plot

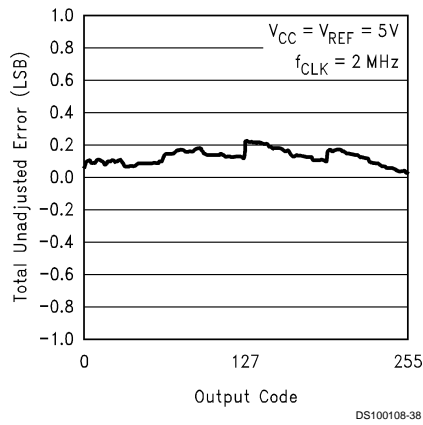

Leakage Current Test Circuit

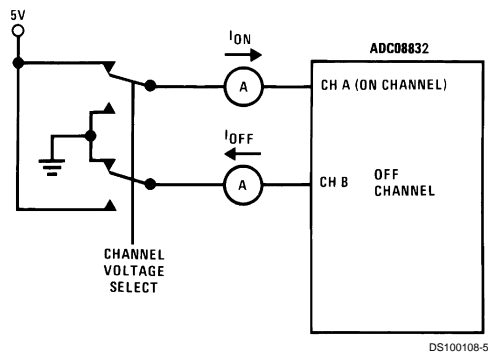

TRI-STATE Test Circuits and Waveforms

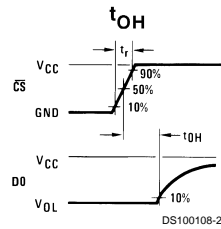
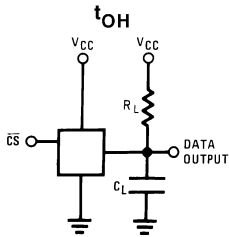
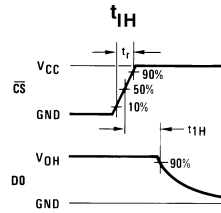
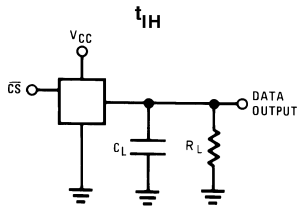

DS100108-20

DS100108-21

Timing Diagrams

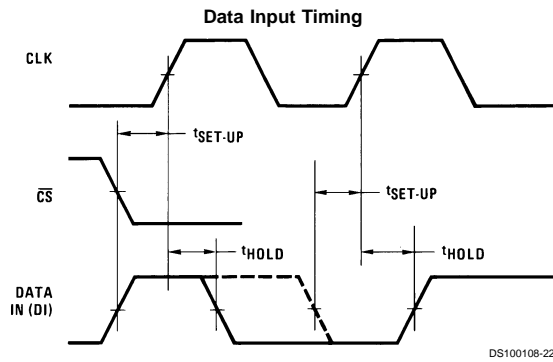

DS100108-22

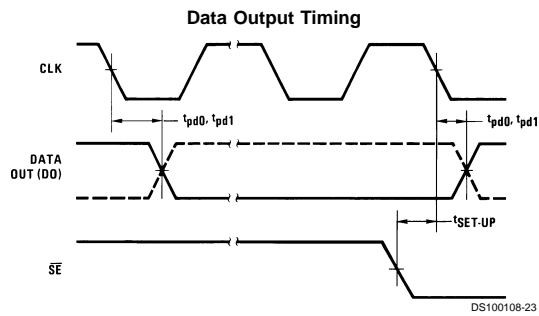

DS100108-23

Timing Diagrams (Continued)

ADC08831 Start Conversion Timing

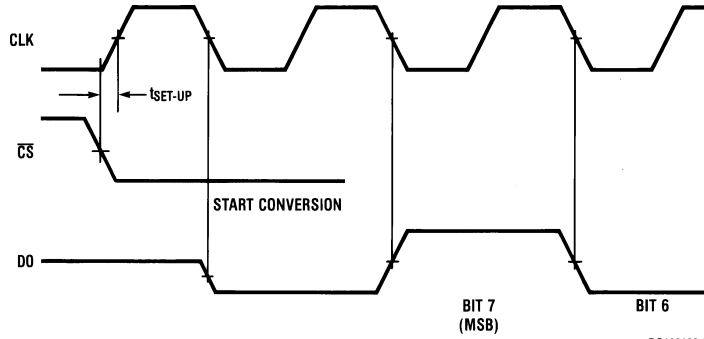

ADC08831 Timing

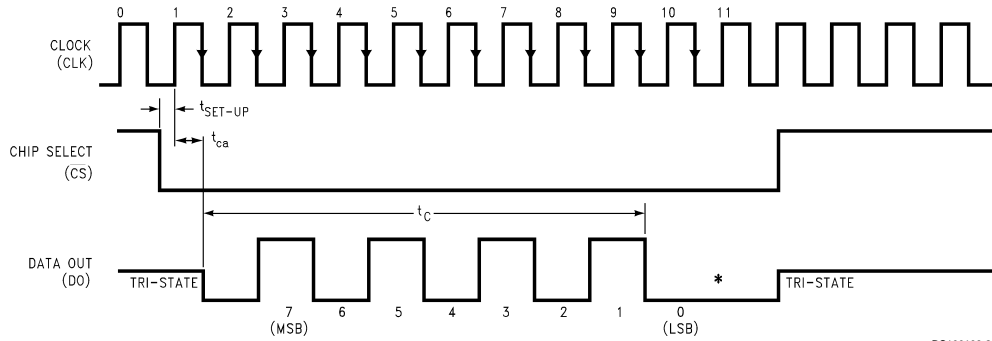

*LSB first output not available on ADC08831.

ADC08832 Timing

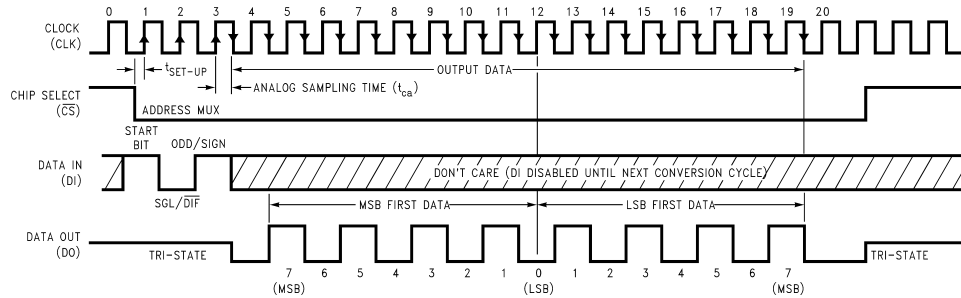

ADC08832 Functional Block Diagram

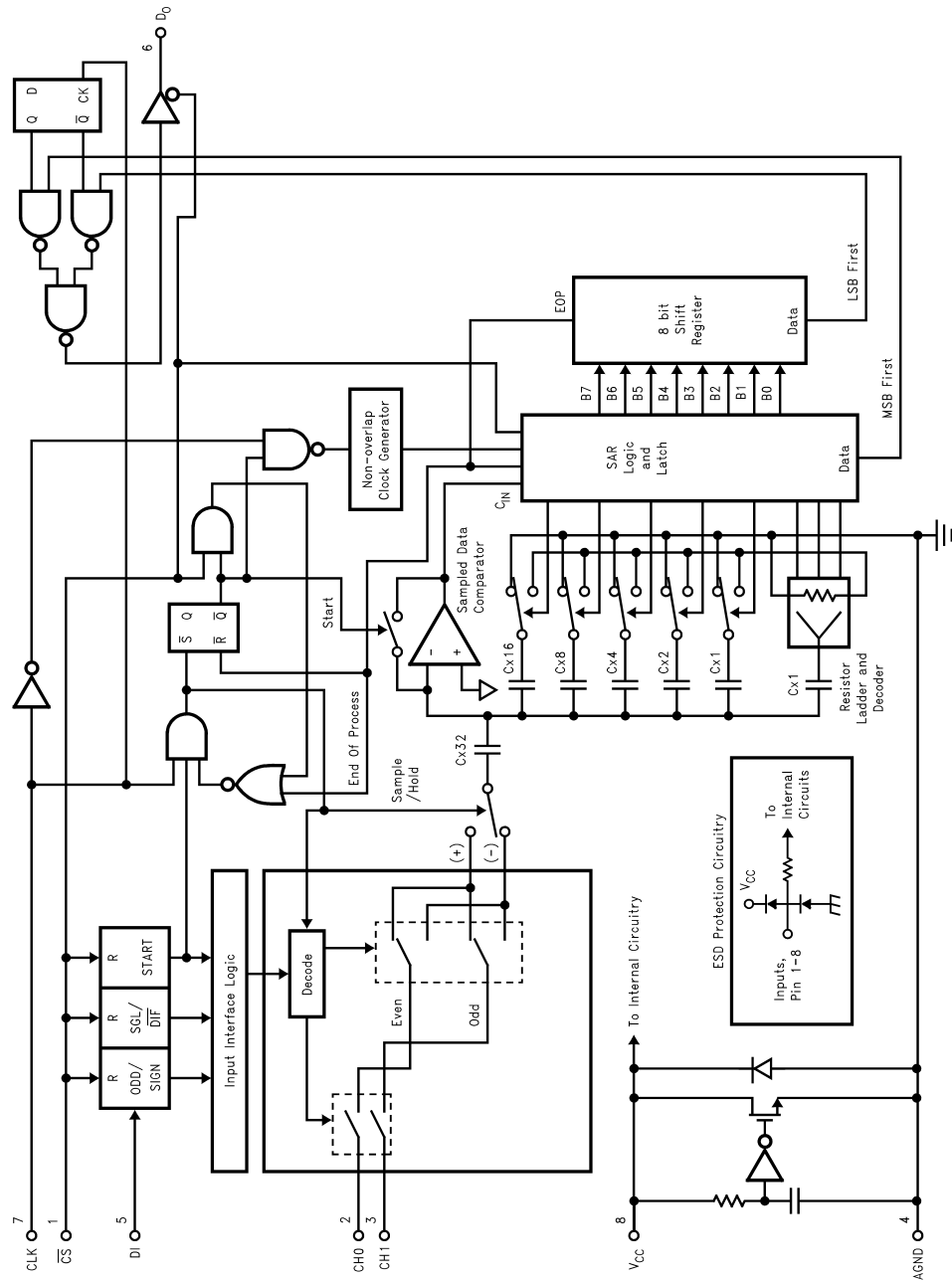

DS10008-12

*Some of these functions/pins are not available with other options.

Functional Description

1.0 MULTIPLEXER ADDRESSING

The design of these converters utilizes a comparator structure with built-in sample-and-hold which provides for a differential analog input to be converted by a successive approximation routine.

The actual voltage converted is always the difference between an assigned "+" input terminal and a "-" input terminal. The polarity of each input terminal of the pair indicates which line the converter expects to be the most positive. If the assigned "+" input voltage is less than the "-" input voltage the converter responds with an all zeros output code.

A unique input multiplexing scheme has been utilized to provide multiple analog channels with software-configurable single-ended, or differential operation. The analog signal conditioning required in transducer-based data acquisition systems is significantly simplified with this type of input flexibility. One converter package can now handle ground referenced inputs, differential inputs, as well as signals with some arbitrary reference voltage.

A particular input configuration is assigned during the MUX addressing sequence, prior to the start of a conversion. The MUX address selects which of the analog inputs are to be enabled and whether this input is single-ended or differential. In addition to selecting differential mode the polarity may also be selected. Channel 0 may be selected as the positive input and channel 1 as the negative input or vice versa. This programmability is illustrated by the MUX addressing codes for the ADC08832.

The MUX address is shifted into the converter via the DI line. Because the ADC08831 contains only one differential input channel with a fixed polarity assignment, it does not require addressing.

TABLE 1. Multiplexer/Package Options

Part Number	Number of Analog Channels		Number of Package Pins
	Single-Ended	Differential	
ADC08831	1	1	8 or 14
ADC08832	2	1	8 or 14

MUX Addressing: ADC08832

Single-Ended MUX Mode				
MUX Address			Channel #	
Start Bit	SGL/ DIF	ODD/ SIGN	0	1
1	1	0	+	
1	1	1		+

Differential MUX Mode				
MUX Address			Channel #	
Start Bit	SGL/ DIF	ODD/ SIGN	0	1
1	0	0	+	-
1	0	1	-	+

Since the input configuration is under software control, it can be modified as required before each conversion. A channel can be treated as a single-ended, ground referenced input for one conversion; then it can be reconfigured as part of a differential channel for another conversion.

The analog input voltages for each channel can range from 50mV below ground to 50mV above V_{CC} (typically 5V) without degrading conversion accuracy.

2.0 THE DIGITAL INTERFACE

A most important characteristic of these converters is their serial data link with the controlling processor. Using a serial communication format offers two very significant system improvements. It allows many functions to be included in a small package and it can eliminate the transmission of low level analog signals by locating the converter right at the analog sensor; transmitting highly noise immune digital data back to the host processor.

To understand the operation of these converters it is best to refer to the Timing Diagrams and Functional Block Diagram and to follow a complete conversion sequence. For clarity, a separate timing diagram is shown for each device.

1. A conversion is initiated by pulling the \overline{CS} (chip select) line low. This line must be held low for the entire conversion. The converter is now waiting for a start bit and its MUX assignment word, if applicable.
2. On each rising edge of the clock the status of the data in (DI) line is clocked into the MUX address shift register. The start bit is the first logic "1" that appears on this line (all leading zeros are ignored). Following the start bit the converter expects the next 2 bits to be the MUX assignment word.
3. When the start bit has been shifted into the start location of the MUX register, and the input channel has been assigned, a conversion is about to begin. An interval of $\frac{1}{2}$ clock period (where nothing happens) is automatically inserted to allow the selected MUX channel to settle to a final analog input value. The DI line is disabled at this time. It no longer accepts data.
4. The data out (DO) line now comes out of TRI-STATE and provides a leading zero for this one clock period of MUX settling time.
5. During the conversion the output of the SAR comparator indicates whether the analog input is greater than (high) or less than (low) a series of successive voltages generated internally from a ratioed capacitor array (first 5 bits) and a resistor ladder (last 3 bits). After each comparison the comparator's output is shipped to the DO line on the falling edge of CLK. This data is the result of the conversion being shifted out (with the MSB first) and can be read by the processor immediately.
6. After 8 clock periods the conversion is completed.
7. The stored data in the successive approximation register is loaded into an internal shift register. The data, LSB first, is automatically shifted out the DO line after the MSB first data stream. The DO line then goes low and stays low until \overline{CS} is returned high. The ADC08831 is an exception in that its data is only output in MSB first format.
8. The DI and DO lines can be tied together and controlled through a bidirectional processor I/O bit with one wire. This is possible because the DI input is only "looked-at" during the MUX addressing interval while the DO line is still in a high impedance state.

Functional Description (Continued)

3.0 Reducing Power Consumption

The ADC08831 operate up to a 2MHz clock frequency, or about 181 ksp/s. At 5V supply, it consumes about 1.7 mA or 8.5 mW when \overline{CS} is logic low. The ADC08831 has a low power mode to minimize total power consumption.

When the chip select is asserted with a logic high, some analog circuitry and digital logic are pulled to a static, low power condition. Also, DOUT, the output driver is taken into TRI-STATE mode.

To optimize static power consumption, special attention is needed to the digital input logic signals: CLK, \overline{CS} , DI. Each digital input has a large CMOS buffer between V_{CC} and GND. A traditional TTL level high (2.4V) will be sufficient for each input to read a logical "1". However, there could be a large V_{IH} to V_{CC} voltage difference at each input. Such a voltage difference would cause static power dissipation, even when chip select pin is high and the part is in low power mode.

Therefore, to minimize static power dissipation, it is recommended that all digital input logic levels should equal the converter's supply. Various CMOS logic is particularly well suited for this application.

The reference pin on the ADC08831 is not affected by the power-down mode. To reduce static reference current during non-conversion time, there are a couple options. First, a low voltage external reference (ie, 2.5V could be used). A shunt reference, such as the LM385-2.5, could be powered by a logic gate that is the inverse of the signal on \overline{CS} . When \overline{CS} is high, the reference is off. As a second option, an external, low on-resistance switch could be used.

The ADC08832 is similar to the ADC08831, except its reference is derived from V_{CC} . The ADC08832 does enter a low-power mode when \overline{CS} is logic high, as the analog and

digital logic enter static current modes. However power dissipation from the reference ladder occurs, regardless of the signal on \overline{CS}

4.0 REFERENCE CONSIDERATIONS

The voltage applied to the reference input on these converters, V_{REF} , defines the voltage span of the analog input (the difference between $V_{IN(MAX)}$ and $V_{IN(MIN)}$) over which the 256 possible output codes apply. The devices can be used either in ratiometric applications or in systems requiring absolute accuracy. The reference pin must be connected to a voltage source capable of driving the reference input resistance which can be as low as 2.8k Ω . This pin is the top of a resistor divider string and capacitor array used for the successive approximation conversion.

In a ratiometric system the analog input voltage is proportional to the voltage used for the A/D reference. This voltage is typically the system power supply, so the V_{REF} pin can be tied to V_{CC} (done internally on the ADC08832). This technique relaxes the stability requirements of the system reference as the analog input and A/D reference move together maintaining the same output code for a given input condition.

For absolute accuracy, where the analog input varies between very specific voltage limits, the reference pin can be biased with a time and temperature stable voltage source. The LM385, LM336 and LM4040 reference diodes are good low current devices to use with these converters.

The maximum value of the reference is limited to the V_{CC} supply voltage. The minimum value, however, can be quite small (see Typical Performance Characteristics) to allow direct conversions of transducer outputs providing less than a 5V output span. Particular care must be taken with regard to noise pickup, circuit layout and system error voltage sources when operating with a reduced span due to the increased sensitivity of the converter (1 LSB equals $V_{REF}/256$).

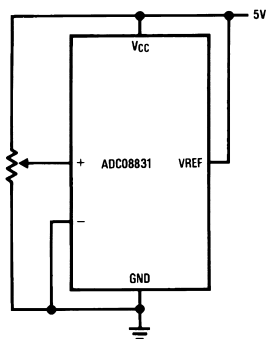

DS100108-28

a) Ratiometric

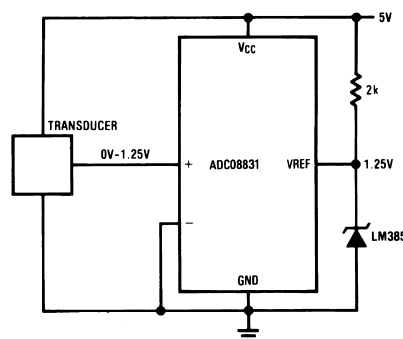

DS100108-29

b) Absolute with a Reduced Span

FIGURE 1. Reference Examples

Functional Description (Continued)

5.0 THE ANALOG INPUTS

The most important feature of these converters is that they can be located right at the analog signal source and through just a few wires can communicate with a controlling processor with a highly noise immune serial bit stream. This in itself greatly minimizes circuitry to maintain analog signal accuracy which otherwise is most susceptible to noise pickup. However, a few words are in order with regard to the analog inputs should the input be noisy to begin with or possibly riding on a large common-mode voltage.

The differential input of these converters actually reduces the effects of common-mode input noise, a signal common to both selected "+" and "-" inputs for a conversion (60 Hz is most typical). The time interval between sampling the "+" input and then the "-" input is $\frac{1}{2}$ of a clock period. The change in the common-mode voltage during this short time interval can cause conversion errors. For a sinusoidal common-mode signal this error is:

$$V_{\text{error(max)}} = V_{\text{PEAK}}(2\pi f_{\text{CM}}) \left(\frac{0.5}{f_{\text{CLK}}} \right)$$

where f_{CM} is the frequency of the common-mode signal,

V_{PEAK} is its peak voltage value

and f_{CLK} is the A/D clock frequency.

For a 60Hz common-mode signal to generate a $\frac{1}{4}$ LSB error ($\approx 5\text{mV}$) with the converter running at 250kHz, its peak value would have to be 6.63V which would be larger than allowed as it exceeds the maximum analog input limits.

Source resistance limitation is important with regard to the DC leakage currents of the input multiplexer. Bypass capacitors should not be used if the source resistance is greater than $1\text{k}\Omega$. The worst-case leakage current of $\pm 1\mu\text{A}$ over temperature will create a 1mV input error with a $1\text{k}\Omega$ source resistance. An op amp RC active low pass filter can provide both impedance buffering and noise filtering should a high impedance signal source be required.

5.1 Sample and Hold

The ADC08831/2 provide a built-in sample-and-hold to acquire the input signal. The sample and hold can sample input signals in either single-ended or pseudo differential mode.

5.2 Input Op Amps

When driving the analog inputs with an op amp it is important that the op amp settle within the allowed time. To achieve the full sampling rate, the analog input should be driven with a low impedance source (100Ω) or a high-speed op amp such as the LM6142. Higher impedance sources or slower op amps can easily be accommodated by allowing more time for the analog input to settle.

5.3 Source Resistance

The analog inputs of the ADC08831/2 look like a 13pF capacitor (C_{IN}) in series with 300Ω resistor (R_{on}). C_{IN} gets switched between the selected "+" and "-" inputs during each conversion cycle. Large external source resistors will slow the settling of the inputs. It is important that the overall RC time constants be short enough to allow the analog input to completely settle.

5.4 Board Layout Consideration, Grounding and Bypassing:

The ADC08831/2 are easy to use with some board layout consideration. They should be used with an analog ground plane and single-point grounding techniques. The GND pin should be tied directly to the ground plane.

The supply pin should be bypassed to the ground plane with a surface mount or ceramic capacitor with leads as short as possible. All analog inputs should be referenced directly to the single-point ground. Digital inputs and outputs should be shielded from and routed away from the reference and analog circuitry.

6.0 OPTIONAL ADJUSTMENTS

6.1 Zero Error

The offset of the A/D does not require adjustment. If the minimum analog input voltage value, $V_{\text{IN(MIN)}}$, is not ground a zero offset can be done. The converter can be made to output 0000 0000 digital code for this minimum input voltage by biasing any $V_{\text{IN}}(-)$ input at this $V_{\text{IN(MIN)}}$ value. This utilizes the differential mode operation of the A/D.

The zero error of the A/D converter relates to the location of the first riser of the transfer function and can be measured by grounding the $V_{\text{IN}}(-)$ input and applying a small magnitude positive voltage to the $V_{\text{IN}}(+)$ input. Zero error is the difference between the actual DC input voltage which is necessary to just cause an output digital code transition from 0000 0000 to 0000 0001 and the ideal $\frac{1}{2}$ LSB value ($\frac{1}{2}$ LSB = 9.8mV for $V_{\text{REF}} = 5.000V_{\text{DC}}$).

6.2 Full Scale

The full-scale adjustment can be made by applying a differential input voltage which is $1\frac{1}{2}$ LSB down from the desired analog full-scale voltage range and then adjusting the magnitude of the V_{REF} input (or V_{CC} for the ADC08832) for a digital output code which is just changing from 1111 1110 to 1111 1111.

6.3 Adjusting for an Arbitrary Analog Input Voltage Range

If the analog zero voltage of the A/D is shifted away from ground (for example, to accommodate an analog input signal which does not go to ground), this new zero reference should be properly adjusted first. A $V_{\text{IN}}(+)$ voltage which equals this desired zero reference plus $\frac{1}{2}$ LSB (where the LSB is calculated for the desired analog span, using $1\text{ LSB} = \text{analog span}/256$) is applied to selected "+" input and the zero reference voltage at the corresponding "-" input should then be adjusted to just obtain the 00_{HEX} to 01_{HEX} code transition.

The full-scale adjustment should be made [with the proper $V_{\text{IN}}(-)$ voltage applied] by forcing a voltage to the $V_{\text{IN}}(+)$ input which is given by:

$$V_{\text{IN}}(+)\text{ fs adj} = V_{\text{MAX}} - 1.5 \left[\frac{(V_{\text{MAX}} - V_{\text{MIN}})}{256} \right]$$

where:

V_{MAX} = the high end of the analog input range

and

V_{MIN} = the low end (the offset zero) of the analog range.

(Both are ground referenced.)

Functional Description (Continued)

The V_{REFIN} (or V_{CC}) voltage is then adjusted to provide a code change from FE_{HEX} to FF_{HEX} . This completes the adjustment procedure.

7.0 DYNAMIC PERFORMANCE

Dynamic performance specifications are often useful in applications requiring waveform sampling and digitization. Typically, a memory buffer is used to capture a stream of consecutive digital outputs for post processing. Capturing a number of samples that is a power of 2 (ie, 1024, 2048, 4096) allows the Fast Fourier Transform (FFT) to be used to digitally analyze the frequency components of the signal. Depending on the application, further digital filtering, windowing, or processing can be applied.

7.1 Sampling Rate

The Sampling Rate, sometimes referred to as the Throughput Rate, is the time between repetitive samples by an Analog-to-Digital Converter. The sampling rate includes the conversion time, as well as other factors such as a MUX setup time, acquisition time, and interfacing time delays. Typically, the sampling rate is specified in the number of samples taken per second, at the maximum Analog-to-Digital Converter clock frequency.

Signals with frequencies exceeding the Nyquist frequency (1/2 the sampling rate), will be aliased into frequencies below the Nyquist frequency. To prevent signal degradation, sample at twice (or more) than the input signal and/or use of a low pass (anti-aliasing) filter on the front-end. Sampling at a much higher rate than the input signal will reduce the requirements of the anti-aliasing filter.

Some applications require under-sampling the input signal. In this case, one expects the fundamental to be aliased into the frequency range below the Nyquist frequency. In order to be assured the frequency response accurately represents a harmonic of the fundamental, a band-pass filter should be used over the input range of interest.

7.2 Signal-to-Noise Ratio

Signal-to-Noise Ratio (SNR) is the ratio of RMS magnitude of the fundamental to the RMS sum of all the non-fundamental signal, excluding the harmonics, up to 1/2 of the sampling frequency (Nyquist).

7.3 Total Harmonic Distortion

Total Harmonic distortion is the ratio of the RMS sum of the amplitude of the harmonics to the fundamental input frequency.

$$THD = 20 \log [(V_2^2 + V_3^2 + V_4^2 + V_5^2 + V_6^2)^{1/2} / V_1]$$

Where V_1 is the RMS amplitude of the fundamental and V_2, V_3, V_4, V_5, V_6 are the RMS amplitudes of the individual harmonics. In theory, all harmonics are included in THD calculations, but in practice only about the first 6 make significant contributions and require measurement.

For under-sampling applications, the input signal should be band pass filtered (BPF) to prevent out of band signals, or their harmonics, to appear in the spectral response.

The DC Linearity transfer function of an Analog-to-Digital Converter tends to influence the dominant harmonics. A parabolic Linearity curve would tend to create 2nd (and even) order harmonics, while an S-curve would tend to create 3rd (or odd) order harmonics. The magnitude of an DC linearity error correlates to the magnitude of the harmonics.

7.4 Signal-to-Noise and Distortion

Signal-to-Noise And Distortion ratio (SINAD) is the ratio of RMS magnitude of the fundamental to the RMS sum of all the non-fundamental signals, including the noise and harmonics, up to 1/2 of the sampling frequency (Nyquist), excluding DC.

SINAD is also dependent on the number of quantization levels in the A/D Converter used in the waveform sampling process. The more quantization levels, the smaller the quantization noise and theoretical noise performance. The theoretical SINAD for a N-Bit Analog-to-Digital Converter is given by:

$$SINAD = (6.02 N + 1.76) \text{ dB}$$

Thus, for an 8-bit converter, the ideal SINAD = 49.92 dB

7.5 Effective Number of Bits

Effective Number Of Bits (ENOB) is another specification to quantify dynamic performance. The equation for ENOB is given by:

$$ENOB = [(SINAD - 1.76)] / 6.02]$$

The Effective Number Of Bits portrays the cumulative effect of several errors, including quantization, non-linearities, noise, and distortion.

7.6 Spurious Free Dynamic Range

Spurious Free Dynamic Range (SFDR) is the ratio of the signal amplitude to the amplitude of the highest harmonic or spurious noise component. If the amplitude is at full scale, the specification is simply the reciprocal of the peak harmonic or spurious noise.

Applications (Continued)

Span Adjust; $0V \leq V_{IN} \leq 3V$

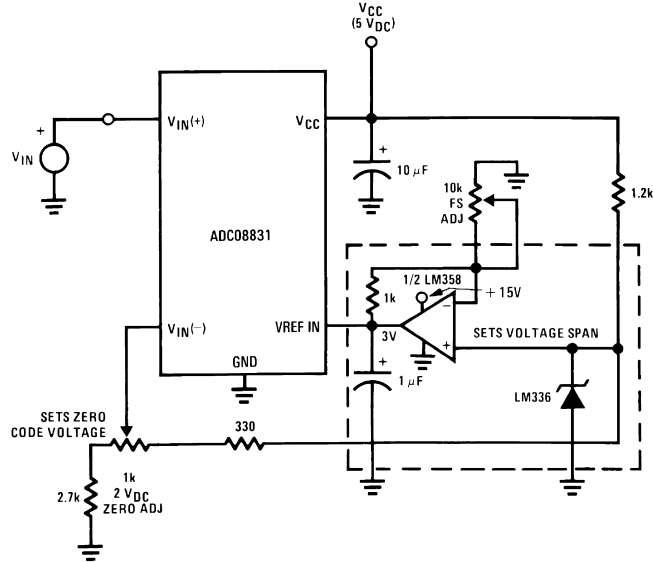
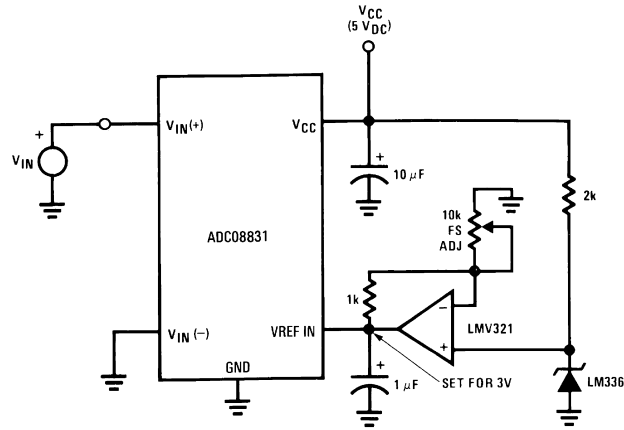

Zero-Shift and Span Adjust: $2V \leq V_{IN} \leq 5V$

DS100108-8

Applications (Continued)

Protecting the Input

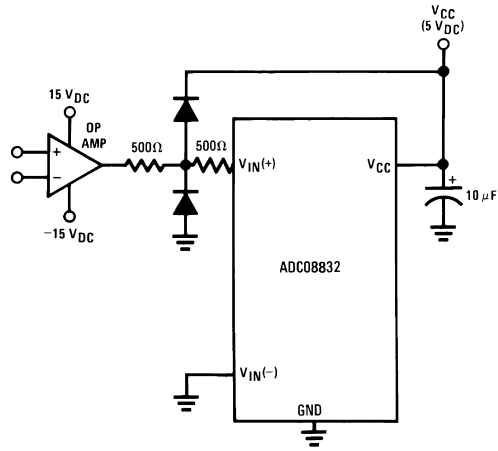

DS100108-9

Diodes are 1N914

Digital Load Cell

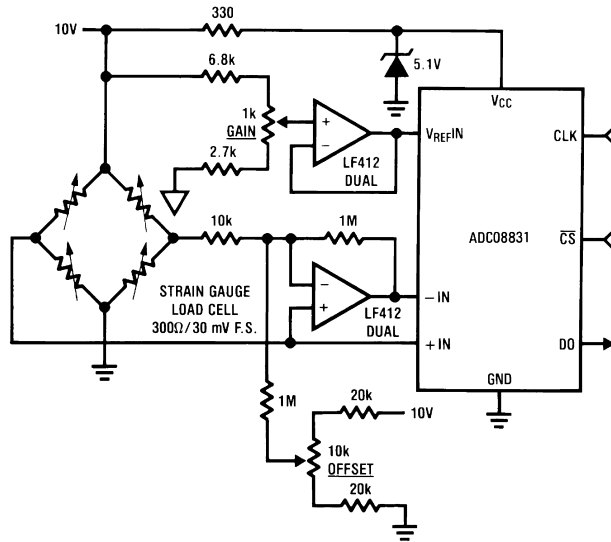

DS100108-10

- Uses one more wire than load cell itself
- Two mini-DIPs could be mounted inside load cell for digital output transducer
- Electronic offset and gain trims relax mechanical specs for gauge factor and offset
- Low level cell output is converted immediately for high noise immunity

Applications (Continued)

4 mA-20 mA Current Loop Converter

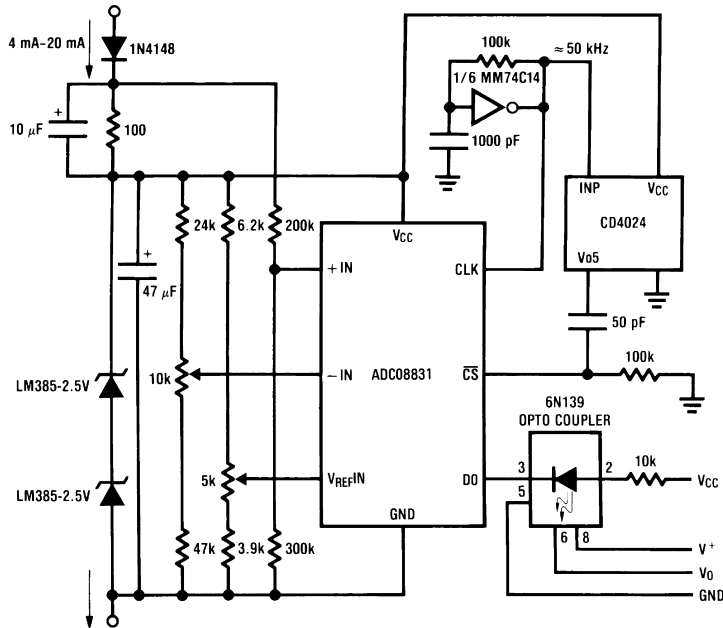

DS100108-11

- All power supplied by loop
- 1500V isolation at output

Isolated Data Converter

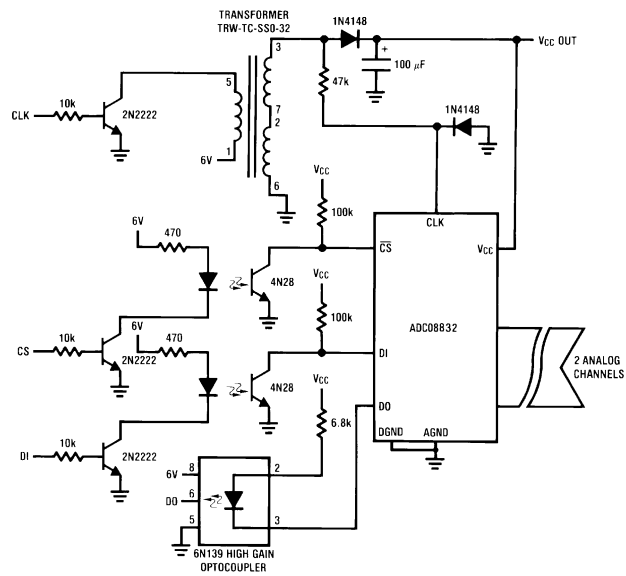

DS100108-40

Applications (Continued)

A "Stand-Alone" Hook-Up for ADC08832 Evaluation

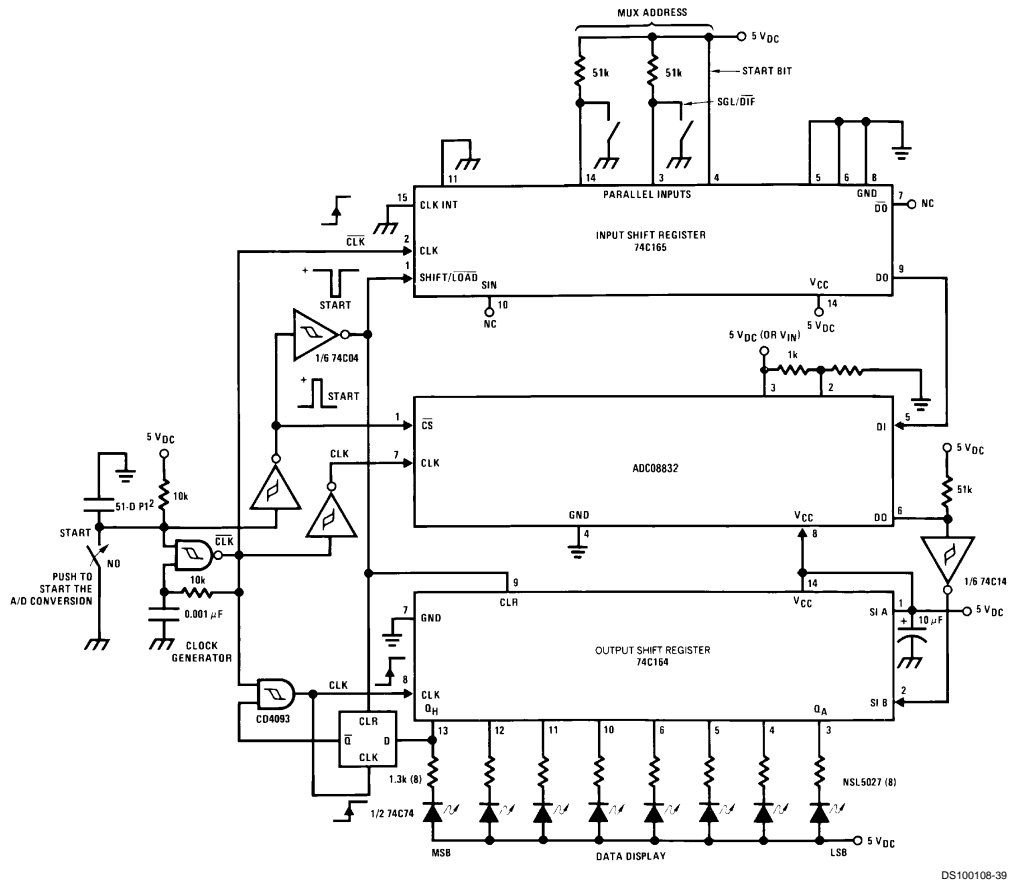

DS100108-39

Physical Dimensions inches (millimeters) unless otherwise noted

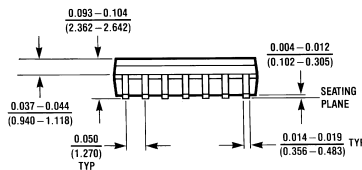
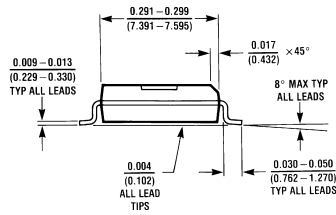
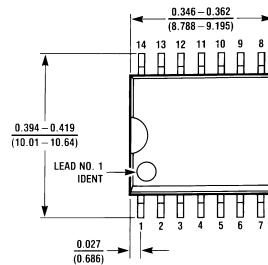

M14B (REV D)

**Order Number ADC08831IWM, ADC08832IWM,
NS Package Number M14B**

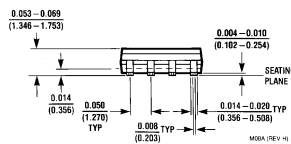
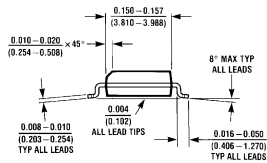
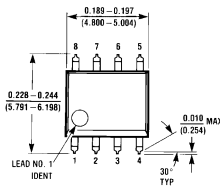

M08A (REV H)

**Order Number ADC08831IM or ADC08832IM
NS Package Number M08A**

Physical Dimensions inches (millimeters) unless otherwise noted (Continued)

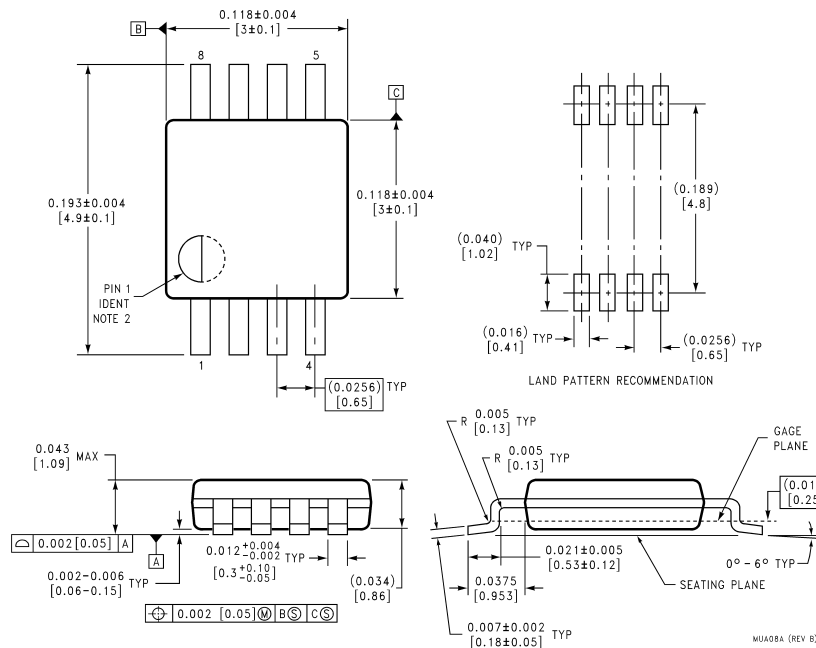

**Order Number ADC08831IMM or ADC08832IMM
NS Package Number MUA08A**

LIFE SUPPORT POLICY

NATIONAL'S PRODUCTS ARE NOT AUTHORIZED FOR USE AS CRITICAL COMPONENTS IN LIFE SUPPORT DEVICES OR SYSTEMS WITHOUT THE EXPRESS WRITTEN APPROVAL OF THE PRESIDENT AND GENERAL COUNSEL OF NATIONAL SEMICONDUCTOR CORPORATION. As used herein:

1. Life support devices or systems are devices or systems which, (a) are intended for surgical implant into the body, or (b) support or sustain life, and whose failure to perform when properly used in accordance with instructions for use provided in the labeling, can be reasonably expected to result in a significant injury to the user.
2. A critical component is any component of a life support device or system whose failure to perform can be reasonably expected to cause the failure of the life support device or system, or to affect its safety or effectiveness.

National Semiconductor Corporation
Americas
Tel: 1-800-272-9959
Fax: 1-800-737-7018
Email: support@nsc.com
www.national.com

National Semiconductor Europe
Fax: +49 (0) 1 80-530 85 86
Email: europe.support@nsc.com
Deutsch Tel: +49 (0) 1 80-530 85 85
English Tel: +49 (0) 1 80-532 78 32
Français Tel: +49 (0) 1 80-532 93 58
Italiano Tel: +49 (0) 1 80-534 16 80

National Semiconductor Asia Pacific Customer Response Group
Tel: 65-2544466
Fax: 65-2504466
Email: sea.support@nsc.com

National Semiconductor Japan Ltd.
Tel: 81-3-5639-7560
Fax: 81-3-5639-7507

National does not assume any responsibility for use of any circuitry described, no circuit patent licenses are implied and National reserves the right at any time without notice to change said circuitry and specifications.