

# ASSP For power supply applications

BIPOLAR

## Power Supply Monitor

# MB3771

### DESCRIPTION

The Fujitsu MB3771 is designed to monitor the voltage level of one or two power supplies (+5 V and an arbitrary voltage) in a microprocessor circuit, memory board in large-size computer, for example.

If the circuit's power supply deviates more than a specified amount, then the MB3771 generates a reset signal to the microprocessor. Thus, the computer data is protected from accidental erasure.

Using the MB3771 requires few external components. To monitor only a +5 V supply, the MB3771 requires the connection of one external capacitor. The level of an arbitrary detection voltage is determined by two external resistors. The MB3771 is available in an 8-pin Dual In-Line, Single In-Line Package or space saving Flat Package.

### FEATURES

- Precision voltage detection ( $V_{SA} = 4.2 \text{ V} \pm 2.5 \%$ )
- User selectable threshold level with hysteresis ( $V_{SB} = 1.23 \text{ V} \pm 1.5 \%$ )
- Monitors the voltage of one or two power supplies (5 V and an arbitrary voltage,  $>1.23 \text{ V}$ )
- Usable as over voltage detector
- Low voltage output for reset signal ( $V_{CC} = 0.8 \text{ V Typ}$ )
- Minimal number of external components (one capacitor Min)
- Low power dissipation ( $I_{CC} = 0.35 \text{ mA Typ}$ ,  $V_{CC} = 5 \text{ V}$ )
- Detection threshold voltage has hysteresis function
- Reference voltage is connectable.

### PACKAGES

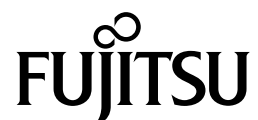
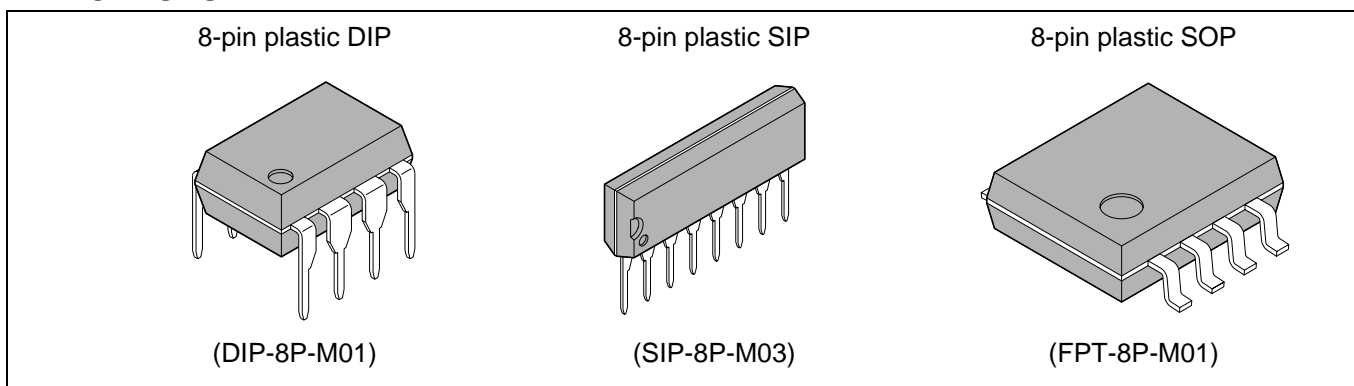

# MB3771

## PIN ASSIGNMENT

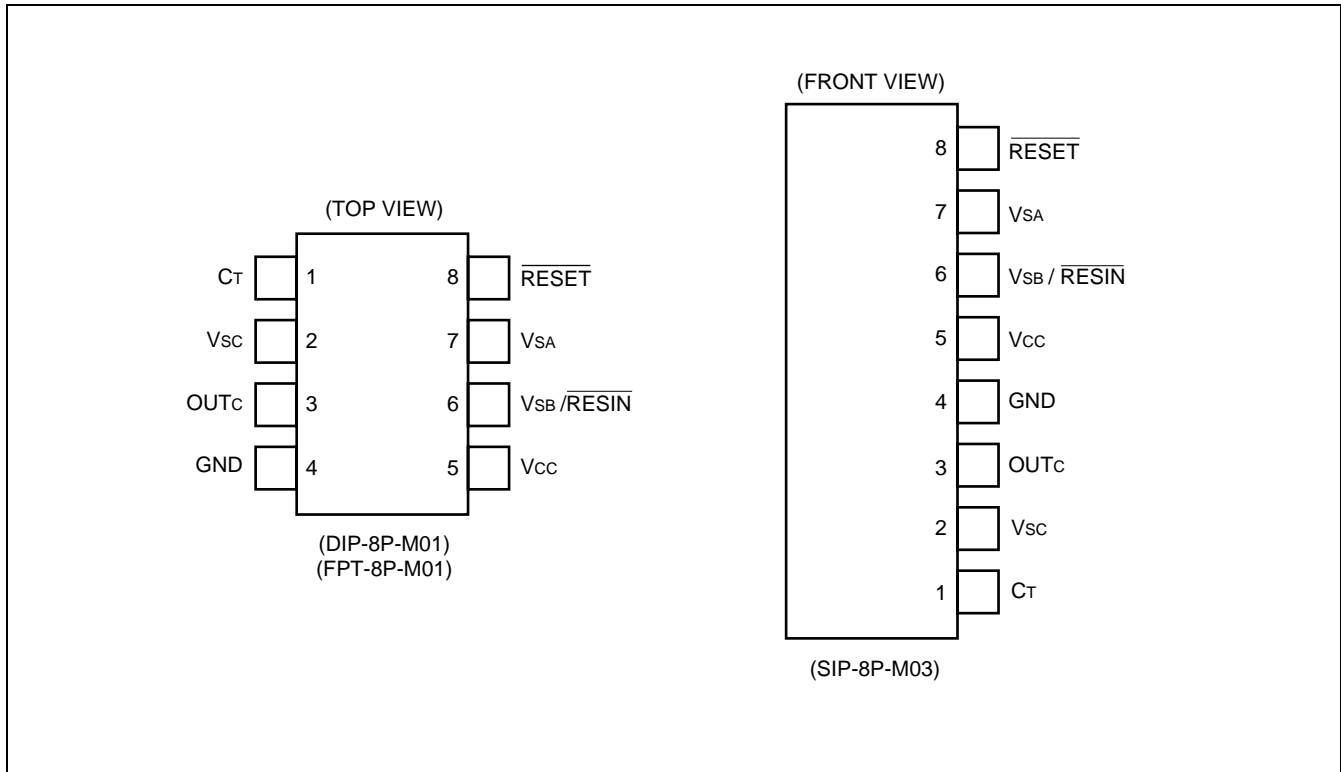

## BLOCK DIAGRAM

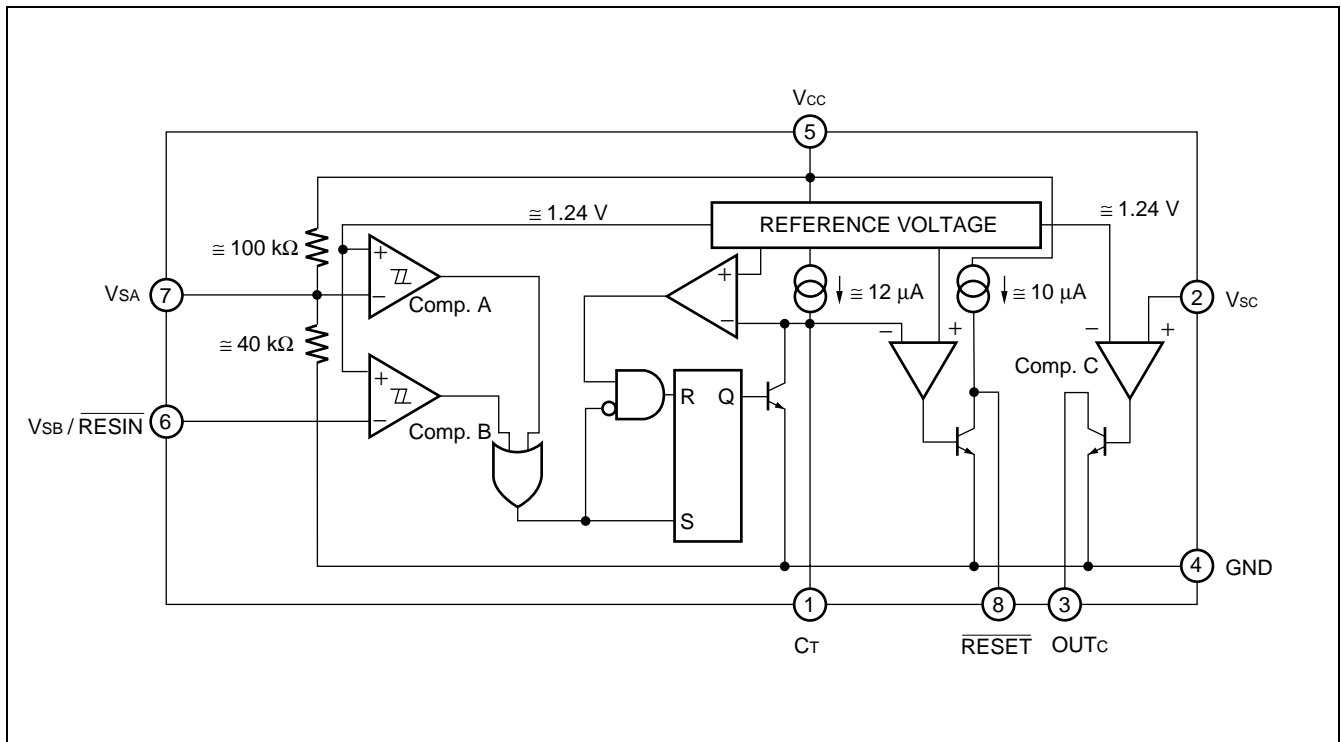

## FUNCTIONAL DESCRIPTIONS

Comparators Comp.A and Comp.B apply a hysteresis to the detected voltage, so that when the voltage at either the  $V_{SA}$  or  $V_{SB}$  pin falls below 1.23 V the  $\overline{\text{RESET}}$  output signal goes to “low” level.

Comp. B may be used to detect any given voltage(Sample Application 3), and can also be used as a forced reset pin (with reset hold time) with TTL input (Sample Application 6).

Note that if Comp.B is not used, the  $V_{SB}$  pin should be connected to the  $V_{CC}$  pin (Sample Application 1).

Instantaneous breaks or drops in the power supply can be detected as abnormal conditions by the MB3771 within a 2  $\mu\text{s}$  interval. However because momentary breaks or drops of this duration do not cause problems in actual systems in some cases, a delayed trigger function can be created by connecting capacitors to the  $V_{SA}$  or  $V_{SB}$  pin (Sample Application 8).

Because the  $\overline{\text{RESET}}$  output has built-in pull-up resistance, there is no need to connect to external pull-up resistance when connected to a high impedance load such as a CMOS logic IC.

Comparator Comp. C is an open-collector output comparator without hysteresis, in which the polarity of input/output characteristics is reversed. Thus Comp. C is useful for over-voltage detection (Sample Application 11) and positive logic  $\overline{\text{RESET}}$  signal output (Sample Application 7), as well as for creating a reference voltage (Sample Application 10).

Note that if Comp. C is not used, the  $V_{SC}$  pin should be connected to the GND pin (Sample Application 1).

## FUNCTION EXPLANATION

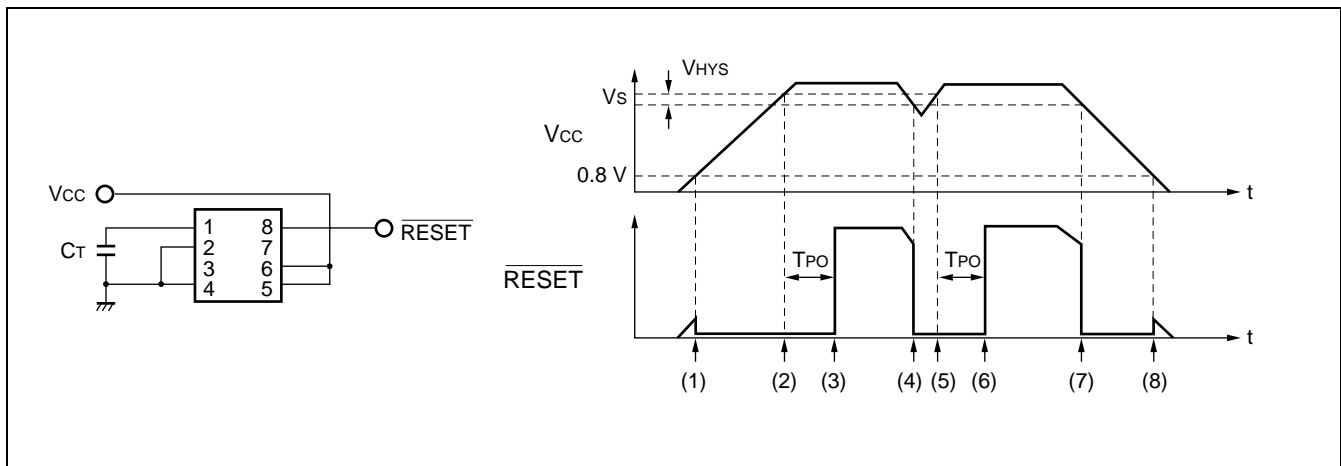

(1) When  $V_{CC}$  rises to about 0.8V,  $\overline{\text{RESET}}$  goes low.

(2) When  $V_{CC}$  reaches  $V_S + V_{HYS}$ ,  $C_T$  then begins charging.  $\overline{\text{RESET}}$  remains low during this time

(3)  $\overline{\text{RESET}}$  goes high when  $C_T$  begins charging.

$$T_{PO} \approx C_T \times 10^5 \text{ (Refer to } C_T \text{ pin capacitance vs. hold time)}$$

(4) When  $V_{CC}$  level drops lower than  $V_S$ , then  $\overline{\text{RESET}}$  goes low and  $C_T$  starts discharging.

(5) When  $V_{CC}$  level reaches  $V_S + V_{HYS}$ , then  $C_T$  starts charging.

In the case of voltage sagging, if the period from the time  $V_{CC}$  goes lower than or equal to  $V_S$  to the time  $V_{CC}$  reaches  $V_S + V_{HYS}$  again, is longer than  $t_{PI}$ , (as specified in the AC Characteristics),  $C_T$  is discharged and charged successively.

(6) After  $T_{PO}$  passes, and  $V_{CC}$  level exceeds  $V_S + V_{HYS}$ , then  $\overline{\text{RESET}}$  goes high.

(7) Same as Point 4.

(8)  $\overline{\text{RESET}}$  remains low until  $V_{CC}$  drops below 0.8V.

## ■ ABSOLUTE MAXIMUM RATINGS

Parameter	Symbol	Rating		Unit
		Min	Max	
Power supply voltage	V <sub>CC</sub>	-0.3	+20	V
Input voltage	V <sub>SA</sub>	-0.3	V <sub>CC</sub> + 0.3 (< +20)	V
	V <sub>SB</sub>	-0.3	+20	V
	V <sub>SC</sub>	-0.3	+20	V
Power dissipation	P <sub>D</sub>	—	200 (T <sub>a</sub> ≤ 85 °C)	mW
Storage temperature	T <sub>stg</sub>	-55	+125	°C

WARNING: Semiconductor devices can be permanently damaged by application of stress (voltage, current, temperature, etc.) in excess of absolute maximum ratings. Do not exceed these ratings.

## ■ RECOMMENDED OPERATING CONDITIONS

Parameter	Symbol	Value		Unit
		Min	Max	
Power supply voltage	V <sub>CC</sub>	3.5	18	V
Output current	I <sub>RESET</sub>	0	20	mA
	I <sub>OUTC</sub>	0	6	mA
Operating ambient temperature	T <sub>op</sub>	-40	+85	°C

WARNING: The recommended operating conditions are required in order to ensure the normal operation of the semiconductor device. All of the device's electrical characteristics are warranted when the device is operated within these ranges.



Always use semiconductor devices within their recommended operating condition ranges. Operation outside these ranges may adversely affect reliability and could result in device failure.

No warranty is made with respect to uses, operating conditions, or combinations not represented on the data sheet. Users considering application outside the listed conditions are advised to contact their FUJITSU representatives beforehand.

## ■ ELECTRICAL CHARACTERISTICS

### 1. DC Characteristics

( $V_{CC} = 5\text{ V}$ ,  $T_a = +25\text{ °C}$ )

Parameter	Symbol	Conditions	Value			Unit
			Min	Typ	Max	
Power supply current	$I_{CC1}$	$V_{SB} = 5\text{ V}$ , $V_{SC} = 0\text{ V}$	—	350	500	$\mu\text{A}$
	$I_{CC2}$	$V_{SB} = 0\text{ V}$ , $V_{SC} = 0\text{ V}$	—	400	600	$\mu\text{A}$
Detection voltage	$V_{SAL}$ (DOWN)	$V_{CC}$ 	4.10	4.20	4.30	V
		$T_a = -40\text{ °C}$ to $+85\text{ °C}$	4.05	4.20	4.35	V
	$V_{SAH}$ (UP)	$V_{CC}$ 	4.20	4.30	4.40	V
		$T_a = -40\text{ °C}$ to $+85\text{ °C}$	4.15	4.30	4.45	V
Hysteresis width	$V_{HYSA}$	—	50	100	150	mV
Detection voltage	$V_{SB}$	$V_{SB}$ 	1.212	1.230	1.248	V
		$T_a = -40\text{ °C}$ to $+85\text{ °C}$	1.200	1.230	1.260	V
Deviation of detection voltage	$\Delta V_{SB}$	$V_{CC} = 3.5\text{ V}$ to $18\text{ V}$	—	3	10	mV
Hysteresis width	$V_{HYSB}$	—	14	28	42	mV
Input current	$I_{IHB}$	$V_{SB} = 5\text{ V}$	—	0	250	nA
	$I_{ILB}$	$V_{SB} = 0\text{ V}$	—	20	250	nA
Output voltage	$V_{OHR}$	$I_{RESET} = -5\text{ }\mu\text{A}$ , $V_{SB} = 5\text{ V}$	4.5	4.9	—	V
	$V_{OLR}$	$I_{RESET} = 3\text{ mA}$ , $V_{SB} = 0\text{ V}$	—	0.28	0.4	V
		$I_{RESET} = 10\text{ mA}$ , $V_{SB} = 0\text{ V}$	—	0.38	0.5	V
Output sink current	$I_{RESET}$	$V_{OLR} = 1.0\text{ V}$ , $V_{SB} = 0\text{ V}$	20	40	—	mA
CT charge current	$I_{CT}$	$V_{SB} = 5\text{ V}$ , $V_{CT} = 0.5\text{ V}$	9	12	16	$\mu\text{A}$
Input current	$I_{IHC}$	$V_{SC} = 5\text{ V}$	—	0	500	nA
	$I_{ILC}$	$V_{SC} = 0\text{ V}$	—	50	500	nA
Detection voltage	$V_{SC}$	—	1.225	1.245	1.265	V
		$T_a = -40\text{ °C}$ to $+85\text{ °C}$	1.205	1.245	1.285	V
Deviation of detection voltage	$\Delta V_{SC}$	$V_{CC} = 3.5\text{ V}$ to $18\text{ V}$	—	3	10	mV
Output leakage current	$I_{OHC}$	$V_{OHC} = 18\text{ V}$	—	0	1	$\mu\text{A}$
Output voltage	$V_{OLC}$	$I_{OUTC} = 4\text{ mA}$ , $V_{SC} = 5\text{ V}$	—	0.15	0.4	V
Output sink current	$I_{OUTC}$	$V_{OLC} = 1.0\text{ V}$ , $V_{SC} = 5\text{ V}$	6	15	—	mA
Reset operation minimum supply voltage	$V_{CCL}$	$V_{OLR} = 0.4\text{ V}$ , $I_{RESET} = 200\text{ }\mu\text{A}$	—	0.8	1.2	V

## 2. AC Characteristics

( $V_{CC} = 5\text{ V}$ ,  $T_a = +25\text{ °C}$ ,  $C_T = 0.01\text{ }\mu\text{F}$ )

Parameter	Symbol	Conditions	Value			Unit
			Min	Typ	Max	
$V_{SA}$ , $V_{SB}$ input pulse width	$t_{PI}$	—	5.0	—	—	$\mu\text{s}$
Reset hold time	$t_{PO}$	—	0.5	1.0	1.5	ms
$\overline{\text{RESET}}$ rise time	$t_r$	$R_L = 2.2\text{ k}\Omega$ , $C_L = 100\text{ pF}$	—	1.0	1.5	$\mu\text{s}$
$\overline{\text{RESET}}$ fall time	$t_f$		—	0.1	0.5	$\mu\text{s}$
Propagation delay time	$t_{PD}^{*1}$	—	—	2	10	$\mu\text{s}$
	$t_{PHL}^{*2}$	$R_L = 2.2\text{ k}\Omega$ , $C_L = 100\text{ pF}$	—	0.5	—	$\mu\text{s}$
	$t_{PLH}^{*2}$		—	1.0	—	$\mu\text{s}$

\*1: In case of  $V_{SB}$  termination.

\*2: In case of  $V_{SC}$  termination.

## ■ APPLICATION CIRCUIT

### 1. 5V Power Supply Monitor

Monitored by  $V_{SA}$ . Detection threshold voltage is  $V_{SAL}$  and  $V_{SAH}$

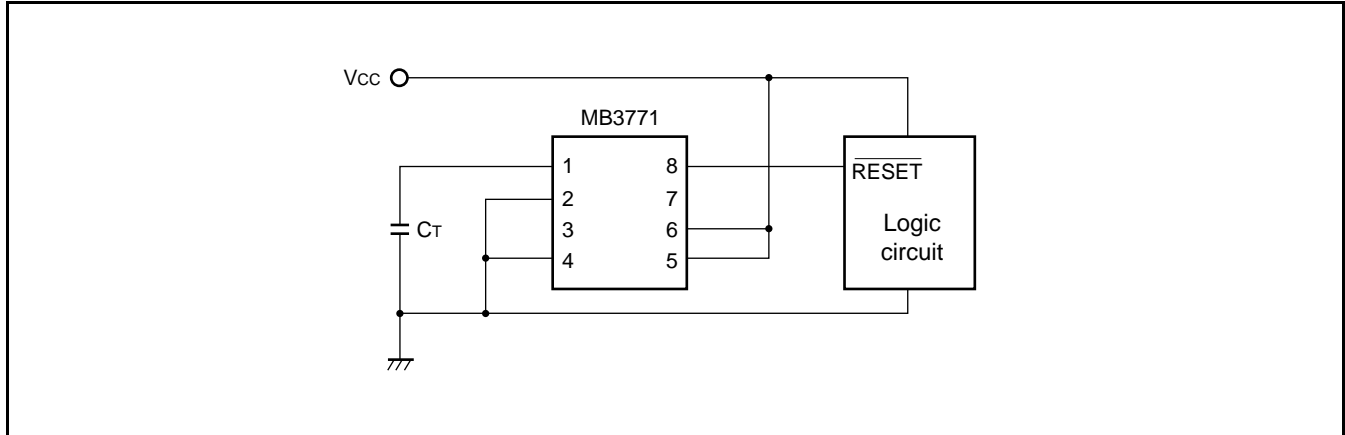

### 2. 5V Power Supply Voltage Monitor (Externally Fine-Tuned Type)

The  $V_{SA}$  detection voltage can be adjusted externally.

Resistance  $R_1$  and  $R_2$  are set sufficiently lower than the IC internal partial voltage resistance, so that the detection voltage can be set using the ratio between resistance  $R_1$  and  $R_2$ . (See the table below).

- $R_1, R_2$  calculation formula (when  $R_1 \ll 100 \text{ k}\Omega$ ,  $R_2 \ll 40 \text{ k}\Omega$ )

$$V_{SAL} \doteq (R_1 + R_2) \times V_{SB} / R_2 \text{ [V]}, \quad V_{SAH} \doteq (R_1 + R_2) \times (V_{SB} + V_{HYSB}) / R_2 \text{ [V]}$$

$R_1$ (k $\Omega$ )	$R_2$ (k $\Omega$ )	Detection voltage : $V_{SAL}$ (V)	Detection voltage : $V_{SAH}$ (V)
10	3.9	4.37	4.47
9.1	3.9	4.11	4.20

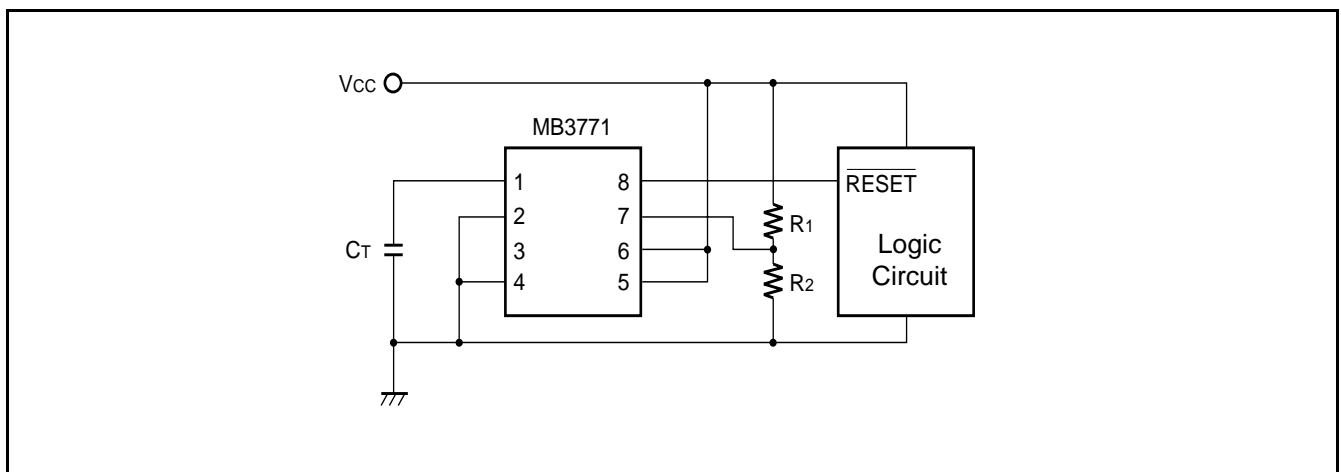

## 3. Arbitrary Voltage Supply Monitor

### (1) Case: $V_{CC} \leq 18\text{ V}$

- Detection Voltage can be set by  $R_1$  and  $R_2$ .  
Detection Voltage =  $(R_1 + R_2) \times V_{SB}/R_2$
- Connect Pin 7 to  $V_{CC}$  when  $V_{CC}$  less than 4.45 V.
- Pin 7 can be opened when  $V_{CC}$  greater than 4.45 V  
Power Dissipation can be reduced.

Note : Hysteresis of 28 mV at  $V_{SB}$  at termination is available.  
Hysteresis width dose not depend on  $(R_1 + R_2)$ .

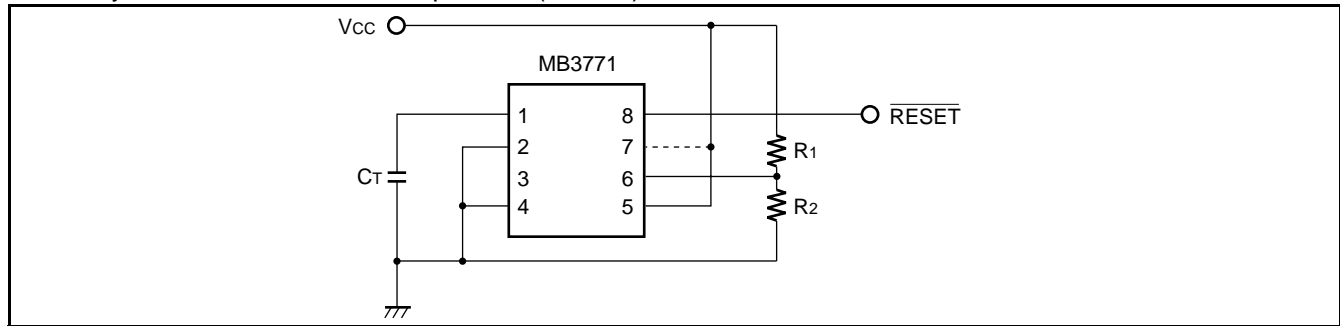

### (2) Monitoring $V_{CC} > 18\text{ V}$

- Detection Voltage can be set by  $R_1$  and  $R_2$   
Detection Voltage =  $(R_1 + R_2) \times V_{SB}/R_2$
- The  $\overline{\text{RESET}}$  signal output is  $\neq 0\text{ V}$  (low level) and  $\neq 5\text{ V}$  (high level).  $V_{CC}$  voltage cannot be output.  
Do not pull up  $\overline{\text{RESET}}$  to  $V_{CC}$ .
- Changing the resistance ratio between  $R_4$  and  $R_5$  changes the constant voltage output, thereby changing the voltage of the high level  $\overline{\text{RESET}}$  output. Note that the constant voltage output should not exceed 18 V.
- The 5 V output can be used as a power supply for control circuits with low current consumption.
- In setting the  $R_3$  resistance level, caution should be given to the power consumption in the resistor. The table below lists sample resistance values for reference (using  $1/4\ \Omega$  resistance).

$V_{CC}$ (V)	Detection voltage (V)	$\overline{\text{RESET}}$ Output min. power supply voltage (V)	$R_1$ (M $\Omega$ )	$R_2$ (k $\Omega$ )	$R_3$ (k $\Omega$ )	Output Current (mA)
140	100	6.7	1.6	20	110	< 0.2
100	81	3.8	1.3	20	56	< 0.5
40	33	1.4	0.51	20	11	< 1.6

- Values are actual measured values (using  $I_{OUTC} = 100\ \mu\text{A}$ ,  $V_{OLC} = 0.4\text{ V}$ ). Lowering the resistance value of  $R_3$  reduces the minimum supply voltage of the  $\overline{\text{RESET}}$  output, but requires resistance with higher allowable loss.

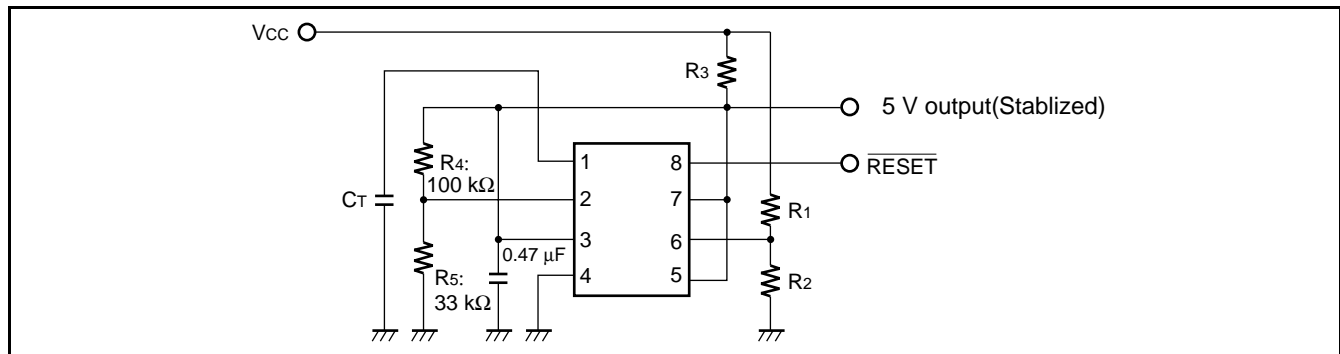



#### 4. 5 V and 12 V Power Supply Monitor (2 types of power supply monitor $V_{CC1} = 5\text{ V}$ , $V_{CC2} = 12\text{ V}$ )

- 5 V is monitored by  $V_{SA}$ . Detection voltage is about 4.2 V
- 12 V is monitored by  $V_{SB}$ . When  $R_1 = 390\text{ k}\Omega$  and  $R_2 = 62\text{ k}\Omega$ , Detection voltage is about 9.0 V. Generally the detection voltage is determined by the following equation.

$$\text{Detection Voltage} = (R_1 + R_2) \times V_{SB} / R_2$$

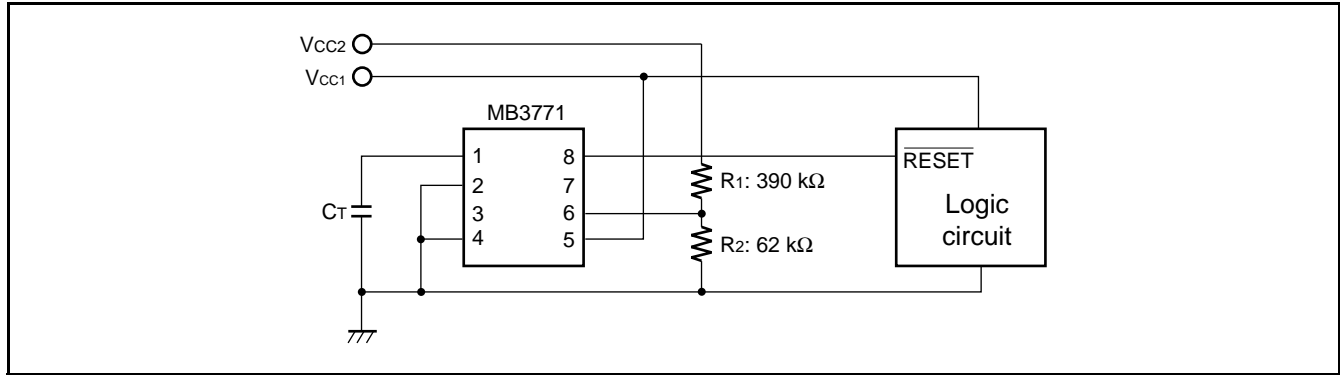

#### 5. 5 V and 12 V Power Supply Monitor ( $\overline{\text{RESET}}$ signal is generated by 5 V, $V_{CC1} = 5\text{ V}$ , $V_{CC2} = 12\text{ V}$ )

- 5 V is monitored by  $V_{SA}$ , and generates  $\overline{\text{RESET}}$  signal when  $V_{SA}$  detects voltage sagging.
- 12 V is monitored by  $V_{SC}$ , and generates its detection signal at  $\text{OUT}_C$ .
- The detection voltage of 12 V monitoring and its hysteresis is determined by the following equations.

$$\text{Detection voltage} = \frac{R_1 + R_2 + R_3}{R_2 + R_3} \times V_{SC} \quad (8.95\text{ V in the circuit above})$$

$$\text{Hysteresis width} = \frac{R_1 (R_3 - R_3 // R_4)}{(R_2 + R_3) (R_2 + R_3 // R_4)} \times V_{SC} \quad (200\text{ mV in the circuit above})$$

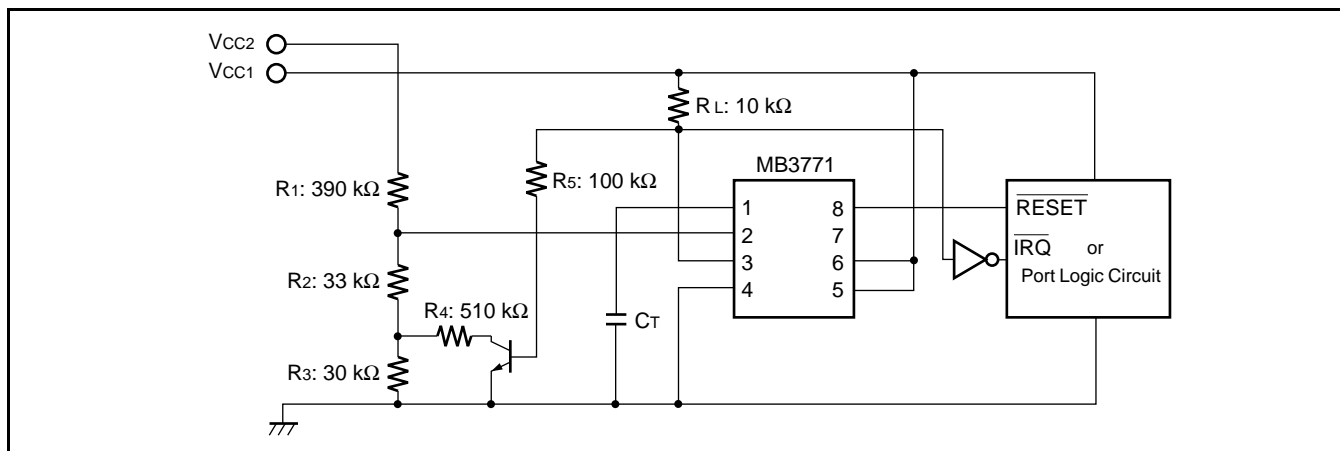

## 6. 5 V Power Supply Monitor with forced $\overline{\text{RESET}}$ input ( $V_{CC} = 5 \text{ V}$ )

$\overline{\text{RESIN}}$  is an TTL compatible input.

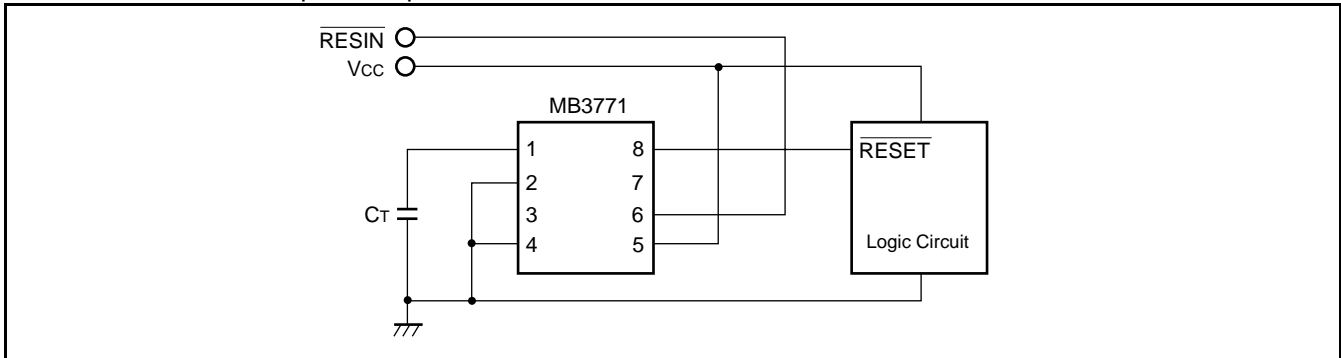

## 7. 5 V Power Supply Monitor with Non-inverted $\overline{\text{RESET}}$

In this case, Comparator C is used to invert  $\overline{\text{RESET}}$  signal. OUTC is an open-collector output.

RL is used as a pull-up resistor.

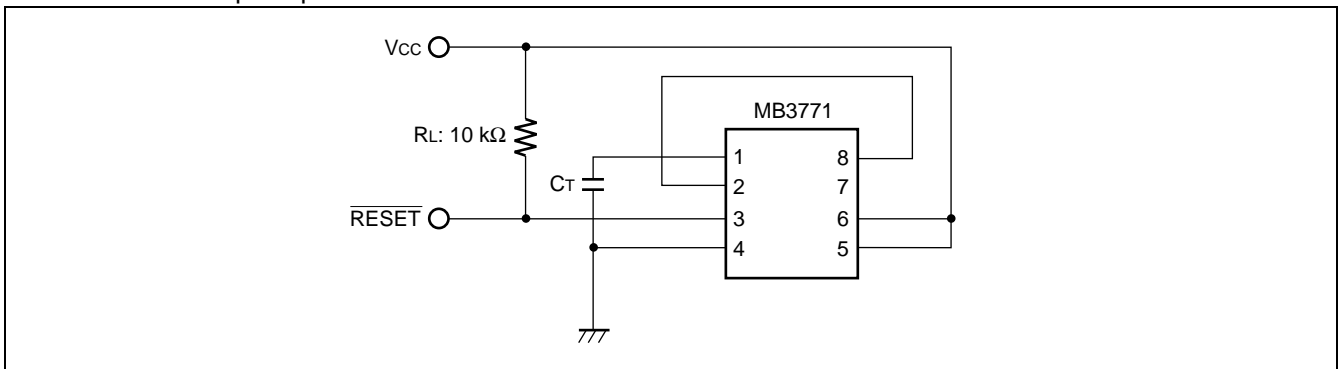

## 8. Supply Voltage Monitoring with Delayed Trigger

When the voltage shown in the diagram below is applied at  $V_{CC}$ , the minimum value of the input pulse width is increased to  $40 \mu\text{s}$  (when  $C_1 = 1000 \text{ pF}$ ).

The formula for calculating the minimum value of the input pulse width [ $T_{PI}$ ] is:

$$T_{PI} [\mu\text{s}] \doteq 4 \times 10^{-2} \times C_1 [\text{pF}]$$

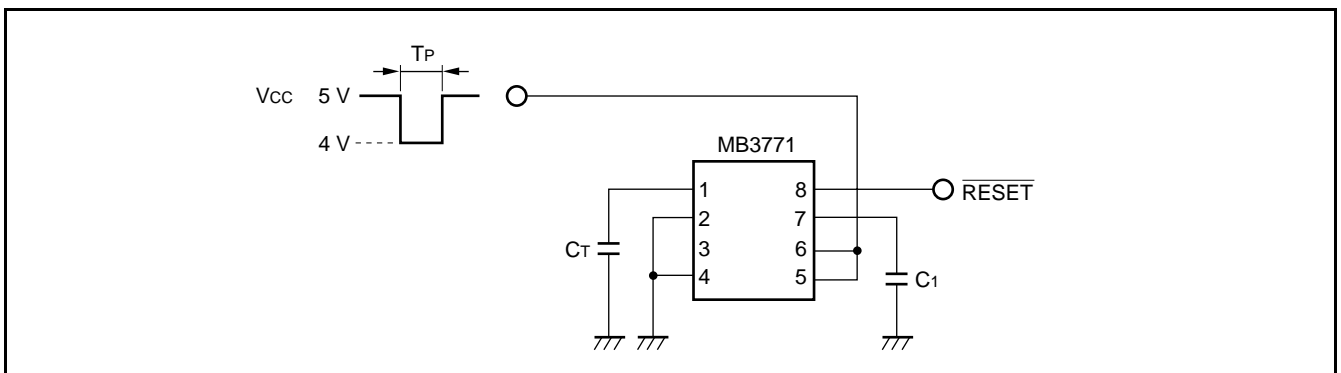

## 9. Dual (Positive/Negative) Power Supply Voltage Monitoring ( $V_{CC} = 5\text{ V}$ , $V_{EE} = \text{Negative Power Supply}$ )

Monitors a 5 V and a negative (any given level) power supply.  $R_1$ ,  $R_2$ , and  $R_3$  should be the same value.

$$\text{Detection Voltage} = V_{SB} - V_{SB} \times R_4/R_3$$

Example if  $V_{EE} = -5\text{ V}$ ,  $R_4 = 91\text{ k}\Omega$

Then the detected voltage =  $-4.37\text{ V}$

In cases where  $V_{EE}$  may be output when  $V_{CC}$  is not output, it is necessary to use a Schottky barrier diode (SBD).

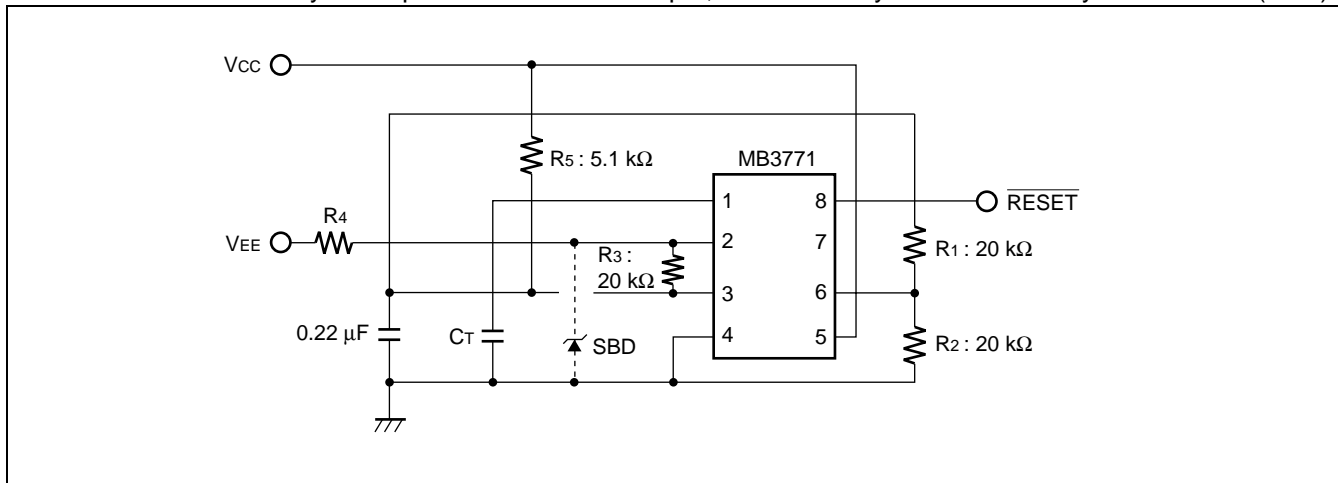

## 10. Reference Voltage Generation and Voltage Sagging Detection

### (1) 9V Reference Voltage Generation and 5V/9V Monitoring

$$\text{Detection Voltage} = 7.2\text{ V}$$

In the above examples, the output voltage and the detection voltage are determined by the following equations:

$$\text{Detection Voltage} = (R_1 + R_2) \times V_{SB}/R_2$$

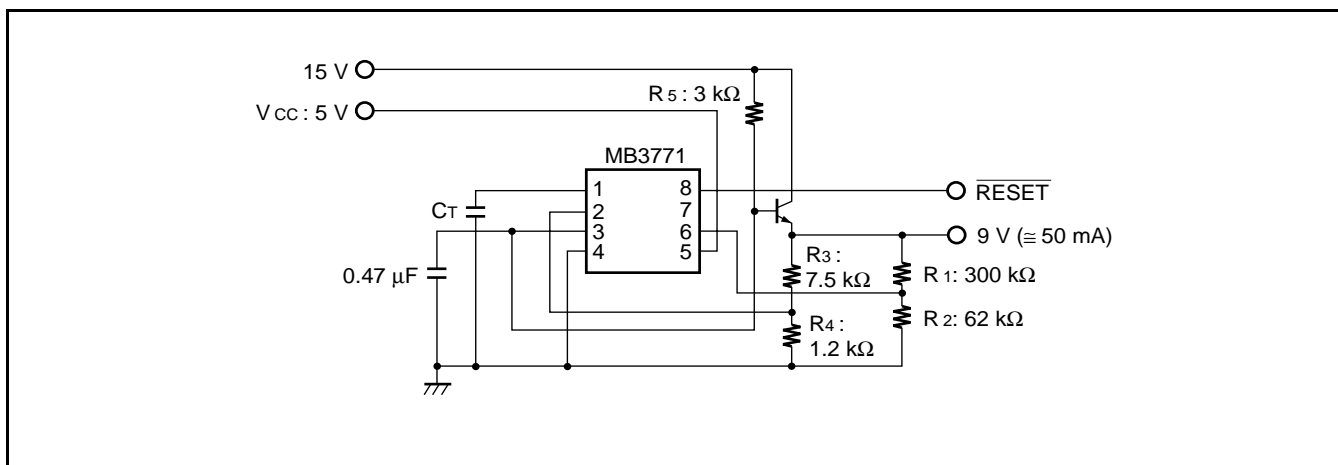

# MB3771

## (2) 5 V Reference Voltage Generation and 5V Monitoring (No.1)

Detection Voltage = 4.2 V

In the above examples, the output voltage and the detection voltage are determined by the following equations:

$$\text{Output Voltage} = (R_3 + R_4) \times V_{sc}/R_4$$

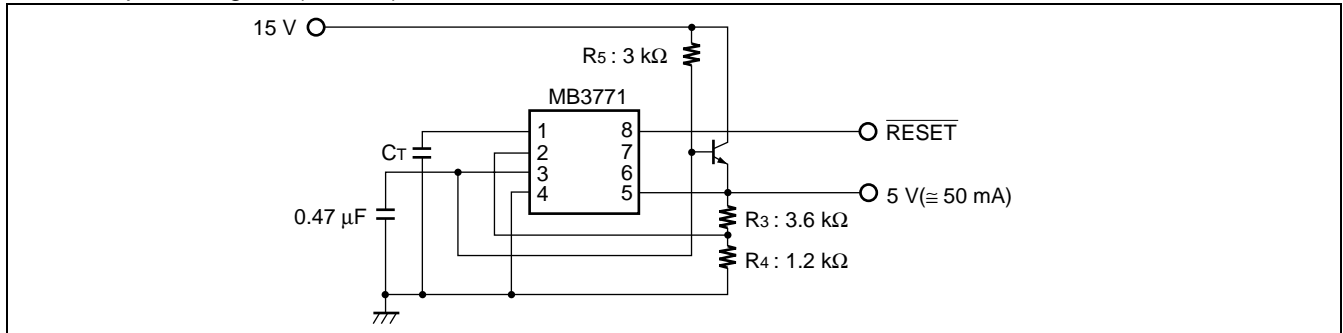

## (3) 5 V Reference Voltage Generation and 5 V Monitoring (No. 2)

The value of  $R_1$  should be calculated from the current consumption of the MB3771, the current flowing at  $R_2$  and  $R_3$ , and the 5 V output current. The table below provides sample resistance values for reference.

$V_{cc}$ (V)	$R_1$ (k $\Omega$ )	Output Current (mA)
40	11	< 1.6
24	6.2	< 1.4
15	4.7	< 0.6

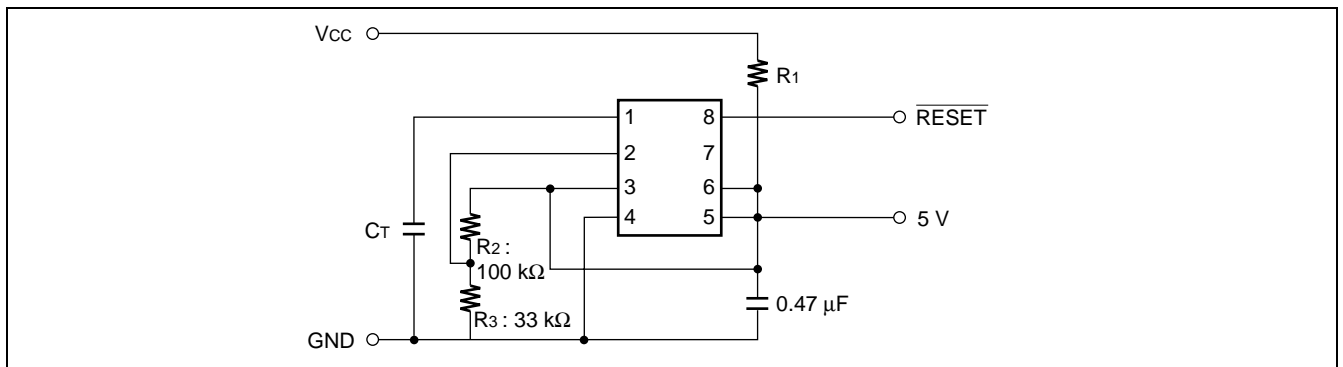

## (4) 1.245 V Reference Voltage Generation and 5 V Monitoring

Resistor  $R_1$  determines Reference current. Using 1.2 k $\Omega$  as  $R_1$ , reference current is about 2 mA.

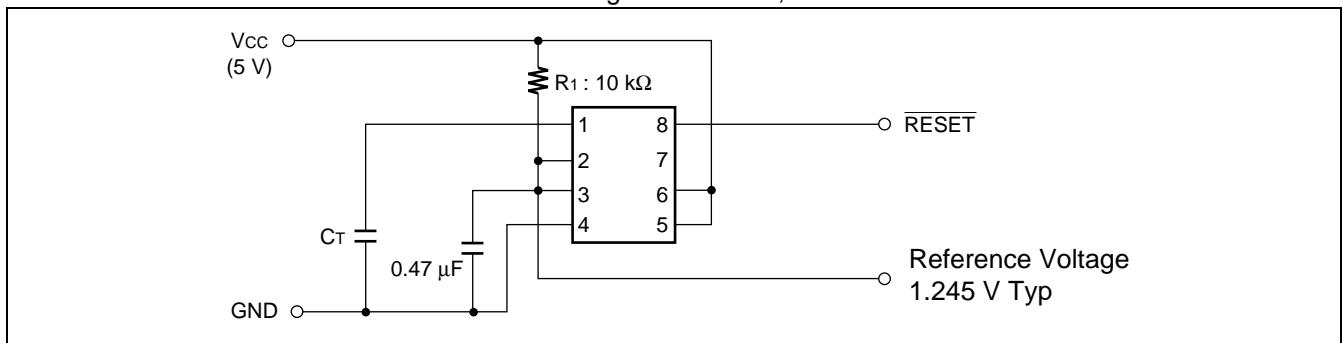

## 11. Low Voltage and Over Voltage Detection ( $V_{CC} = 5\text{ V}$ )

$V_{SH}$  has no hysteresis. When over voltage is detected,  $\overline{\text{RESET}}$  is held in the constant time as well as when low voltage is detected.

$$V_{SL} = (R_1 + R_2) \times V_{SB}/R_2$$

$$V_{SH} = (R_3 + R_4) \times V_{SC}/R_4$$

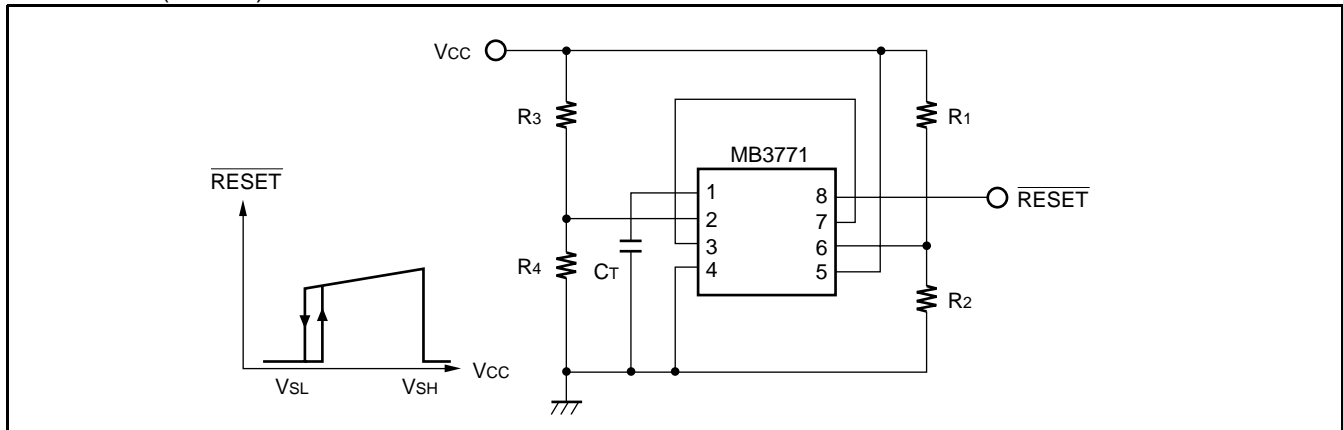

## 12. Detection of Abnormal State of Power Supply System ( $V_{CC} = 5\text{ V}$ )

- This Example circuit detects abnormal low/over voltage of power supply voltage and is indicated by LED indicator. LED is reset by the CLEAR key.
- The detection levels of low/over voltages are determined by  $V_{SA}$ , and  $R_1$  and  $R_2$  respectively.

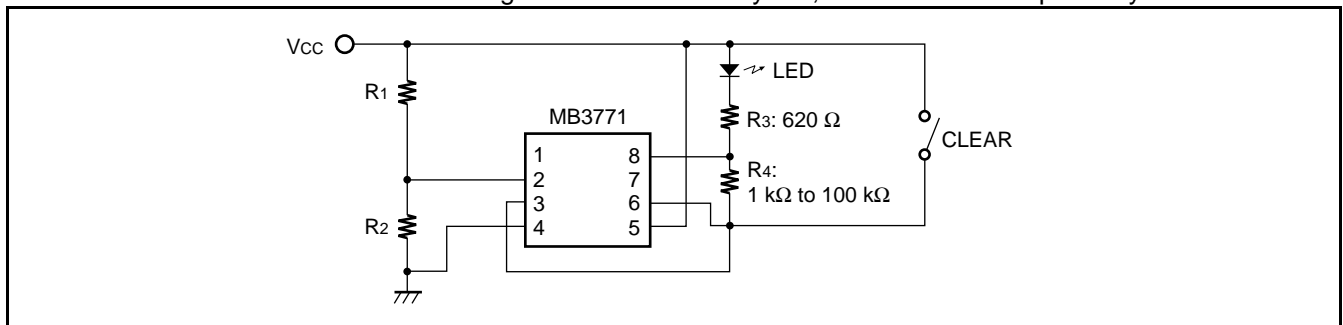

## 13. Back-up Power Supply System (V<sub>CC</sub> = 5 V)

- Use CMOS Logic and connect V<sub>DD</sub> of CMOS logic with V<sub>CCO</sub>.
- The back-up battery works after CS goes high as V<sub>2</sub> < V<sub>1</sub>.
- During t<sub>P0</sub>, memory access is prohibited.
- CS's threshold voltage V<sub>1</sub> is determined by the following equation:

$$V_1 = V_F + (R_1 + R_2 + R_3) \times V_{SB}/R_3$$

When V<sub>1</sub> is 4.45 V or less, connect 7 pin with V<sub>CC</sub>.

When V<sub>1</sub> is 4.45 V or more, 7 pin can be used to open.

- The voltage to change V<sub>2</sub> is provided as the following equation:

$$V_2 = V_F + (R_1 + R_2 + R_3) \times V_{SC}/(R_2 + R_3)$$

However, please set V<sub>2</sub> to 3.5 V or more.

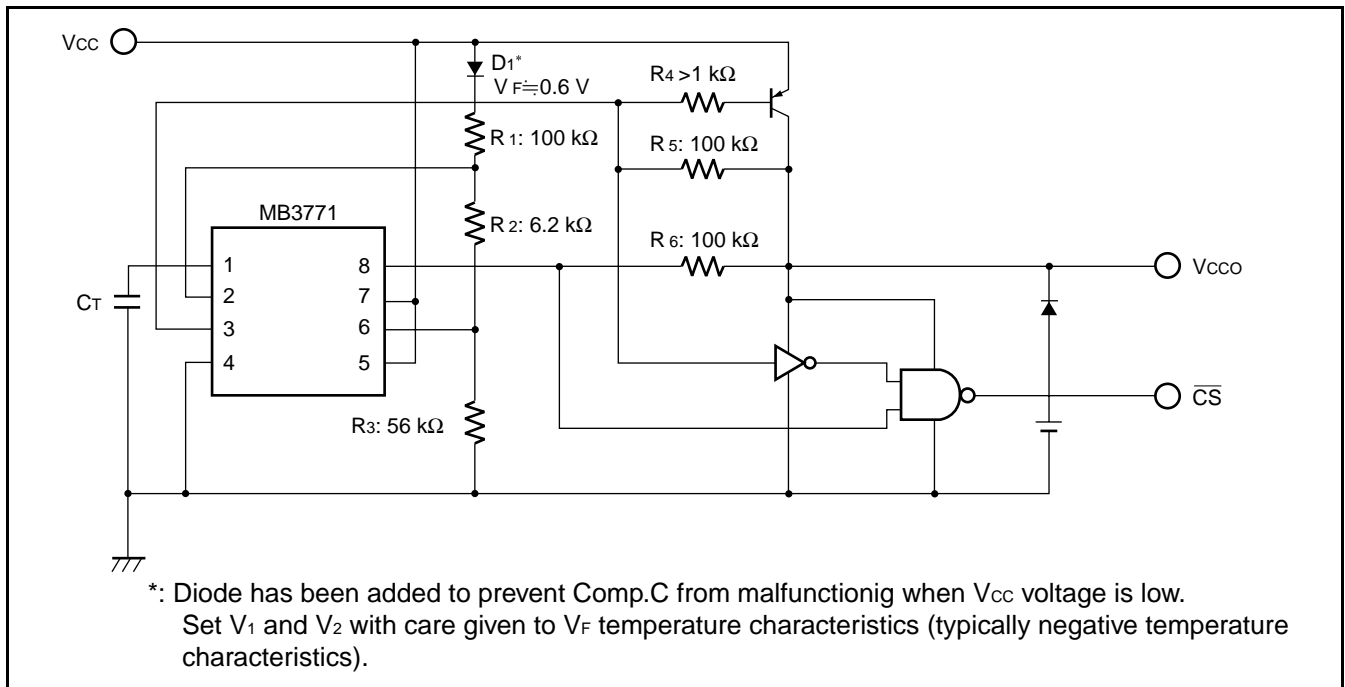
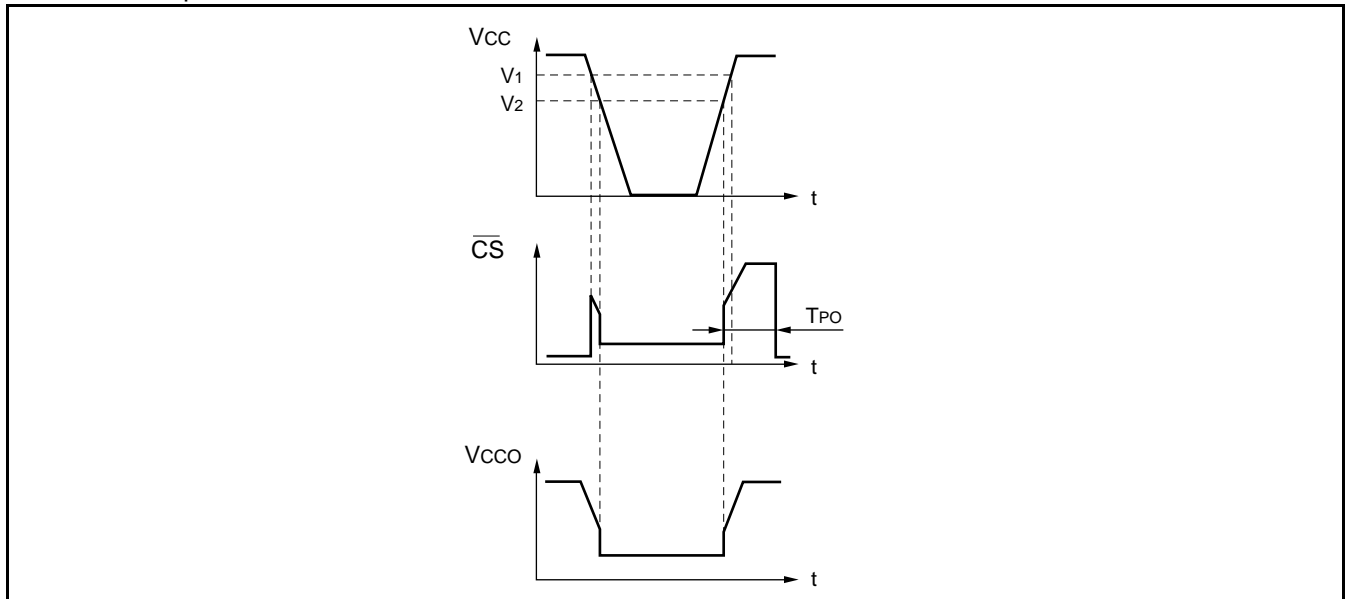

\*: Diode has been added to prevent Comp.C from malfunctioning when V<sub>CC</sub> voltage is low.  
Set V<sub>1</sub> and V<sub>2</sub> with care given to V<sub>F</sub> temperature characteristics (typically negative temperature characteristics).

## TYPICAL CHARACTERISTICS

Power supply current vs. power supply voltage

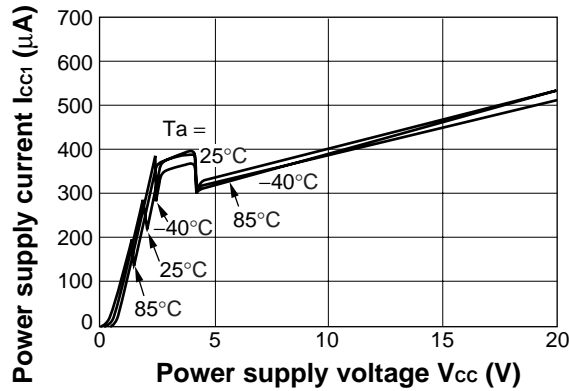

Detection voltage ( $V_{sc}$ ) vs. ambient temperature

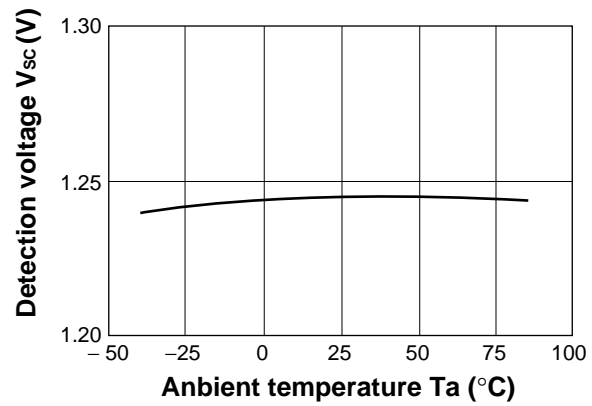

Power supply current vs. power supply voltage

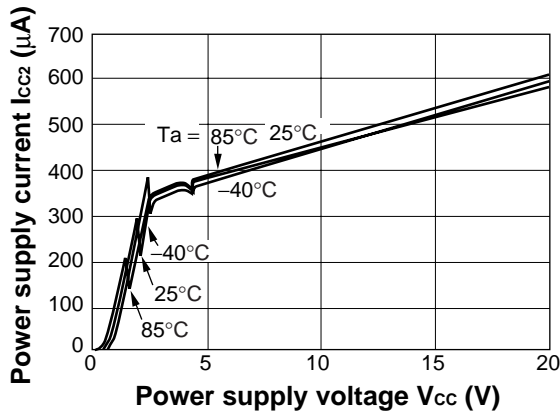

Detection voltage ( $V_{sb}$ ) vs. ambient temperature

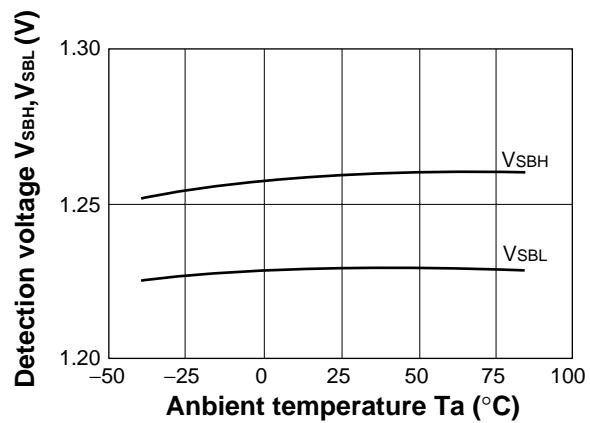

Output ( $\overline{\text{RESET}}$ ) voltage vs. power supply voltage

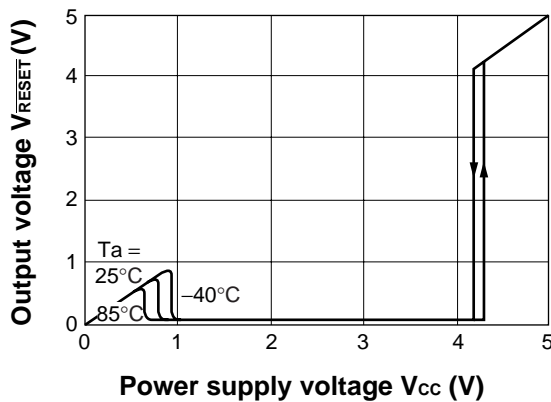

Detection voltage ( $V_{sa}$ ) vs. ambient temperature

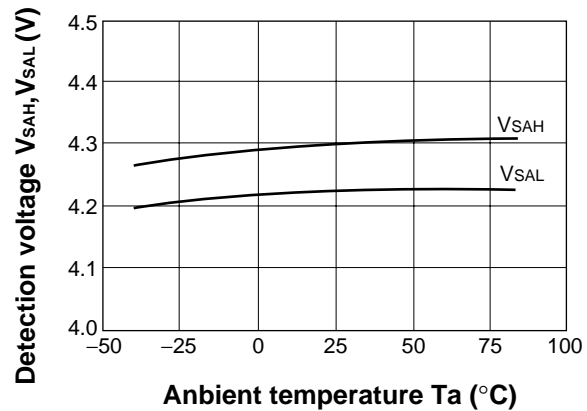

(Continued)

(Continued)

Detection voltage ( $V_{SB}$ ,  $V_{SC}$ ) vs. Power supply voltage

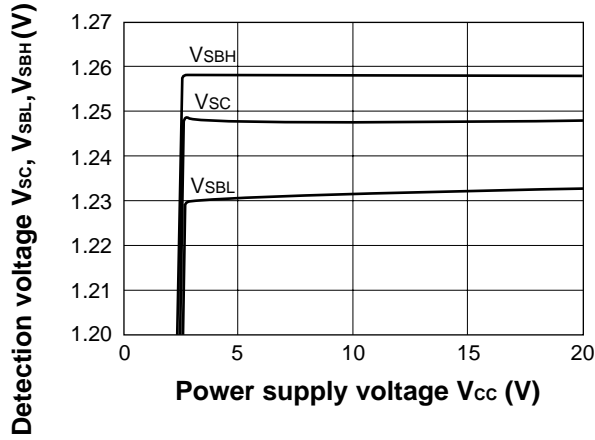

Reset voltage ( $\overline{RESET}$ ) vs. output current

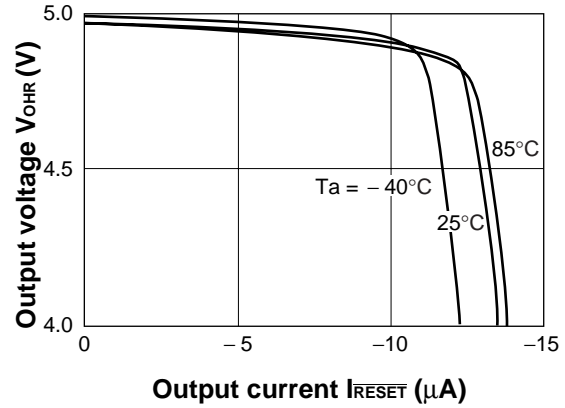

Reset hold time vs. power supply voltage ( $C_T = 0.01 \mu F$ )

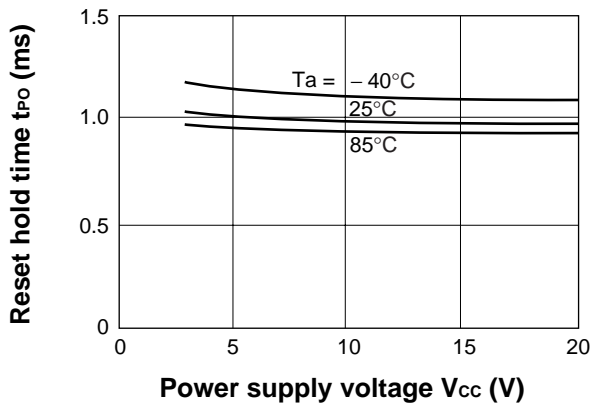

Output ( $\overline{RESET}$ ) voltage vs. output current

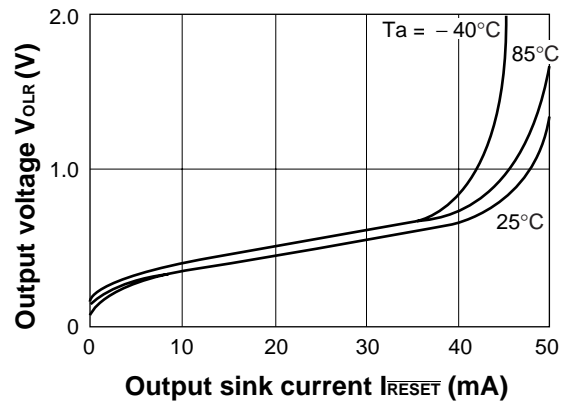

$C_T$  pin capacitance vs. reset hold time

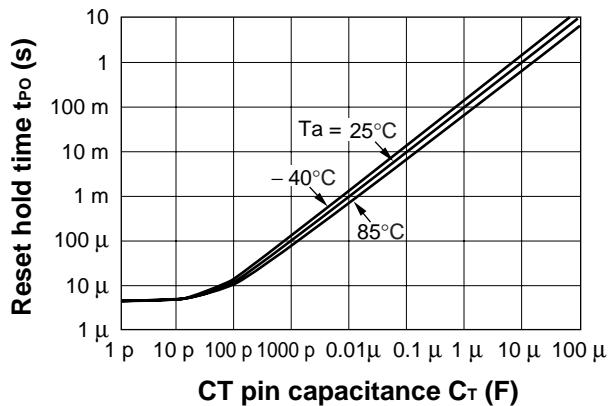

Output voltage ( $OUT_c$ ) vs. output current

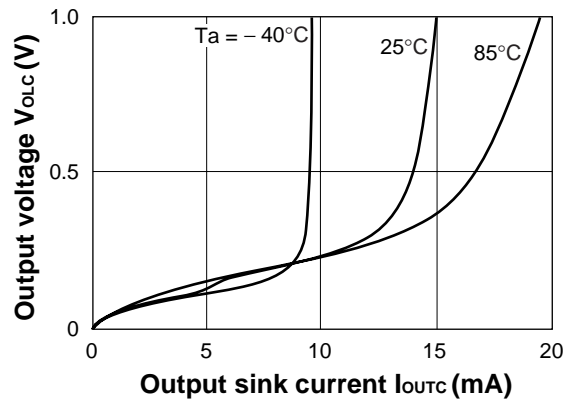



## ■ NOTES ON USE

- Take account of common impedance when designing the earth line on a printed wiring board.
- Take measures against static electricity.
  - For semiconductors, use antistatic or conductive containers.
  - When storing or carrying a printed circuit board after chip mounting, put it in a conductive bag or container.
  - The work table, tools and measuring instruments must be grounded.
  - The worker must put on a grounding device containing 250 k $\Omega$  to 1 M $\Omega$  resistors in series.
- Do not apply a negative voltage
  - Applying a negative voltage of  $-0.3$  V or less to an LSI may generate a parasitic transistor, resulting in malfunction.

## ■ ORDERING INFORMATION

Part number	Package	Remarks
MB3771P	8-pin Plastic DIP (DIP-8P-M01)	
MB3771PS	8-pin Plastic SIP (SIP-8P-M03)	
MB3771PF	8-pin Plastic SOP (FPT-8P-M01)	

# MB3771

## ■ PACKAGE DIMENSIONS

8-pin Plastic DIP  
(DIP-8P-M01)

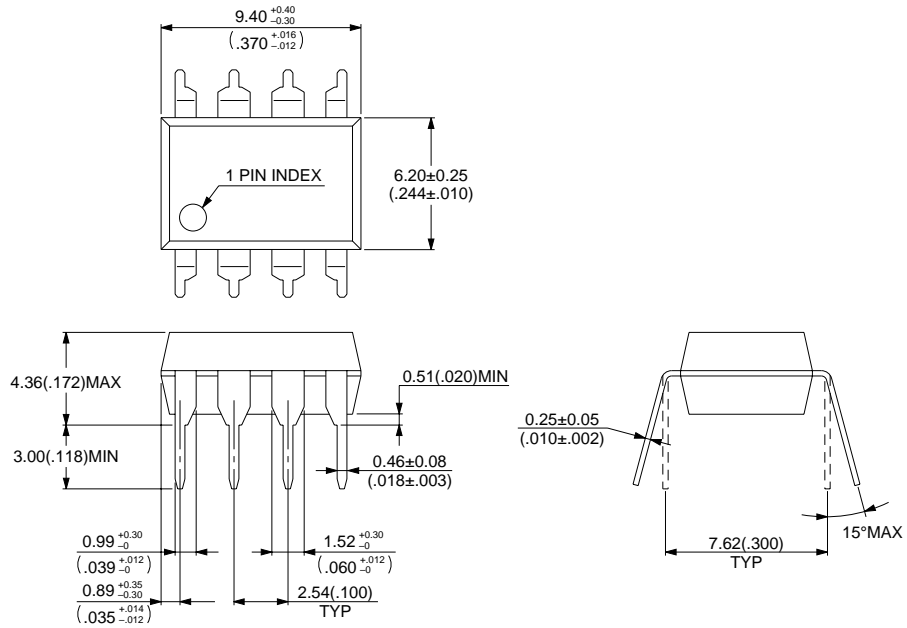

© 1994 FUJITSU LIMITED D08006S-2C-3

Dimensions in mm (inches) .  
Note : The values in parentheses are reference values.

(Continued)

(Continued)

## 8-pin Plastic SIP (SIP-8P-M03)

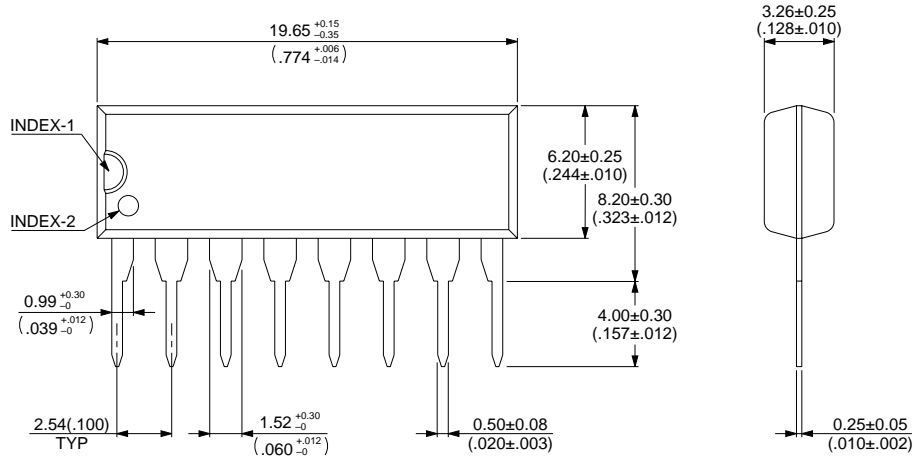

© 1994 FUJITSU LIMITED S08010S-3C-2

Dimensions in mm (inches) .

Note : The values in parentheses are reference values.

(Continued)

# MB3771

(Continued)

8-pin Plastic SOP  
(FPT-8P-M01)

- Note 1) \*1 : These dimensions include resin protrusion.
- Note 2) \*2 : These dimensions do not include resin protrusion.
- Note 3) Pins width and pins thickness include plating thickness.
- Note 4) Pins width do not include tie bar cutting remainder.

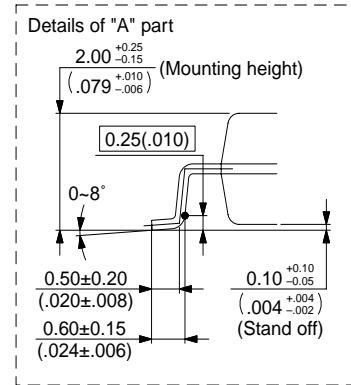
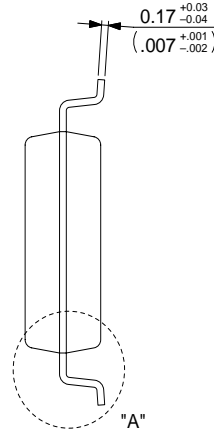
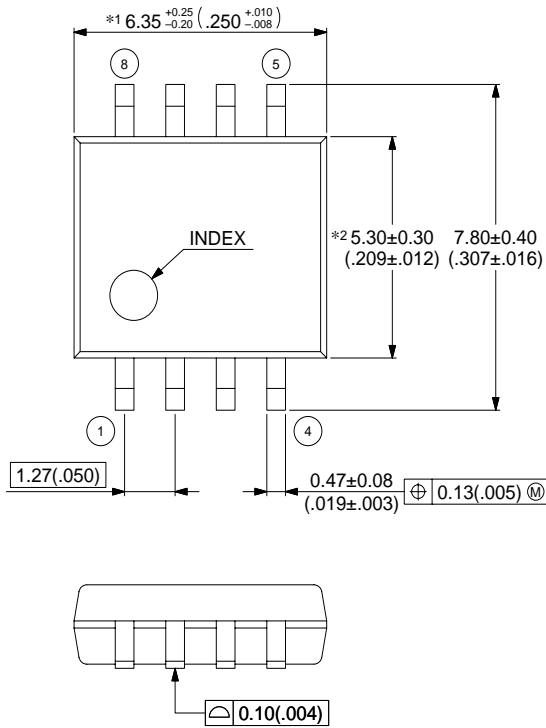

© 2002 FUJITSU LIMITED F08002S-c-6-7

Dimensions in mm (inches) .  
Note : The values in parentheses are reference values.

## FUJITSU LIMITED

All Rights Reserved.

The contents of this document are subject to change without notice. Customers are advised to consult with FUJITSU sales representatives before ordering.

The information, such as descriptions of function and application circuit examples, in this document are presented solely for the purpose of reference to show examples of operations and uses of Fujitsu semiconductor device; Fujitsu does not warrant proper operation of the device with respect to use based on such information. When you develop equipment incorporating the device based on such information, you must assume any responsibility arising out of such use of the information. Fujitsu assumes no liability for any damages whatsoever arising out of the use of the information.

Any information in this document, including descriptions of function and schematic diagrams, shall not be construed as license of the use or exercise of any intellectual property right, such as patent right or copyright, or any other right of Fujitsu or any third party or does Fujitsu warrant non-infringement of any third-party's intellectual property right or other right by using such information. Fujitsu assumes no liability for any infringement of the intellectual property rights or other rights of third parties which would result from the use of information contained herein.

The products described in this document are designed, developed and manufactured as contemplated for general use, including without limitation, ordinary industrial use, general office use, personal use, and household use, but are not designed, developed and manufactured as contemplated (1) for use accompanying fatal risks or dangers that, unless extremely high safety is secured, could have a serious effect to the public, and could lead directly to death, personal injury, severe physical damage or other loss (i.e., nuclear reaction control in nuclear facility, aircraft flight control, air traffic control, mass transport control, medical life support system, missile launch control in weapon system), or (2) for use requiring extremely high reliability (i.e., submersible repeater and artificial satellite).

Please note that Fujitsu will not be liable against you and/or any third party for any claims or damages arising in connection with above-mentioned uses of the products.

Any semiconductor devices have an inherent chance of failure. You must protect against injury, damage or loss from such failures by incorporating safety design measures into your facility and equipment such as redundancy, fire protection, and prevention of over-current levels and other abnormal operating conditions.

If any products described in this document represent goods or technologies subject to certain restrictions on export under the Foreign Exchange and Foreign Trade Law of Japan, the prior authorization by Japanese government will be required for export of those products from Japan.

F0308

© FUJITSU LIMITED Printed in Japan