

## 8M-BIT MASK ROM (8/16 BIT OUTPUT)

### FEATURES

- Bit organization
  - 1M x 8 (byte mode)
  - 512K x 16 (word mode)
- Fast access time
  - Random access: 100ns (max.)
- Current
  - Operating: 60mA
  - Standby: 50uA
- Supply voltage
  - 5V±10%
- Package
  - 44 pin SOP (500mil)
  - 42 pin PDIP (600mil)
  - 48 pin TSOP (20mm x 12mm)

### PIN CONFIGURATION

#### 42 PDIP

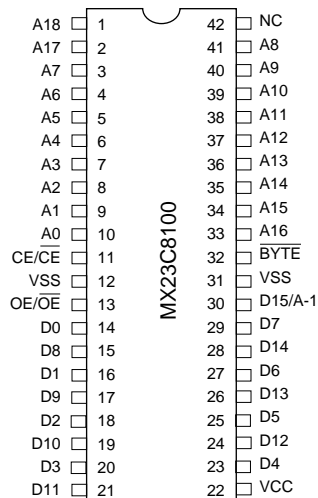

#### 44 SOP

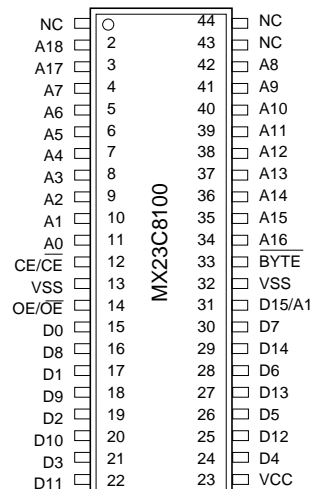

### ORDER INFORMATION

Part No.	Access Time	Package
MX23C8100PC-10	100ns	42 pin PDIP
MX23C8100PC-12	120ns	42 pin PDIP
MX23C8100PC-15	150ns	42 pin PDIP
MX23C8100MC-10	100ns	44 pin SOP
MX23C8100MC-12	120ns	44 pin SOP
MX23C8100MC-15	150ns	44 pin SOP
MX23C8100TC-10	100ns	48 pin TSOP
MX23C8100TC-12	120ns	48 pin TSOP
MX23C8100TC-15	150ns	48 pin TSOP

Note: 40-TSOP and 48-RTSOP support word mode only, not for byte mode.

### PIN DESCRIPTION

Symbol	Pin Function
A0~A18	Address Inputs
D0~D14	Data Outputs
D15/A-1	D15 (Word Mode)/ LSB Address (Byte Mode)
CE/CE	Chip Enable Input
OE/OE	Output Enable Input
Byte	Word/ Byte Mode Selection
VCC	Power Supply Pin
VSS	Ground Pin
NC	No Connection

#### 48 TSOP (for word mode only)

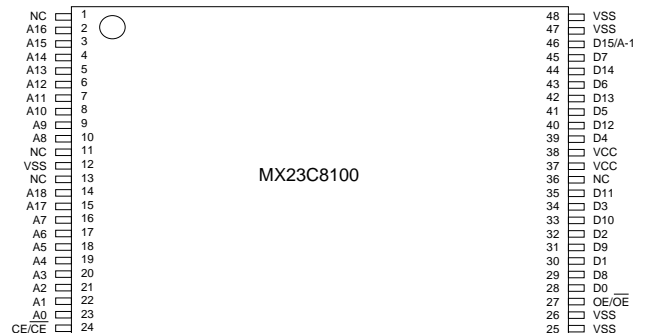

**MODE SELECTION**

$\overline{\text{CE}}/\overline{\text{CE}}$	$\overline{\text{OE}}/\overline{\text{OE}}$	Byte	D15/A-1	D0~D7	D8~D15	Mode	Power
L/H	X	X	X	High Z	High Z	-	Stand-by
H/L	L/H	X	X	High Z	High Z	-	Active
H/L	H/L	H	Output	D0~D7	D8~D15	Word	Active
H/L	H/L	L	Input	D0~D7	High Z	Byte	Active

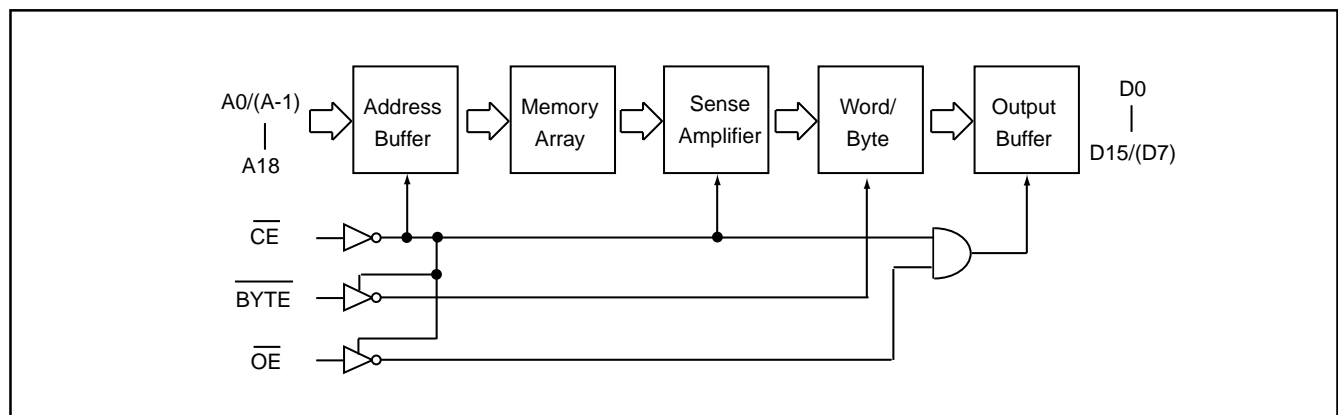
**BLOCK DIAGRAM**

**ABSOLUTE MAXIMUM RATINGS**

Item	Symbol	Ratings
Voltage on any Pin Relative to VSS	VCC	-0.5V to 7.0V
Ambient Operating Temperature	Topr	0°C to 70°C
Storage Temperature	Tstg	-65°C to 125°C

Note: minimum DC voltage on input or I/O pins is -0.5V. During voltage transitions, inputs may undershoot VSS to -2.0V for periods of up to 20ns. Maximum DC voltage on input or I/O pins is VCC+0.5V. During voltage transitions, input may overshoot VCC to VCC+2.0V for periods of up to 20ns.

**DC CHARACTERISTICS** ( $T_a = 0^\circ\text{C} \sim 70^\circ\text{C}$ ,  $V_{CC} = 5V \pm 10\%$ )

Item	Symbol	MIN.	MAX.	Conditions
Output High Voltage	VOH	2.4V	-	IOH = -1.0mA
Output Low Voltage	VOL	-	0.4V	IOL = 2.1mA
Input High Voltage	VIH	2.2V	VCC+0.3V	
Input Low Voltage	VIL	-0.3V	0.8V	
Input Leakage Current	ILI	-	10uA	0V, VCC
Output Leakage Current	ILO	-	10uA	0V, VCC
Operating Current	ICC1	-	60mA	tRC=100ns, all output open
Standby Current (TTL)	ISTB1	-	1mA	$\overline{CE} = V_{IH}$
Standby Current (CMOS)	ISTB2	-	50uA	$\overline{CE} > V_{CC} - 0.2V$
Input Capacitance	CIN	-	10pF	$T_a = 25^\circ\text{C}$ , $f = 1\text{MHZ}$
Output Capacitance	COUT	-	10pF	$T_a = 25^\circ\text{C}$ , $f = 1\text{MHZ}$

**AC CHARACTERISTICS** ( $T_a = 0^\circ\text{C} \sim 70^\circ\text{C}$ ,  $V_{CC} = 5V \pm 10\%$ )

Item	Symbol	23C8100-10		23C8100-12		23C8100-15	
		MIN.	MAX.	MIN.	MAX.	MIN.	MAX.
Read Cycle Time	tRC	100ns	-	120ns	-	150ns	-
Address Access Time	tAA	-	100ns	-	120ns	-	150ns
Chip Enable Access Time	tACE	-	100ns	-	120ns	-	150ns
Output Enable Time	tOE	-	50ns	-	60ns	-	70ns
Output Hold After Address	tOH	0ns	-	0ns	-	0ns	-
Output High Z Delay	tHZ	-	20ns	-	20ns	-	20ns

Note: Output high-impedance delay (tHZ) is measured from  $\overline{OE}$  or  $\overline{CE}$  going high, and this parameter guaranteed by design over the full voltage and temperature operating range - not tested.

## AC Test Conditions

Input Pulse Levels	0.4V~2.4V
Input Rise and Fall Times	10ns
Input Timing Level	1.5V
Output Timing Level	0.8V and 2.0V
Output Load	See Figure

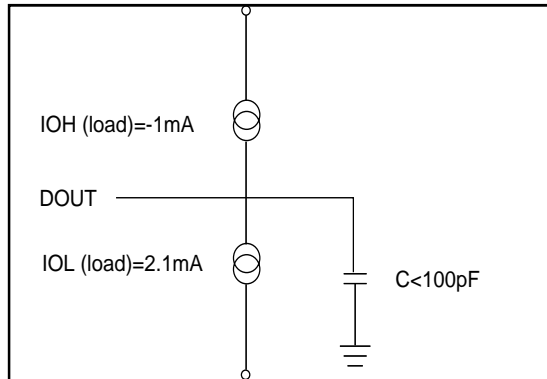

Note:

No output loading is present in tester load board.

Active loading is used and under software programming control.

Output loading capacitance includes load board's and all stray capacitance.

## TIMING DIAGRAM

### RANDOM READ

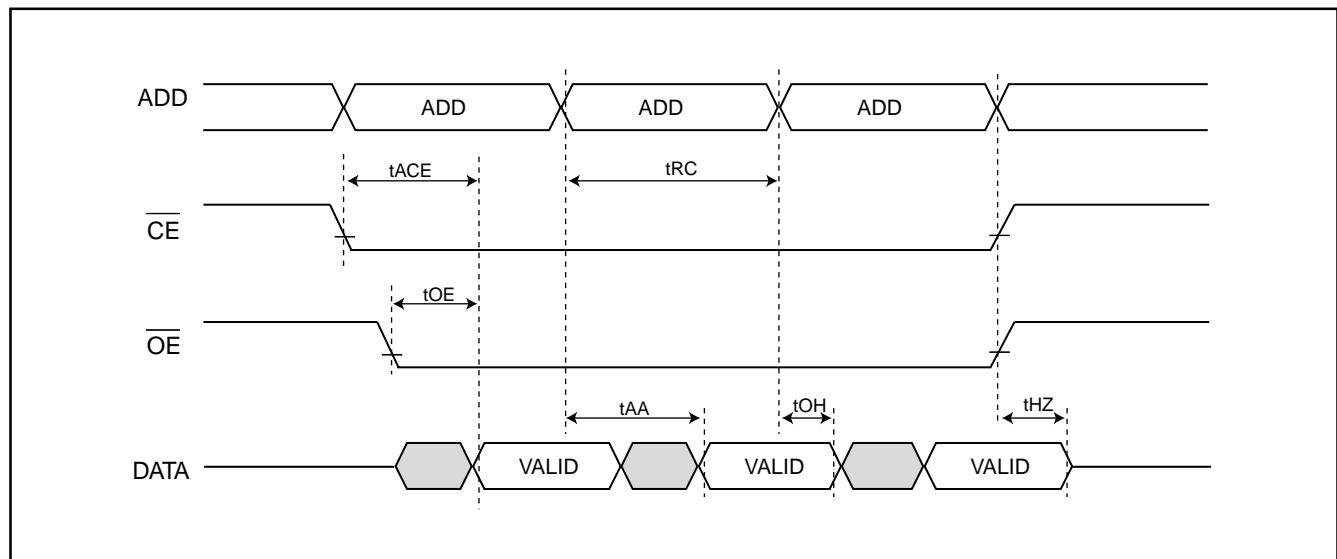

## PACKAGE INFORMATION

### 42-PIN PLASTIC DIP(600 mil)

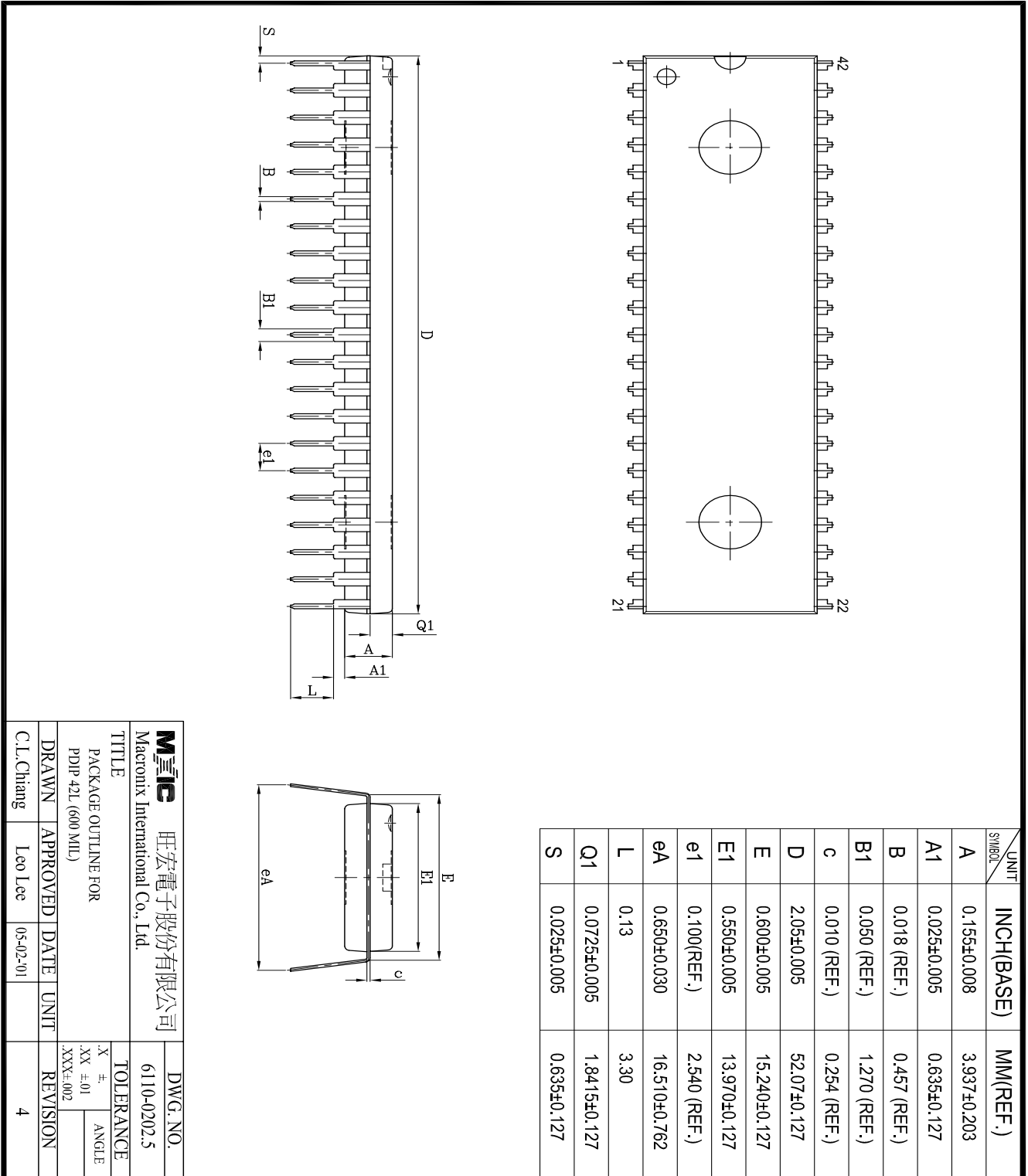

<b>Mxic</b> 旺宏電子股份有限公司 Macronix International Co., Ltd.		DWG. NO. 6110-0202.5	
TITLE PACKAGE OUTLINE FOR PDP 42L (600 MIL)		TOLERANCE X #. XX ±.01 .XXX±.002	
DRAWN	APPROVED	DATE	UNIT
C.L.Chang	Leo Lee	05-02-01	
		REVISION	4

## 44-PIN PLASTIC SOP

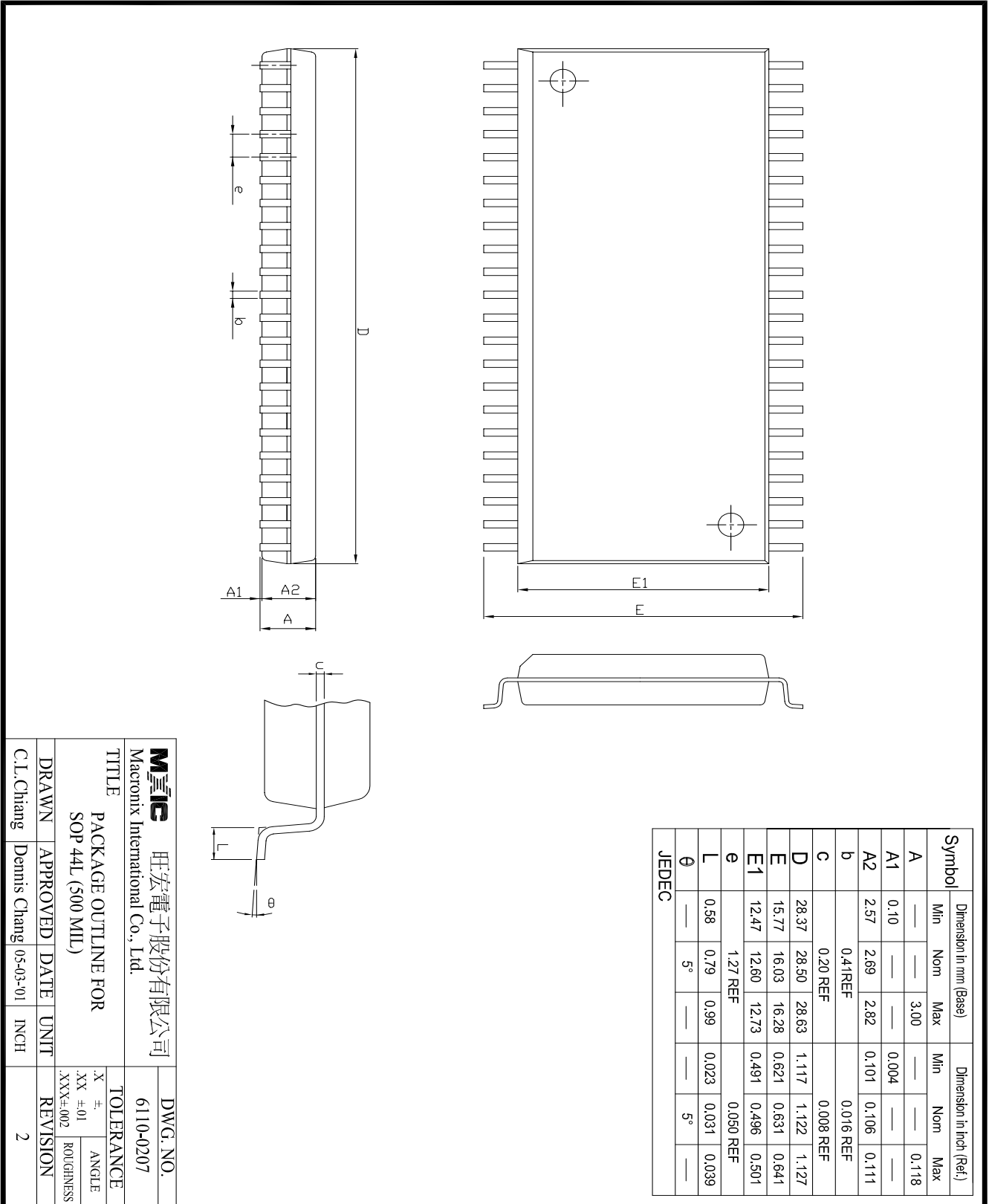

<b>Mxic</b> 旺宏電子股份有限公司 Macronix International Co., Ltd.		DWG. NO. 6110-0207	
TITLE PACKAGE OUTLINE FOR SOP 44L (500 MIL)			
DRAWN	APPROVED	DATE	UNIT
C.L.Chang	Dennis Chang	05-03-01	INCH
TOLERANCE		REVISION	
.X ±	ANGLE	2	
.XX ±.01	ROUGHNESS		
.XXX±.002			

## 48-PIN PLASTIC TSOP

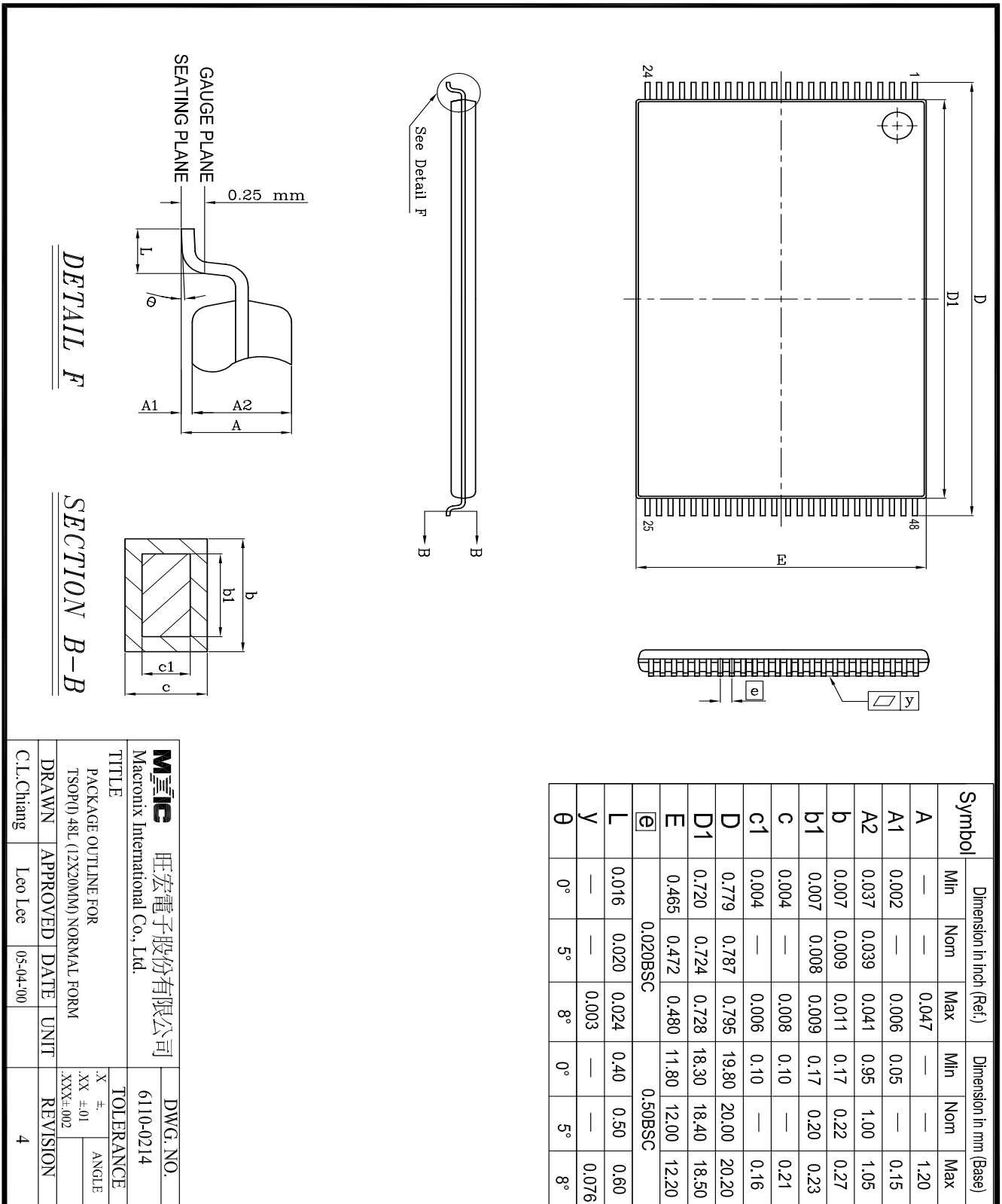

**DETAIL F**

**SECTION B-B**

<b>Mxic</b> 旺宏電子股份有限公司 Macronix International Co., Ltd.		DWG. NO. 6110-0214	
TITLE PACKAGE OUTLINE FOR TSOP(D) 48L (12X20MM) NORMAL FORM			
DRAWN	APPROVED	DATE	UNIT
C.L.Chang	Leo Lee	05-04-00	
TOLERANCE		REVISION	
.X ±.01		4	
.XX ±.01			
.XXX±.002			

**REVISION HISTORY**

Revision	Description	Page	Date
4.2	DC Characteristics: The standby current (CMOS) ISTB2 is changed as 50us instead of 100uA. AC Characteristics: Deleted 200ns grade item. The output enable time (tOE) is changed as 60ns instead of 70ns in 120ns grade item, and 70ns instead of 80ns in 150ns grade item. The output high Z delay is changed as 20ns instead of 70ns.		SEP/01/1997
4.3	AC CHARACTERISTICS tOH 10ns-->0ns	P3	JAN/28/1999
4.4	Undershoot -1.3V 20ns-->-2.0V 20ns	P2	AUG/04/1999
4.5	Added Package Information	P5~7	JUL/16/2001





**MX23C8100**

---

---

**MACRONIX INTERNATIONAL Co., LTD.**

**HEADQUARTERS:**

TEL:+886-3-578-6688

FAX:+886-3-563-2888

**EUROPE OFFICE:**

TEL:+32-2-456-8020

FAX:+32-2-456-8021

**JAPAN OFFICE:**

TEL:+81-44-246-9100

FAX:+81-44-246-9105

**SINGAPORE OFFICE:**

TEL:+65-348-8385

FAX:+65-348-8096

**TAIPEI OFFICE:**

TEL:+886-2-2509-3300

FAX:+886-2-2509-2200

**MACRONIX AMERICA, INC.**

TEL:+1-408-453-8088

FAX:+1-408-453-8488

**CHICAGO OFFICE:**

TEL:+1-847-963-1900

FAX:+1-847-963-1909

**[http : //www.macronix.com](http://www.macronix.com)**