

REALTEK

ALC650-VF
ALC650-VF-LF

SIX-CHANNEL AC'97 AUDIO CODEC

DATASHEET

Rev. 1.3
06 December 2005
Track ID: JATR-1076-21



Realtek Semiconductor Corp.

No. 2, Innovation Road II, Hsinchu Science Park, Hsinchu 300, Taiwan

Tel.: +886-3-578-0211. Fax: +886-3-577-6047

www.realtek.com.tw

COPYRIGHT

©2005 Realtek Semiconductor Corp. All rights reserved. No part of this document may be reproduced, transmitted, transcribed, stored in a retrieval system, or translated into any language in any form or by any means without the written permission of Realtek Semiconductor Corp.

DISCLAIMER

Realtek provides this document “as is”, without warranty of any kind, neither expressed nor implied, including, but not limited to, the particular purpose. Realtek may make improvements and/or changes in this document or in the product described in this document at any time. This document could include technical inaccuracies or typographical errors.

TRADEMARKS

Realtek is a trademark of Realtek Semiconductor Corporation. Other names mentioned in this document are trademarks/registered trademarks of their respective owners.

CONFIDENTIALITY

This document is confidential and should not be provided to a third-party without the permission of Realtek Semiconductor Corporation.

USING THIS DOCUMENT

This document is intended for the software engineer’s reference and provides detailed programming information.

Though every effort has been made to ensure that this document is current and accurate, more information may have become available subsequent to the production of this guide. In that event, please contact your Realtek representative for additional information that may help in the development process.

REVISION HISTORY

Revision	Release Date	Summary
1.3	2005/12/06	Update section 6.1.12 MX1A Record Select, page 11. Update section 12. Ordering Information, page 42.

Table of Contents

1. GENERAL DESCRIPTION	1
2. FEATURES	1
3. BLOCK DIAGRAM	2
4. PIN ASSIGNMENTS	3
4.1 LEAD (PB)-FREE PACKAGE AND VERSION IDENTIFICATION.....	3
5. PIN DESCRIPTION	4
5.1 DIGITAL I/O PINS.....	4
5.2 ANALOG I/O PINS.....	4
5.3 FILTER/REFERENCE.....	5
5.4 POWER/GROUND.....	5
5.5 CRYSTAL SELECTION.....	5
6. REGISTERS	6
6.1 MIXER REGISTERS.....	6
6.1.1 MX00 Reset.....	7
6.1.2 MX02 Master Volume.....	7
6.1.3 MX06 MONO_OUT Volume.....	8
6.1.4 MX0A PC BEEP Volume.....	8
6.1.5 MX0C PHONE Volume.....	9
6.1.6 MX0E MIC Volume.....	9
6.1.7 MX10 LINE_IN Volume.....	9
6.1.8 MX12 CD Volume.....	10
6.1.9 MX14 VIDEO Volume.....	10
6.1.10 MX16 AUX Volume.....	10
6.1.11 MX18 PCM_OUT Volume.....	11
6.1.12 MX1A Record Select.....	11
6.1.13 MX1C Record Gain.....	12
6.1.14 MX20 General Purpose Register.....	12
6.1.15 MX22 3D Control.....	12
6.1.16 MX26 Powerdown Control/Status.....	13
6.1.17 MX28 Extended Audio ID.....	14
6.1.18 MX2A Extended Audio Status and Control Register.....	15
6.1.19 MX2C PCM Front/Center Output Sample Rate.....	16
6.1.20 MX2E PCM Surround Output Sample Rate.....	16
6.1.21 MX30 PCM LFE Output Sample Rate.....	17
6.1.22 MX32 PCM Input Sample Rate.....	17
6.1.23 MX36 LFE/Center Master Volume.....	17
6.1.24 MX38 Surround Master Volume.....	18
6.1.25 MX3A S/PDIF Output Channel Status and Control.....	18
6.1.26 MX64 Surround DAC Volume.....	19
6.1.27 MX66 Center/LFE DAC Volume.....	19
6.2 VENDOR DEFINED REGISTERS.....	19
6.2.1 MX60 S/PDIF Input Channel Status [15:0].....	19

6.2.2	<i>MX62 S/PDIF Input Channel Status [29:15]</i>	20
6.2.3	<i>MX6A Multi-Channel Control</i>	21
6.3	EXTENSION REGISTERS	23
6.3.1	<i>MX76 GPIO Setup</i>	23
6.3.2	<i>MX78 GPIO Status</i>	24
6.3.3	<i>MX7A Clock Source, Pin-47, S/PDIF Input Receiver</i>	25
6.3.4	<i>MX7C VENDOR ID1</i>	25
6.3.5	<i>MX7E VENDOR ID2</i>	25
6.3.6	<i>MX74 MISCELLANEOUS CONTROL</i>	26
7.	ELECTRICAL CHARACTERISTICS	27
7.1	DC CHARACTERISTICS	27
7.2	AC TIMING CHARACTERISTICS	27
7.2.1	<i>Cold Reset</i>	27
7.2.2	<i>Warm Reset</i>	28
7.2.3	<i>AC-Link Clocks</i>	28
7.2.4	<i>Data Output and Input Times</i>	29
7.2.5	<i>Signal Rise and Fall Times</i>	30
7.2.6	<i>AC-Link Low Power Mode Timing</i>	31
7.2.7	<i>ATE Test Mode</i>	31
7.2.8	<i>AC-Link IO Pin Capacitance and Loading</i>	32
7.2.9	<i>SPDIF Output</i>	32
7.2.10	<i>BIT-CLK and SDATA-IN State</i>	32
8.	ANALOG PERFORMANCE CHARACTERISTICS	33
9.	DESIGN SUGGESTIONS	34
9.1	CLOCKING	34
9.2	AC-LINK	34
9.3	RESET	35
9.4	CD INPUT	35
9.5	ODD ADDRESSED REGISTER ACCESS	35
9.6	POWER-DOWN MODE	36
9.7	TEST MODE	36
9.7.1	<i>ATE In Circuit Test Mode</i>	36
9.7.2	<i>Vendor Specific Test Mode</i>	36
10.	APPLICATION CIRCUITS	37
11.	MECHANICAL DIMENSIONS	41
12.	ORDERING INFORMATION	42

1. General Description

The ALC650 is an 18-bit, full duplex AC'97 2.2 compatible stereo audio CODEC designed for PC multimedia systems, including host/soft audio and AMR/CNR based designs. The ALC650 incorporates proprietary converter technology to achieve a high SNR, greater than 90 dB. The ALC650 AC'97 CODEC supports multiple CODEC extensions with independent variable sampling rates and built-in 3D effects. The ALC650 CODEC provides three pairs of stereo outputs with independent volume controls, a mono output, and multiple stereo and mono inputs, along with flexible mixing, gain and mute functions to provide a complete integrated audio solution for PCs.

The digital interface circuitry of the ALC650 CODEC operates from a 3.3V power supply with EAPD (External Amplifier Power Down) control for use in notebook and PC applications. The ALC650 integrates a 50mW/20ohm headset audio amplifier into the CODEC, which can save BOM costs. The ALC650 also supports an AC'97 2.2 compliant SPDIF out function which allows easy connection of the PC to consumer electronic products, such as AC3 decoder/speaker and minidisk. The ALC650 CODEC supports host/soft audio from Intel 810/815/820/845 chipsets as well as audio controller based VIA/SIS/ALI chipsets. Bundled Windows series drivers (Win95/98/ME/2000/XP/NT) and sound effect utilities (supporting Karaoke, emulation of 26 sound environments, and 10-band equalizer) provide a more comprehensive entertainment package for PC users. Finally, internal PLL circuits generate required timing signals, eliminating the need for external clocking devices.

2. Features

- High performance CODEC with high S/N ratio (>90 dB)
- 18-bit ADC and 20-bit DAC resolution
- Compliant with AC'97 2.2 specifications
- 18-bit stereo full-duplex CODEC with independent and variable sampling rate
- 4 analog line-level stereo inputs with 5-bit volume control: LINE_IN,CD,VIDEO,AUX
- 2 analog line-level mono inputs: PC_BEEP,PHONE_IN
- Mono output with 5-bit volume control
- Stereo output with 5-bit volume control
- 6 channel slot selectable DAC output for multi-channel applications
- One standard MIC input, and one dedicated Front-MIC input for front panel applications (software selectable)
- LINE Inputs shared with surround output; MIC1 and MIC2 shared with Center and LFE output
- 2 MIC inputs, which are software selectable
- Power management capabilities
- 3D Stereo enhancement
- Embedded 50mW/20ohm OP at front LINE output
- External amplifier power down capability
- Digital S/PDIF output
- Digital S/PDIF input. (ALC650 Rev. E or later)
- No external crystal/clock required
- Supports 1 general purpose I/O pin
- Power supply: Digital:3.3V; Analog: 5V/3.3V
- Standard 48-Pin LQFP Package

3. Block Diagram

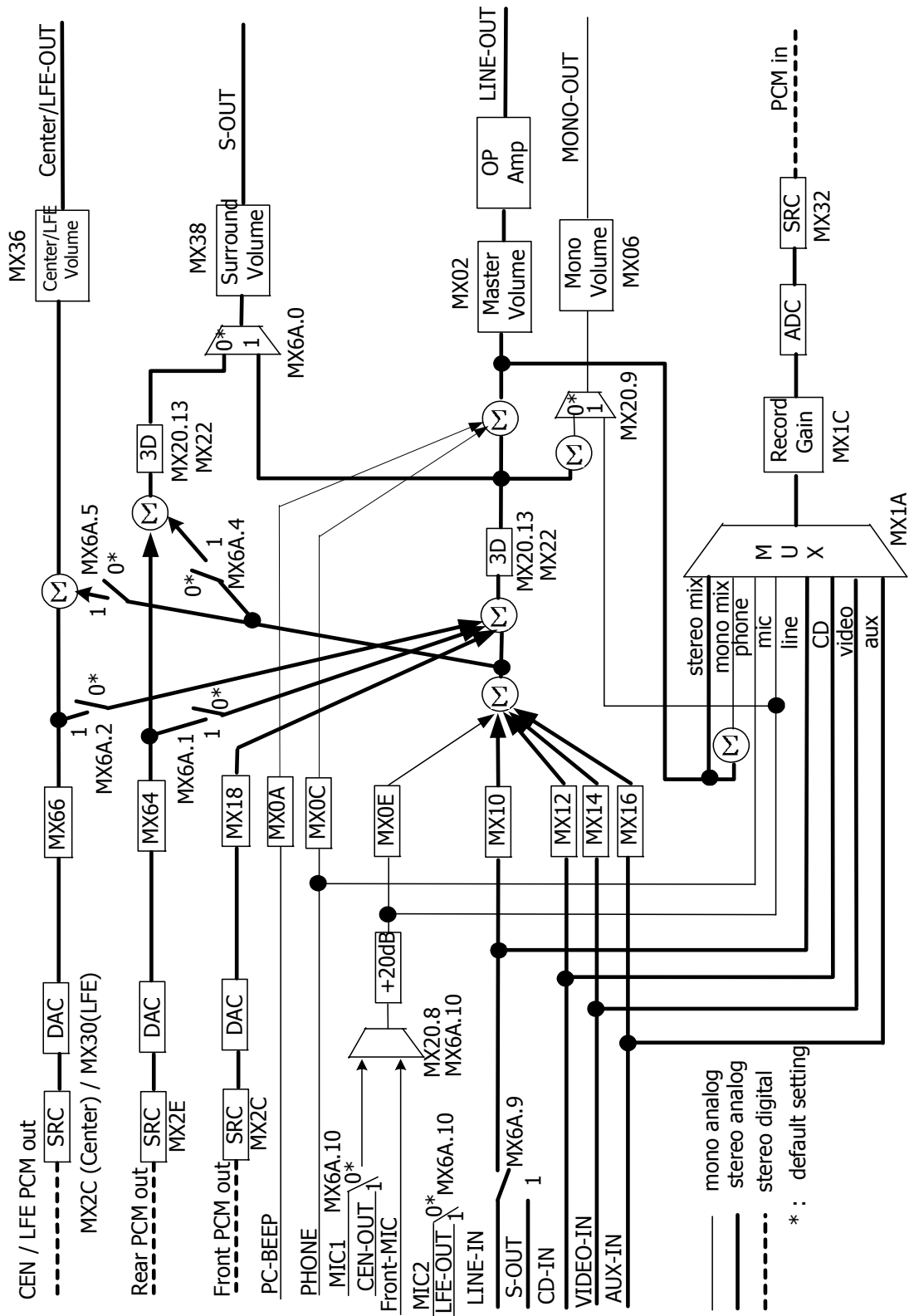

4. Pin Assignments

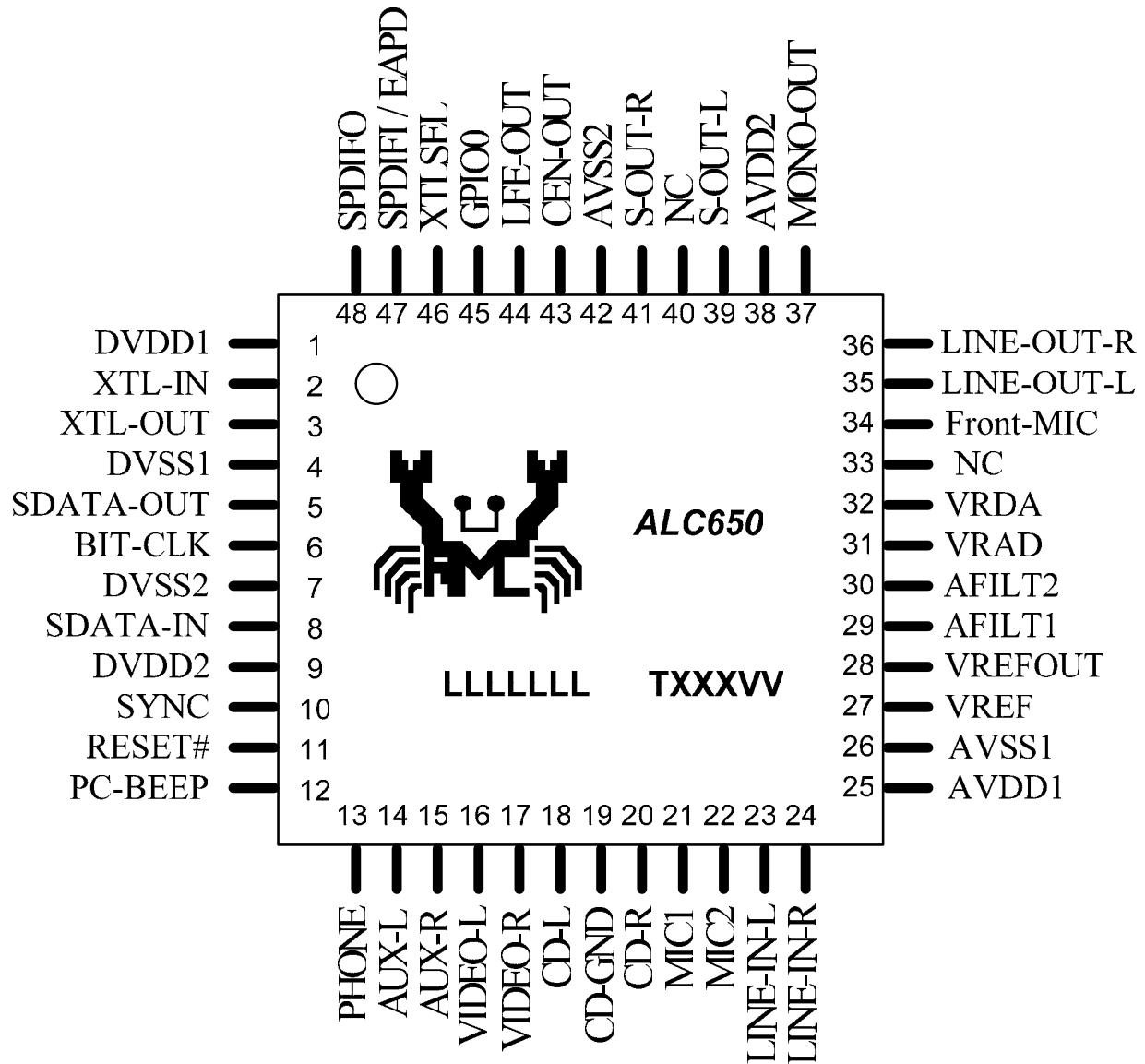

4.1 Lead (Pb)-Free Package and Version Identification

Lead (Pb)-free package is indicated by an 'L' in the location marked 'T' in the figures above. The version number is shown in the location marked 'VV'.

5. Pin Description

5.1 Digital I/O Pins

Name	Type	Pin No	Description	Characteristic Definition
RESET#	I	11	AC'97 master H/W reset	Schmitt input, $V_L=0.3V_{dd}$, $V_H=0.4V_{dd}$
XTL-IN	I	2	Crystal input pad (24.576Mhz)	Crystal input pad
XTL-OUT	O	3	Crystal output pad	Crystal output pad
SYNC	I	10	Sample Sync (48Khz)	Schmitt input, $V_L=0.3V_{dd}$, $V_H=0.4V_{dd}$
BIT-CLK	IO	6	Bit clock output (12.288Mhz)	CMOS input/output, $V_t=0.35V_{dd}$, internal pulled low by a 100K resistor.
SDATA-OUT	I	5	Serial TDM AC'97 output	Schmitt input, $V_L=0.3V_{dd}$, $V_H=0.4V_{dd}$
SDATA-IN	O	8	Serial TDM AC'97 input	CMOS output, internal pulled low by a 100K resistor.
GPIO0	I/O	45	General Purpose I/O 0	
XTLSEL	I	46	Crystal Selection	
S/PDIFI / EAPD	I/O	47	S/PDIF input / External Amplifier power down control	Digital input / output
S/PDIFO	O	48	S/PDIF output	Digital output
				TOTAL: 11 Pins

5.2 Analog I/O Pins

Name	Type	Pin No	Description	Characteristic Definition
PC-BEEP	I	12	PC speaker input	Analog input (1Vrms)
PHONE	I	13	Speaker phone input	Analog input (1Vrms)
AUX-L	I	14	AUX Left channel	Analog input (1Vrms)
AUX-R	I	15	AUX Right channel	Analog input (1Vrms)
VIDEO-L	I	16	Video audio Left channel	Analog input (1Vrms)
VIDEO-R	I	17	Video audio Right channel	Analog input (1Vrms)
CD-L	I	18	CD audio Left channel	Analog input (1Vrms)
CD-GND	I	19	CD audio analog GND	Analog input (1Vrms)
CD-R	I	20	CD audio Right channel	Analog input (1Vrms)
MIC1	I / O	21	First Mic input / CEN-OUT	Analog input (1Vrms) / Analog output (1Vrms)
MIC2	O	22	Alternative LFE-OUT	Analog output (1Vrms)
LINE-L	I / O	23	Line-In Left channel / S-OUT-L	Analog input (1Vrms) / Analog output (1Vrms)
LINE-R	I / O	24	Line-In Right channel / S-OUT-R	Analog input (1Vrms) / Analog output (1Vrms)
Front-MIC	I	34	Dedicated MIC Input	Analog input (1Vrms) for front panel MIC input
LINE-OUT-L	O	35	Line-Out Left channel	Analog output (1Vrms)
LINE-OUT-R	O	36	Line-Out Right channel	Analog output (1Vrms)
MONO-OUT	O	37	Speaker Phone output	Analog output (1Vrms)
S-OUT-L	O	39	Surround Out Left channel	Analog output (1Vrms)
S-OUT-R	O	41	Surround Out Right channel	Analog output (1Vrms)
CEN-OUT	O	43	Center Out channel	Analog output (1Vrms)
LFE-OUT	O	44	Low Frequency Effect Out channel	Analog output (1Vrms)
				TOTAL: 21 Pins

5.3 Filter/Reference

Name	Type	Pin No	Description	Characteristic Definition
VREF	O	27	Reference voltage	Analog output. +4.7uF and 0.1uF cap to AVSS
VREFOUT	O	28	Ref. voltage out with 5mA drive	Analog output (2.25V – 2.75V)
AFILT1	O	29	ADC anti-aliasing filter capacitor	Analog output. 1nF cap to AVSS
AFILT2	O	30	ADC anti-aliasing filter capacitor	Analog output. 1nF cap to AVSS
VRAD	O	31	Vref for ADC	Analog output. 1uF cap to AVSS
VRDA	O	32	Vref for DAC	Analog output. 1uF cap to AVSS
TEST	O	48	Output DAC clock and ADC clock	Digital output (Test mode) (shared with SPDIFO)
NC		33,40	NC	
				TOTAL: 9 Pins

5.4 Power/Ground

Name	Type	Pin No	Description	Characteristic Definition
AVDD1	I	25	Analog VDD (5.0V)	The minimum value is 3.0V The maximum value is 5.5V
AVDD2	I	38	Analog VDD (5.0V)	The minimum value is 3.0V The maximum value is 5.5V
AVSS1	I	26	Analog GND	
AVSS2	I	42	Analog GND	
VDD1	I	1	Digital VDD (3.3V)	The minimum value is 3.0V (DVdd-0.3) The maximum value is 3.6V (DVdd+0.3)
VDD2	I	9	Digital VDD (3.3V)	The minimum value is 3.0V (DVdd-0.3) The maximum value is 3.6V (DVdd+0.3)
VSS1	I	4	Digital GND	
VSS2	I	7	Digital GND	
				TOTAL: 8 Pins

5.5 Crystal Selection

Name	Type	Pin No	Description	Characteristic Definition
XTLSEL	I	46	Crystal selection	Internal pull high
				TOTAL: 1 Pin

XTLSEL:

XTLSEL=floating, bypass 14.318MHz→24.576MHz digital PLL. The clock source is 24.576MHz crystal or external clock.

XTLSEL=pull low, select 14.318MHz→24.576MHz digital PLL

The default value of MX7A.2 is decided by XTLSEL, and, upon power up, is latched inversely to XTLSEL.

6. Registers

6.1 Mixer Registers

Access to registers with an odd number will return a 0. Reading unimplemented registers will also return a 0.

REG. (HEX)	NAME	D15	D14	D13	D12	D11	D10	D9	D8	D7	D6	D5	D4	D3	D2	D1	D0	DEFAULT
00h	Reset	X	SE4	SE3	SE2	SE1	SE0	ID9	ID8	ID7	ID6	ID5	ID4	ID3	ID2	ID1	ID0	5940h
02h	Master Volume	Mute	X	X	ML4	ML3	ML2	ML1	ML0	X	X	X	MR4	MR3	MR2	MR1	MR0	8000h
06h	Mono-Out Volume	Mute	X	X	X	X	X	X	X	X	X	X	MM4	MM3	MM2	MM1	MM0	8000h
0Ah	PC_BEEP Volume	Mute	X	X	X	X	X	X	X	X	X	X	PB3	PB2	PB1	PB0	X	0000h
0Ch	PHONE Volume	Mute	X	X	X	X	X	X	X	X	X	X	PH4	PH3	PH2	PH1	PH0	8008h
0Eh	MIC Volume	Mute	X	X	X	X	X	X	X	X	20dB	X	MI4	MI3	MI2	MI1	MI0	8008h
10h	Line-In Volume	Mute	X	X	NL4	NL3	NL2	NL1	NL0	X	X	X	NR4	NR3	NR2	NR1	NR0	8808h
12h	CD Volume	Mute	X	X	CL4	CL3	CL2	CL1	CL0	X	X	X	CR4	CR3	CR2	CR1	CR0	8808h
14h	Video Volume	Mute	X	X	VL4	VL3	VL2	VL1	VL0	X	X	X	VR4	VR3	VR2	VR1	VR0	8808h
16h	Aux Volume	Mute	X	X	AL4	AL3	AL2	AL1	AL0	X	X	X	AR4	AR3	AR2	AR1	AR0	8808h
18h	PCM Out Volume	Mute	X	X	PL4	PL3	PL2	PL1	PL0	X	X	X	PR4	PR3	PR2	PR1	PR0	8808h
1Ah	Record Select	X	X	X	X	X	LRS2	LRS1	LRS0	X	X	X	X	X	RRS2	RRS1	RRS0	0000h
1Ch	Record Gain	Mute	X	X	X	LRG3	LRG2	LRG1	LRG0	X	X	X	X	RRG3	RRG2	RRG1	RRG0	8000h
20h	General Purpose	POP	X	3D	X	X	X	MIX	MS	LBK	X	X	X	X	X	X	X	0000h
22h	3D Control	X	X	X	X	X	X	X	X	X	X	X	X	X	X	DP1	DP0	0000h
26h	Power Down Ctrl/Status	EAPD	PR6	PR5	PR4	PR3	PR2	PR1	PR0	X	X	X	X	REF	ANL	DAC	ADC	000Fh
28h	Extended Audio ID	ID1	ID0	X	X	REV1	REV0	AMA P	LDAC	SDAC	CDAC	X	X	X	SPDIF	DRA	VRA	07C7h
2Ah	Extended Audio Status	X	X	PRK	PRJ	PRI	SPCV	X	X	SDAC	X	SPSA 1	SPSA 0	X	SPDIF	DRA	VRA	0080h
2Ch	PCM front Sample Rate	FSR 15	FSR14	FSR13	FSR12	FSR11	FSR10	FSR9	FSR8	FSR7	FSR6	FSR5	FSR4	FSR3	FSR2	FSR1	FSR0	BB80h
2Eh	PCM Surr. Sample Rate	SSR 15	SSR14	SSR13	SSR12	SSR11	SSR10	SSR9	SSR8	SSR7	SSR6	SSR5	SSR4	SSR3	SSR2	SSR1	SSR0	BB80h
30h	PCM LFE. Sample Rate	SSR 15	SSR14	SSR13	SSR12	SSR11	SSR10	SSR9	SSR8	SSR7	SSR6	SSR5	SSR4	SSR3	SSR2	SSR1	SSR0	BB80h
32h	PCM Input Sample Rate	ISR 15	ISR 14	ISR 13	ISR 12	ISR 11	ISR 10	ISR 9	ISR 8	ISR 7	ISR 6	ISR 5	ISR 4	ISR 3	ISR 2	ISR 1	ISR 0	BB80h
36h	Center/LFE Volume	Mute	X	X	LFE4	LFE3	LFE2	LFE1	LFE0	Mute	X	X	CNT4	CNT3	CNT2	CNT1	CNT0	8080h
38h	Surround Volume	Mute	X	X	LSR4	LSR3	LSR2	LSR1	LSR0	Mute	X	X	RSR4	RSR3	RSR2	RSR1	RSR0	8080h
3Ah	S/PDIF Ctl	V	0	SPSR1	SPSR0	L	CC6	CC5	CC4	CC3	CC2	CC1	CC0	PRE	COPY	AUDIO	PRO	2000h
64h	Surr. DAC Volume	Mute	X	X	LSD4	LSD3	LSD2	LSD1	LSD0	X	X	X	RSD4	RSD3	RSD2	RSD1	RSD0	0808h
66h	CEN/LFE DAC Volume	Mute	X	X	LD4	LD3	LD2	LD1	LD0	X	X	X	CD4	CD3	CD2	CD1	CD0	0808h
6Ah	Multi-channel Ctl	SM1	SM0	0	X	X	X	X	0	0	0	0	0	0	0	0	0	0000h
6Eh	Vendor Define	0	0	0	0	0	0	1	0	0	0	0	0	0	0	0	0	0200h
78h	Extension Control	0	0	0	0	0	0	0	0	0	0	0	0	0	0	0	0	0000h
7Ch	Vendor ID1	0	1	0	0	0	0	0	1	0	1	0	0	1	1	0	0	414Ch
7Eh	Vendor ID2	0	1	0	0	0	1	1	1	0	0	1	0	0	0	0	0	4720h

X: reserved bit

*: MX36 is the master volume control of CENTER/LFE output.

MX38 is the master volume control of surround output.

6.1.1 MX00 Reset

Default: 5980H

Writing any value to this register will start a register reset, and causes all of the registers to revert to their default values. Reading this register returns the ID code of the specific part.

Bit	Type	Function
15	-	Reserved
14:10	R	Return 10110h (Realtek 3D Stereo Enhancement)
9	R	Read as 0 (Does not support 20-bit ADC)
8	R	Read as 1 (Supports 18-bit ADC)
7	R	Read as 1 (Supports 20-bit DAC)
6	R	Read as 0 (Does not support 18-bit DAC)
5	R	Read as 0 (No Loudness support)
4	R	Read as 0 (No True Line Level output support)
3	R	Read as 0 (No simulated stereo for analog 3D block use)
2	R	Read as 0 (No Bass & Treble Control)
1	R	Read as 0 (No Modem Line support)
0	R	Read as 0 (No Dedicated Mic PCM input channel)

- ❶ Writing any data into this register will reset all mixer registers to their default value. The written data is ignored.

6.1.2 MX02 Master Volume

Default: 8000H

These registers control the overall volume level of the output functions. Each step on the left and right channels correspond to 1.5dB in increase/decrease in volume.

Bit	Type	Function
15	R/W	Mute Control 0: Normal 1: Mute (-∞ dB)
14:13	-	Reserved
12:8	R/W	Master Left Volume (ML[4:0]) in 1.5 dB steps
7:5	-	Reserved
4:0	R/W	Master Right Volume (MR[4:0]) in 1.5 dB steps

- ❶ For MR/ML, 00h +3 dB gain for D/E version, 0dB for F version
02h 0 dB gain for D/E version, -3dB (attenuation) for F version
1Fh -43.5 dB (attenuation) for D/E version, -45dB for F version
- ❷ MR/ML are 5-bit R/W variables. The 6th bit implementation is optional. For this reason, when 6th bit is written by 1, it is equivalent to writing low 5-bit with 1. For example, writing 1xxxx will read back 01111.

6.1.3 MX06 MONO_OUT Volume

Default: 8000H

Register 06H controls the mono volume output. Mono output is the same data sent on all output channels. Each step in bits 0:4 correspond to 1.5dB in increase/decrease in volume, allowing 32 levels of volume from 00000 to 11111.

Bit	Type	Function
15	R/W	Mute Control 0: Normal 1: Mute ($-\infty$ dB)
14:5	-	Reserved
4:0	R/W	Mono Master Volume (MM[4:0]) in 1.5 dB steps

- ❶ For MM, 00h 0 dB attenuation
1Fh 46.5 dB attenuation
- ❷ Implement 5-bit volume control only. Writing 1xxxxx will be interpreted as x11111 and respond when read with x11111 as well.

6.1.4 MX0A PC BEEP Volume

Default: 0000H

This register controls the input volume for the PC beep signal. Each step in bits 4:1 correspond to a 3dB increase/decrease in volume. 16 levels of volume are available, from 0000 to 1111.

The purpose of this register is to allow the PC Beep signals to pass through the ALC650, eliminating the need for an external system speaker/buzzer. The PC BEEP pin is directly routed (internally hardwired) to the LINE-OUTL & R pins. If the PC speaker/buzzer is eliminated, it is recommended to connect the external speakers at all times so the POST codes can be heard during reset.

Bit	Type	Function
15	R/W	Mute Control 0: Normal 1: Mute ($-\infty$ dB)
14:5	-	Reserved
4:1	R/W	PC Beep Volume (PB[3:0]) in 3 dB steps
0	-	Reserved

- ❶ For PB, 00h 0 dB attenuation
0Fh 45 dB attenuation

6.1.5 MX0C PHONE Volume

Default: 8008H

Register 0CH controls the telephone input volume for software modem applications. Because software modem applications may not have a speaker, the CODEC can offer a speaker-out service. Each step in bits 4:0 correspond to 1.5dB in increase/decrease in volume, allowing 32 levels of volume, from 00000 to 11111.

Bit	Type	Function
15	R/W	Mute Control 0: Normal 1: Mute (-∞ dB)
14:5	-	Reserved
4:0	R/W	Phone Volume (PV[4:0]) in 1.5 dB steps

- ① For PV,

00h	+12 dB Gain
08h	0dB gain
1Fh	-34.5dB Gain

6.1.6 MX0E MIC Volume

Default: 8008H

Register 0EH controls the microphone input volume. Each step in bits 4:0 correspond to 1.5dB in increase/decrease in volume, allowing 32 levels of volume, from 00000 to 11111. Each step in bit 6 corresponds to a magnification of 20dB increase in volume.

Bit	Type	Function
15	R/W	Mute Control 0: Normal 1: Mute (-∞ dB)
14:7	-	Reserved
6	R/W	20 dB Boost Control 0: Normal 1: 20 dB boost
5	-	Reserved
4:0	R/W	Mic Volume (MV[4:0]) in 1.5 dB steps

- ① For MV,

00h	+12 dB Gain
08h	0dB gain
1Fh	-34.5dB Gain

6.1.7 MX10 LINE_IN Volume

Default: 8808H

Register 10H controls the LINE_IN input volume. Each step in bits 4:0 correspond to 1.5dB in increase/decrease in volume for the right channel, allowing 32 levels of volume, from 00000 to 11111. Each step in bits 12:8 correspond to 1.5dB in increase/decrease in volume for the left channel, allowing 32 levels of volume, from 00000 to 11111.

Bit	Type	Function
15	R/W	Mute Control 0: Normal 1: Mute (-∞ dB)
14:13	-	Reserved
12:8	R/W	Line-In Left Volume (NL[4:0]) in 1.5 dB steps
7:5	-	Reserved
4:0	R/W	Line-In Right Volume (NR[4:0]) in 1.5 dB steps

- ① For NL/NR,

00h	+12 dB Gain
08h	0dB gain
1Fh	-34.5dB Gain

6.1.8 MX12 CD Volume

Default: 8808H

Register 12H controls the CD input volume. Each step in bits 4:0 correspond to 1.5dB in increase/decrease in volume for the right channel, allowing 32 levels of volume, from 00000 to 11111. Each step in bits 12:8 correspond to 1.5dB in increase/decrease in volume for the left channel, allowing 32 levels of volume, from 00000 to 11111.

it	Type	Function
15	R/W	Mute Control 0: Normal 1: Mute ($-\infty$ dB)
14:13	-	Reserved
12:8	R/W	CD Left Volume (CL[4:0]) in 1.5 dB steps
7:5	-	Reserved
4:0	R/W	CD Right Volume (CR[4:0]) in 1.5 dB steps

- ① For CL/CR, 00h +12 dB Gain
08h 0dB gain
1Fh -34.5dB Gain

6.1.9 MX14 VIDEO Volume

Default: 8808H

Register 14H controls the video input volume. Each step in bits 4:0 correspond to 1.5dB in increase/decrease in volume for the right channel, allowing 32 levels of volume, from 00000 to 11111. Each step in bits 12:8 correspond to 1.5dB in increase/decrease in volume for the left channel, allowing 32 levels of volume, from 00000 to 11111.

Bit	Type	Function
15	R/W	Mute Control 0: Normal 1: Mute ($-\infty$ dB)
14:13	-	Reserved
12:8	R/W	Video Left Volume (VL[4:0]) in 1.5 dB steps
7:5	-	Reserved
4:0	R/W	Video Right Volume (VR[4:0]) in 1.5 dB steps

- ① For VL/VR, 00h +12 dB Gain
08h 0dB gain
1Fh -34.5dB Gain

6.1.10 MX16 AUX Volume

Default: 8808H

Register 16H controls the auxiliary input volume. Each step in bits 4:0 correspond to 1.5dB in increase/decrease in volume for the right channel, allowing 32 levels of volume, from 00000 to 11111. Each step in bits 12:8 correspond to 1.5dB in increase/decrease in volume for the left channel, allowing 32 levels of volume, from 00000 to 11111.

Bit	Type	Function
15	R/W	Mute Control 0: Normal 1: Mute ($-\infty$ dB)
14:13	-	Reserved
12:8	R/W	AUX Left Volume (AL[4:0]) in 1.5 dB steps
7:5	-	Reserved
4:0	R/W	AUX Right Volume (AR[4:0]) in 1.5 dB steps

- ① For AL/AR, 00h +12 dB Gain
08h 0dB gain
1Fh -34.5dB Gain

6.1.11 MX18 PCM_OUT Volume

Default: 8808H

Register 18H controls the PCM_OUT output volume. Each step in bits 4:0 correspond to 1.5dB in increase/decrease in volume for the right channel, allowing 32 levels of volume, from 00000 to 11111. Each step in bits 12:8 correspond to 1.5dB in increase/decrease in volume for the left channel, allowing 32 levels of volume, from 00000 to 11111.

Bit	Type	Function
15	R/W	Mute Control 0: Normal 1: Mute (-∞ dB)
14:13	-	Reserved
12:8	R/W	PCM Left Volume (PL[4:0]) in 1.5 dB steps
7:5	-	Reserved
4:0	R/W	PCM Right Volume (PR[4:0]) in 1.5 dB steps

- ① For PL/PR,
 - 00h +12 dB Gain
 - 08h 0dB gain
 - 1Fh -34.5dB Gain

6.1.12 MX1A Record Select

Default: 0000H

Register 1AH controls the record input source. Each bit in bits 2:0 selects a recording source for the right channel. Each bit in bits 10:8 selects a recording source for the left channel.

Bit	Type	Function
15:11	-	Reserved
10:8	R/W	Left Record Source Select (LRS[2:0])
7:3	-	Reserved
2:0	R/W	Right Record Source Select (RRS[2:0])

- ① For LRS
 - 0 MIC
 - 1 CD LEFT
 - 2 VIDEO LEFT
 - 3 AUX LEFT
 - 4 LINE LEFT
 - 5 STEREO MIXER OUTPUT LEFT
 - 6 MONO MIXER OUTPUT
 - 7 PHONE
- ② For RRS
 - 0 MIC
 - 1 CD RIGHT
 - 2 VIDEO RIGHT
 - 3 AUX RIGHT
 - 4 LINE RIGHT
 - 5 STEREO MIXER OUTPUT RIGHT
 - 6 MONO MIXER OUTPUT
 - 7 PHONE

6.1.13 MX1C Record Gain

Default: 8000H

Register 1CH controls the record gain. Each step in bits 3:0 correspond to 1.5dB in increase/decrease in gain for the right channel, allowing 16 levels of gain, from 0000 to 1111. Each step in bits 11:8 correspond to 1.5dB in increase/decrease in gain for the left channel, allowing 16 levels of gain, from 0000 to 1111.

Bit	Type	Function
15	R/W	Mute Control 0: Normal 1: Mute (-∞ dB)
14:12	-	Reserved
11:8	R/W	Left Record Gain Select (LRG[3:0]) in 1.5 dB steps
7:4	-	Reserved
3:0	R/W	Right Record Gain Select (RRG[3:0]) in 1.5 dB steps

- ❶ For LRG/RRG, 0Fh +22.5dB
00h 0 dB (No Gain)

6.1.14 MX20 General Purpose Register

Default: 0000H

This register is used to control several functions. Bit 13 enables or disables 3D control. Bit 9 allows selection of mono output. Bit 8 controls the mic selector. Bit 7 enables loopback of the AD output to the DA input without involving the AC-Link, allowing for full system performance measurements.

Bit	Type	Function
15:14	-	Reserved, Read as 0
13	R/W	3D Control 1: On 0: Off
12:10	-	Reserved, Read as 0
9	R/W	Mono Output Select 0: MIX 1: MIC
8	R/W	Mic Select 0: MIC1 1: MIC1 + Front MIC MX20.8 and MX6A.10 configure MIC1/Front MIC input. Refer to MX6A.10 for detailed information.
7	R/W	AD to DA Loop-Back Control 0: Disable 1: Enable
6:0	-	Reserved

- ❶ Bit 13 is used to turn on 3D effects in both front and surround path.
- ❷ Bit 7 enables ADC to front DAC loop-back.

6.1.15 MX22 3D Control

Default: 0000H

This register is used to control the 3D stereo enhancement function built into the AC'97 component. The register bits, DP1-DP0 are used to control the separation ratios in the 3D control for both LINE_OUT and DAC_OUT respectively. This allows for independent control of the stereo enhancement between LINE_OUT and DAC_OUT.

The 3D stereo enhancement function provides for a deeper and wider sound experience with a potential 6-speaker arrangement. Note that the 3D bit in the general purpose register (bit 13) must be set to 1 to enable this function.

Bit	Type	Function
15:2	-	Reserved, Read as 0
1:0	R/W	Depth control (DP[1:0])

- ❶ 3D effect control

DP[1:0]	Function
00	0%(off)
01	50%
10	75%
11	100%

6.1.16 MX26 Powerdown Control/Status

Default: 0000H

This read/write register is used to program powerdown states and monitor subsystem readiness. The lower half of this register is read only status; a “1” indicating that the subsection is “ready.” Ready is defined as the subsection’s ability to perform in its nominal state.

When the AC-Link “CODEC Ready” indicator bit (SDATA_IN slot 0, bit 15) is a 1, it indicates that the AC-Link and AC’97 control and status registers are in a fully operational state. The AC’97 controller must further probe this powerdown control /status register to determine exactly which subsections, if any are ready.

Bit	Type	Function
15	R/W	PR7 External Amplifier Power Down (EAPD) 0: EAPD output low (enable external amplifier) 1: EAPD output high (shut down external amplifier)
14	-	Reserved
13	R/W	PR5 0: Normal 1: Disable internal clock usage (BCLK still be output for modem CODEC)
12	R/W	PR4 0: Normal 1: Power down AC-Link
11	R/W	PR3 0: Normal 1: Power down Mixer (Vref off)
10	R/W	PR2 0: Normal 1: Power down Mixer (Vref still on)
9	R/W	PR1 0: Normal 1: Power down PCM DAC (front DAC)
8	R/W	PR0 0: Normal 1: Power down PCM ADC and input MUX
7:4	-	Reserved, Read as 0
3	R	Vref Status 1: Vref is up to normal level 0: Not yet
2	R	Analog Mixer Status 1: Ready 0: Not yet
1	R	DAC Status 1: Ready 0: Not yet
0	R	ADC Status 1: Ready 0: Not yet

Truth table for power down mode:

	CDAC	SDAC *	LDAC	ADC	DAC	Mixer	Vref	ACLINK	Int CLK	EAPD
PR0=1				PD						
PR1=1					PD					
PR2=1						PD				
PR3=1	PD	PD	PD	PD	PD	PD	PD			
PR4=1	PD	PD	PD	PD	PD			PD		
PR5=1	PD	PD	PD	PD	PD				PD	
PR7=1										High
PRI=1†	PD									
PRJ=1‡		PD								
PRK=1☼			PD							

PD: Power down Blank: Don’t care High: output high

* SDAC= Surround DAC, LDAC= LFE DAC, CDAC= Center DAC.

† PRI: Center DAC power down control bit defined in MX2A.11

‡ PRJ: Surround DAC power down control bit defined in MX2A.12

☼ PRK: LFE DAC power down control bit defined in MX2A.13

6.1.17 MX28 Extended Audio ID

Default: 07C7H

The Extended Audio ID register is a read only register used to communicate information to the digital controller on two functions. ID1 and ID0 echo the configuration of the CODEC as defined by the programming of pins 47 and 48 externally. “00” returned defines the CODEC as the primary CODEC, while any other code identifies the CODEC as one of three secondary CODEC possibilities. SDAC/LDAC/CDAC=1 tells the controller that the ALC650 is a multi-channel CODEC as defined by the Intel spec.

Bit	Type	Function
15	R	ID1 . Always read as 0
14	R	ID0 . Always read as 0
13:12	-	Reserved , Read as 0
11:10	R	REV [1:0]=01 to indicate that the ALC650 is AC'97 rev2.2 compliant
9	R	AMAP , Read as 1 (DAC mapping base on CODEC ID)
8	R	LDAC , Read as 1 (LFE DAC is supported, according to AC'97 rev2.2)
7	R	SDAC , Read as 1 (Surround DAC is supported, according to AC'97 rev2.2)
6	R	CDAC , Read as 1 (Center DAC is supported, according to AC'97 rev2.2)
5:3	-	Reserved , Read as 0
2	R	SPDIF , Read as 1 (S/PDIF is supported)
1	R	DRA , Read as 1 (Double Rate Audio is supported)
0	R	VRA , Read as 1 (Variable Rate Audio is supported)

6.1.18 MX2A Extended Audio Status and Control Register

Default: 01F0H

This register contains two active bits for powerdown and status of the surrounding DACs. Bits 0, 1 & 2 are read/write bits which are used to enable or disable VRA, DRA and SPDIF respectively. Bits 4 & 5 are read/write bits used to determine the AC-LINK slot assignment of the S/PDIF. Bits 6, 7 & 8 are read only bits which tell the controller when the Center, Surround and LFE DACs are ready to receive data. Bit 10 is a read only bit which tells the controller if the S/PDIF configuration is valid. Bits 11, 12 & 13 are read/write bits which are used to powerdown the Center, Surround and LFE DACs respectively.

Bit	Type	Function
15:14	-	Reserved
13	R/W	Power Down LFE DAC. (PRK) 0: Normal 1: Power down LFE DAC
12	R/W	Power Down Surround DAC. (PRJ) 0: Normal 1: Power down Surround DAC
11	R/W	Power Down Center DAC. (PRI) 0: Normal 1: Power down Center DAC
10	R	SPCV (S/PDIF Configuration Valid) * 0: Current S/PDIF configuration {SPSA,SPSR,DAC/slot rate} is not valid 1: Current S/PDIF configuration {SPSA,SPSR,DAC/slot rate} is valid
9	-	Reserved
8	R	LFE DAC Status (LDAC). 0: Not yet 1: Ready †
7	R	Surround DAC Status (SDAC). 0: Not yet 1: Ready †
6	R	Center DAC Status (CDAC). 0: Not yet 1: Ready †
5:4	R/W	SPSA[1:0] (S/PDIF Slot Assignment) 00: S/PDIF source data assigned to AC-LINK slot3/4 01: S/PDIF source data assigned to AC-LINK slot7/8 10: S/PDIF source data assigned to AC-LINK slot6/9 11: S/PDIF source data assigned to AC-LINK slot10/11 (default)
3	-	Reserved
2	R/W	SPDIF Enable. 1: Enable 0: Disable (Hi-Z)
1	R/W	DRA Enable. 1: Enable 0: Disable ‡
0	R/W	VRA Enable. 1: Enable 0: Disable ☼

* **SPCV** is a read only bit that indicates whether the current S/PDIF configuration is supported or not. If the configuration is supported, SPCV is set as 1 by H/W. So driver can check this bit to determine the status of the S/PDIF transmitter system. SPCV is always operating, independent of the SPDIF enable bit (MX2A.2). **The condition to allow S/PDIF output is SPDIF(MX2A.2)=1 & SPACV=1, otherwise the S/PDIF output will be all zero when MX2A.2=1 and SPACV=0 (invalid).**

† Bit-13 (PRK), bit-12(PRJ), bit-11(PRI), bit-8(LDAC), bit-7 (SDAC) and bit-6(CDAC) are extended bits defined in AC'97 specification rev 2.1.

‡ Only front DACs supports 96KHz sample rate when DRA=1. MX2A.1 just selects clock source for front DACs. **Software must set MX2C/MX2E/MX30 as BB80h, and mute surround DACs and CEN/LFE DACs.**

☼ If VRA = 0, ALC650 AD/DA operate at fixed 48KHz sampling rate. Otherwise, it operates with variable sampling rate defined in MX2C, MX2E, MX30 and MX32.

6.1.19 MX2C PCM Front/Center Output Sample Rate

Default: BB80H

The ALC650 allows adjustment of the front center output sample rate. This register is used to adjust the sample rate. By changing the values, sampling rates from 8000 to 48000 can be chosen.

Bit	Type	Function
15:0	R/W	FOSR [15:0]Output sampling rate

- ❶ The ALC650 supports the following sampling rates as required in the PC99 design guide.

Sampling rate	FOSR[15:0]
8000	1F40h
11025	2B11h
12000	2EE0h
16000	3E80h
22050	5622h
24000	5DC0h
32000	7D00h
44100	AC44h
48000	BB80h

- ❷ If the value written is not supported, the closest value is returned.
 ❸ This register controls the sample rate of *front* DAC and *center* DAC. If MX2A.0=0 (VRA is disabled), this register is always BB80h.

6.1.20 MX2E PCM Surround Output Sample Rate

Default: BB80H

The ALC650 allows adjustment of the surround output sample rate. This register is used to adjust the sample rate. By changing the values, sampling rates from 8000 to 48000 can be chosen. (See table under Section 6.1.19)

Bit	Type	Function
15:0	R/W	SOSR [15:0]Output sampling rate

- ❶ This register controls the sample rate of surround DAC. If MX2A.0=0 (VRA is disable), this register is always BB80h.
 ❷ For SOSR, please refer MX2C for detail.

6.1.21 MX30 PCM LFE Output Sample Rate

Default: BB80H

The ALC650 allows adjustment of the PCM LFE output sample rate. This register is used to adjust the sample rate. By changing the values, sampling rates from 8000 to 48000 can be chosen. (See table under Section 6.1.19)

Bit	Type	Function
15:0	R/W	LOSR [15:0]Output sampling rate

- ❶ This register controls the sample rate of LFE DAC. If MX2A.0=0 (VRA is disable), this register is always BB80h.
- ❷ For LOSR, please refer MX2C for detail.

6.1.22 MX32 PCM Input Sample Rate

Default: BB80H

The ALC650 allows adjustment of the PCM input sample rate. This register is used to adjust the sample rate. By changing the values, sampling rates from 8000 to 48000 can be chosen.

Bit	Type	Function
15:0	R/W	ISR [15:0]Output sampling rate

- ❶ ALC650 support the following sampling rate required in PC99 design guide.

Sampling rate	ISR[15:0]
8000	1F40h
11025	2B11h
12000	2EE0h
16000	3E80h
22050	5622h
24000	5DC0h
32000	7D00h
44100	AC44h
48000	BB80h

- ❷ If the value written is not support, the closest value is returned.

6.1.23 MX36 LFE/Center Master Volume

Default: 8080H

Bit	Type	Function
15	R/W	LFE Mute Control 0: Normal 1: Mute (-∞ dB)
14:13	-	Reserved
12:8	R/W	LFE Master Volume (LFE[4:0]) in 1.5 dB steps
7	R/W	Center Mute Control 0: Normal 1: Mute (-∞ dB)
6:5	-	Reserved
4:0	R/W	Center Master Volume (CNT[4:0]) in 1.5 dB steps

- ❶ For LFE/CNT, 00h 0dB Gain
1Fh -46.5dB gain
- ❷ Implement 5-bit volume control only. Writing 1xxxxx will be interpreted as x11111 and read as x11111.
- ❸ This register used to control the master volume of LFE and center output. And there is no gain for MX36.

6.1.24 MX38 Surround Master Volume

Default: 8080H

Bit	Type	Function
15	R/W	Left Mute Control 0: Normal 1: Mute ($-\infty$ dB)
14:13	-	Reserved
12:8	R/W	Surround Master Left Volume (LSR[4:0]) in 1.5 dB steps
7	R/W	Right Mute Control 0: Normal 1: Mute ($-\infty$ dB)
6:5	-	Reserved
4:0	R/W	Surround Master Right Volume (RSR[4:0]) in 1.5 dB steps

- ❶ For LSR/RSR, 00h 0dB Gain
1Fh -46.5dB gain
- ❷ Implement 5-bit volume control only. Writing 1xxxxx will be interpreted as x11111 and read as x11111.
- ❸ This register used to control the master volume of surround output. And there is no gain for MX38.

6.1.25 MX3A S/PDIF Output Channel Status and Control

Default: 2000H

Bit	Type	Function
15	R/W	Validity Control (control V bit in Sub-Frame) 0: The V bit (valid flag) in sub-frame depends on whether or not the S/PDIF data is under-run 1: The V bit in sub-frame is always send as 1 to indicate the invalid data is not suitable for receiver
14	R	DRS (Double Rate S/PDIF) The ALC650 does not support double rate S/PDIF, this bit is always 0.
13:12	R/W	SPSR [1:0] (S/PDIF Sample Rate) 00: Sample rate set to 44.1KHz. Fs[0:3]=0000 01: Reserved 10: Sample rate set to 48.0KHz. Fs[0:3]=0100 (default) 11: Sample rate set to 32.0KHz. Fs[0:3]=1100
11	R/W	LEVEL (Generation Level)
10:4	R/W	CC [6:0] (Category Code)
3	R/W	PRE (Preemphasis) 0: None 1: Filter preemphasis is 50/15 μ sec
2	R/W	COPY (Copyright) 0: Asserted 1: Not asserted
1	R/W	/AUDIO (Non-Audio Data type) 0: PCM data 1: AC3 or other digital non-audio data
0	R	PRO (Professional or Consumer format) 0: Consumer format 1: Professional format ALC650 supports consumer channel status format, this bit is always 0

- ❶ To ensure the control and status information started up correctly at the beginning of S/PDIF transmission, MX3A.[14:0] should only be written to when S/PDIF transmitter is disabled (MX2A.2=0).
- ❷ If validity control is set (MX3A.15=1), those data bits (bit 8 ~ bit 27) should be forced to 0 to get better compatibility with mini disc.

6.1.26 MX64 Surround DAC Volume

Default: 0808H

Bit	Type	Function
15	R/W	Mute Control 0: Normal 1: Mute (-∞ dB)
14:13	-	Reserved
12:8	R/W	Surround DAC Left Volume (SDL[4:0]) in 1.5 dB steps
7:5	-	Reserved
4:0	R/W	Surround DAC Right Volume (SDR[4:0]) in 1.5 dB steps

- ❶ For SDL/SDR,

00h	+12 dB Gain
08h	0dB gain
1Fh	-34.5dB Gain
- ❷ The default value is 0808H (unmuted).

6.1.27 MX66 Center/LFE DAC Volume

Default: 0808H

Bit	Type	Function
15	R/W	Mute Control 0: Normal 1: Mute (-∞ dB)
14:13	-	Reserved
12:8	R/W	LFE DAC Volume (LD[4:0]) in 1.5 dB steps
7:5	-	Reserved
4:0	R/W	Center DAC Volume (CD[4:0]) in 1.5 dB steps

- ❶ For LD/CD,

00h	+12 dB Gain
08h	0dB gain
1Fh	-34.5dB Gain
- ❷ The default value is 0808H (unmuted).

6.2 Vendor Defined Registers

These registers, as not defined in the AC'97 specifications, are available to Realtek and Realtek customers for specialized functionality.

6.2.1 MX60 S/PDIF Input Channel Status [15:0]

Default: 0000H

S/PDIF Input is implemented on the ALC650 Rev. E or later only, and this register is for use with that product only.

Bit	Type	Function
15	R	LEVEL (Generation Level)
14:8	R	CC [6:0] (Category Code)
7:6	R	Mode [1:0]
5:3	R	PRE[2:0] (Pre-Emphasis)
2	R	COPY (Copyright) 0: Asserted 1: Not asserted
1	R	/AUDIO (Non-Audio Data type) 0: PCM data 1: AC3 or other digital non-audio data
0	R	PRO (Professional or Consumer format) 0: Consumer format 1: Professional format

- ❶ The data in MX60 are captured from channel status [15:0] of SPDIFI.

6.2.2 MX62 S/PDIF Input Channel Status [29:15]

Default: 0000H

S/PDIF Input is implemented on the ALC650 Rev. E or later only, and this register is for use with that product only.

Bit	Type	Function
15	R	Vbit in Sub-frame of SPDIF-In: This bit reflects the Validity status of SPDIF-In, and is effective only when SPDIF-In is locked. This bit composed with its interrupt allows software to identify songs played by the CD ROM drive. 0: Data X and Y are valid 1: At least one of data X and Y is invalid This bit is real-time updated, and has meaning only when SPDIF-In is locked.
14	R	SPDIFI Input Signal: Locked by hardware 0: Unlocked 1: Locked
13:12	R	Ca [1:0] (Clock Accuracy)
11:8	R	Fs [3:0]. (Sample Frequency in channel status) 0000: 44.1KHz 0010: 48 KHz 0011: 32 KHz Others: Reserved
7:4	R	Cn [3:0] (Channel Number)
3:0	R	Sn [3:0] (Source Number)

- ❶ The bits [13:0] are captured from channel status [29:16] of SPDIFI.
- ❷ The consumer channel status of SPDIFI (bit0~bit31):

0	1	2	3	4	5	6	7
PRO	/AUDIO	COPY	PRE0	PRE1	PRE2	Mode0	Mode1
8	9	10	11	12	13	14	15
CC0	CC1	CC2	CC3	CC4	CC5	CC6	LEVEL
16	17	18	19	20	21	22	23
Sn0	Sn1	Sn2	Sn3	Cn0	Cn1	Cn2	Cn3
24	25	26	27	28	29	30	31
Fs0	Fs1	Fs2	Fs3	Ca0	Ca1	0	0

- ❸ SPDIF input detection is enabled by MX7A.1, MX62.14 indicates whether the SPDIF input signal is locked or not, and its channel status has been completely captured. It means that the channel status in MX60 and MX62 are meaningful only when MX62.14 is set.
- ❹ The data from SPDIF input is forced to 0 once the SPDIF input signal is unlocked. Software must check this 'LOCK' bit before dealing with SPDIF input operations.

6.2.3 MX6A Multi-Channel Control

Default: 0000h

This register is used to control various parts of the ALC650 multi-channel functions.

Bit	Type	Function
15:14	R/W	SM[1:0], Slot Modify Used to modify DAC slot #
13	R/W	Front DAC Source 0: AC-LINK Slot-3/4 (default); 1: SPDIF Input If PCM data are from SPDIFI, software must keep concurrence of sample rate of DAC and SPDIF input.
12	R/W	S/SPDIF Output Source 0: S/SPDIF output data is from controller (default) 1: S/SPDIF output data is from ADC
11	R/W	PCM Data to AC-LINK 0: PCM Data is from ADC (default) 1: PCM Data is from SPDIF input
10	R/W	MIC1 & MIC2 / CENTER & LFE Output Control 0: Pin-21 is MIC1-In, pin-22 is floating (default) 1: Pin-21 is CENTER-Out, pin-22 is LFE-Out
9	R/W	Line-In / Surround Output Control 0: Pin-23 and pin-24 are analog input (Line-In). (default) 1: Pin-23 and pin-24 are duplicated output of surround channel (Surround-Out)
8		Reserved
7	R/W	Independent Master Volume Left Control: (IMVL, Front output left channel) Used only for the ALC650 Rev. E or later. 0: Normal on; 1: Mute left channel of Master volume Mute of left Master volume = MX02.15 MX6A.7.
6	R/W	Independent Master Volume Right Control: (IMVR, Front output right channel) Used only for the ALC650 Rev. E or later. 0: Normal on; 1: Mute right channel of Master volume Mute of right Master volume = MX02.15 MX6A.6.
5	R/W	Analog Input Pass to Center/LFE Control 0: Off 1: On
4	R/W	Analog Input Pass to Surround Control 0: Off 1: On
3	R/W	Center/LFE DAC Data Exchange 0: Normal (default); 1: Exchange PCM data in Center DAC and LFE DAC. The PCM data sent to Center DAC and LFE DAC will be exchanged when this bit is set. Software must exchange the definition of volume control in MX36 and MX66.
2	R/W	Center/LFE Channel Down Mix Control. 0: Disable down mix. (default) 1: Down mix Center/LFE DAC output into LINE-OUT
1	R/W	Surround Channel Down Mix Control. 0: Disable down mix. (default) 1: Down mix surround DAC output into LINE-OUT
0	R/W	Surround Output Source. 0: S-OUT is the real surround output. (default) 1: S-OUT is the duplicated output of LINE-OUT

❶ The default source of S/SPDIF output is data sent by controller. When this bit is set, S/SPDIF data comes from ALC650's ADC is used to transfer analog input into S/SPDIF output. To keep data concurrence, **software must guarantee that the sample rates in MX32 and MX3A[13:12] are the same.** SPCV is no longer valid for an S/SPDIF configuration. If software doesn't keep the same sample rates, the S/SPDIF output will be auto forbidden by hardware, and undefined consequences may occur.

❷ ALC650 maps DAC slot according to the following table: (default maps to AC'97 spec. rev2.2)

ID[1:0]	SM[1:0]	Front Left DAC slot	Front Right DAC slot	Surr Left DAC slot	Surr Right DAC slot	Center DAC slot	LFE DAC slot
Primary ID=0,0	x,0	3	4	7	8	6	9
	x,1	3	4	6	9	7	8

⑤ Ensure that *slot request bits* definition in slot-1 of SDATA-IN *should also be changed*.

④ Data paths between S/PDIF In/Out, surround DAC and ADC are configured by MX6A.[13:11].

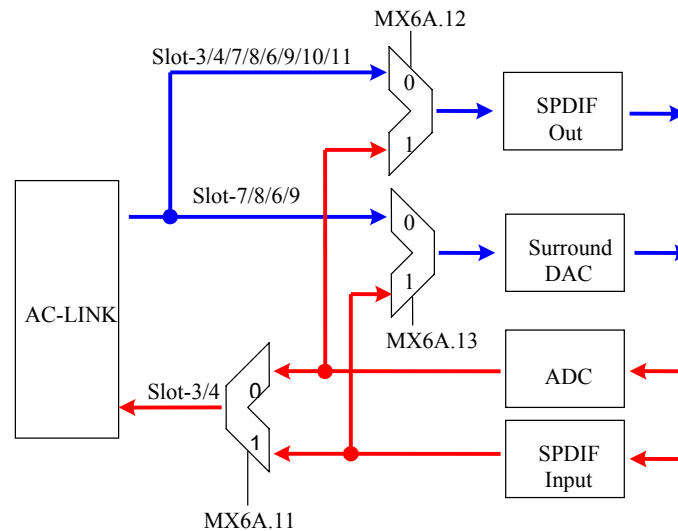

⑤ MIC2 (pin-24) is an alternative LFE output. Front-MIC is a dedicated MIC input. Therefore, MIC input is possible when MIC1/MIC2 are shared as CEN/LFE output.

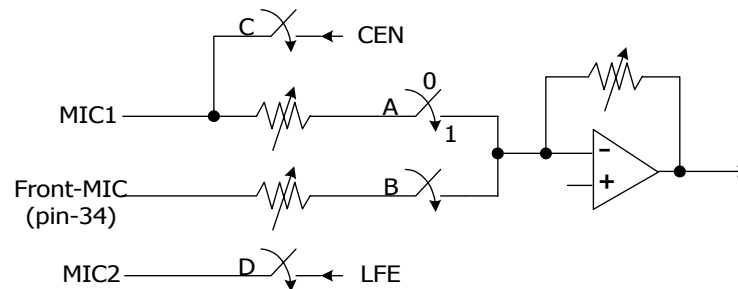

MX6A.10	MX20.8	A, B	C, D	Pin-23	Pin-24	Pin-34
0	0	1, 0	0, 0	MIC1 ✓	NC	Front-MIC ×
0	1	1, 1	0, 0	MIC1 ✓	NC	Front-MIC ✓
1	0	0, 1	1, 1	CEN-OUT ✓	LFE-OUT ✓	Front-MIC ✓
1	1	0, 1	1, 1	CEN-OUT ✓	LFE-OUT ✓	Front-MIC ✓

6.3 Extension Registers

6.3.1 MX76 GPIO Setup

Default: 0000h

Bit	Type	Function
15	R/W	GPIO Statue Indication in SDATA_IN 0: The status of GPIO0/GPIO1 and its valid tag are not indicated in SDATA_IN 1: The status of GPIO0/GPIO1 and its valid tag are indicated in SDATA_IN
14:10	-	Reserved
9	R/W	GPIO1 Interrupt Polarity 0: Low to high transition (default) 1: High to low transition
8	R/W	GPIO0 Interrupt Polarity 0: Low to high transition (default) 1: High to low transition
7	R/W	S/PDIF-In Valid Interrupt Enable 0: Disable 1: Enable
6	R/W	S/PDIF-In Lock Interrupt Enable 0: Disable 1: Enable
5	R/W	GPIO1 Interrupt Enable (when GPIO1 is used as input) 0: Disable 1: Enable A transaction which polarity depends on MX76.9 will trigger the GPIO interrupt in bit0 of SDATA_IN's slot-12. Software must confirm the primitiveness of GPIO1 before enabling GPIO1's interrupt.
4	R/W	GPIO0 Interrupt Enable (when GPIO0 is used as input) 0: Disable 1: Enable A transaction which polarity depends on MX76.8 will trigger the GPIO interrupt in bit0 of SDATA_IN's slot-12. Software must confirm the primitiveness of GPIO0 before enabling GPIO0's interrupt.
3:2	-	Reserved
1	R/W	GPIO1 Primitiveness Control 0: Set GPIO1 as input pin 1: Set GPIO1 as output pin
0	R/W	GPIO0 Primitiveness Control 0: Set GPIO0 as input pin 1: Set GPIO0 as output pin

Note that GPIO1 is not physically connected to a pad, so the system designer should not try to use it.

6.3.2 MX78 GPIO Status

Default: 0000h

Bit	Type	Function
15	R/W	Extension register Write Enable 0: Disable 1: Enable (Write control of MX 74 and MX7A)
14:10	-	Reserved
9	R/W	GPIO1 Output Control 0: Drive GPIO1 low 1: Drive GPIO1 high
8	R/W	GPIO0 Output Control 0: Drive GPIO0 as low 1: Drive GPIO0 as high
7	R/W	S/PDIF-In Valid Interrupt Status (SPDIFIN_VIS) 0: No S/PDIF-In valid interrupt. 1: S/PDIF-In Valid Interrupt. SPDIFIN_VIS=(MX76.7=1)&(SPDIF-In valid is changed)&(Locked) Write 1 to clear this status bit and its interrupt.
6	R/W	S/PDIF-In Lock Interrupt Status (SPDIFIN_LIS) 0: No S/PDIF-In lock interrupt. 1: S/PDIF-In lock interrupt. SPDIFIN_LIS= (MX76.6=1)&(SPDIF-IN lock state is changed) Write 1 to clear this status bit and its interrupt.
5	R/W	GPIO1 Interrupt Status (GPIO1_IS) . (when GPIO1 is used as input) 0: No GPIO1 interrupt 1: GPIO1 interrupt GPIO1_IS= (MX76.1==0)&(MX76.5==1) & (GPIO1 transition). Write 1 to clear this status bit.
4	R/W	GPIO0 Interrupt Status (GPIO0_IS) . (when GPIO0 is used as input) ^① 0: No GPIO0 interrupt 1: GPIO0 interrupt GPIO0_IS= (MX76.0==0)&(MX76.4==1) & (GPIO0 transition) Write 1 to clear this status bit.
3:2	-	Reserved
1	R	GPIO1 Input Status 0: GPIO1 is driven low by external device (input) 1: GPIO1 is driven high by external device (input)
0	R	GPIO0 Input Status 0: GPIO0 is driven low by external device (input) 1: GPIO0 is driven high by external device (input)

- ① Interrupt (GPINT) in bit0 of SDATA_IN slot-12 = (MX78.4 | MX78.5 | MX78.6 | MX78.7)
The transaction polarity depends on MX76.[9:8].
- ② When GPIO1/0 is used as an input pin, its status will also be reflected in bit2/1 of SDIN's slot-12. Once GPIO1/0 is used as output pin, the bit2/1 of SDATA_IN's slot-12 is always 0.
- ③ The GPIOx is internally pulled high by a weak resistor. (Weak resistor is about 50K ~ 100K ohm)

6.3.3 MX7A Clock Source, Pin-47, S/PDIF Input Receiver

Default: 0002H

This register is used for three types of information. Bit 0 is a read/write bit which enables/disables the S/PDIF input receiver. Bit 1 is used to switch pin 47, which is duplexed due for pin-count reduction, between EAPD and S/PDIF modes. Bit 2 is used to select the clock source for the ALC650.

Bit	Type	Function
15:3	-	Reserved
2	R	Clock Source Selection (XTLSEL) 0: Bypass 14.318M→24.576M digital PLL. (Default if XTSEL is floating) 1: Select 14.318M→24.576M digital PLL. (Default if XTSEL is pull low)
1	R/W	Pin-47 Control: This bit determines the function of Pin 47, a multiplexed pin. 0: EAPD (output) 1: S/PDIF Input (input) – The S/PDIF-In function is only supported by the ALC650 Rev. E or later.
0	R/W	Enable S/PDIF Input Receiver 0: Disable 1: Enable – The S/PDIF-In function is only supported by ALC650 Rev. E or later.

6.3.4 MX7C VENDOR ID1

Default: 414CH

The two registers (MX7C Vendor ID1 and MX7E Vendor ID2) contain four 8-bit ID codes. The first three codes have been assigned by Microsoft for Plug and Play definitions. The fourth code is a Realtek assigned code identifying the ALC650. The MX7C Vendor ID1 register contains the value 414Ch, which is the first and second characters of the Microsoft ID code. The MX7C Vendor ID2 register contains the value 4720h, which is the third of the Microsoft ID code.

Bit	Type	Function
15:0	R	Vendor ID “AL”

6.3.5 MX7E VENDOR ID2

Default: 4720H

Bit	Type	Function
15:8	R	Vendor ID “G”
7:4	R	Chip ID 0010
3:0	R	Version number 00: version A For WHQL issue, Here version number is always 0.

● Chip ID 0010 ALC650

6.3.6 MX74 MISCELLANEOUS CONTROL

Default: 0043H

Bit	Type	Function
15:14	-	Reserved
13	R/W	Ignore V bit in sub-frame of SPDIF-IN (Supported by the ALC650 Rev. F) 0: Disable, SPDIF-IN FIFO will keep the last valid data. (default) 1: Enable, SPDIF-IN FIFO will catch the SPDIF-In data in spite of the V bit.
12	R/W	Vrefout Disable (Supported by the ALC650 Rev. E and Rev.F) 0: Vrefout is driven by the internal reference (Default) 1: Vrefout is in high-Z mode. Software must set this bit to disable Vrefout output before MX6A.10 is set (MIC1 and MIC2 are shared as Center and LFE output).
11	R/W	S/PDIF-In Signal passed through to S/PDIF-Out (Supported by the ALC650 Rev. F) 0: Disabled, S/PDIF-Out source is decided by MX6A.12. (Default) 1: Enabled, S/PDIF-In signal passed through to S/PDIF-Out. When this bit is enabled, S/PDIF input signal is passed to S/PDIF output. System designer can use this function to do RCA to optical translation.
10	R/W	S/PDIF-In Schmitt Trigger Control (Supported by the ALC650 Rev. F) 0: Off, V_t is 1.65V (default) 1: On, V_H is 1.7V, and V_L is 1.1V.
9:0	-	Reserved

7. Electrical Characteristics

7.1 DC Characteristics

Dvdd= 3.3V±5%, T_{ambient}=25°C, with 50pF external load.

Parameter	Symbol	Minimum	Typical	Maximum	Units
Input voltage range	V _{in}	-0.30	-	DVdd+0.30	V
Low level input voltage SYNC,SDATA_OUT,RESET# XTAL_IN,BIT_CLK ID1#,ID0#	V _{IL}	-	1.2 / 0.7 1.7 / 1.0 2.0 / 1.2	0.30*DVdd - -	V
High level input voltage SYNC,SDATA_OUT,RESET# XTAL_IN,BIT_CLK ID1#,ID0#	V _{IH}	0.40*DVdd -	2.1 / 1.7 3.2 / 2.2 2.5 / 1.7	- - -	V
High level output voltage	V _{OH}	0.9DVdd	-	-	V
Low level output voltage	V _{OL}	-	-	0.1DVdd	V
Pull up resistance		50K	100K	200K	Ohm
Input leakage current	-	-10	-	10	μA
Output leakage current (Hi-Z)	-	-10	-	10	μA
Output buffer drive current	-	-	5	-	mA

7.2 AC Timing Characteristics

7.2.1 Cold Reset

Parameter	Symbol	Minimum	Typical	Maximum	Units
RESET# active low pulse width	T _{rst_low}	1.0	-	-	μs
RESET# inactive to BIT_CLK Startup delay	T _{rst2clk}	162.8	-	-	ns

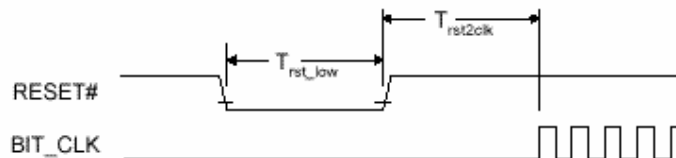

Cold reset timing diagram

7.2.2 Warm Reset

Parameter	Symbol	Minimum	Typical	Maximum	Units
SYNC active high pulse width	T_{sync_high}	1.0	-	-	μs
SYNC inactive to BIT_CLK Startup delay	$T_{sync2clk}$	162.8	-	-	ns

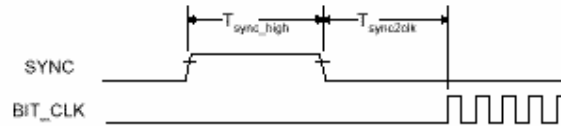

Warm reset timing diagram

7.2.3 AC-Link Clocks

The ALC650 derives its clock internally from an externally connected 24.576MHz crystal or an oscillator through the XTAL_IN pin. Synchronization with the AC'97 controller is achieved through the BIT_CLK pin at 12.288MHz (half of the crystal frequency).

The beginning of all audio sample packets, or "Audio Frames," transferred over AC-Link is synchronized to the rising edge of the "SYNC" signal driven by the AC'97 controller. Data is transitioned on AC-Link on every rising edge of BIT_CLK, and subsequently sampled by the receiving side on each immediately following falling edge of BIT_CLK.

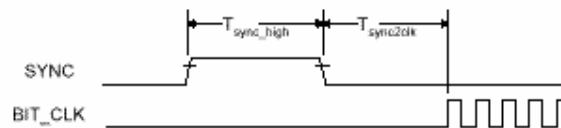

BIT_CLK and SYNC timing diagram

Parameter	Symbol	Minimum	Typical	Maximum	Units
BIT_CLK frequency		-	12.288	-	MHz
BIT_CLK period	T_{clk_period}	-	81.4	-	ns
BIT_CLK output jitter		-	500	750	ps
BIT_CLK high pulse width (note 1)	T_{clk_high}	36	40.7	45	ns
BIT_CLK low pulse width (note 1)	T_{clk_low}	36	40.7	45	ns
SYNC frequency		-	48.0	-	KHz
SYNC period	T_{sync_period}	-	20.8	-	μs
SYNC high pulse width	T_{sync_high}	-	1.3	-	μs
SYNC low pulse width	T_{sync_low}	-	19.5	-	μs

Note 1: Worse case duty cycle restricted to 45/55.

7.2.4 Data Output and Input Times

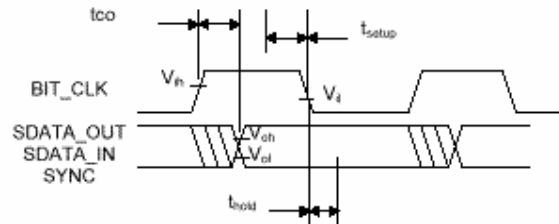

Data Output and Input timing diagram

Parameter	Symbol	Minimum	Typical	Maximum	Units
Output Valid Delay from rising edge of BIT_CLK	t_{co}	-	-	15	ns
Note 1: Timing is for SDATA and SYNC outputs with respect to BIT_CLK at the device driving the output.					
Note 2: 50pF external load					

Parameter	Symbol	Minimum	Typical	Maximum	Units
Input Setup to falling edge of BIT_CLK	t_{setup}	10	-	-	ns
Input Hold from falling edge of BIT_CLK	t_{hold}	10	-	-	ns
Note: Timing is for SDATA and SYNC outputs with respect to BIT_CLK at the device driving the output.					

Parameter	Symbol	Minimum	Typical	Maximum	Units
BIT_CLK combined rise or fall plus flight time		-	-	7	ns
SDATA combined rise or fall plus flight time		-	-	7	ns
Note: Combined rise or fall plus flight times are provided for worst case scenario modeling purpose.					

7.2.5 Signal Rise and Fall Times

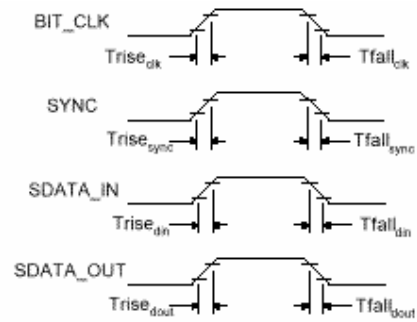

Signal Rise and Fall timing diagram

Parameter	Symbol	Minimum	Typical	Maximum	Units
BIT_CLK rise time	$T_{rise_{clk}}$	-	-	6	ns
BIT_CLK fall time	$T_{fall_{clk}}$	-	-	6	ns
SYNC rise time	$T_{rise_{sync}}$	-	-	6	ns
SYNC fall time	$T_{fall_{sync}}$	-	-	6	ns
SDATA_IN rise time	$T_{rise_{din}}$	-	-	6	ns
SDATA_IN fall time	$T_{fall_{din}}$	-	-	6	ns
SDATA_OUT rise time	$T_{rise_{dout}}$	-	-	6	ns
SDATA_OUT fall time	$T_{fall_{dout}}$	-	-	6	ns

Note 1: 75pF external load
 Note 2: rise is from 10% to 90% of Vdd (V_{ol} to V_{oh})
 Note 3: fall is from 90% to 10% of Vdd (V_{oh} to V_{ol})

7.2.6 AC-Link Low Power Mode Timing

The ALC650 AC-Link can be placed into low power mode by programming register 26h. Both BIT_CLK and SDATA_IN will be brought to and held at a logic low voltage level. The AC'97 controller can wake up the ALC650 by providing the proper reset signals.



AC-Link low power mode timing diagram

Parameter	Symbol	Minimum	Typical	Maximum	Units
End of slot 2 to BIT_CLK, SDATA_IN low	T_{s2_pdown}	-	-	1.0	μs

BIT_CLK and SDATA_IN are transitioned low immediately (within the maximum specified time) following the decode of the write to the Powerdown register (26h) with PR4. When the AC'97 controller driver is at the point where it is ready to program the AC-Link into its low power mode, slots 1 and 2 are assumed to be the only valid stream in the audio output frame after all audio sources have been neutralized. The AC'97 controller should also drive SYNC and SDATA_OUT low after changing the ALC650 to low power mode.

7.2.7 ATE Test Mode

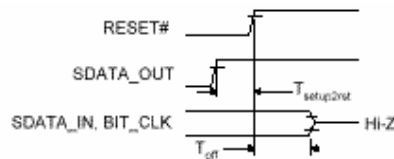

ATE test mode timing diagram

**To meet AC'97 Rev.2.2 requirements, EAPD, SPDIFO, BIT_CLK and SDATA_IN should be floating in test mode.*

Parameter	Symbol	Minimum	Typical	Maximum	Units
Setup to trailing edge of RESET# (also applies to SYNC)	$T_{setup2rst}$	15.0	-	-	ns
Rising edge of RESET# to Hi-Z delay	T_{off}	-	-	25.0	ns

All AC-Link signals are normally low through the trailing edge of RESET#. Asserting SDATA_OUT high for the trailing edge of RESET# causes the AC-Link outputs of the ALC650 to go to high impedance, which is suitable for ATE in circuit testing. Once either of the two test modes have been entered, the ALC650 must be issued another RESET# with all AC-Link signals low to return to normal operating mode.

7.2.8 AC-Link IO Pin Capacitance and Loading

Output Pin	1 CODEC	2 CODEC	3 CODEC	4 CODEC
BIT_CLK (must support ≥ 2 CODECs)	55pF	62.5pF	75pF	85pF
SDATA_IN	47.5pF	55pF	60pF	62.5pF

7.2.9 SPDIF Output

SPDIF_OUT	Minimum	Typical	Maximum	Unit
Rise time/fall time	0		10	%
Duty cycle	45		55	%

Note:

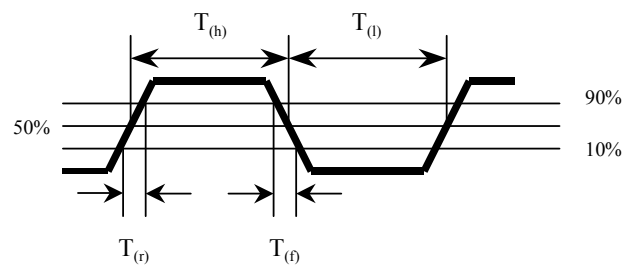

$$\begin{aligned} \text{Rise time} &= 100 * T_r / (T_l + T_h) \% \\ \text{Fall time} &= 100 * T_f / (T_l + T_h) \% \\ \text{Duty cycle} &= 100 * T_h / (T_l + T_h) \% \end{aligned}$$

7.2.10 BIT-CLK and SDATA-IN State

When RESET# is active, BIT-CLK and SDATA-IN must be floating by internal pull low 100K resistors. The ac-link signals are driven by another AC'97 on a CNR board. This requirement is not mentioned in the AC'97 specifications Rev 2.1. Please refer to CNR (Communication Network Riser) specifications Rev.1.0 pages 23~25 or AC'97 Rev.2.2 for detailed information.

8. Analog Performance Characteristics

Standard test condition: $T_{\text{ambient}}=25^{\circ}\text{C}$, $D_{\text{vdd}}=5.0$ or $3.3\text{V} \pm 5\%$, $A_{\text{vdd}}=5.0\text{V} \pm 5\%$

Input Voltage Level: Logic Low= $0.35 \times V_{\text{dd}}$, Logic High= $0.65 V_{\text{dd}}$

1KHz input sine wave; Sampling frequency=48KHz; 0dB=1Vrms

10K Ω /50pF load; Test bench characterization BW:20Hz~20KHz

0dB attenuation; tone and 3D disabled

Parameter	Minimum	Typical	Maximum	Units
Full scale input voltage				
Mixer (except for MIC)	-	1.6	-	Vrms
Mic input (gain=0dB)	-	1.6	-	Vrms
Mic input (gain=20dB)	-	0.16	-	Vrms
ADC	-	1.0	-	Vrms
Full scale output voltage				
Front DAC	-	1.5	-	Vrms
Front DAC (F version)	-	1.1	-	Vrms
Surround DAC, Center/LFE DAC	-	1.1	-	Vrms
S/N (A weighted)				
Analog Inputs to LINE_OUT	-	95	-	dB FSA
ADC	-	85	-	dB FSA
DAC (Front DAC with headphone amp)	-	85	-	dB FSA
DAC (Surround, Center, LFE DAC)	-	90	-	dB FSA
THD+N				
Analog Inputs to LINE_OUT	-	-85	-	dB FS
ADC	-	-80	-	dB FS
DAC (Front DAC with headphone amp)	-	-75	-	dB FS
DAC (Surround, Center, LFE DAC)	-	-80	-	dB FS
Frequency Response				
Mixers	10	-	22,000	Hz
ADC, DAC	16	-	19,200	Hz
Power Supply Rejection (DAC, ADC)	-	-68	-	dB
Total Out-of-Band Noise (28.8K~100KHz)	-	-63	-	dB
Mic 20dB gain is selected	18	20	22	dB
Crosstalk between inputs channels	-	-70	-	dB
Attenuation, Gain Step Size	-	1.5	-	dB
Input impedance (gain=0dB)				
MIC1, MIC2, PCBEEP, PHONE	-	16	-	K Ω
Others (LINE,CD,AUX,VIDEO)	-	32	-	K Ω
ADC	-	32	-	K Ω
Power Supply Current (normal operation)				
VA=5V / VD=3.3V	-	88 / 36	-	mA
VA=3.3V / VD=3.3V	-	71 / 36	-	mA
Power Supply Current (power down mode)				
VA=5V / VD=3.3V	-	0.5 / 10	-	mA
VA=3.3V / VD=3.3V	-	0.2 / 10	-	mA
Vrefout	2.25	2.50	2.75	V
Digital Filter Characteristics				
ADC Lowpass Filter				
Passband	0	-	19.2	KHz
Stopband	28.8	-	-	KHz
Stopband Rejection	-	-76.0	-	dB
Passband Frequency Response	-	+/- 0.15	-	dB
DAC Lowpass Filter				
Passband	0	-	19.2	KHz
Stopband	28.8	-	-	KHz
Stopband Rejection	-	-78.5	-	dB
Passband Frequency Response	-	+/- 0.15	-	dB

9. Design Suggestions

9.1 Clocking

The clock source for different configurations are listed below:

CODEC ID[1:0]	BIT-CLK	Clock source
00	Output	Crystal or external clock (XTAL-IN) BCLK is output
01,10,11	--	Not supported

9.2 AC-Link

When the ALC650 takes serial data from the AC'97 controller, it samples **SDATA_OUT** on the falling edge of **BIT_CLK**. When the ALC650 sends serial data to the AC'97 controller, it starts to drive **SDATA_IN** on the rising edge of **BIT_CLK**.

The ALC650 will return any uninstalled bits or registers with 0 for the read operation. The ALC650 also stuffs the unimplemented slot or bit with 0 in **SDATA-IN**. Note that AC-LINK is MSB-justified.

Refer to "Audio CODEC '97 Component Specification Revision 2.1" for details. Fig 7.2-1 is the 5.1 channel slot arrangement as defined in the AC'97 specifications Rev.2.1. Fig 7.2-2 shows the default slot mapping by different ID configurations of ALC650.

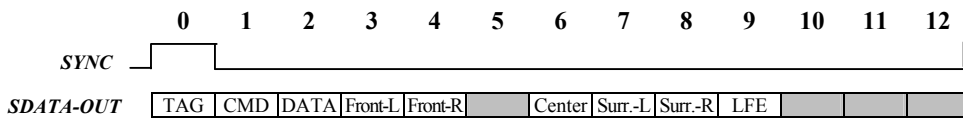

Fig7.2-1 5.1 channel slot arrangement defined in AC'97 specification rev2.1

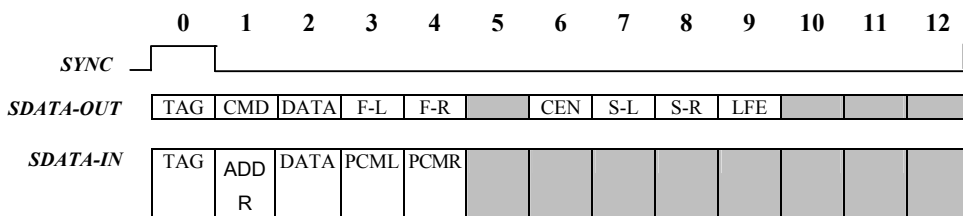

Fig7.2-2 Default ALC650 slot arrangement – CODEC ID = 00

- *F-L: Front DAC Left Out
- F-R: Front DAC Right Out
- S-L: Surround DAC Left Out
- S-R: Surround DAC Right Out
- CEN: Center DAC
- LFE: Low Frequency Effect DAC
- PCML: ADC Left Input
- PCMR: ADC Right Input

9.3 Reset

There are 3 kinds of reset operation. *Cold*, *Warm* and *Register* reset which listed below:

Reset Type	Trigger condition	CODEC response
Cold	Assert RESET# for a specified period	Reset all hardware logic and all registers to their default values
Register	Write register indexed 00h	Reset all registers to their default values
Warm	Driven SYNC high for specified period without BIT_CLK	Reactivates AC-LINK, no change to register values

The AC'97 controller should drive SYNC and SDATA-OUT low during the period of RESET# assertion to guarantee a successful reset of the ALC650.

9.4 CD Input

It is crucial to take notice of differential CD Input. Below is an example of differential CD input.

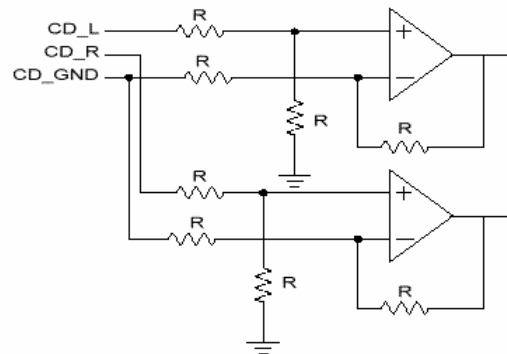

Example of differential CD input

9.5 Odd Addressed Register Access

The ALC650 will return "0000h" when odd-addressed registers and unimplemented registers are read.

9.6 Power-down Mode

Pay special attention to powerdown control register (index 26h), especially PR4 (power-down AC-link)

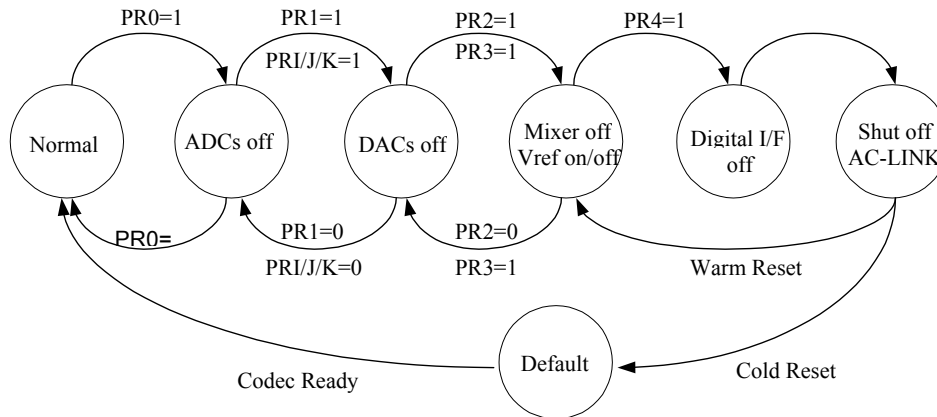

Example of ALC650 power-down/power-up flow

9.7 Test Mode

The ALC650 has two test modes. One is for ATE in circuit test and the other is for vendor specific tests. All AC-link signals are normally low through the trailing edge of RESET#. When coming out of RESET, an AC'97 CODEC enters the ATE in circuit test mode if SDATA_OUT is sampled high at the trailing edge of RESET#, and enters the vendor specific test mode if SYNC is sampled high at the trailing edge of RESET#. Note that the ALC650 Rev. E does not support vendor specific test mode.

These cases will never occur during standard operating conditions.

Regardless of the test mode, the ALC650 will issue a cold reset to resume normal operation.

SYNC	SDATA_OUT	Description
0	0	Normal operation
0	1	ATE Test Mode
1	0	Vendor Test Mode
1	1	Reserved

9.7.1 ATE In Circuit Test Mode

SDATA_OUT is sampled high at the trailing edge of RESET#. In this mode, the ALC650 will drive BIT_CLK, SDATA_IN, EAPD and SPDIFO to high impedance.

9.7.2 Vendor Specific Test Mode

SYNC is sampled high at the trailing edge of RESET#. In this mode, the ALC650 will drive BIT_CLK, SDATA_IN, EAPD and SPDIFO to high impedance.

Note: To attain closest compatibility with AC'97 rev2.2, the ALC650 will float its digital output pins in both ATE and Vendor-Specific test modes. Please refer to AC'97 rev2.2 section 9.2 for detail description about test mode.

10. Application Circuits

R47, R49 and C14 can bias external clock to acceptable level once the driving strength of external clock is weak.

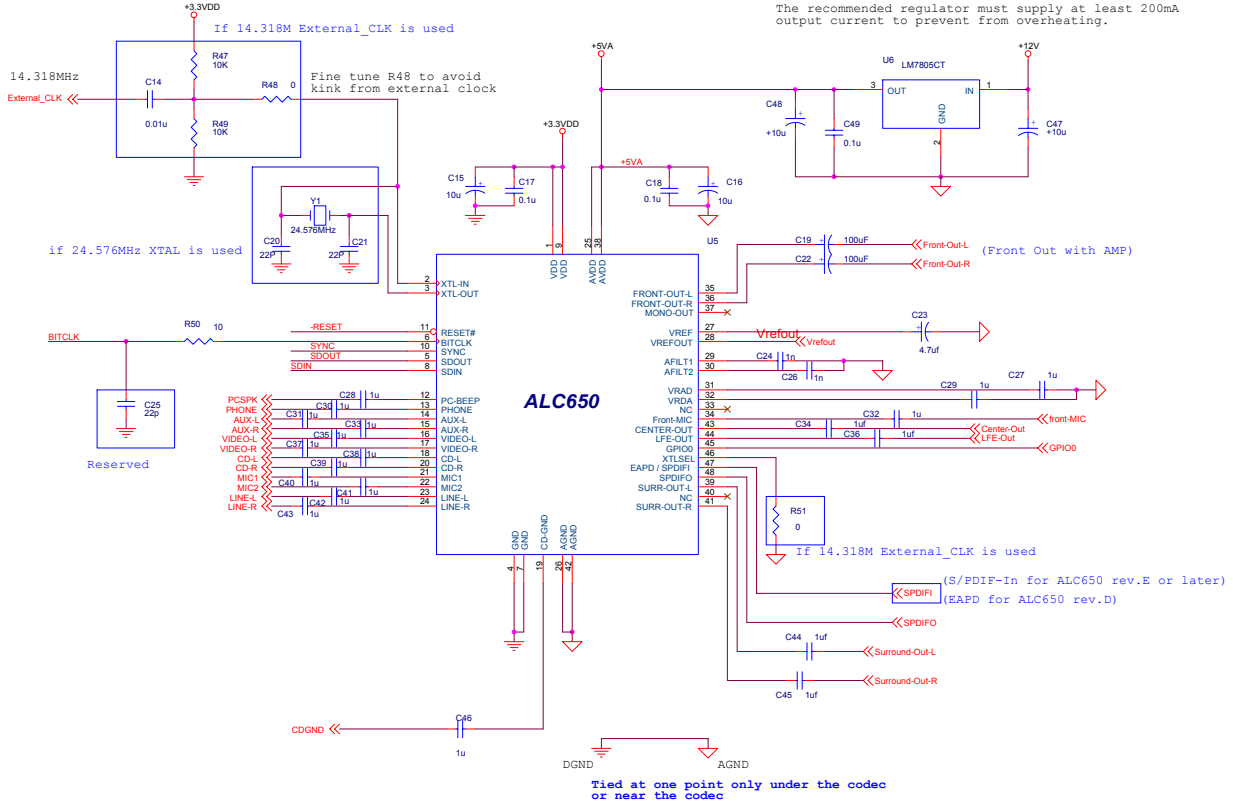

Example of Circuit Layout

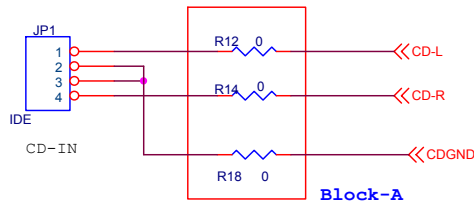

****Those resistors in Block-A are used to fine-tune performance, system designer had better keep those resistors.**

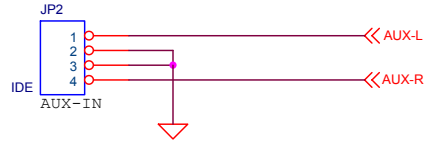

If LINE-IN is designed to be shared with Surround-Out, keep 2/3 are floated

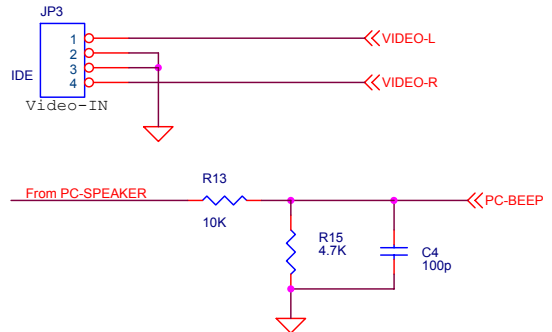
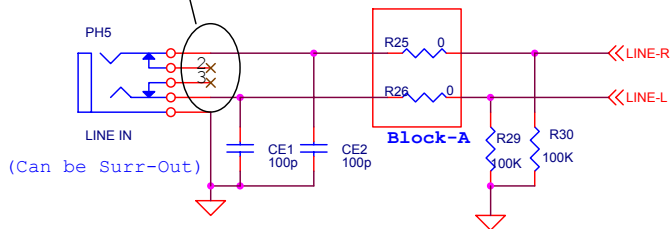

option 1: For ALC650 rev.D, select this bias circuit to share MIC-In and CEN/LFE-Out

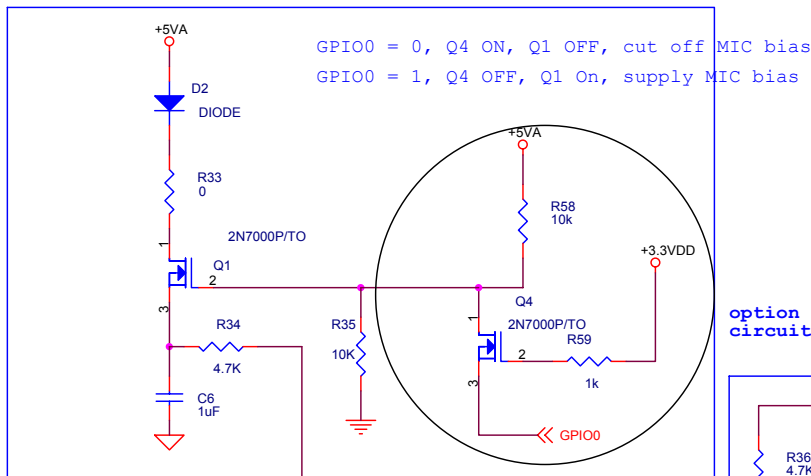

option 2: For ALC650 rev.E, select this bias circuit to share MIC-In and CEN/LFE-Out

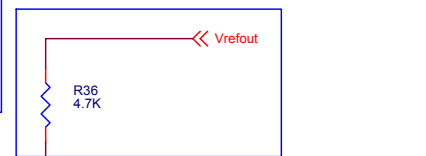

If MIC-IN is designed to be shared with CEN/LFE-Out, keep 2/3 are floated



Analog I/O connection of the ALC650

(R16, R17 not mounted if front panel header mounted)

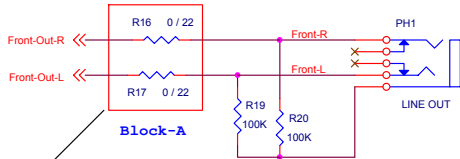

If AVDD is supplied by 78L05 has only 100mA current, change R16 and R17 to 20ohm to limit current consumption.

Block-A: to fine tune performance, system designer had better keep those resistors.

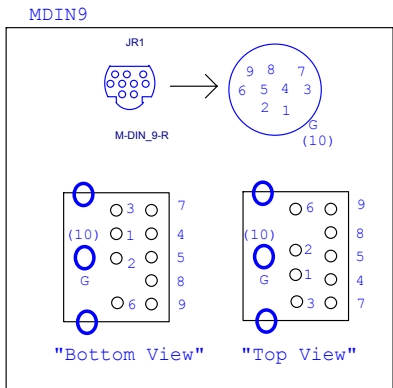
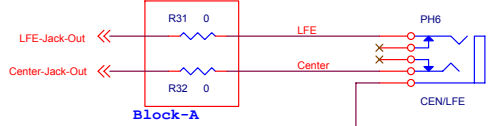
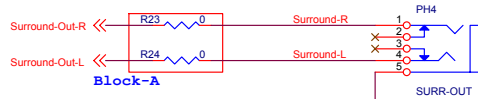

Block-B (Front panel header)

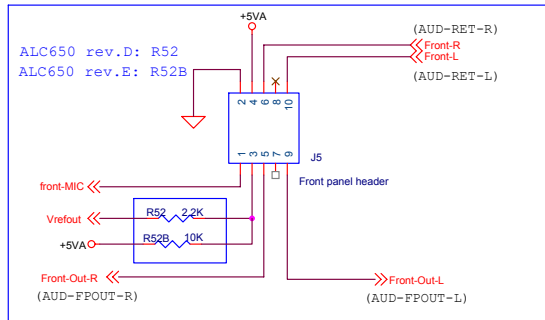

Block-C (6 channel analog output in Mini Din connector)

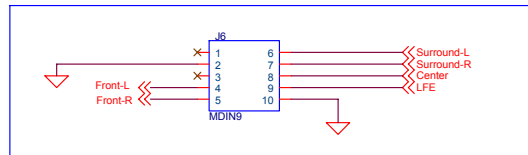

Block-D (Option: for different definition about LFE and Center) (ALC650 rev.E can switch LFE and Center output, this block can be eliminated.)

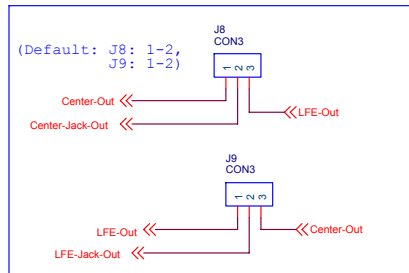

Multi-Channel Analog I/O connection of the ALC650

Option (I): S/PDIF signal use RCA connector
 + Line Driver/ Receiver (is suitable for long transmission line)

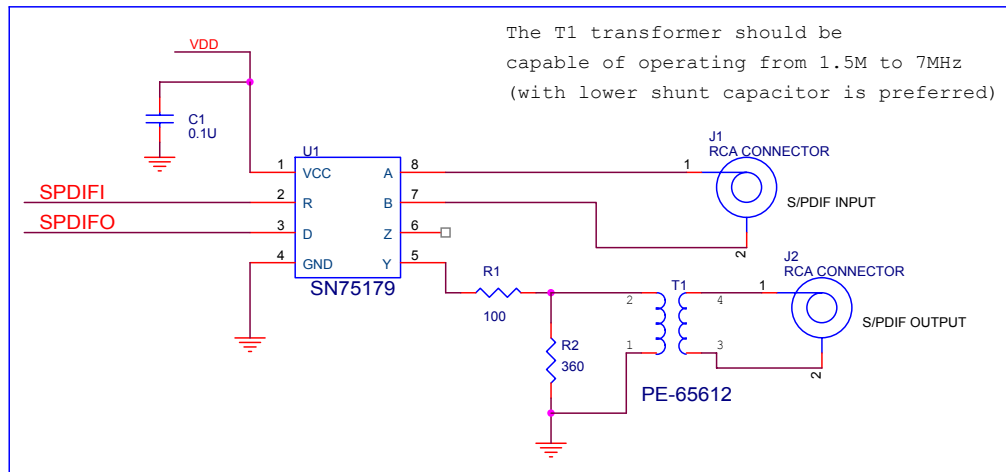

Option (II): S/PDIF signal use fiber optic transmitter and receiver module

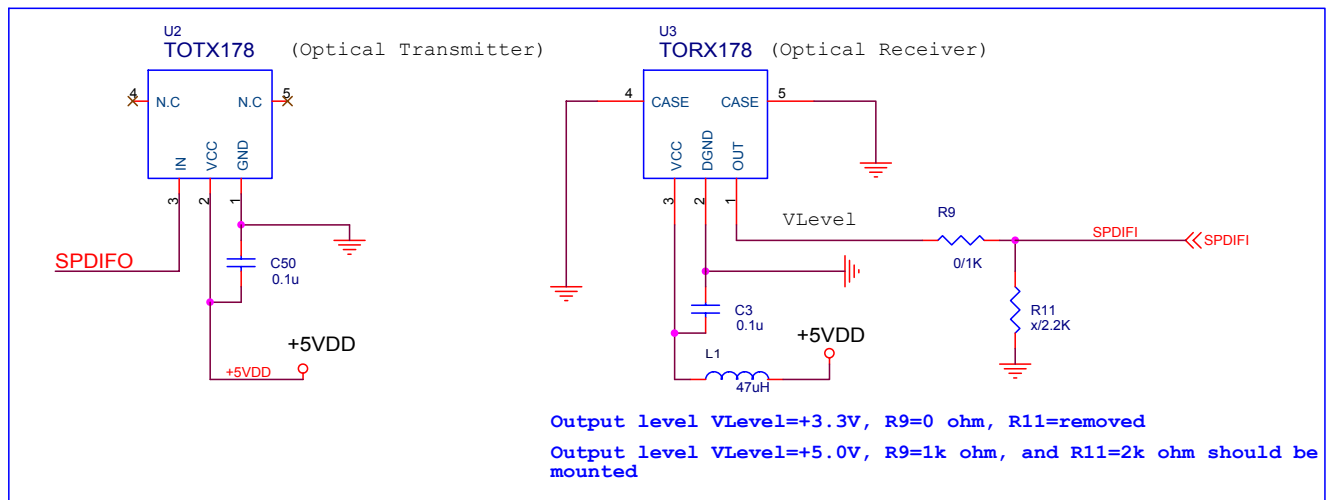

Option (III): Without Line Driver/ Receiver
 Use R3 and R8: Guaranteed transmission distance <= 7 feet
 Use T1,R5,R6: At least 10 feet of transmission distance

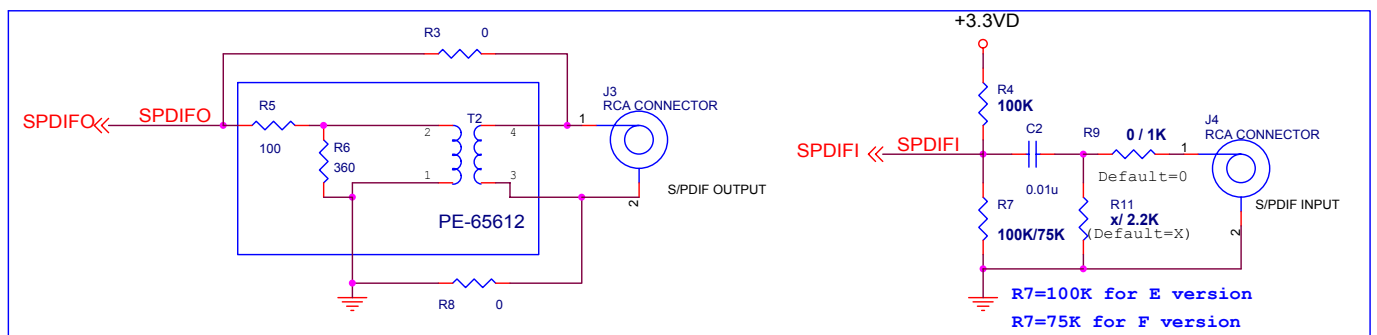

Optional SPDIF Input/Output Connection (S/PDIF-In is only for the ALC650 Rev. E or later)

11. Mechanical Dimensions

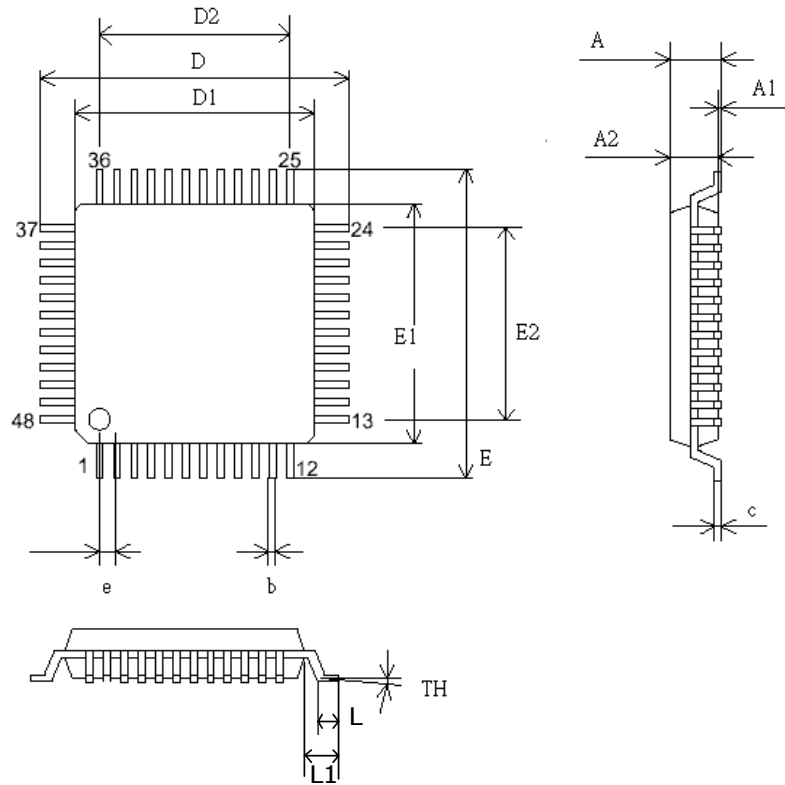

SYMBOL	MILLIMETER			INCH		
	MIN.	TYPICAL	MAX.	MIN.	TYPICAL	MAX.
A			1.60			0.063
A1	0.05		0.15	0.002		0.006
A2	1.35	1.40	1.45	0.053	0.055	0.057
C	0.09		0.20	0.004		0.008
D	9.00 BSC			0.354 BSC		
D1	7.00 BSC			0.276 BSC		
D2	5.50			0.217		
E	9.00 BSC			0.354 BSC		
E1	7.00BSC			0.276 BSC		
E2	5.50			0.217		
b	0.17	0.20	0.27	0.007	0.008	0.011
e	0.50 BSC			0.016 BSC		
TH	0°	3.5°	7°	0°	3.5°	7°
L	0.45	0.60	0.75	0.018	0.0236	0.030
L1		1.00			0.0393	

TITLE: LQFP-48 (7.0x7.0x1.6mm)		
PACKAGE OUTLINE DRAWING, FOOTPRINT 2.0mm		
LEADFRAME MATERIAL		
APPROVE	DOC. NO.	
	VERSION	02
CHECK	DWG NO.	PKG-065
	DATE	
REALTEK SEMICONDUCTOR CORP.		

12. Ordering Information

Part Number	Package	Status
ALC650-VF	48-pin LQFP. Standard product	
ALC650-VF-LF	ALC650-VF + Lead (Pb)-Free package	

Note: Above parts are tested under AVDD = 5.0V. If customers have lower AVDD request, please contact Realtek sales representatives or agents.

Realtek Semiconductor Corp.

Headquarters

No. 2, Innovation Road II

Hsinchu Science Park, Hsinchu 300, Taiwan

Tel.: +886-3-578-0211. Fax: +886-3-577-6047

www.realtek.com.tw