

ASSP

BIPOLAR

Switching Regulator Controller

(4 Channels plus High-Precision, High-Frequency Capabilities)

MB3785A

■ DESCRIPTION

The MB3785A is a PWM-based 4-channel switching regulator controller featuring high-precision, high-frequency capabilities. All of the four channels of circuits allow their outputs to be set in three modes: step-down, step-up, and inverted. The third and fourth channels are suited for DC motor speed control.

The triangular-wave oscillation circuit accepts a ceramic resonator, in addition to the standard method of oscillation using an RC network.

■ FEATURES

- Wide range of operating power supply voltages: 4.5 V to 18 V
- Low current consumption: 6 mA [TYP] when operating 10 μ A or less during standby
- Built-in high-precision reference voltage generator: 2.50 V \pm 1%
- Oscillation circuit
 - Capable of high-frequency oscillation: 100 kHz to 1 MHz
 - Also accepts a ceramic resonator.
- Wide input range of error amplifier: -0.2 V to $V_{CC}-1.8$ V
- Built-in timer/latch-actuated short-circuiting detection circuit

(Continued)

■ PACKAGE

48-pin, Plastic LQFP

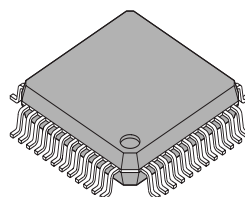

(FPT-48P-M05)

MB3785A

(Continued)

- Output circuit
 - The drive output for PNP transistors is the totem-pole type allowing the on-current and off-current values to be set independently.
- Adjustable dead time over the entire duty ratio range
- Built-in standby and output control functions
- High-density mounting possible: 48-pin LQFP package

■ PIN ASSIGNMENT

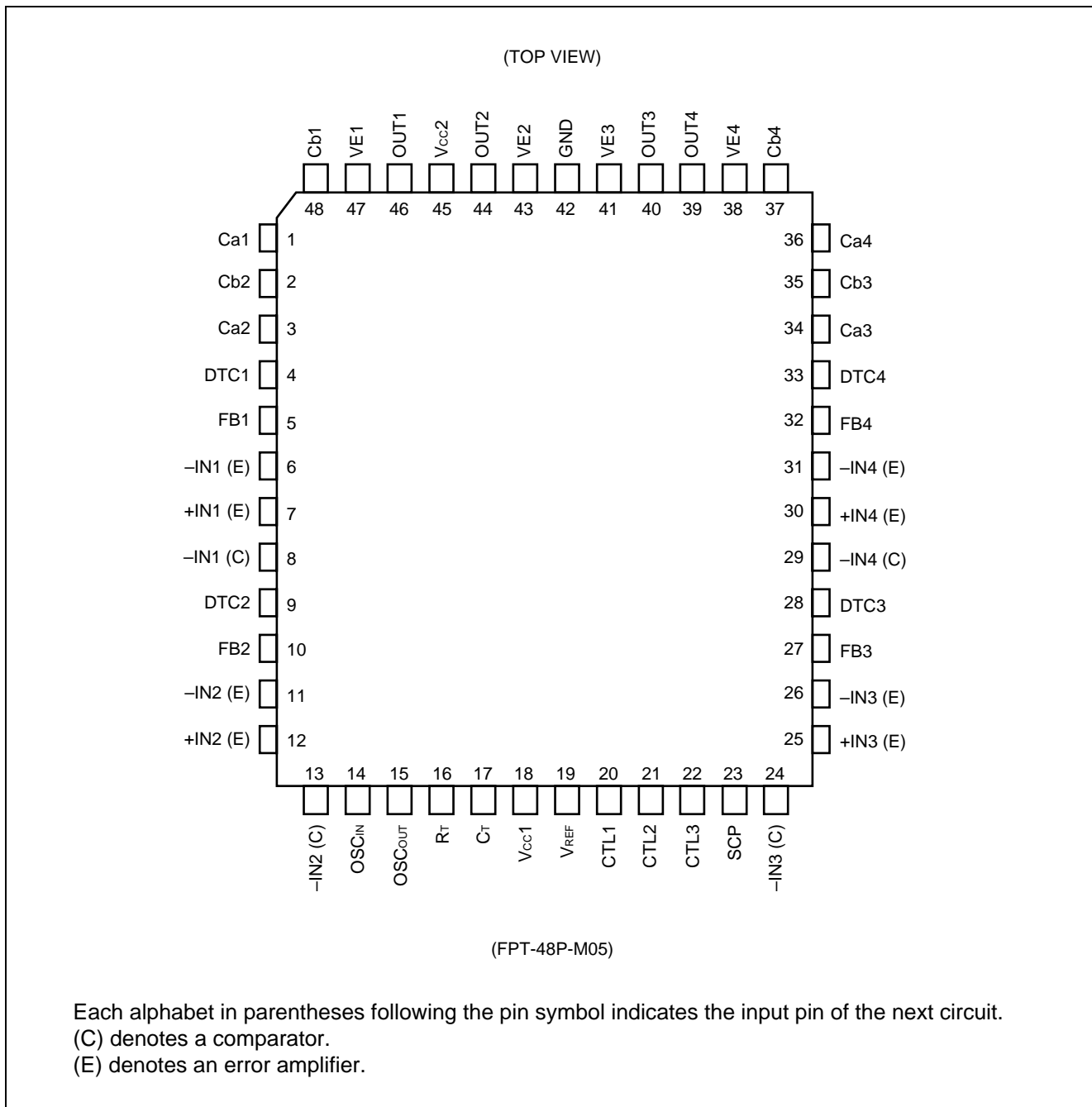

■ PIN DESCRIPTION

| Pin No. | Symbol | I/O | Description |
|---------|--------|------------------------------|---|
| CH1 | 1 | Ca1 | — CH1 output transistor OFF-current setting pin. Insert a capacitor between the Ca1 and the Cb1 pins, then set the output transistor OFF-current. |
| | 48 | Cb1 | |
| | 7 | +IN1(E) | I CH1 error amp non-inverted input pin. |
| | 6 | -IN1(E) | I CH1 error amp inverted input pin. |
| | 5 | FB1 | O CH1 error amp output pin. |
| | 8 | -IN1(C) | I CH1 comparator inverted input pin. |
| | 4 | DTC1 | I CH1 dead time control pin. |
| | 47 | VE1 | I CH1 output current setting pin. |
| | 46 | OUT1 | O CH1 totem-pole output pin. |
| CH2 | 3 | Ca2 | — CH2 output transistor OFF-current setting pin. Insert a capacitor between the Ca2 and the Cb2 pins, then set the output transistor OFF-current. |
| | 2 | Cb2 | |
| | 12 | +IN2(E) | I CH2 error amp non-inverted input pin. |
| | 11 | -IN2(E) | I CH2 error amp inverted input pin. |
| | 10 | FB2 | O CH2 error amp output pin. |
| | 13 | -IN2(C) | I CH2 comparator inverted input pin. |
| | 9 | DTC2 | I CH2 dead time control pin. |
| | 43 | VE2 | I CH2 output current setting pin. |
| 44 | OUT2 | O CH2 totem-pole output pin. | |
| CH3 | 34 | Ca3 | — CH3 output transistor OFF-current setting pin. Insert a capacitor between the Ca3 and the Cb3 pins, then set the output transistor OFF-current. |
| | 35 | Cb3 | |
| | 25 | +IN3(E) | I CH3 error amp non-inverted input pin. |
| | 26 | -IN3(E) | I CH3 error amp inverted input pin. |
| | 27 | FB3 | O CH3 error amp output pin. |
| | 24 | -IN3(C) | I CH3 comparator inverted input pin. |
| | 28 | DTC3 | I CH3 dead time control pin. |
| | 41 | VE3 | I CH3 output current setting pin. |
| | 40 | OUT3 | O CH3 totem-pole output pin. |
| CH4 | 36 | Ca4 | — CH4 output transistor OFF-current setting pin. Insert a capacitor between the Ca4 and the Cb4 pins, then set the output transistor OFF-current. |
| | 37 | Cb4 | |
| | 30 | +IN4(E) | I CH4 error amp non-inverted input pin. |
| | 31 | -IN4(E) | I CH4 error inverted input pin. |
| | 32 | FB4 | O CH4 error amp output pin. |
| | 29 | -IN4(C) | I CH4 comparator inverted input pin. |

(Continued)

MB3785A

(Continued)

| Pin No. | Symbol | I/O | Description | |
|------------------------------------|--------|--------------------|-------------|---|
| CH4 | 33 | DTC4 | I | CH4 dead time control pin. |
| | 38 | VE4 | I | CH4 output current setting pin. |
| | 39 | OUT4 | O | CH4 totem-pole output pin. |
| Triangular-Wave Oscillator Circuit | 14 | OSC _{IN} | — | This pin connects a ceramic resonator. |
| | 15 | OSC _{OUT} | — | |
| | 16 | R _T | — | This pin connects to a resistor for setting the triangular-wave frequency. |
| | 17 | C _T | — | This pin connects to a capacitor for setting the triangular-wave frequency. |
| Power Supply Circuit | 18 | V _{CC1} | — | Power supply pin for the reference power supply control circuit. |
| | 45 | V _{CC2} | — | Power supply pin for the output circuit. |
| | 42 | GND | — | GND pin. |
| | 19 | V _{REF} | O | Reference voltage output pin. |
| Control Circuit | 23 | SCP | — | This pin connects to a capacitor for the short-circuit protection circuit. |
| | 20 | CTL1 | I | Power supply circuit and first-channel control pin. When this pin is High, the power supply circuit and first channel are in active state. When this pin is Low, the power supply circuit and first channel are in standby state. |
| | 21 | CTL2 | I | Second-channel control pin. While the CTL1 pin is High When this pin is High, the second channel is in active state. When this pin is Low, the second channel is in the inactive state. |
| | 22 | CTL3 | I | Third and fourth-channel control pin. While the CTL1 pin is High When this pin is High, the third and fourth channels are in active state. When this pin is Low, the third and fourth channels are in the inactive state. |

■ BLOCK DIAGRAM

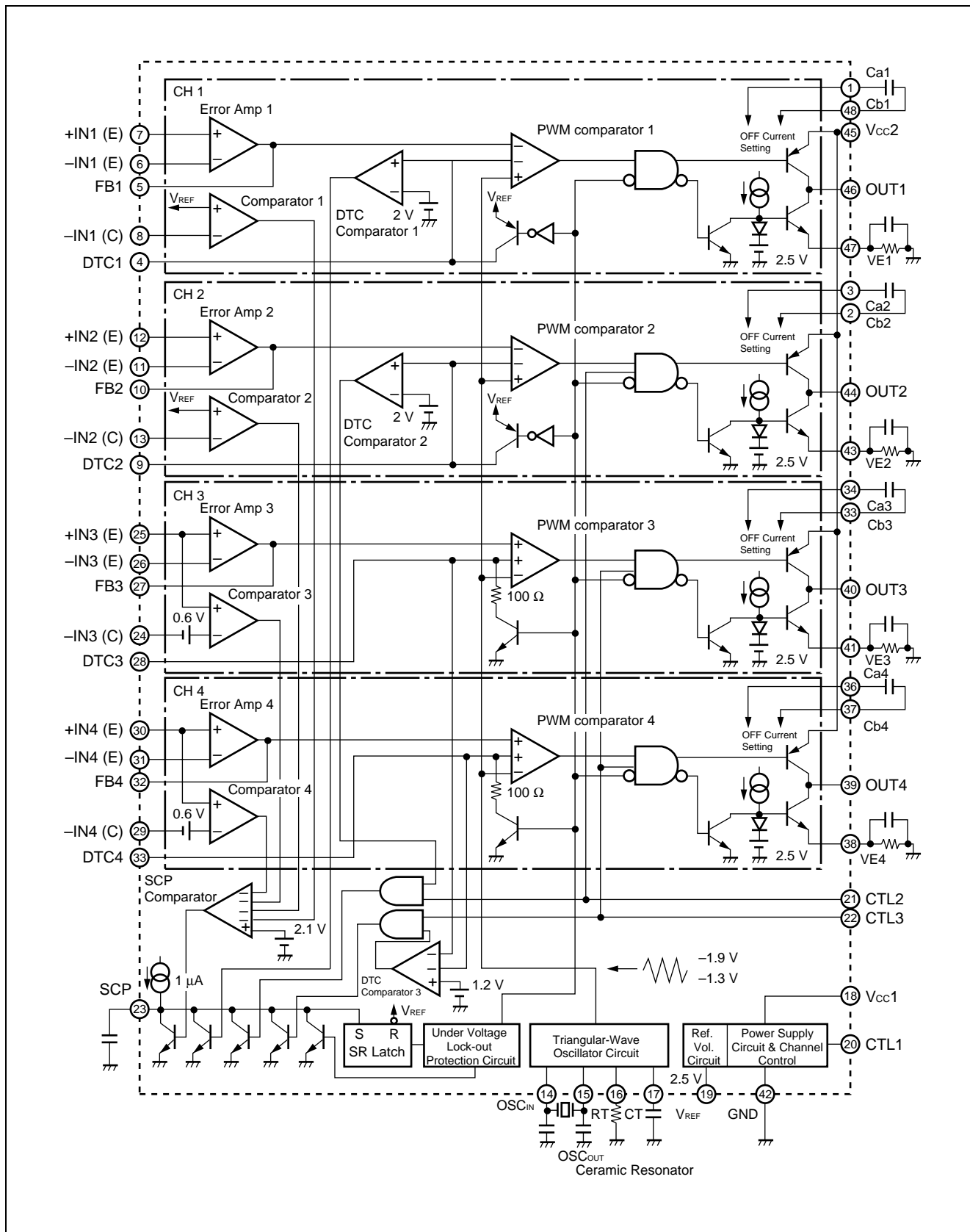

■ FUNCTIONAL DESCRIPTION

1. Switching Regulator Function

(1) Reference voltage circuit

The reference voltage circuit generates a temperature-compensated reference voltage ($\cong 2.50$ V) using the voltage supplied from the power supply terminal (pin 18). This voltage is used as the operating power supply for the internal circuits of the IC. The reference voltage can also be supplied to an external device from the V_{REF} terminal (pin 19).

(2) Triangular-wave oscillator circuit

By connecting a timing capacitor and a resistor to the C_T (pin 17) and the R_T (pin 16) terminals, it is possible to generate any desired triangular oscillation waveform. The oscillation can also be obtained by using a ceramic resonator connected to pins 14 and 15.

This waveform has an amplitude of 1.3 V to 1.9 V and is input to the internal PWM comparator of the IC. At the same time, it can also be supplied to an external device from the C_T terminal (pin 17).

(3) Error amplifier

This amplifier detects the output voltage of the switching regulator and outputs a PWM control signal accordingly. It has a wide common-mode input voltage range from -0.2 V to $V_{CC} - 1.8$ V and allows easy setting from an external power supply, making the system suitable for DC motor speed control.

By connecting a feedback resistor and capacitor from the error amplifier output pin to the inverted input pin, you can form any desired loop gain, for stable phase compensation.

(4) PWM comparator

- CH1 & CH2

The PWM comparators in these channels are a voltage comparator with two inverted input and one non-inverted input, that is, a voltage-pulse width converter to control the output pulse on-time according to the input voltage. It turns on the output transistor when the triangular wave from the oscillator is higher than both the error amplifier output and the DTC-pin voltages.

- CH3 & CH4

The PWM comparators in these channels are a voltage comparator with one inverted input and two non-inverted inputs, that is, a voltage-pulse width converter to control the output pulse on-time according to the input voltage. It turns on the output transistor when the triangular wave from the oscillator is lower than both the error amplifier output and the DTC-pin voltages.

These four channels can be provided with a soft start function by using the DTC pin.

(5) Output circuit

The output circuit is comprised of a totem-pole configuration and can drive a PNP transistor (30 mA max.)

2. Channel Control Function

The MB3785A allows the four channels of power supply circuits to be controlled independently. Set the voltage levels on the CTL1 (pin 20), CTL2 (pin 21), and CTL3 (pin 22) terminals to turn the circuit of each channel “ON” or “OFF”, as listed below.

Table 1 Channel by Channel On/Off Setting Conditions.

| CTL pin voltage level | | | On/Off state of channel | | | |
|-----------------------|------|------|-------------------------|---------------|----------------|----------------------|
| CTL1 | CTL2 | CTL3 | Power supply circuit | First channel | Second channel | 3rd and 4th channels |
| H | H | H | ON | | ON | ON |
| | | L | | | | OFF |
| | L | H | | | OFF | ON |
| | | L | | | | OFF |
| L | X | | Standby state* | | | |

* : The power supply current value during standby is 10 μ A or less.

3. Protective Functions

(1) Timer/latch-actuated short-circuiting protection circuit

The SCP comparator checks the output voltage of each comparator which is used to detect the short-circuiting of output. When any of these comparators have an output voltage greater than or equal to 2.1 V, the timer circuit is activated and a protection enable capacitor externally fitted to the SCP terminal (pin 23) begins to charge.

If the comparator's output voltage is not restored to normal voltage level by the time the capacitor voltage has risen to the base-emitter junction voltage of the transistor, i.e., V_{BE} (\cong 0.65 V), the latch circuit is activated to turn off the output transistor while at the same time setting the duty (OFF) = 100 %.

When actuated, this protection circuit can be reset by turning on the power supply again.

(2) Under voltage lockout protection circuit

A transient state at power-on or a momentary drop of the power supply voltage causes the control IC to malfunction, resulting in system breakdown or deterioration. By detecting the internal reference voltage with respect to the power supply voltage, this protection circuit resets the latch circuit to turn off the output transistor and set the duty (OFF) = 100 %, while at the same time holding the SCP terminal (pin 23) at the “L”. The reset is cleared when the power supply voltage becomes greater than or equal to the threshold voltage level of this protection circuit.

MB3785A

■ ABSOLUTE MAXIMUM RATINGS (See WARNING)

(Ta = +25°C)

| Parameter | Symbol | Conditions | Rating | Unit |
|-------------------------------|-------------------|------------|------------|------|
| Power supply voltage | V _{CC} | — | 20 | V |
| Control input voltage | V _{ICTL} | — | 20 | V |
| Power dissipation | P _D | Ta ≤ +25°C | 550* | mW |
| Operating ambient temperature | T _{OP} | — | -30 to 85 | °C |
| Storage temperature | T _{stg} | — | -55 to 125 | °C |

* : The packages are mounted on the epoxy board (4 cm × 4 cm).

WARNING: Permanent device damage may occur if the above **Absolute Maximum Ratings** are exceeded. Functional operation should be restricted to the conditions as detailed in the operational sections of this data sheet. Exposure to absolute maximum rating conditions for extended periods may affect device reliability.

■ RECOMMENDED OPERATING CONDITIONS

(Ta = +25°C)

| Parameter | Symbol | Conditions | Value | | | Unit |
|-------------------------------|-------------------|------------|-------|------|-----------------------|------|
| | | | Min. | Typ. | Max. | |
| Power supply voltage* | V _{CC} | — | 4.5 | 6.0 | 18 | V |
| Error amp. input voltage | V _I | — | -0.2 | — | V _{CC} - 0.8 | V |
| Comparator input voltage | V _I | — | -0.2 | — | V _{CC} | V |
| Control input voltage | V _{ICTL} | — | -0.2 | — | 18 | V |
| Output current | I _O | — | 3.0 | — | 30 | mA |
| Timing capacitance | C _T | — | 68 | — | 1500 | pF |
| Timing resistance | R _T | — | 5.1 | — | 100 | kΩ |
| Oscillation frequency | f _{OSC} | — | 100 | 500 | 1000 | kHz |
| Operating ambient temperature | T _{OP} | — | -30 | 25 | 85 | °C |

* : The minimum value of the recommended supply voltage is 3.6 V except when the device operates with constant output sink current.

■ ELECTRICAL CHARACTERISTICS

($V_{CC} = +6\text{ V}$, $T_a = +25^\circ\text{C}$)

| Parameter | | Symbol | Conditions | Value | | | Unit | |
|--|---|----------------------------------|--|--------------------|-----------|-------|---------------|----|
| | | | | Min. | Typ. | Max. | | |
| Reference voltage block | Reference voltage | V_{REF} | $I_{OR} = -1\text{ mA}$ | 2.475 | 2.500 | 2.525 | V | |
| | Rate of changed in output voltage vs. Temperature | $\frac{\Delta V_{REF}}{V_{REF}}$ | $T_a = -30^\circ\text{C to } +85^\circ\text{C}$ | -2 | ± 0.2 | 2 | % | |
| | Input stability | Line | $V_{CC} = 3.6\text{ V to } 18\text{ V}$ | -10 | -2 | 10 | mV | |
| | Load stability | Load | $I_{OR} = -0.1\text{ mA to } -1\text{ mA}$ | -10 | -3 | 10 | mV | |
| | Sort-circuit output current | I_{OS} | $V_{REF} = 2\text{ V}$ | -25 | -8 | -3 | mA | |
| Under voltage lockout protection circuit (U.V.L.O) | Threshold voltage | V_{IH} | — | — | 2.72 | — | V | |
| | | V_{IL} | — | — | 2.60 | — | V | |
| | Hysteresis width | V_{HYS} | — | 80 | 120 | — | mV | |
| | Reset voltage (V_{CC}) | V_R | — | 1.5 | 1.9 | — | V | |
| Short-circuit detection comparator | 1 CH/2 CH | Input threshold voltage | V_{th} | — | 2.45 | 2.50 | 2.55 | V |
| | | Input bias current | I_{IB} | $V_I = 0\text{ V}$ | -200 | -100 | — | nA |
| | | Input voltage range | V_I | — | -0.2 | — | V_{CC} | V |
| | 3 CH/4 CH | Input offset voltage | V_{IO} | — | 0.58 | 0.65 | 0.72 | V |
| | | Input bias current | I_{IB} | $V_I = 0\text{ V}$ | -200 | -100 | — | nA |
| | | Common mode input voltage range | V_{ICM} | — | -0.2 | — | $V_{CC}-1.8$ | V |
| Short circuit detection block | Threshold voltage | V_{IPC} | — | 0.60 | 0.65 | 0.70 | V | |
| | Input standby voltage | V_{STB} | — | — | 50 | 100 | mV | |
| | Input latch voltage | V_I | — | — | 50 | 100 | mV | |
| | Input source current | I_{Ibpc} | — | -1.4 | -1.0 | -0.6 | μA | |
| Triangular waveform oscillator block | Oscillation frequency | f_{OSC} | $C_T = 300\text{ pF}$, $R_T = 6.2\text{ k}\Omega$ | 450 | 500 | 550 | kHz | |
| | Frequency stability (V_{CC}) | $\Delta f/f_{dv}$ | $V_{CC} = 3.6\text{ V to } 18\text{ V}$ | — | ± 1 | — | % | |
| | Frequency stability (T_a) | $\Delta f/f_{dT}$ | $T_a = -30^\circ\text{C to } +85^\circ\text{C}$ | -4 | — | 4 | % | |

(Continued)

MB3785A

(Continued)

($V_{CC} = +6\text{ V}$, $T_a = +25^\circ\text{C}$)

| Parameter | Symbol | Conditions | Value | | | Unit | |
|-------------------------------------|---------------------------------|------------|-----------------------------------|---------------|------|--------------|---------------|
| | | | Min. | Typ. | Max. | | |
| Error amplifier | Input offset voltage | V_{IO} | $V_{FB} = 1.6\text{ V}$ | -10 | — | 10 | mV |
| | Input bias current | I_{IB} | $V_{FB} = 1.6\text{ V}$ | -200 | -100 | — | nA |
| | Common mode input voltage range | V_{ICM} | — | -0.2 | — | $V_{CC}-1.8$ | V |
| | Voltage gain | A_V | — | 60 | 100 | — | dB |
| | Frequency bandwidth | BW | $A_V = 0\text{ dB}$ | — | 800 | — | kHz |
| 1 CH/2 CH dead time control circuit | Input threshold voltage | V_{t0} | Duty cycle = 0 % | — | 1.9 | 2.25 | V |
| | | V_{t100} | Duty cycle = 100 % | 1.05 | 1.3 | — | V |
| | Input bias current | I_{lbt} | $V_{dt} = 2.3\text{ V}$ | — | 0.1 | 0.5 | μA |
| | Latch mode source current | I_{ldt} | $V_{dt} = 1.5\text{ V}$ | — | -500 | -80 | μA |
| | Latch input voltage | V_{ldt} | $I_{dt} = -40\text{ }\mu\text{A}$ | $V_{REF}-0.3$ | 2.4 | — | V |
| 3 CH/4 CH dead time control circuit | Input threshold voltage | V_{t0} | Duty cycle = 0 % | 1.05 | 1.3 | — | V |
| | | V_{t100} | Duty cycle = 100 % | — | 1.9 | 2.25 | V |
| | Input bias current | I_{lbt} | $V_{dt} = 2.3\text{ V}$ | — | 0.1 | 0.5 | μA |
| | Latch mode source current | I_{ldt} | $V_{dt} = 1.5\text{ V}$ | 80 | 500 | — | μA |
| | Latch input voltage | V_{ldt} | $I_{dt} = +40\text{ }\mu\text{A}$ | — | 0.2 | 0.3 | V |
| Channel control block | Threshold voltage | V_{th} | — | 0.7 | 1.4 | 2.1 | V |
| | Input current | I_{IH} | $V_{CTL} = 5\text{ V}$ | — | 100 | 200 | μA |
| | | I_{IL} | $V_{CTL} = 0\text{ V}$ | -10 | — | 10 | μA |
| Output block | Source current | I_o | — | — | -40 | — | mA |
| | Sink current | I_o | $R_E = 82\text{ }\Omega$ | 18 | 30 | 42 | mA |
| | Output leakage current | I_{LO} | $V_o = 18\text{ V}$ | — | — | 20 | μA |
| General | Standby current | I_{CC0} | — | — | 0 | 10 | μA |
| | Supply current when output off | I_{CC} | — | — | 6 | 8.6 | mA |

TYPICAL CHARACTERISTIC CURVES

1. Supply current vs. Supply voltage

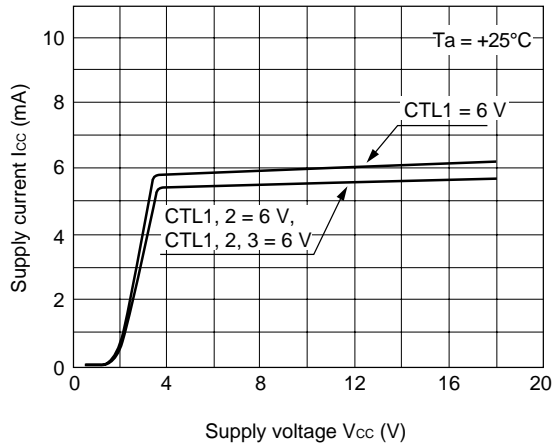

2. Reference voltage vs. Supply voltage

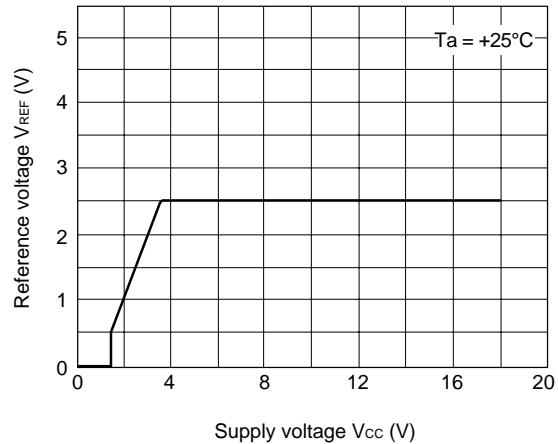

3. Reference voltage and Output current setting pin voltage vs. Supply voltage

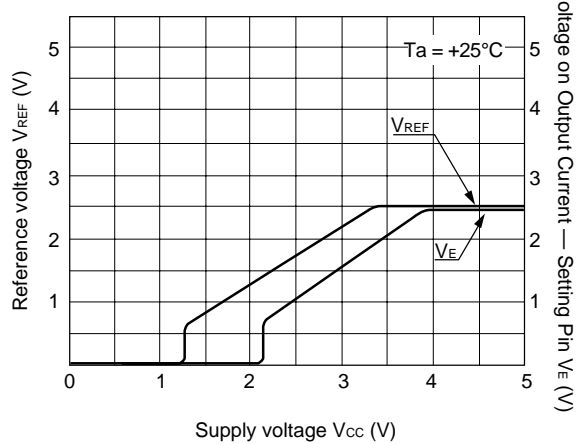

4. Reference voltage vs. Ambient temperature

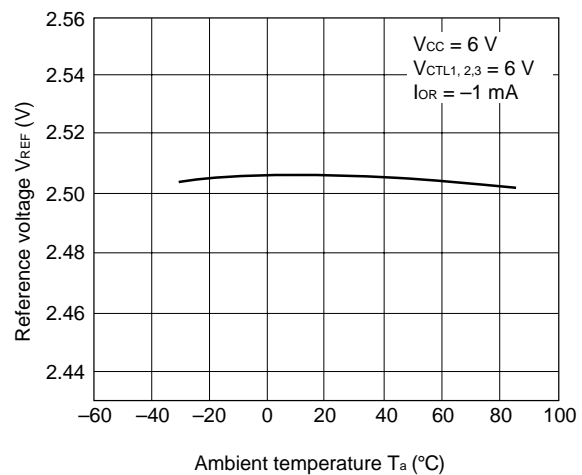

5. Reference voltage vs. Control voltage

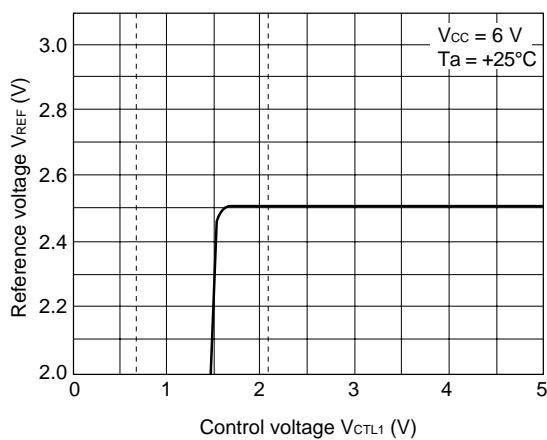

6. Control current vs. Control voltage

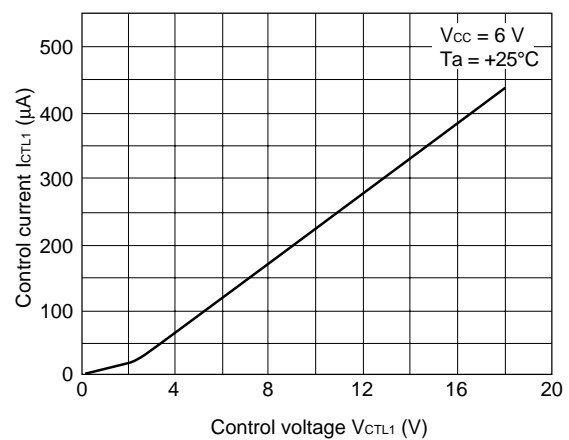

(Continued)

(Continued)

7. Triangular wave maximum amplitude voltage vs. Timing capacitance

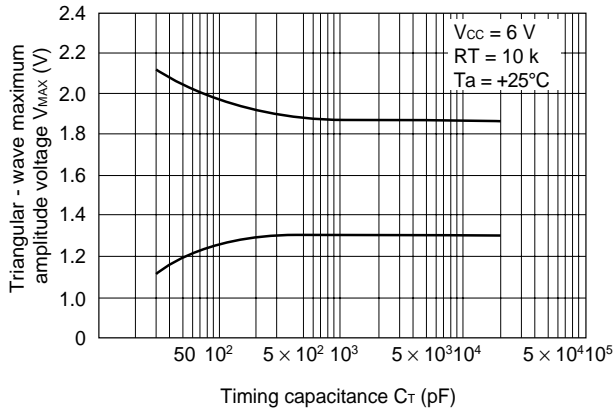

8. Triangular wave frequency vs. Timing resistance

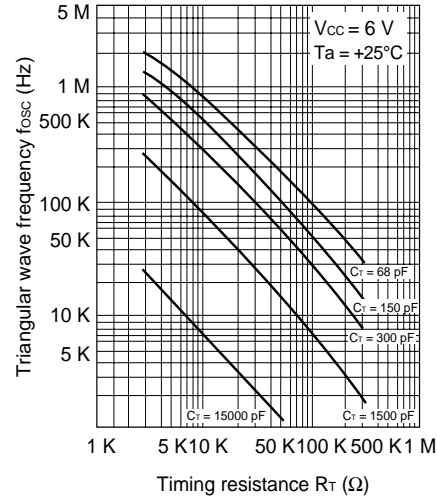

9. Triangular wave cycle vs. Timing capacitance

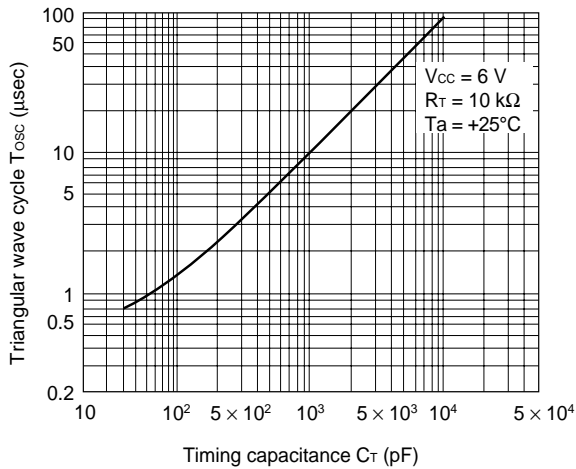

10. Duty vs. Triangular wave frequency

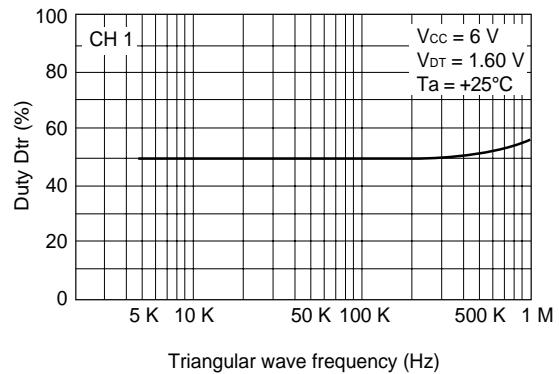

11. Rate of change in triangular wave frequency vs. Ambient temperature (Not using ceramic resonator)

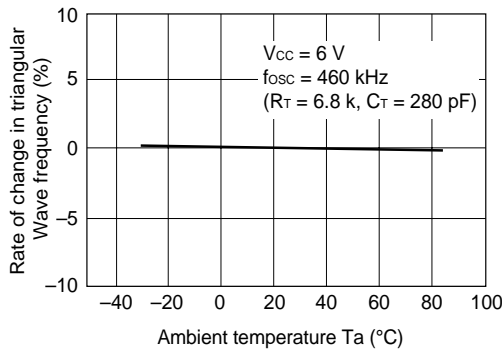

12. Rate of change in triangular wave frequency vs. Ambient temperature (Using ceramic resonator)

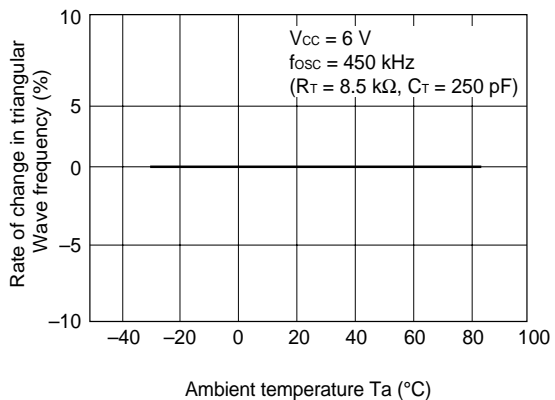

(Continued)

(Continued)

13. Gain vs. Frequency and Phase vs. Frequency

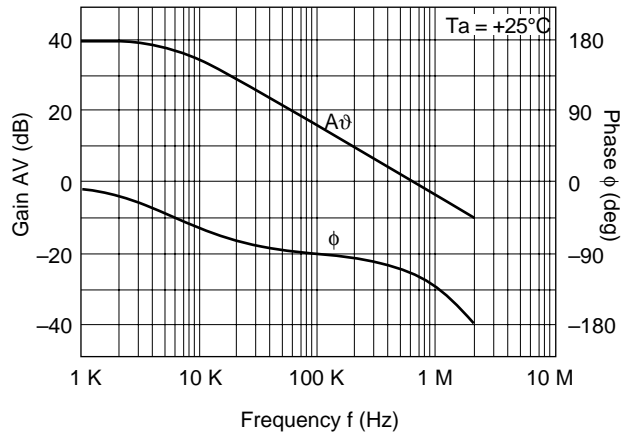

14. Error amp maximum output voltage vs. Frequency

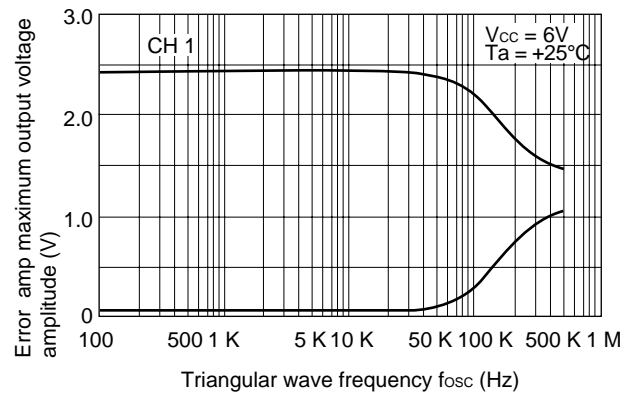

[Measuring Circuit]

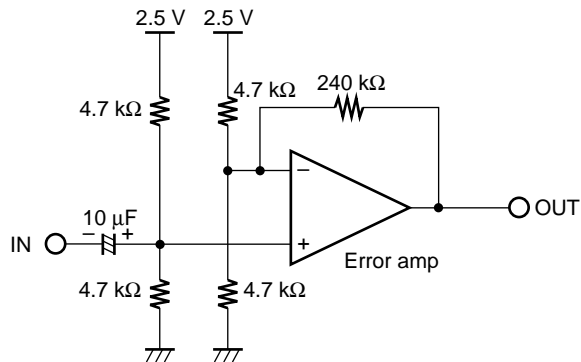

15. Power dissipation vs. Ambient temperature

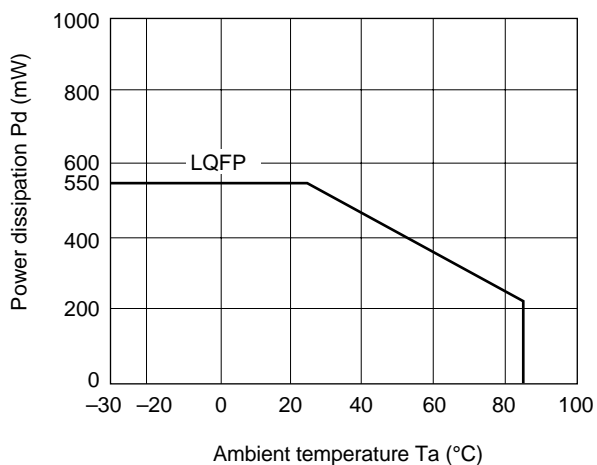

■ METHODS OF SETTING THE OUTPUT VOLTAGE

1. Method of Connecting Channels 1 and 2: When Output Voltage (V_o) is Positive

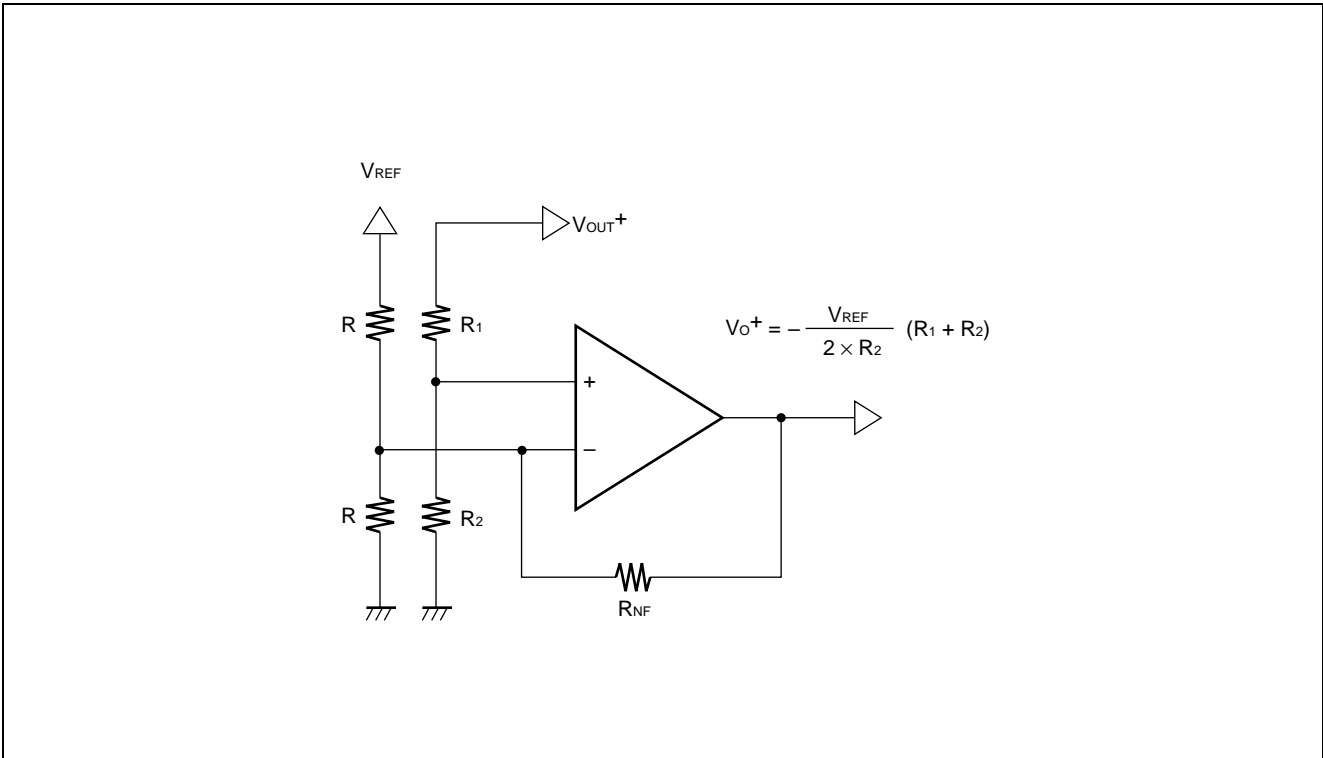

2. Method of Connecting Channels 1 and 2: When Output Voltage (V_o) is Negative

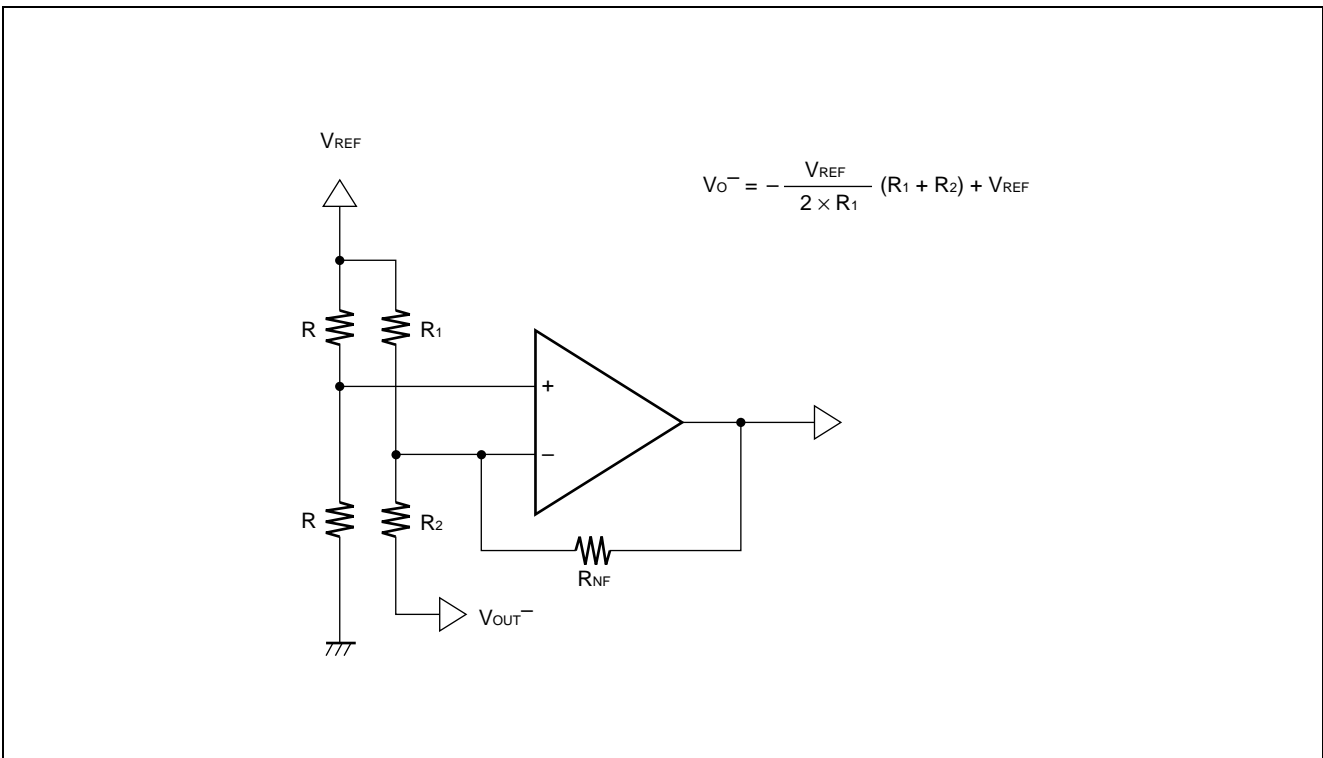

3. Method of Connecting Channels 3 and 4: When Output Voltage (V_o) is Positive

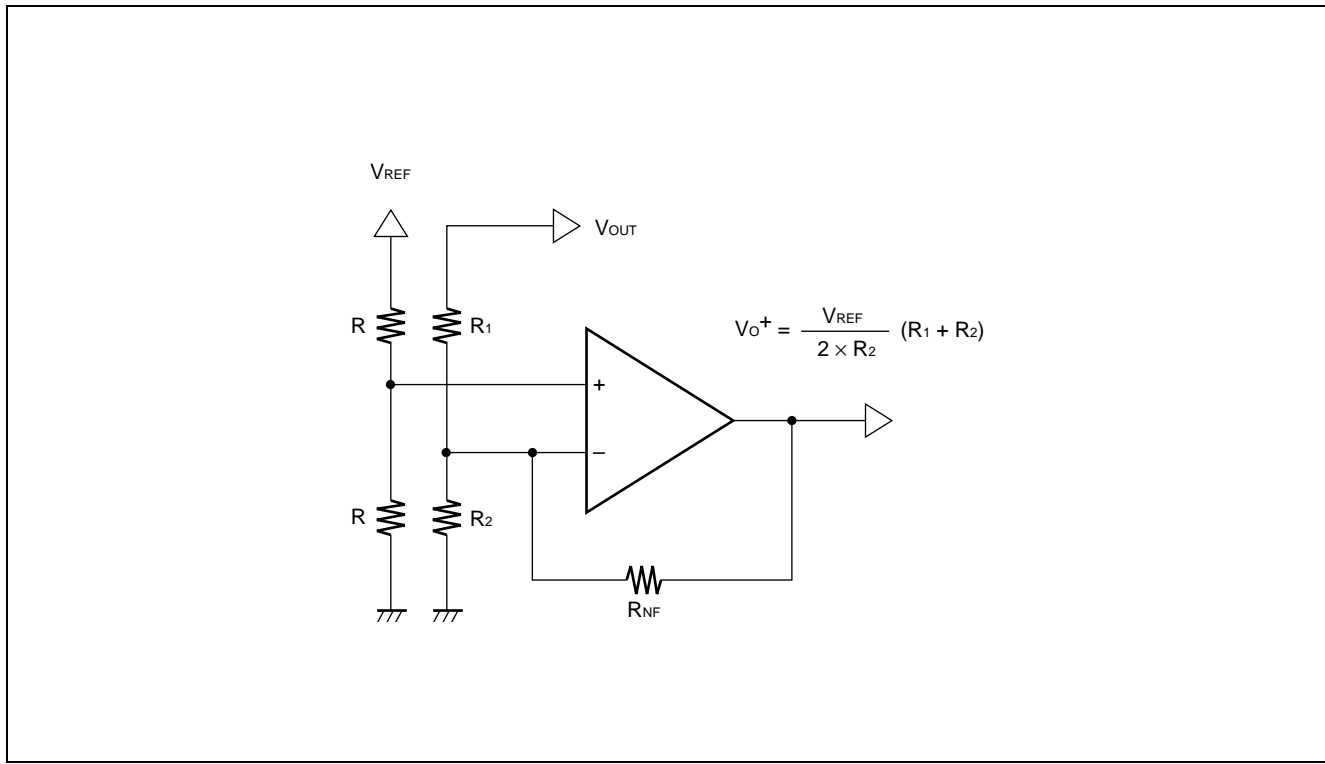

4. Method of Connecting Channels 3 and 4: When Output Voltage (V_o) is Negative

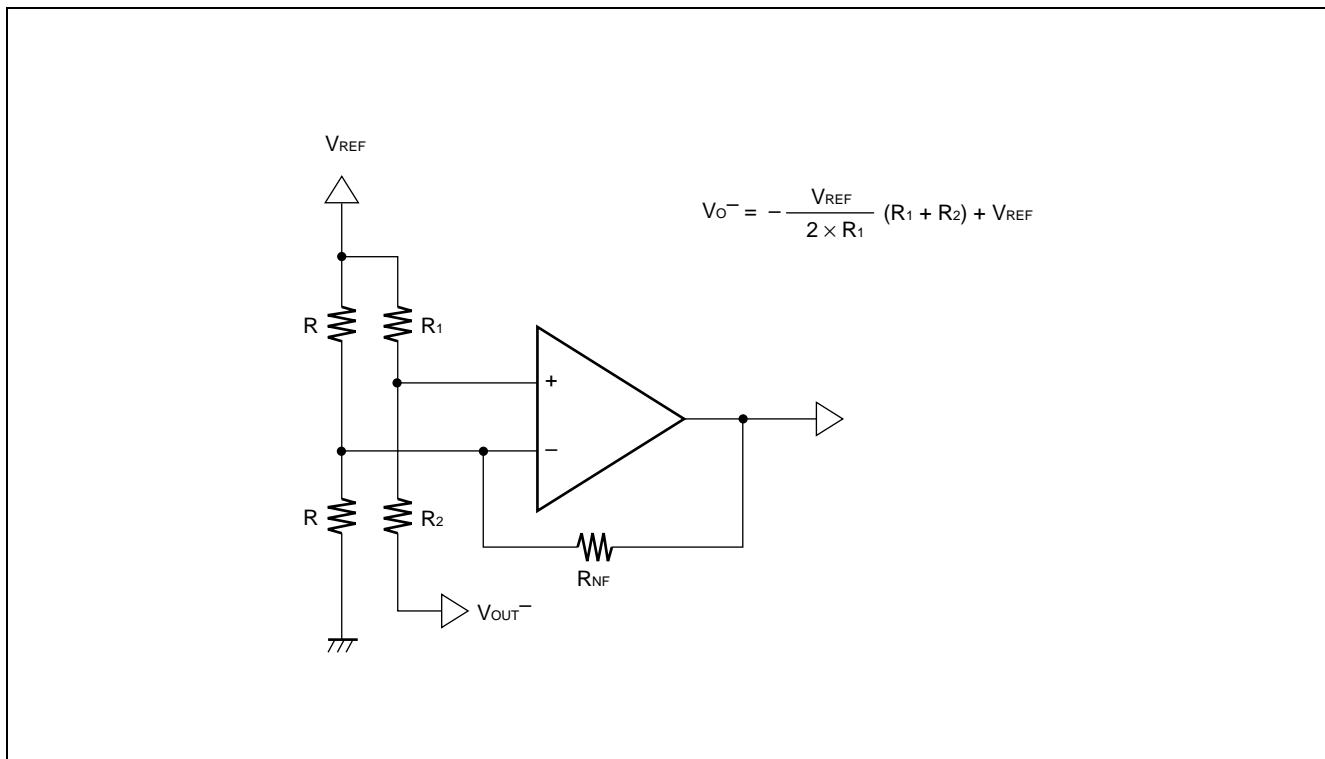

METHOD OF SETTING THE OUTPUT CURRENT

The output circuit is comprised of a totem-pole configuration. Its output current waveform is such that the ON-current value is set by constant current and the OFF-current value is set by a time constant as shown in Figure 2. These output currents are set using the equations below.

- ON-current = $2.5/R_E$ [A]
(Voltage on output current-setting pin $V_E = 2.5$ V)
- OFF-current time constant = proportional to the value of C_B

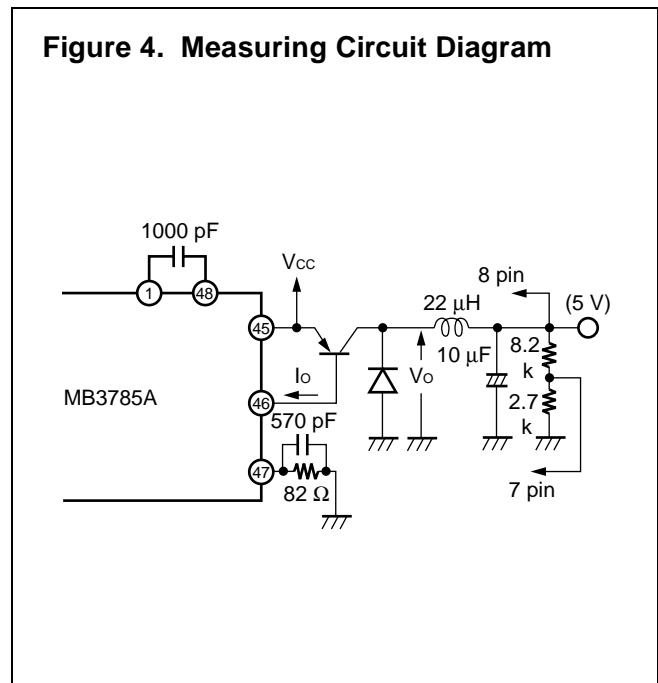
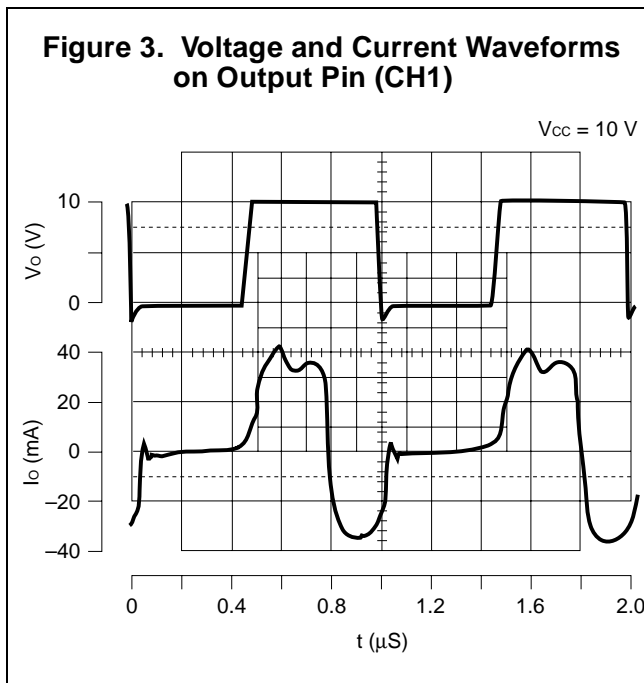
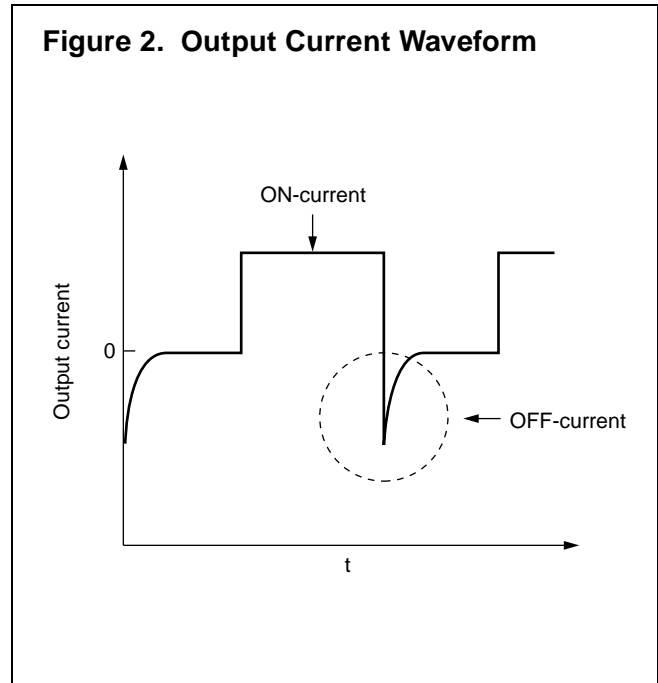
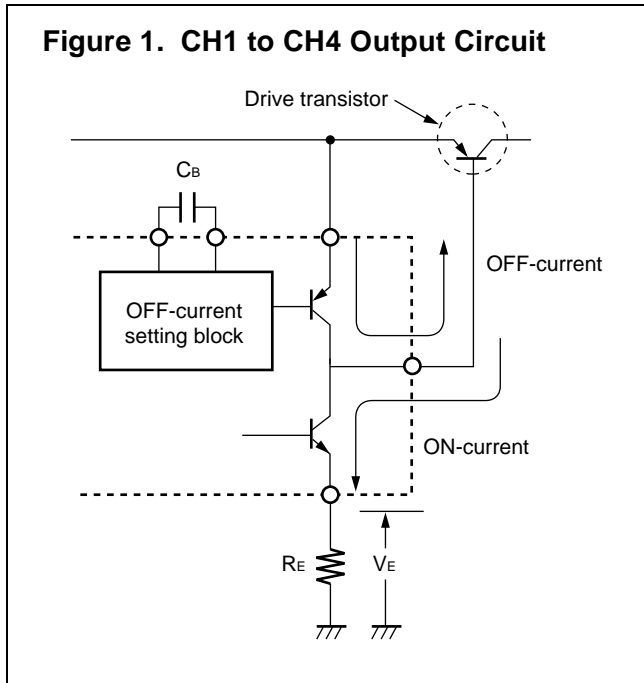

■ METHOD OF SETTING TIME CONSTANT FOR TIMER/LATCH-ACTUATED SHORT-CIRCUITING PROTECTION CIRCUIT

Figure 5 schematically shows the protection latch circuit.

The outputs from the output-shorting detection comparators 1 to 4 are respectively connected to the inverted inputs of the SCP comparator. These inputs are always compared with the reference voltage of approximately 2.1 V which is fed to the non-inverted input of the SCP comparator.

While the switching regulator load conditions are stable, there are no changes in the outputs of the comparators 1 to 4 so that short-circuit protection control keeps equilibrium state. At this time, the voltage on the SCP terminal (pin 23) is held at approximately 50 mV.

When load conditions change rapidly due to a short-circuiting of load, for example, the output voltage of the comparator for the relevant channel goes "H" (2.1 V or more). Consequently, the SCP comparator outputs a "L", causing the transistor Q₁ to turn off, and the short-circuit protection capacitor C_{PE} (externally fitted to the SCP terminal) begins to charge.

$$V_{PE} = 50 \text{ mV} + t_{PE} \times 10^{-6}/C_{PE}$$

$$0.65 = 50 \text{ mV} + t_{PE} \times 10^{-6}/C_{PE}$$

$$C_{PE} = t_{PE}/0.6 \text{ (sec)}$$

When the external capacitor C_{PE} is charged to approximately 0.65 V, the SR latch is set and the output drive transistor is turned off. Simultaneously, the dead time is extended to 100% and the output voltage on the SCP terminal (pin 23) is held "L". As a result, the S-R latch input is closed and C_{PE} is discharged.

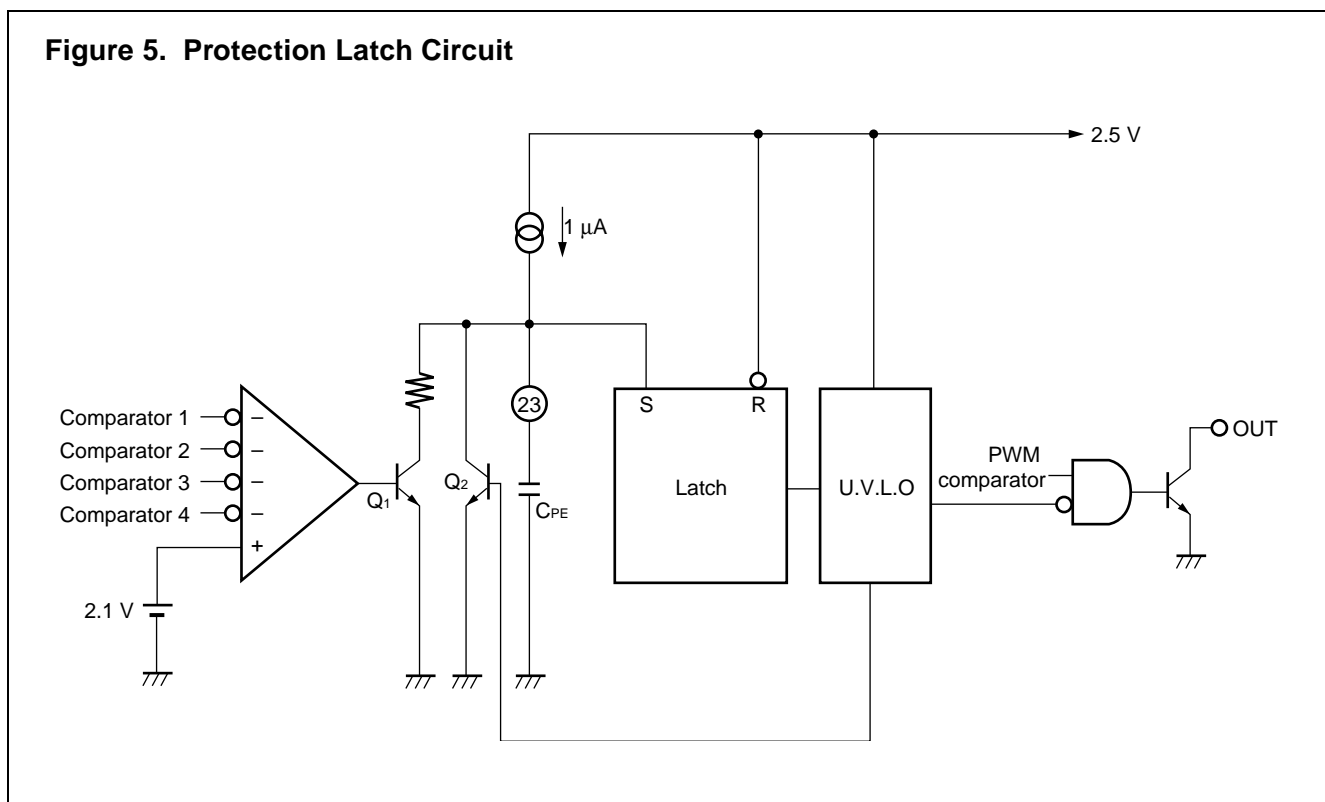

■ TREATMENT WHEN NOT USING SCP

When you do not use the timer/latch-actuated short-circuiting protection circuit, connect the SCP terminal (pin 23) to GND with the shortest distance possible. Also, connect the comparator's input terminal for each channel to the V_{CC1} terminal (pin 18).

Figure 6. Treatment When Not Using SCP

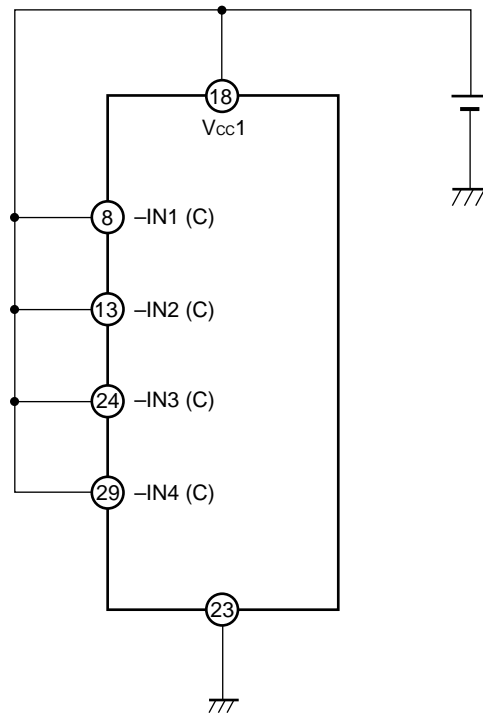

■ METHOD OF SETTING THE TRIANGULAR-WAVE OSCILLATOR CIRCUIT

1. When Not Using Ceramic Resonator

Connect the OSC_{IN} terminal (pin 14) to GND and leave the OSC_{OUT} terminal (pin 15) open. This makes it possible to set the oscillation frequency with only C_T and R_T.

Figure 7. When Not Using Ceramic Resonator

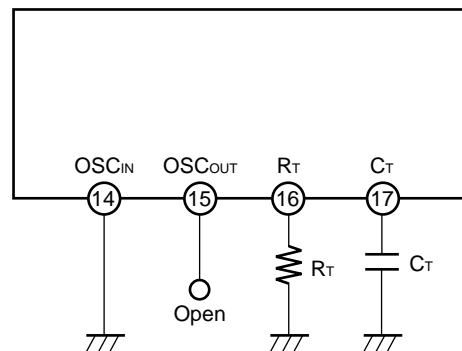

2. When Using Ceramic Resonator

By connecting a ceramic resonator between OSC_{IN} and OSC_{OUT} as shown below, you can set the oscillation frequency. In this case, too, C_T and R_T are required. Determine the values of C_T and R_T so that the oscillation frequency of this RC network is about 5-10% lower than that of the ceramic resonator.

Figure 8. When Using Ceramic Resonator

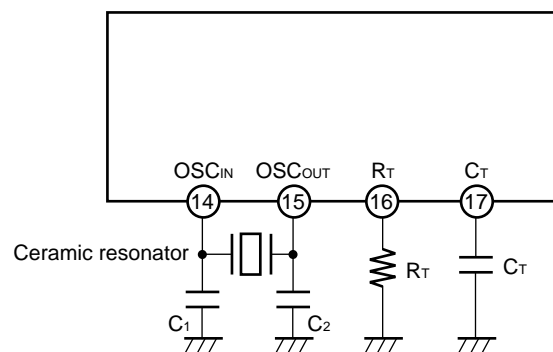

<Precautions>

When the oscillation rise time at power switch-on is compared between a ceramic and a crystal resonator, it is known that the crystal resonator is about 10 to 100 times slower to rise than the ceramic resonator. Therefore, when a crystal resonator is used, system operation as a switching regulator at power switch-on becomes unstable. To avoid this problem, it is recommended that you use a ceramic oscillator because it has a short rise time and, hence, ensures stable operation.

• Crystal Resonator Turn-on Characteristic

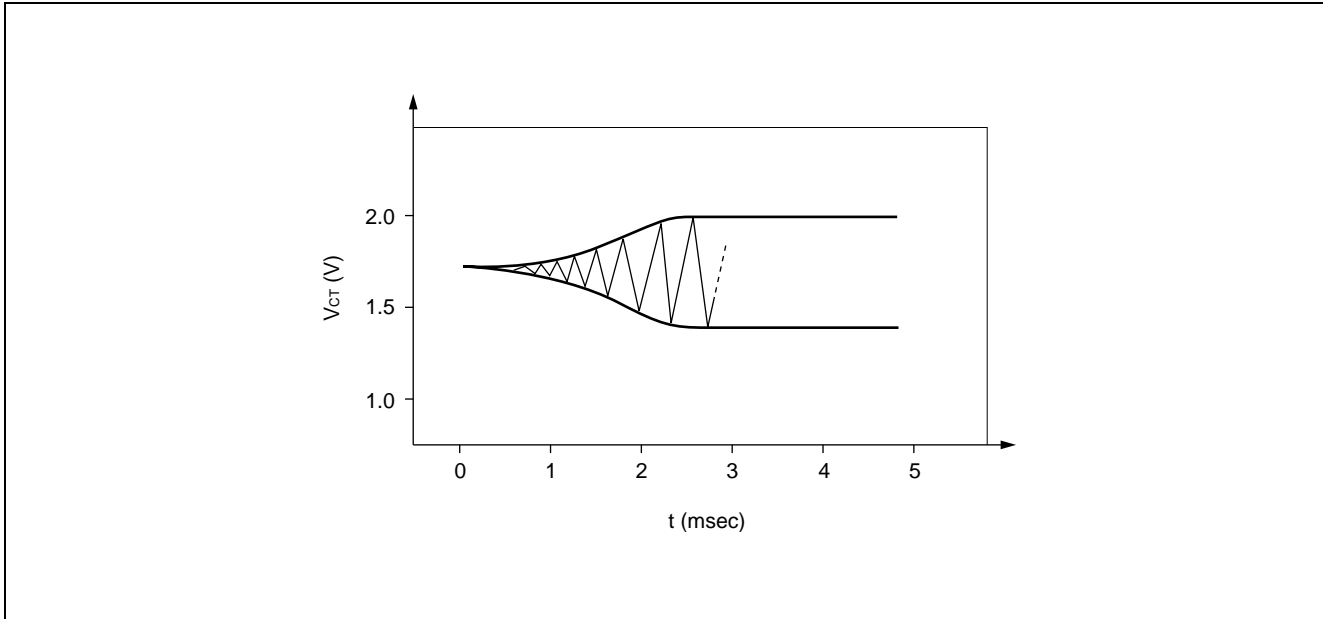

• Ceramic Resonator Turn-on Characteristic

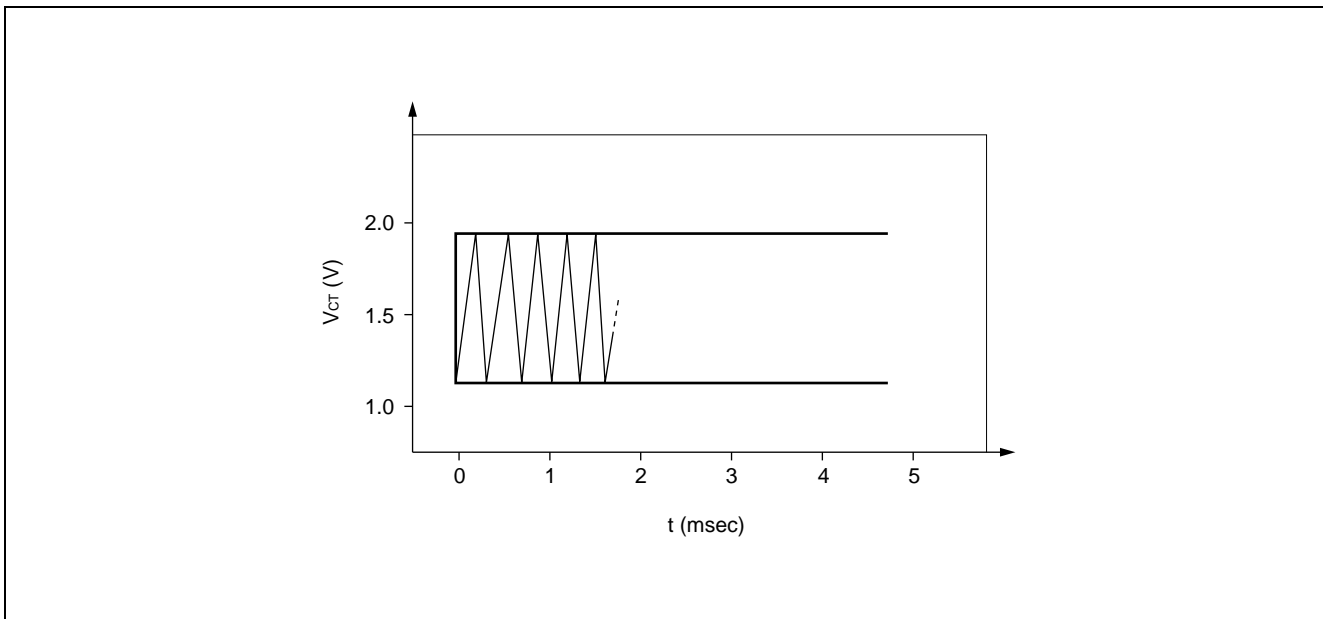

■ METHOD OF SETTING THE DEAD TIME AND SOFT START

1. Dead Time

When the device is set for step-up inverted output based on the flyback method, the output transistor is fixed to a full-on state (ON-duty = 100 %) at power switch-on. To prevent this problem, you may determine the voltages on the DTC terminals (pins 4, 9, 28, and 33) from the V_{REF} voltage so you can easily set the output transistor's dead time (maximum ON-duty) independently for each channel as shown below.

(1) CH1 and CH2 Channels

When the voltage on the DTC terminals (pins 4 and 9) is higher than the triangular-wave output voltage from the oscillator, the output transistor turns off. The dead time calculation formula assuming that triangular-wave amplitude $\cong 0.6$ V and triangular-wave minimum voltage $\cong 1.3$ V is given below.

$$\text{Duty (OFF)} = \frac{V_{dt} - 1.3}{0.6} \times 100 [\%], \quad V_{dt} = \frac{R_2}{R_1 + R_2} \times V_{REF}$$

When you do not use these DTC terminals, connect them to GND.

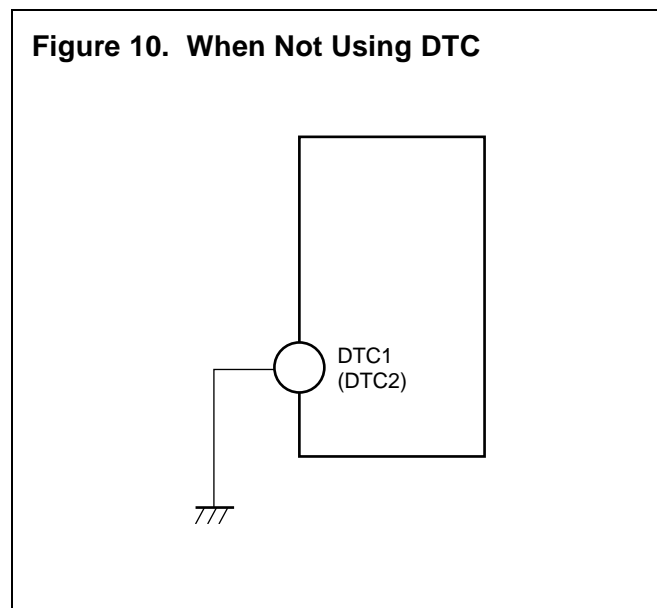
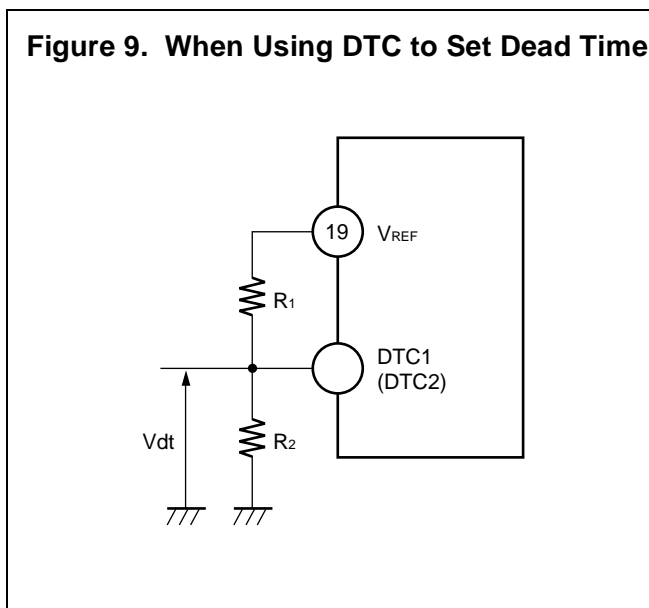

(2) CH3 and CH4 Channels

When the voltage on the DTC terminals (pins 28 and 33) is lower than the triangular-wave output voltage from the oscillator, the output transistor turns off. The dead time calculation formula assuming that triangular-wave amplitude $\cong 0.6$ V and triangular-wave maximum voltage $\cong 1.9$ V is given below.

$$\text{Duty (OFF)} \cong \frac{1.9 - V_{dt}}{0.6} \times 100 [\%], \quad V_{dt} = \frac{R_2}{R_1 + R_2} \times V_{REF}$$

When you do not use these DTC terminals, connect them to V_{REF} .

Figure 11. When Using DTC to Set Dead Time

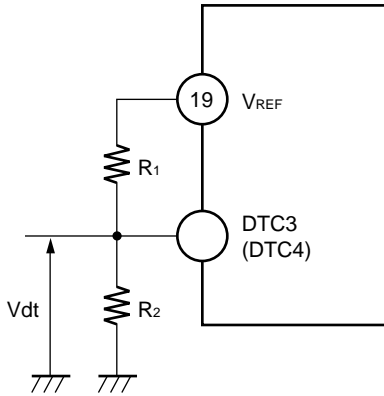
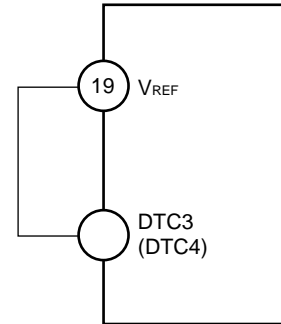

Figure 12. When Not Using DTC



<Precautions>

When you use a ceramic resonator, pay attention when setting the dead time because the triangular-wave amplitude is determined by the values of C_T and R_T .

2. Soft Start

To prevent inrush current at power switch-on, the device can be set for soft start by using the DTC terminals (pins 4, 9, 28, and 33). The diagrams below show how to set.

Figure 13. Setting Soft Start for CH1 and CH2

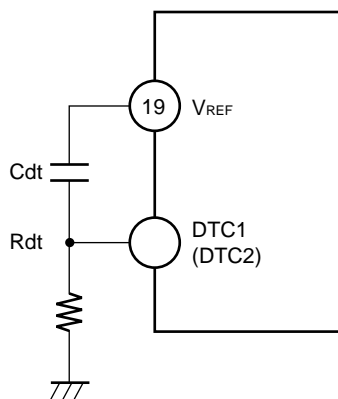
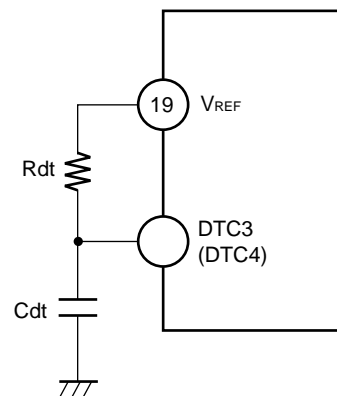

Figure 14. Setting Soft Start for CH3 and CH4



It is also possible to set soft start simultaneously with the dead time by configuring the DTC terminals as shown below.

Figure 15. Setting Dead Time and Soft Start for CH1 and CH2

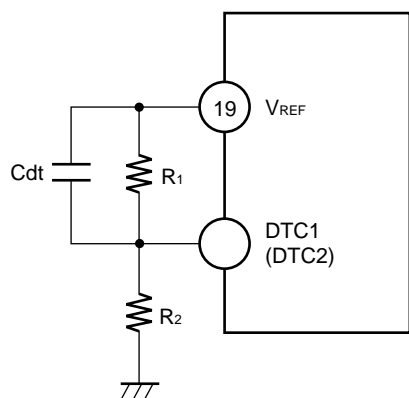
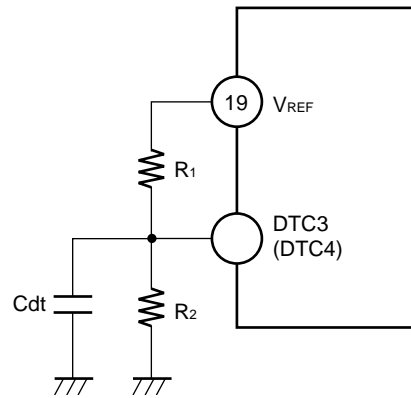

Figure 16. Setting Dead Time and Soft Start for CH3 and CH4



■ EQUIVALENT SERIES RESISTOR AND STABILITY OF SMOOTHING CAPACITOR

The equivalent series resistance (ESR) of a smoothing capacitor in a DC/DC converter greatly affects the phase characteristics of the loop depending on its value.

System stability is improved by ESR because it causes the phase to lead that of the ideal capacitor in high-frequency regions. (See Figures 17 and 19.) Conversely, if a low-ESR smoothing capacitor is used, system stability deteriorates. Therefore, use of a low-ESR semiconductor electrolytic capacitors (OS – CON) or tantalum capacitors calls for careful attention.

Figure 17. Basic Circuit of Stepdown DC/DC Converter

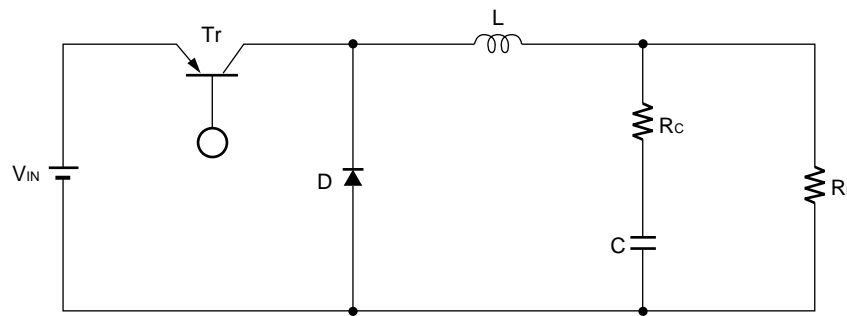

Figure 18. Gain-Frequency Characteristic

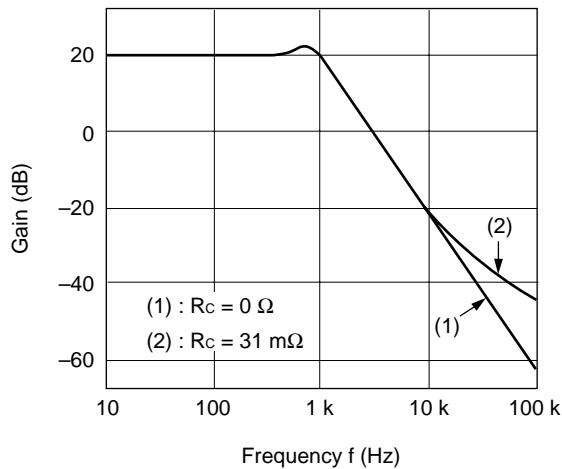
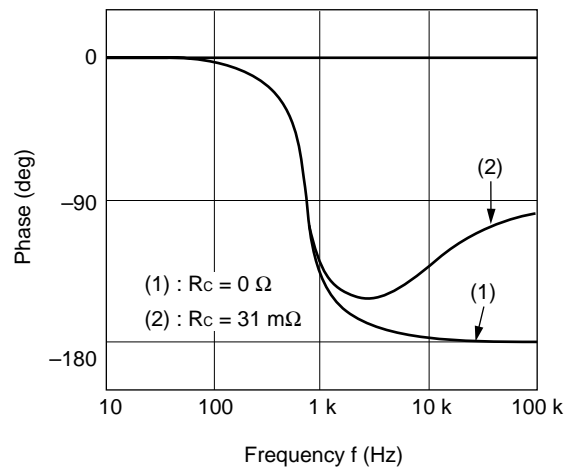

Figure 19. Phase-Frequency Characteristic



(Reference Data)

The phase margin is halved by changing the smoothing capacitor from an aluminum electrolytic capacitor ($R_c = 1.0 \Omega$) to a small-ESR semiconductor electrolytic capacitor (OS – CON; $R_c = 0.2 \Omega$). (See Figure 21 and 22.)

Figure 20. DC/DC Converter AV-φ Characteristic Measuring Circuit

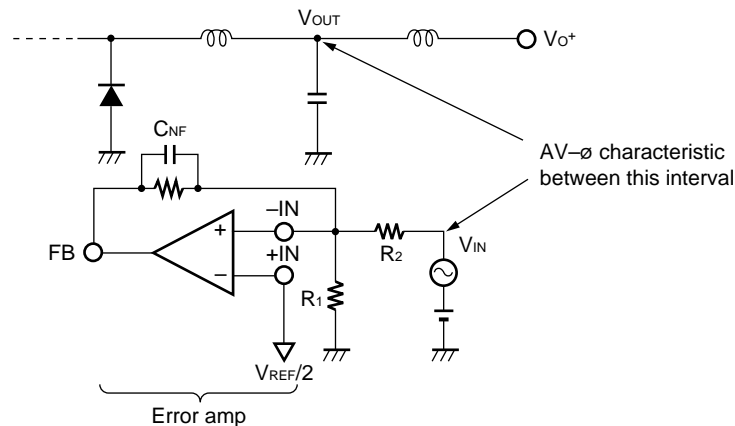

Figure 21. Gain-Frequency Characteristic

Gain - frequency and phase frequency characteristics of Al electrolytic capacitor (DC/DC converter +5 V output)

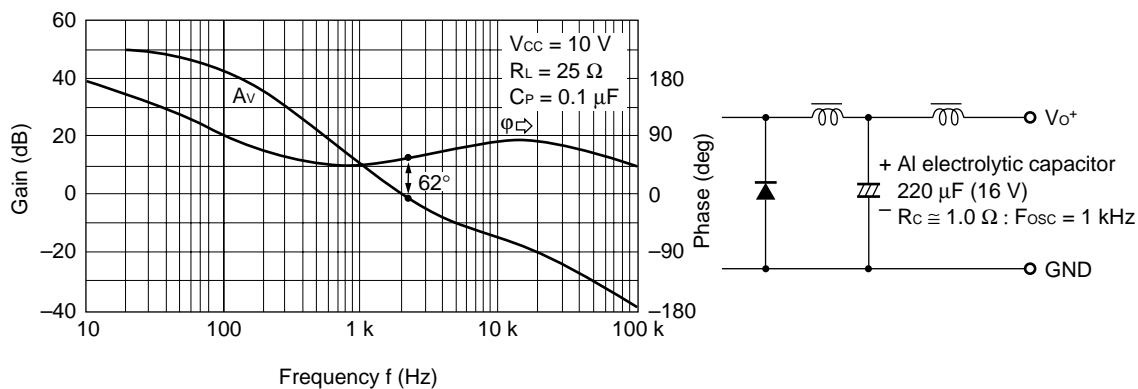
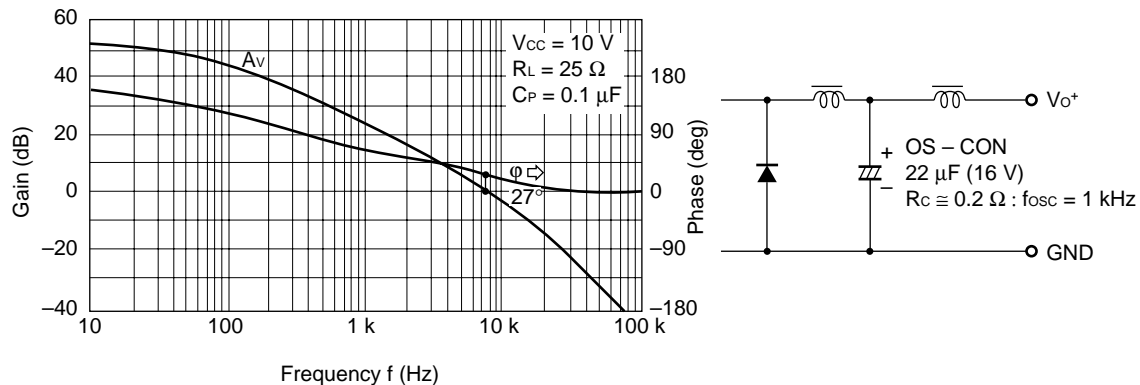

Figure 22. Phase-Frequency Characteristic

Gain - frequency and phase frequency characteristics of OS – CON (DC/DC converter +5 V output)



MB3785A

EXAMPLE OF APPLICATION CIRCUIT

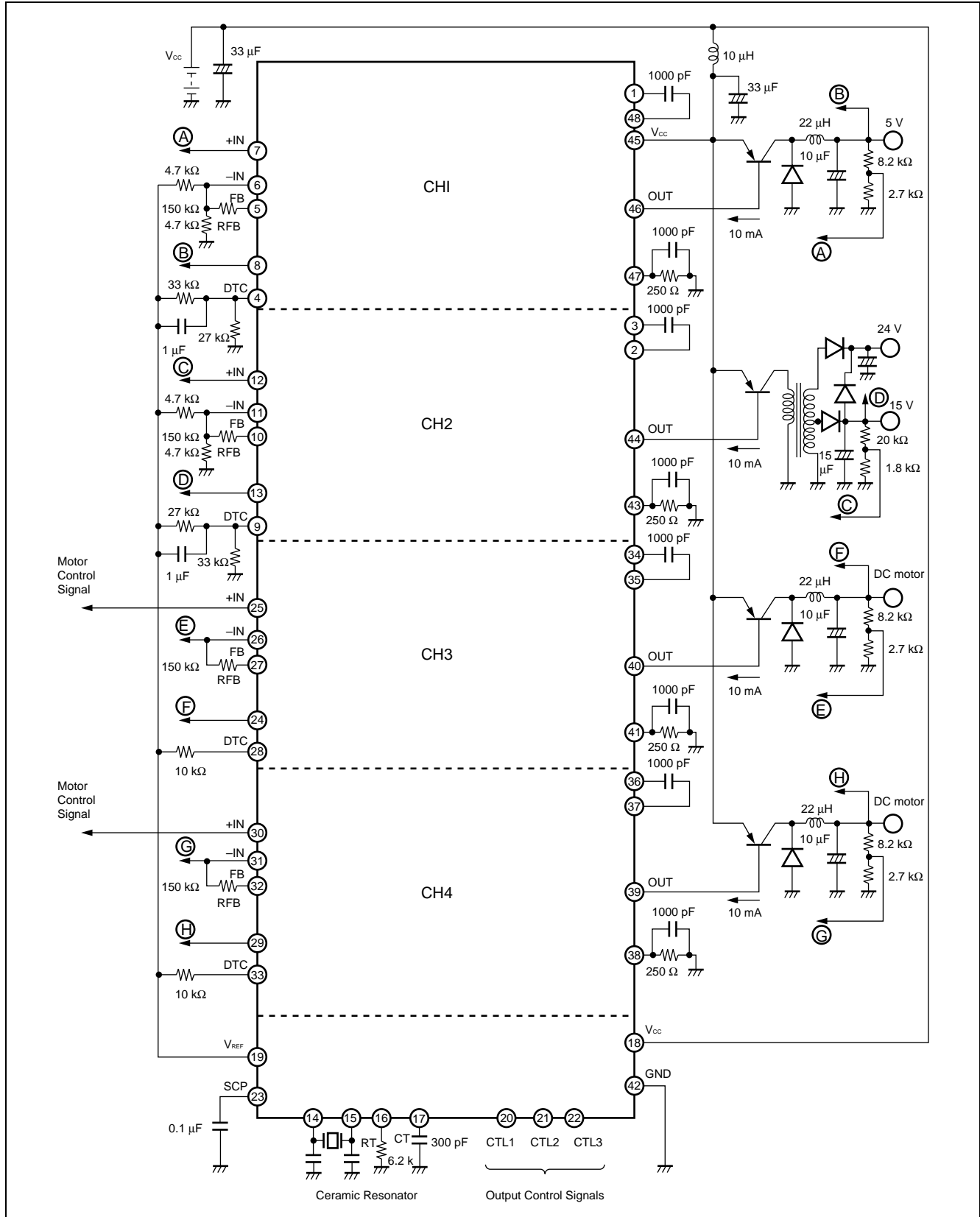

■ PRECAUTIONS ON USING THE DEVICE

1. Do not input voltages greater than the maximum rating.

Inputting voltages greater than the maximum rating may damage the device.

2. Always use the device under recommended operating conditions.

If a voltage greater than the maximum value is input to the device, its electrical characteristics may not be guaranteed. Similarly, inputting a voltage below the minimum value may cause device operation to become unstable.

3. For grounding the printed circuit board, use as wide ground lines as possible to prevent high-frequency noise.

Because the device uses high frequencies, it tends to generate high-frequency noise.

4. Take the following measures for protection against static charge:

- For containing semiconductor devices, use an antistatic or conductive container.
- When storing or transporting device-mounted circuit boards, use a conductive bag or container.
- Ground the workbenches, tools, and measuring equipment to earth.
- Make sure that operators wear wrist straps or other appropriate fittings grounded to earth via a resistance of 250 k to 1 M ohms placed in series between the human body and earth.

■ ORDERING INFORMATION

| Part number | Package | Remarks |
|-------------|--------------------------------------|---------|
| MB3785APFV | 48-pin plastic LQFP (FPT-48P-M05) | |

MB3785A

■ PACKAGE DIMENSION

48-pin Plastic LQFP
(FPT-48P-M05)

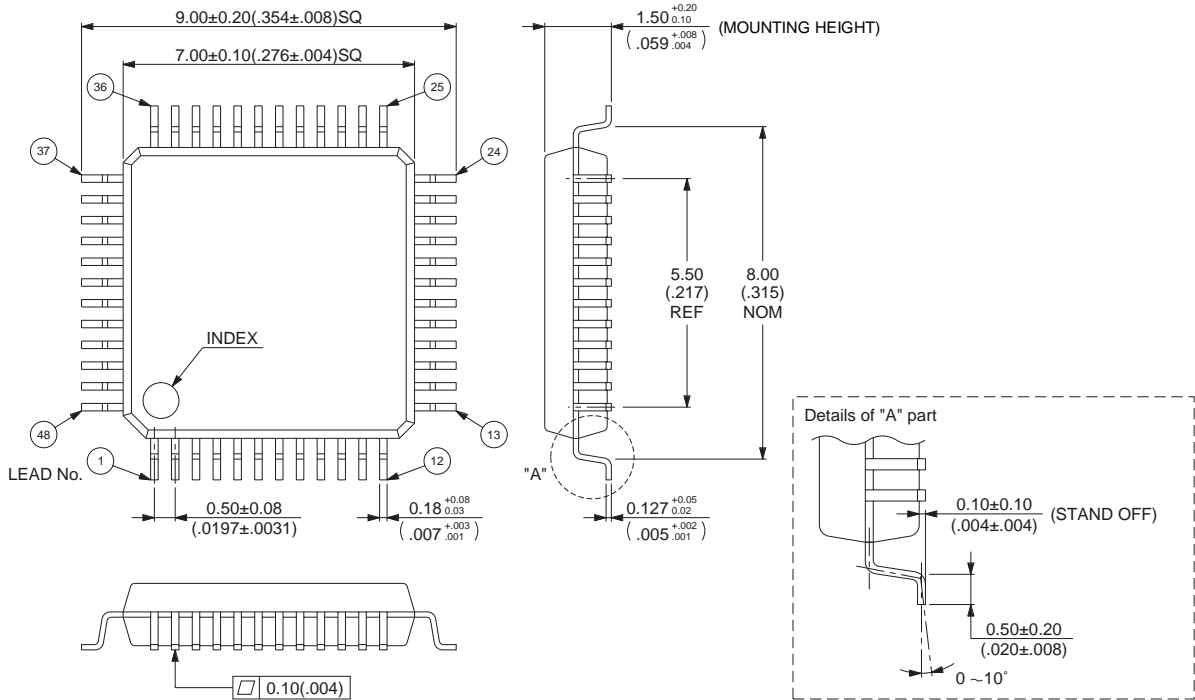

© 1995 FUJITSU LIMITED F48013S-2C-5

Dimensions in: mm (inches)

FUJITSU LIMITED

For further information please contact:

Japan

FUJITSU LIMITED
Corporate Global Business Support Division
Electronic Devices
KAWASAKI PLANT, 4-1-1, Kamikodanaka
Nakahara-ku, Kawasaki-shi
Kanagawa 211-8588, Japan
Tel: (044) 754-3763
Fax: (044) 754-3329

<http://www.fujitsu.co.jp/>

North and South America

FUJITSU MICROELECTRONICS, INC.
Semiconductor Division
3545 North First Street
San Jose, CA 95134-1804, USA
Tel: (408) 922-9000
Fax: (408) 922-9179

Customer Response Center
Mon. - Fri.: 7 am - 5 pm (PST)
Tel: (800) 866-8608
Fax: (408) 922-9179

<http://www.fujitsumicro.com/>

Europe

FUJITSU MIKROELEKTRONIK GmbH
Am Siebenstein 6-10
D-63303 Dreieich-Buchsschlag
Germany
Tel: (06103) 690-0
Fax: (06103) 690-122

<http://www.fujitsu-edc.com/>

Asia Pacific

FUJITSU MICROELECTRONICS ASIA PTE LTD
#05-08, 151 Lorong Chuan
New Tech Park
Singapore 556741
Tel: (65) 281-0770
Fax: (65) 281-0220

<http://www.fmap.com.sg/>

F9803

© FUJITSU LIMITED Printed in Japan

All Rights Reserved.

The contents of this document are subject to change without notice. Customers are advised to consult with FUJITSU sales representatives before ordering.

The information and circuit diagrams in this document presented as examples of semiconductor device applications, and are not intended to be incorporated in devices for actual use. Also, FUJITSU is unable to assume responsibility for infringement of any patent rights or other rights of third parties arising from the use of this information or circuit diagrams.

FUJITSU semiconductor devices are intended for use in standard applications (computers, office automation and other office equipment, industrial, communications, and measurement equipment, personal or household devices, etc.).

CAUTION:

Customers considering the use of our products in special applications where failure or abnormal operation may directly affect human lives or cause physical injury or property damage, or where extremely high levels of reliability are demanded (such as aerospace systems, atomic energy controls, sea floor repeaters, vehicle operating controls, medical devices for life support, etc.) are requested to consult with FUJITSU sales representatives before such use. The company will not be responsible for damages arising from such use without prior approval.

Any semiconductor devices have inherently a certain rate of failure. You must protect against injury, damage or loss from such failures by incorporating safety design measures into your facility and equipment such as redundancy, fire protection, and prevention of over-current levels and other abnormal operating conditions.

If any products described in this document represent goods or technologies subject to certain restrictions on export under the Foreign Exchange and Foreign Trade Control Law of Japan, the prior authorization by Japanese government should be required for export of those products from Japan.