



SP207H/SP211H

+5V High-Speed RS-232 Transceivers

- Single 5V Supply Operation
- 0.1µF External Charge Pump Capacitors
- 460kbps Minimum Data Rate
- Standard SOIC and SSOP Packages
- SP207H - Five (5) Drivers and Three (3) Receivers
 SP211H - Four (4) Drivers and Five (5) Receivers
- 1µA Shutdown Mode
- WakeUp Feature in Shutdown Mode
- Tri-State Receiver Outputs
- Ideal for V.34 and High Speed RS-232 Applications



DESCRIPTION...

The **SP207H** and **SP211H** are multi-channel RS-232 line transceivers configured to fit most communication needs. The "H" series is based on **Sipex's SP200 Series** transceivers and has been enhanced for speed. The data rate is improved to over 460kbps which easily meets the 230.4kbps data rates for V.34. The **SP207H** and **SP211H** use the same on-board charge pump to provide ±10V voltage levels, using 0.1µF charge pump capacitors to save board space and reduce circuit cost. The **SP207HB**, **SP211H** and **SP211HB** feature a low-power shutdown mode, which reduces power supply drain to 1µA. A WakeUp function keeps the receivers active in the shutdown mode (**SP207HB** and **SP211HB** only).



Model	Number of RS-232		No. of Receivers Active in Shutdown	No. of External 0.1µF Capacitors	Shutdown	WakeUp	TTL Tri-State
	Drivers	Receivers					
SP207H	5	3	0	4	No	No	No
SP207HB	5	3	3	4	Yes	Yes	Yes
SP211H	4	5	0	4	Yes	No	Yes
SP211HB	4	5	5	4	Yes	Yes	Yes

Table 1. Model Selection Table

ABSOLUTE MAXIMUM RATINGS

These are stress ratings only and functional operation of the device at these or any other above those indicated in the operation sections of the specifications below is not implied. Exposure to absolute maximum rating conditions for extended periods of time may affect reliability.

V_{CC}	+6V
V^+	$(V_{CC} - 0.3V)$ to +13.2V
V^-	13.2V
Input Voltages	
Tx_{IN}	-0.3V to $(V_{CC} + 0.3V)$
Rx_{IN}	$\pm 30V$ at $\leq 100mA$
Output Voltages	
T_{OUT}	$(V^+ + 0.3V)$ to $(V^- - 0.3V)$
R_{OUT}	-0.3V to $(V_{CC} + 0.3V)$
Short Circuit Duration on T_{OUT}	Continuous
Power Dissipation	
Plastic DIP	375mW
(derate 7mW/°C above +70°C)	
Small Outline	375mW
(derate 7mW/°C above +70°C)	

SPECIFICATIONS

V_{CC} at nominal ratings; 0.1 μ F charge pump capacitors; T_{MIN} to T_{MAX} unless otherwise noted.

PARAMETER	MIN.	TYP.	MAX.	UNIT	CONDITIONS
TTL INPUTS (DRIVER)					
Logic Threshold					T_{IN} , EN, SD
V_{IL}			0.8	Volts	
V_{IH}	2.0			Volts	
Logic Pullup Current		1.5	10.0	μ A	$T_{IN} = 0V$
Data Rate	460	600		kbps	$C_L = 1,000pF, R_L = 3k\Omega$
TTL OUTPUTS (RECEIVER)					
Compatibility		TTL/CMOS			R_{OUT}
V_{OL}			0.4	Volts	$I_{OUT} = 3.2mA; V_{CC} = +5V$
V_{OH}	3.5			Volts	$I_{OUT} = -1.0mA$
Leakage Current		0.05	± 10	μ A	$EN = V_{CC}; 0V \leq R_{OUT} \leq V_{CC}; T_A = +25^\circ C$
RS-232 OUTPUT (DRIVER)					
Output Voltage Swing	± 5	± 7		Volts	All transmitter outputs loaded with 3k Ω to ground
Power-Off Output Resistance	300			Ohms	$V_{CC} = 0V; V_{OUT} = \pm 2V$
Output Short Circuit Current		± 25		mA	Infinite duration
RS-232 INPUT (RECEIVER)					
Voltage Range	-15		+15	Volts	$T_A = +25^\circ C$
Logic Pull Down Current		3.0	10.0	μ A	
Voltage Threshold					
V_{IL}	0.8	1.2		Volts	$V_{CC} = +5V, T_A = +25^\circ C$
V_{IH}		1.7	2.4	Volts	$V_{CC} = +5V, T_A = +25^\circ C$
Hysteresis	0.2	0.5	1.0	Volts	$V_{CC} = +5V$
Resistance	3	5	7	k Ω	$V_{IN} = \pm 15V; T_A = +25^\circ C$
Data Rate	460	600		kbps	
DYNAMIC CHARACTERISTICS					
Propagation Delay		1.0		μ s	TTL-to-RS-232
		1.5		μ s	RS-232-to-TTL
Instantaneous Slew Rate		60		V/ μ s	$C_L = 50pF, R_L = 3-7k\Omega; T_A = +25^\circ C$
Transition Region Slew Rate		5		V/ μ s	$C_L = 1,000pF, R_L = 3k\Omega; measured from +3V to -3V or -3V to +3V$

SPECIFICATIONS

V_{CC} at nominal ratings; 0.1 μ F charge pump capacitors; T_{MIN} to T_{MAX} , unless otherwise noted.

PARAMETER	MIN.	TYP.	MAX.	UNIT	CONDITIONS
Output Enable Time		400		ns	
Output Disable Time		250		ns	
POWER REQUIREMENTS					
V_{CC}	4.75	5.00	5.25	Volts	No load; $V_{CC} = 5V$; $T_A = +25^\circ C$ All transmitters $R_L = 3k\Omega$; $T_A = +25^\circ C$ $T_A = +25^\circ C$
I_{CC}		5	10	mA	
Shutdown Current		20	10	mA	
		1		μA	
ENVIRONMENTAL AND MECHANICAL					
Operating Temperature					
Commercial, -C	0		+70	$^\circ C$	
Extended, -E	-40		+85	$^\circ C$	
Storage Temperature	-65		+125	$^\circ C$	
Package					
-A	Shrink (SSOP) small outline				
-T	Wide (SOIC) small outline				

PINOUT

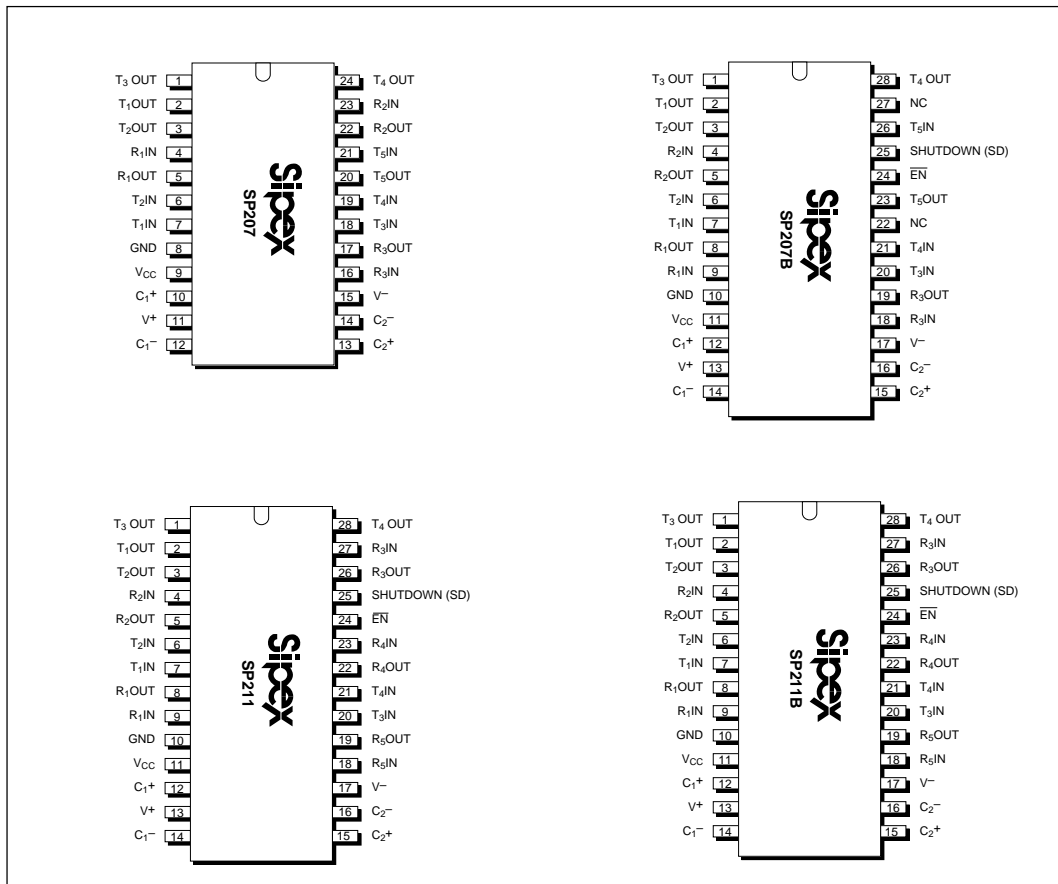

FEATURES...

The **SP207H** and **SP211H** line transceivers provide a variety of configurations to fit most communication needs, especially those applications where $\pm 12V$ is not available. Both products feature low-power CMOS construction and **Sipex**-proprietary on-board charge pump circuitry to generate the $\pm 10V$ RS-232 voltage levels. The ability to use $0.1\mu F$ charge pump capacitors saves board space and reduces circuit cost.

The **SP207HB** and **SP211H** models feature a low-power shutdown mode, which reduces power supply drain to $1\mu A$. The **SP207HB** and **SP211HB** are equipped with the WakeUp function. The WakeUp function keeps the receivers active in the shutdown mode, unless disabled by the \overline{EN} pin.

THEORY OF OPERATION

The **SP207H** and **SP211H** are made up of three basic circuit blocks — 1) transmitter/driver, 2) receiver and 3) the **Sipex**-proprietary charge pump.

Charge-Pump

The charge pump is a **Sipex**-patented design (5,306,954) and uses a unique approach compared to older less-efficient designs. The charge pump still requires four external capacitors, but uses a four-phase voltage shifting technique to attain symmetrical $10V$ power supplies. *Figure 3a* shows the waveform found on the positive side of capacitor C_2 , and *Figure 3b* shows the

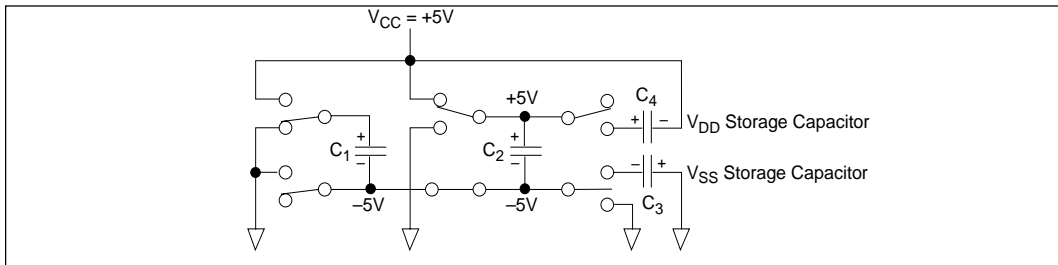

Figure 1. Charge Pump — Phase 1

negative side of capacitor C_2 . There is a free-running oscillator that controls the four phases of the voltage shifting. A description of each phase follows.

Phase 1

— V_{SS} charge storage — During this phase of the clock cycle, the positive side of capacitors C_1 and C_2 are initially charged to +5V. C_1^+ is then switched to ground and the charge in C_1^- is transferred to C_2^- . Since C_2^+ is connected to +5V, the voltage potential across capacitor C_2 is now 10V.

Phase 2

— V_{SS} transfer — Phase two of the clock connects the negative terminal of C_2 to the V_{SS} storage capacitor and the positive terminal of C_2 to ground, and transfers the generated -10V to C_3 . Simultaneously, the positive side of capacitor C_1 is switched to +5V and the negative side is connected to ground.

Phase 3

— V_{DD} charge storage — The third phase of the clock is identical to the first phase — the charge transferred in C_1 produces -5V in the negative terminal of C_1 , which is applied to the negative side of capacitor C_2 . Since C_2^+ is at +5V, the

voltage potential across C_2 is 10V.

Phase 4

— V_{DD} transfer — The fourth phase of the clock connects the negative terminal of C_2 to ground, and transfers the generated 10V across C_2 to C_4 , the V_{DD} storage capacitor. Again, simultaneously with this, the positive side of capacitor C_1 is switched to +5V and the negative side is connected to ground, and the cycle begins again.

Since both V^+ and V^- are separately generated from V_{CC} ; in a no-load condition V^+ and V^- will be symmetrical. Older charge pump approaches that generate V^- from V^+ will show a decrease in the magnitude of V^- compared to V^+ due to the inherent inefficiencies in the design.

The clock rate for the charge pump typically operates at 15kHz. The external capacitors can be as low as 0.1 μ F with a 16V breakdown voltage rating.

Transmitter/Driver

The drivers are inverting transmitters which have been improved for speed over the **SP200 Series**. The transmitters accept either TTL or CMOS inputs and output the RS-232 signals at data rates over 400kbps. Typically, the RS-232 output volt

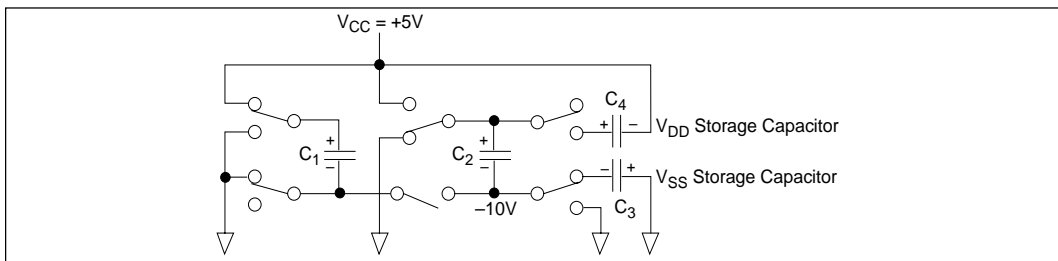

Figure 2. Charge Pump — Phase 2

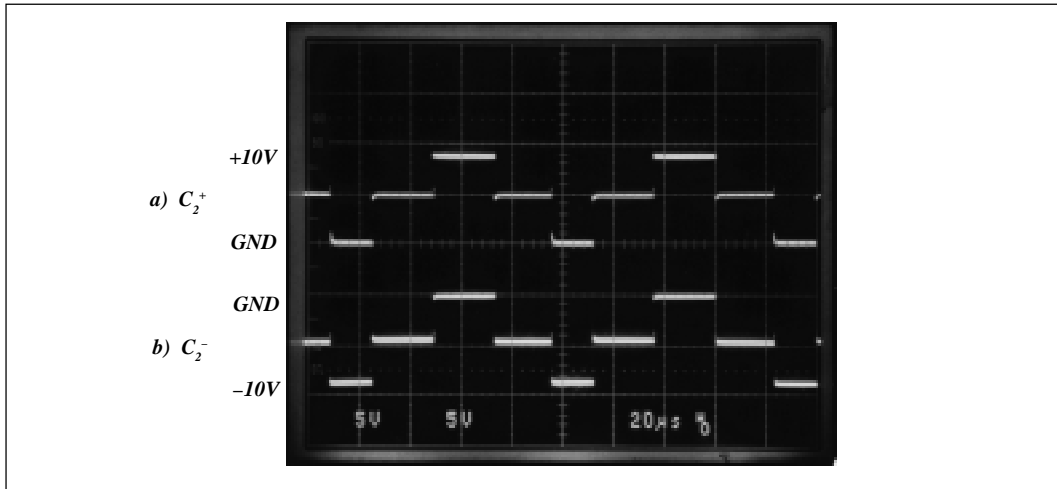

Figure 3. Charge Pump Waveforms

age swing is $\pm 9V$ with no load, and $\pm 5V$ minimum with full load. The transmitter outputs are protected against infinite short-circuits to ground without degradation in reliability. The **SP207HB**, **SP211H** and **SP211HB** drivers can be tri-stated by using the SHUTDOWN function.

In the “power off” state, the output impedance will remain greater than 300 ohms, again satisfying the RS-232 specifications. Should the input of the driver be left open, an internal 400Kohm pullup resistor to V_{CC} forces the input high, thus committing the output to a low state.

Because of the increased speed, the slew rate is typically $60V/\mu S$ which is above the RS-232 specification of $30V/\mu S$. This is the only parameter that exceeds the RS-232 limits.

Receivers

The receivers convert RS-232 input signals to inverted TTL signals. Since the input is usually from a transmission line where long cable lengths and system interference can degrade the signal, the inputs have a typical hysteresis margin of 500mV. This ensures that the receiver is virtually immune to noisy transmission lines. Should an input be left unconnected, a 5Kohm pulldown resistor to ground will commit the output of the receiver to a high state.

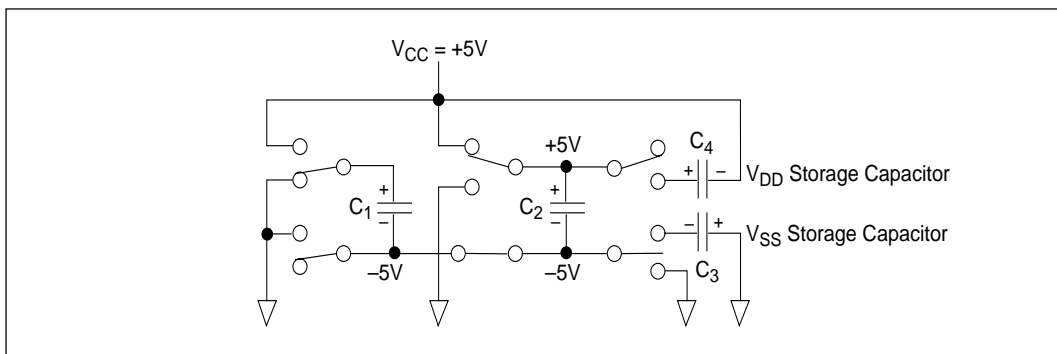

Figure 4. Charge Pump — Phase 3

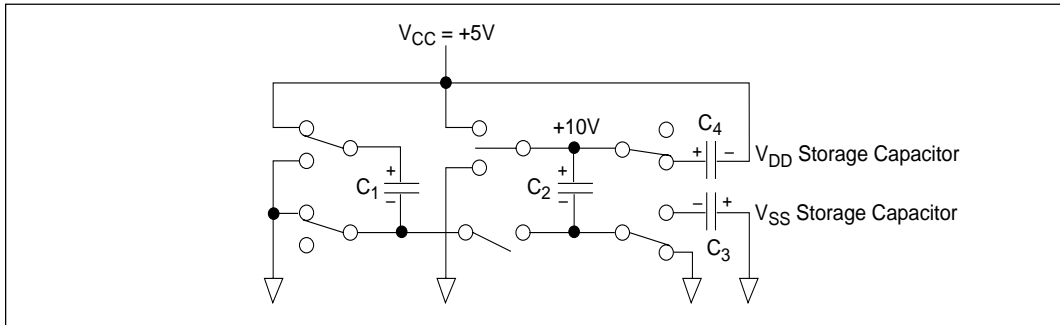

Figure 5. Charge Pump — Phase 4

SHUTDOWN MODE

The **SP207HB**, **SP211H** and **SP211HB** all feature a control input which will disable the device and reduce the power supply current to less than 10 μ A, making the parts ideal for battery-powered systems. In the “shutdown” mode the receivers and transmitters will both be tri-stated. The V⁺ output of the charge pump will discharge to V_{CC}, and the V⁻ output will discharge to ground.

For complete shutdown to occur and the 10 μ A power drain to be realized, the following conditions must be met:

- +5V must be applied to the SD pin
- ENABLE must be either 0V, +5.0V or not connected
- the transmitter inputs must be either +5.0V or not connected
- V_{CC} must be +5V
- Receiver inputs must be >0V and <+5V

ENABLE

The **SP207HB**, **SP211H** and **SP211HB** feature an enable input pin, which allows the receiver

outputs to be either tri-stated or enabled. This can be especially useful when the receiver is tied directly to a microprocessor data bus. The enable is active low; that is, 0V applied to the ENABLE pin will enable the receiver outputs.

WAKEUP FUNCTION

The **SP207HB** and **SP211HB** have a wake-up feature that keeps all the receivers in an enabled state when the device is in the shutdown mode. With only the receivers active during shutdown, the devices draw 5–10 μ A of supply current. A typical application of this function would be where a modem is interfaced to a computer in a power-down mode. The ring indicator signal from the modem could be passed through an active receiver that is in the shutdown mode. The ring indicator signal would propagate through the receiver to the power management circuitry of the computer to power up the microprocessor and the **SP207HB/SP211HB** drivers. After the supply voltage to the transceivers reaches +5.0V, the SHUTDOWN pin can be disabled. All receivers that are active during shutdown maintain 500mV (typ.) of hysteresis.

SD	$\overline{\text{EN}}$	Power Up/Down	Receiver Outputs
0	0	Up	Enable
0	1	Up	Tri-state
1	0	Down	Tri-state
1	1	Down	Tri-state

Table 2. Truth Table for SP2xxH

SD	$\overline{\text{EN}}$	Power Up/Down	Receiver Outputs
0	0	Up	Enable
0	1	Up	Tri-state
1	0	Down	Enable
1	1	Down	Tri-state

Table 3. Wake-Up Truth Table for SP2xxHB

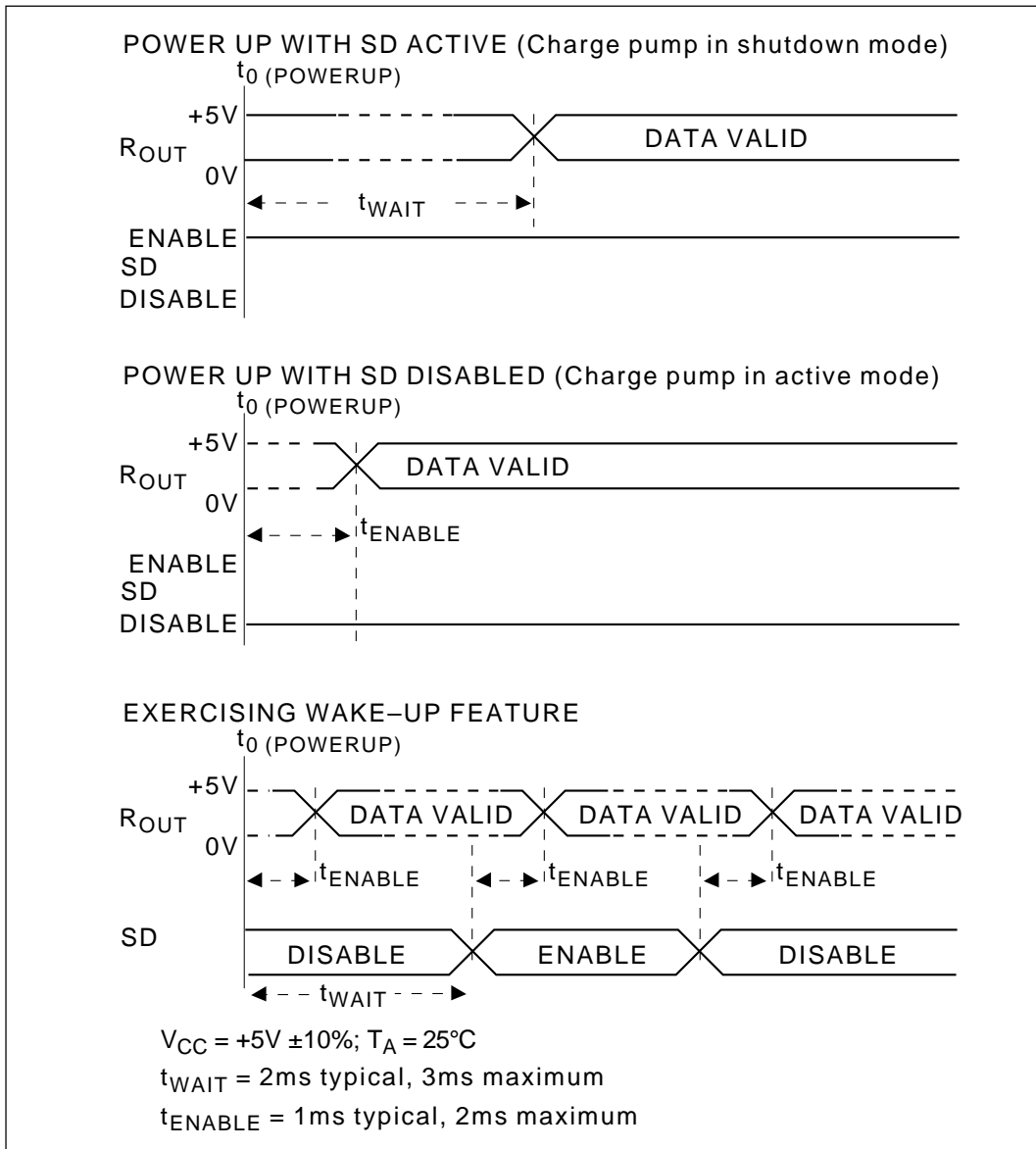
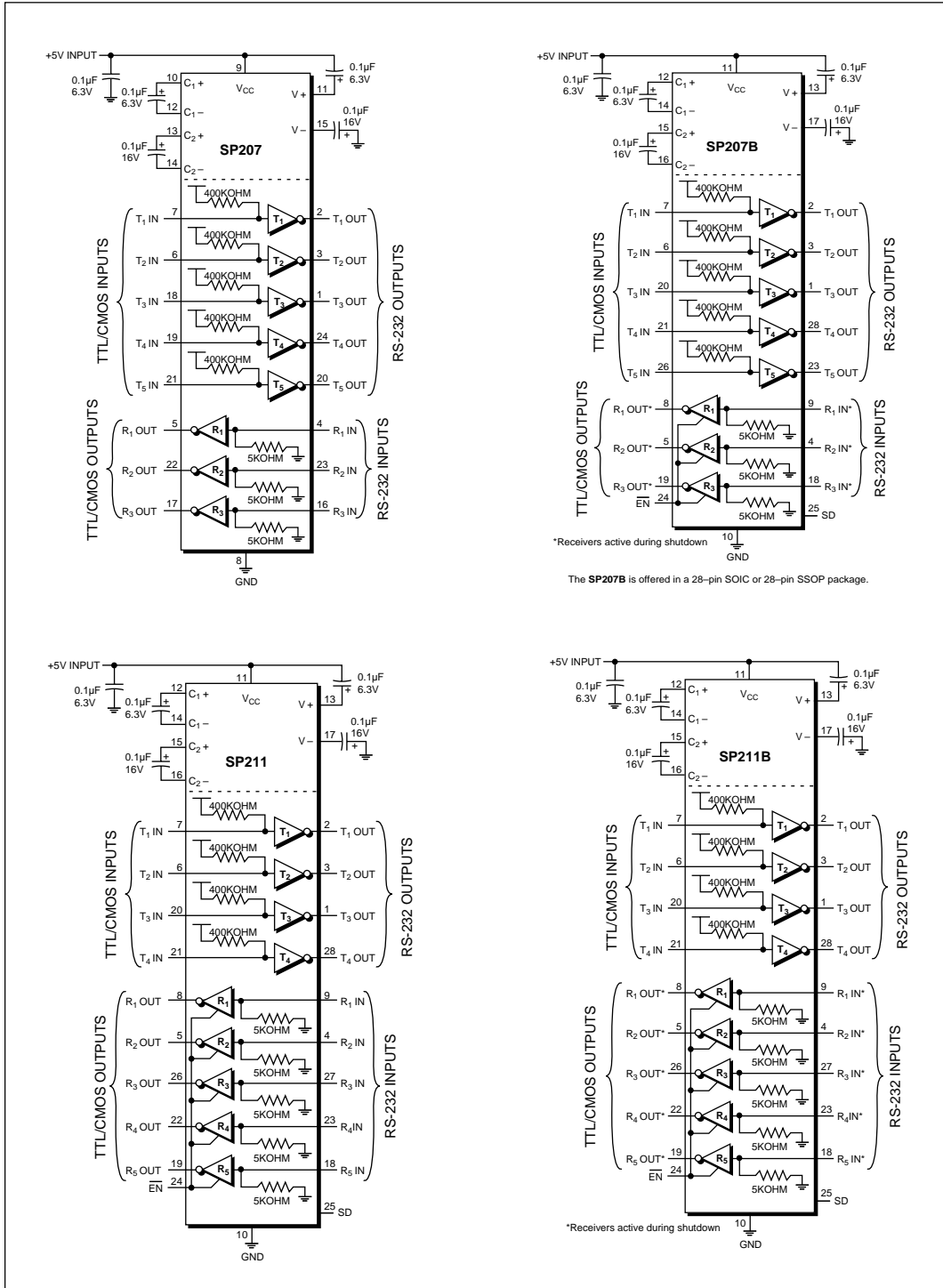
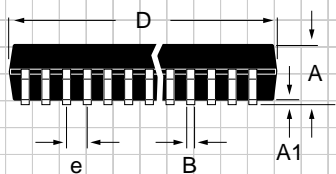
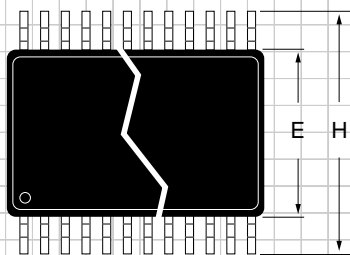

Figure 6. Wake-Up Timing

TYPICAL APPLICATION CIRCUITS



**PACKAGE: PLASTIC SHRINK
SMALL OUTLINE
(SSOP)**



DIMENSIONS (Inches) Minimum/Maximum (mm)	24-PIN	28-PIN				
A	0.068/0.078 (1.73/1.99)	0.068/0.078 (1.73/1.99)				
A1	0.002/0.008 (0.05/0.21)	0.002/0.008 (0.05/0.21)				
B	0.010/0.015 (0.25/0.38)	0.010/0.015 (0.25/0.38)				
D	0.317/0.328 (8.07/8.33)	0.397/0.407 (10.07/10.33)				
E	0.205/0.212 (5.20/5.38)	0.205/0.212 (5.20/5.38)				
e	0.0256 BSC (0.65 BSC)	0.0256 BSC (0.65 BSC)				
H	0.301/0.311 (7.65/7.90)	0.301/0.311 (7.65/7.90)				
L	0.022/0.037 (0.55/0.95)	0.022/0.037 (0.55/0.95)				
Ø	0°/8° (0°/8°)	0°/8° (0°/8°)				

**PACKAGE: PLASTIC
SMALL OUTLINE (SOIC)
(WIDE)**

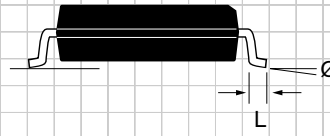
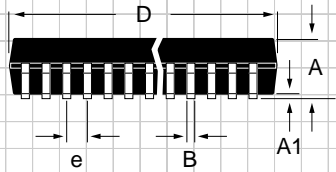
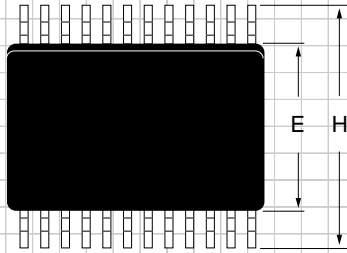

DIMENSIONS (Inches) Minimum/Maximum (mm)	14-PIN	16-PIN	18-PIN	20-PIN	24-PIN	28-PIN
A	0.093/0.104 (2.352/2.649)	0.093/0.104 (2.352/2.649)	0.093/0.104 (2.352/2.649)	0.093/0.104 (2.352/2.649)	0.093/0.104 (2.352/2.649)	0.093/0.104 (2.352/2.649)
A1	0.004/0.012 (0.102/0.300)	0.004/0.012 (0.102/0.300)	0.004/0.012 (0.102/0.300)	0.004/0.012 (0.102/0.300)	0.004/0.012 (0.102/0.300)	0.004/0.012 (0.102/0.300)
B	0.013/0.020 (0.330/0.508)	0.013/0.020 (0.330/0.508)	0.013/0.020 (0.330/0.508)	0.013/0.020 (0.330/0.508)	0.013/0.020 (0.330/0.508)	0.013/0.020 (0.330/0.508)
D	0.348/0.363 (8.83/9.22)	0.398/0.413 (10.10/10.49)	0.447/0.463 (11.35/11.74)	0.496/0.512 (12.60/13.00)	0.599/0.614 (15.20/15.59)	0.697/0.713 (17.70/18.09)
E	0.291/0.299 (7.402/7.600)	0.291/0.299 (7.402/7.600)	0.291/0.299 (7.402/7.600)	0.291/0.299 (7.402/7.600)	0.291/0.299 (7.402/7.600)	0.291/0.299 (7.402/7.600)
e	0.050 BSC (1.270 BSC)	0.050 BSC (1.270 BSC)	0.050 BSC (1.270 BSC)	0.050 BSC (1.270 BSC)	0.050 BSC (1.270 BSC)	0.050 BSC (1.270 BSC)
H	0.394/0.419 (10.00/10.64)	0.394/0.419 (10.00/10.64)	0.394/0.419 (10.00/10.64)	0.394/0.419 (10.00/10.64)	0.394/0.419 (10.00/10.64)	0.394/0.419 (10.00/10.64)
L	0.016/0.050 (0.406/1.270)	0.016/0.050 (0.406/1.270)	0.016/0.050 (0.406/1.270)	0.016/0.050 (0.406/1.270)	0.016/0.050 (0.406/1.270)	0.016/0.050 (0.406/1.270)
Ø	0°/8° (0°/8°)	0°/8° (0°/8°)	0°/8° (0°/8°)	0°/8° (0°/8°)	0°/8° (0°/8°)	0°/8° (0°/8°)

**PACKAGE: PLASTIC
DUAL-IN-LINE
(NARROW)**

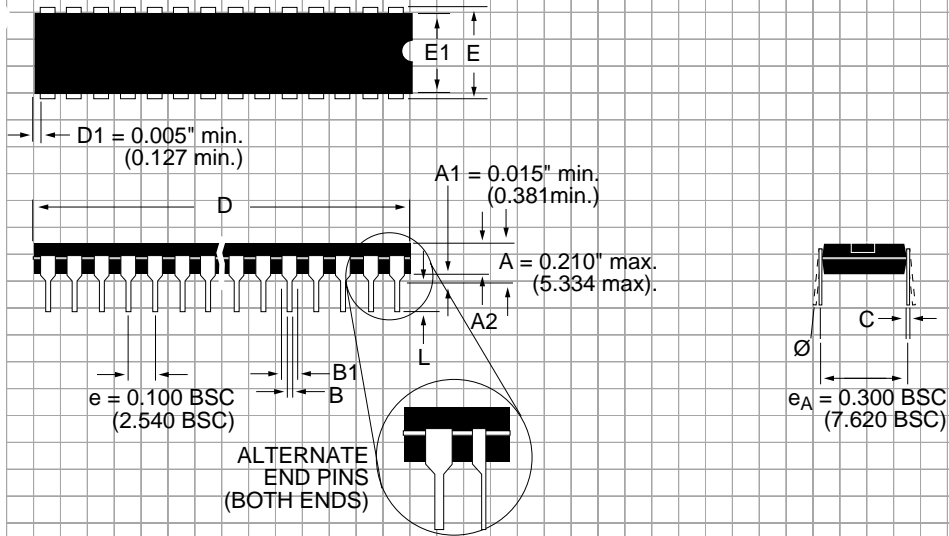

DIMENSIONS (Inches) Minimum/Maximum (mm)	8-PIN	14-PIN	16-PIN	18-PIN	20-PIN	22-PIN
A2	0.115/0.195 (2.921/4.953)	0.115/0.195 (2.921/4.953)	0.115/0.195 (2.921/4.953)	0.115/0.195 (2.921/4.953)	0.115/0.195 (2.921/4.953)	0.115/0.195 (2.921/4.953)
B	0.014/0.022 (0.356/0.559)	0.014/0.022 (0.356/0.559)	0.014/0.022 (0.356/0.559)	0.014/0.022 (0.356/0.559)	0.014/0.022 (0.356/0.559)	0.014/0.022 (0.356/0.559)
B1	0.045/0.070 (1.143/1.778)	0.045/0.070 (1.143/1.778)	0.045/0.070 (1.143/1.778)	0.045/0.070 (1.143/1.778)	0.045/0.070 (1.143/1.778)	0.045/0.070 (1.143/1.778)
C	0.008/0.014 (0.203/0.356)	0.008/0.014 (0.203/0.356)	0.008/0.014 (0.203/0.356)	0.008/0.014 (0.203/0.356)	0.008/0.014 (0.203/0.356)	0.008/0.014 (0.203/0.356)
D	0.355/0.400 (9.017/10.160)	0.735/0.775 (18.669/19.685)	0.780/0.800 (19.812/20.320)	0.880/0.920 (22.352/23.368)	0.980/1.060 (24.892/26.924)	1.145/1.155 (29.083/29.337)
E	0.300/0.325 (7.620/8.255)	0.300/0.325 (7.620/8.255)	0.300/0.325 (7.620/8.255)	0.300/0.325 (7.620/8.255)	0.300/0.325 (7.620/8.255)	0.300/0.325 (7.620/8.255)
E1	0.240/0.280 (6.096/7.112)	0.240/0.280 (6.096/7.112)	0.240/0.280 (6.096/7.112)	0.240/0.280 (6.096/7.112)	0.240/0.280 (6.096/7.112)	0.240/0.280 (6.096/7.112)
L	0.115/0.150 (2.921/3.810)	0.115/0.150 (2.921/3.810)	0.115/0.150 (2.921/3.810)	0.115/0.150 (2.921/3.810)	0.115/0.150 (2.921/3.810)	0.115/0.150 (2.921/3.810)
\emptyset	0°/15° (0°/15°)	0°/15° (0°/15°)	0°/15° (0°/15°)	0°/15° (0°/15°)	0°/15° (0°/15°)	0°/15° (0°/15°)

**PACKAGE: PLASTIC
DUAL-IN-LINE
(NARROW)**

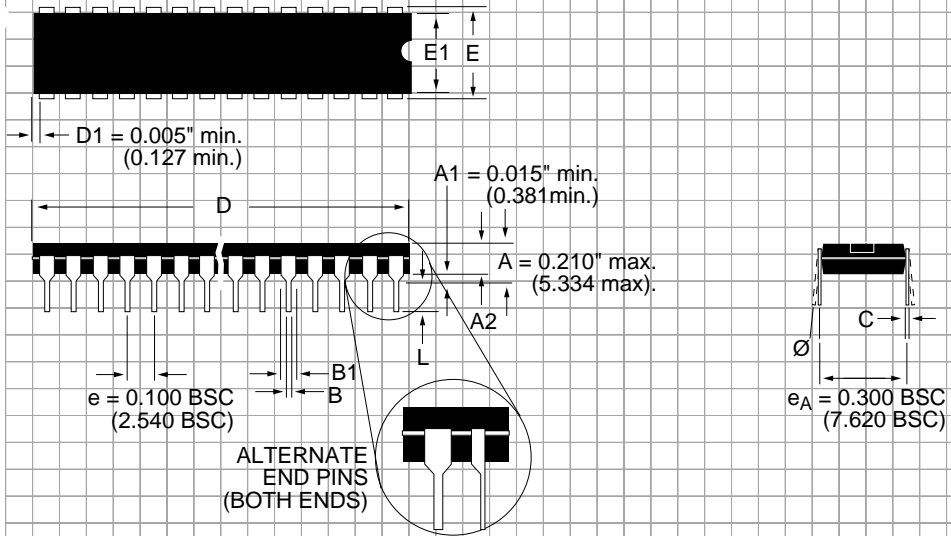

DIMENSIONS (Inches) Minimum/Maximum (mm)	24-PIN	28-PIN				
A2	0.115/0.195 (2.921/4.953)	0.115/0.195 (2.921/4.953)				
B	0.014/0.022 (0.356/0.559)	0.014/0.022 (0.356/0.559)				
B1	0.045/0.070 (1.143/1.778)	0.045/0.070 (1.143/1.778)				
C	0.008/0.014 (0.203/0.356)	0.008/0.014 (0.203/0.356)				
D	1.230/1.280 (31.24/32.51)	1.385/1.405 (35.179/35.687)				
E	0.300/0.325 (7.620/8.255)	0.300/0.325 (7.620/8.255)				
E1	0.240/0.280 (6.096/7.112)	0.240/0.280 (6.096/7.112)				
L	0.115/0.150 (2.921/3.810)	0.115/0.150 (2.921/3.810)				
\emptyset	0°/15° (0°/15°)	0°/15° (0°/15°)				

ORDERING INFORMATION

RS232 Transceivers:

Model	Drivers	Receivers	Temperature Range	Package Type
SP207HCA	5	3	0°C to +70°C	24-pin SSOP
SP207HCP	5	3	0°C to +70°C	24-pin Plastic DIP
SP207HCT	5	3	0°C to +70°C	24-pin SOIC
SP207HEA	5	3	-40°C to +85°C	24-pin SSOP
SP207HEP	5	3	-40°C to +85°C	24-pin Plastic DIP
SP207HET	5	3	-40°C to +85°C	24-pin SOIC

RS232 Transceivers with Low-Power Shutdown and Tri-state Enable:

Model	Drivers	Receivers	Temperature Range	Package Type
SP211HCA	4	5	0°C to +70°C	28-pin SSOP
SP211HCT	4	5	0°C to +70°C	28-pin SOIC
SP211HEA	4	5	-40°C to +85°C	28-pin SSOP
SP211HET	4	5	-40°C to +85°C	28-pin SOIC

RS232 Transceivers with Low-Power Shutdown, Tri-state Enable, and Wake-Up Function:

Model	Drivers	Receivers	Temperature Range	Package Type
SP207HBCA	5	3, with 3 active in Shutdown	0°C to +70°C	28-pin SSOP
SP207HBCT	5	3, with 3 active in Shutdown	0°C to +70°C	28-pin SOIC
SP207HBEA	5	3, with 3 active in Shutdown	-40°C to +85°C	28-pin SSOP
SP207HBET	5	3, with 3 active in Shutdown	-40°C to +85°C	28-pin SOIC
SP211HBCA	4	5, with 5 active in Shutdown	0°C to +70°C	28-pin SSOP
SP211HBCT	4	5, with 5 active in Shutdown	0°C to +70°C	28-pin SOIC
SP211HBEA	4	5, with 5 active in Shutdown	-40°C to +85°C	28-pin SSOP
SP211HBET	4	5, with 5 active in Shutdown	-40°C to +85°C	28-pin SOIC



SIGNAL PROCESSING EXCELLENCE

Sipex Corporation

**Headquarters and
Sales Office**
22 Linnell Circle
Billerica, MA 01821
TEL: (978) 667-8700
FAX: (978) 670-9001
e-mail: sales@sipex.com

Sales Office
233 South Hillview Drive
Milpitas, CA 95035
TEL: (408) 934-7500
FAX: (408) 935-7600

Sipex Corporation reserves the right to make changes to any products described herein. Sipex does not assume any liability arising out of the application or use of any product or circuit described herein; neither does it convey any license under its patent rights nor the rights of others.