

AN5769

H/V convergence correction IC

■ Overview

The AN5769 is an IC to correct convergence in horizontal and vertical directions. It is possible to allow ± 100 mA (max.) DC current flow by connecting a coil between the output pins which operate with the reverse phase each other.

■ Features

- DC control input 0 V to 5 V
- Output dynamic range 1.2 V to 3.8 V
- Maximum output current ± 100 mA

■ Applications

- CRT monitors

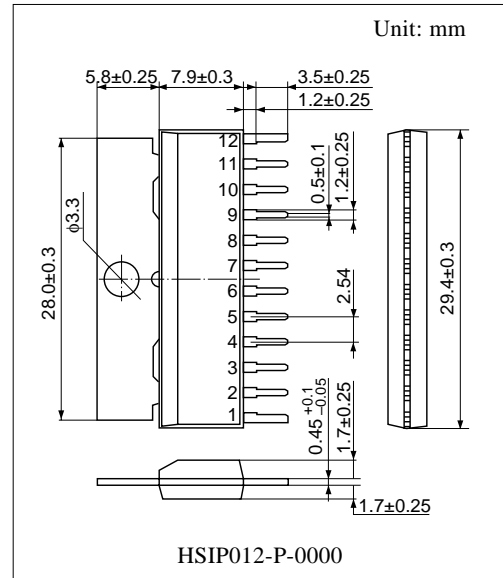

■ Block Diagram

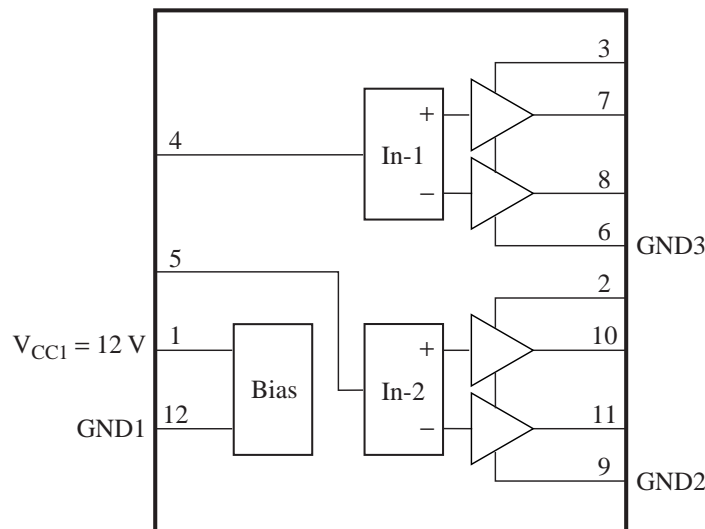

■ Pin Descriptions

Pin No.	Description	Pin No.	Description
1	Power supply 12 V (V_{CC1})	6	Output block GND (GND3)
2	Output block power supply 7 V (V_{CC2}), protection resistor is required.	7	H-conv. positive output
		8	H-conv. negative output
3	Output block power supply 7 V (V_{CC3}), protection resistor is required.	9	Output block GND (GND2)
		10	V-conv. positive output
4	H-conv. control input	11	V-conv. negative output
5	V-conv. control input	12	GND (GND1)

■ Absolute Maximum Ratings

Parameter	Symbol	Rating	Unit
Supply voltage	V_{CC1}	13.5	V
	V_{CC2}	11.05	
	V_{CC3}	11.05	
Supply current	I_{CC1}	28	mA
	I_{CC2}	150	
	I_{CC3}	150	
Power dissipation ^{*2}	P_D	1 171	mW
Operating ambient temperature ^{*1}	T_{opr}	-25 to +75	°C
Storage temperature ^{*1}	T_{stg}	-55 to +150	°C

Note) 1. ^{*1}: Except for the operating ambient temperature and storage temperature, all ratings are for $T_a = 25^\circ\text{C}$.

^{*2}: The power dissipation shown is for the IC package at $T_a = 75^\circ\text{C}$.

2. Pay attention to a breakdown to be caused by static electricity for pin 1.

3. Observe the following order of the supply power start-up:

- Turn-on order First: Pin 2, pin 3 on (7 V) power supply
 Second: Pin 1 on (12 V) power supply
- Turn-off order First: Pin 1 off (12 V) power supply
 Second: Pin 2, pin 3 off (7 V) power supply

■ Recommended Operating Range

Parameter	Symbol	Range	Unit
Supply voltage	V_{CC1}	10.8 to 13.2	V
	V_{CC2}	6.0 to 9.0	
	V_{CC3}	6.0 to 9.0	

■ Electrical Characteristics at $T_a = 25^\circ\text{C}$

Parameter	Symbol	Conditions	Min	Typ	Max	Unit
Circuit current 1	I_{CC1}	$V_{CC1} = 12\text{ V}, V_{CC2} = V_{CC3} = 7\text{ V}$	17	22	27	mA
Circuit current 2	I_{CC2}	$V_{CC1} = 12\text{ V}, V_{CC2} = V_{CC3} = 7\text{ V}$	—	0	1	mA
Circuit current 3	I_{CC3}	$V_{CC1} = 12\text{ V}, V_{CC2} = V_{CC3} = 7\text{ V}$	—	0	1	mA
Circuit voltage 7	V_{7-6}	$V_{CC1} = 12\text{ V}, V_{CC2} = V_{CC3} = 7\text{ V}$	2.8	3.0	3.2	V
Circuit voltage 8	V_{8-6}	$V_{CC1} = 12\text{ V}, V_{CC2} = V_{CC3} = 7\text{ V}$	2.8	3.0	3.2	V
Circuit voltage 10	V_{10-9}	$V_{CC1} = 12\text{ V}, V_{CC2} = V_{CC3} = 7\text{ V}$	2.8	3.0	3.2	V
Circuit voltage 11	V_{11-9}	$V_{CC1} = 12\text{ V}, V_{CC2} = V_{CC3} = 7\text{ V}$	2.8	3.0	3.2	V
H-conv. output voltage 1	E_{H1}	$V_7 - V_8$ at $V_4 = 2.5\text{ V}$	-0.15	0	+0.15	V
H-conv. output voltage 2	E_{H2}	$V_7 - V_8$ at $V_4 = 5\text{ V}$	+2.3	+2.5	+2.7	V
H-conv. output voltage 3	E_{H3}	$V_7 - V_8$ at $V_4 = 0\text{ V}$	-2.7	-2.5	-2.3	V
V-conv. output voltage 1	E_{V1}	$V_{10} - V_{11}$ at $V_5 = 2.5\text{ V}$	-0.15	0	+0.15	V
V-conv. output voltage 2	E_{V2}	$V_{10} - V_{11}$ at $V_5 = 5\text{ V}$	+2.3	+2.5	+2.7	V
V-conv. output voltage 3	E_{V3}	$V_{10} - V_{11}$ at $V_5 = 0\text{ V}$	-2.7	-2.5	-2.3	V

• Design reference data

Note) The characteristics listed below are theoretical values based on the IC design and are not guaranteed.

Parameter	Symbol	Conditions	Min	Typ	Max	Unit
High-level H-conv. output fluctuation with supply voltage	$\Delta E_{H/VCCH}$	ΔE with V_{CC1} change 12 V to 13.2 V, and V_{CC2}, V_{CC3} from 7 V to 9 V	-0.1	—	+0.1	V
Low-level H-conv. output fluctuation with supply voltage	$\Delta E_{H/VCCL}$	ΔE with V_{CC1} change 12 V to 10.8 V, and V_{CC2}, V_{CC3} from 7 V to 6 V	-0.1	—	+0.1	V
High-level V-conv. output fluctuation with supply voltage	$\Delta E_{V/VCCH}$	ΔE with V_{CC1} change 12 V to 13.2 V, and V_{CC2}, V_{CC3} from 7 V to 9 V	-0.1	—	+0.1	V
Low-level V-conv. output fluctuation with supply voltage	$\Delta E_{V/VCCL}$	ΔE with V_{CC1} change 12 V to 10.8 V, and V_{CC2}, V_{CC3} from 7 V to 6 V	-0.1	—	+0.1	V
H-conv. output fluctuation with temperature	$\Delta E_{H/Ta}$	ΔE with T_a change from $+25^\circ\text{C}$ to $+70^\circ\text{C}$ and with T_a change from $+25^\circ\text{C}$ to -20°C	-0.1	—	+0.1	V
V-conv. output fluctuation with temperature	$\Delta E_{V/Ta}$	ΔE with T_a change from $+25^\circ\text{C}$ to $+70^\circ\text{C}$ and with T_a change from $+25^\circ\text{C}$ to -20°C	-0.1	—	+0.1	V

■ Terminal Equivalent Circuits

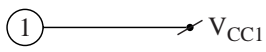
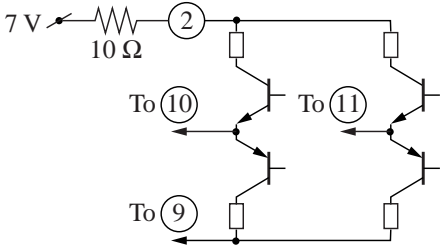
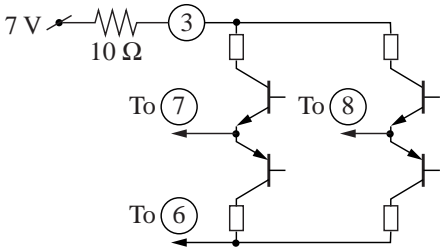
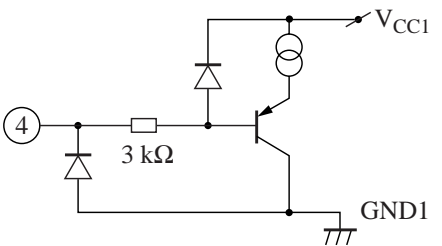
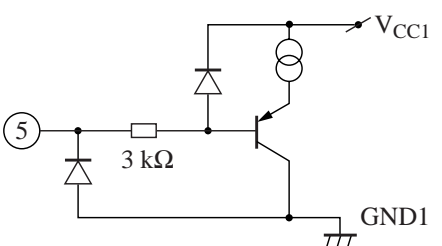
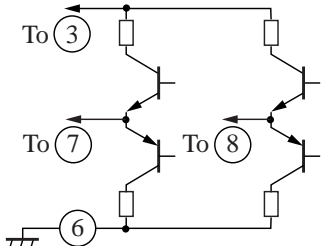
Pin No.	Equivalent circuit	Description	DC voltage (V)
1		Power supply 12 V (V_{CC1}): Power supply pin Apply DC 12 V.	12
2		Output block power supply 7 V (V_{CC2}): Power supply pin for V-conv. output Apply DC 7 V via protective resistor.	7
3		Output block power supply 7 V (V_{CC3}): Power supply pin for H-conv. output Apply DC 7 V via protective resistor.	7
4		H-conv. control input: Control input for H-conv. Apply DC 0 V to 5 V. (typ. = 2.5 V)	—
5		V-conv. control input: Control input for V-conv. Apply DC 0 V to 5 V. (typ. = 2.5 V)	—
6		GND3: Grounding pin of H-conv. output block	0

■ Terminal Equivalent Circuits (continued)

Pin No.	Equivalent circuit	Description	DC voltage (V)
7		<p>H-conv. positive output: Positive output pin for H-conv. Outputs polarity as same as that of pin 4.</p>	1.7 to 4.2
8		<p>H-conv. negative output: Negative output pin for H-conv. Outputs polarity opposite to that of pin 4.</p>	1.7 to 4.2
9		<p>GND2: Grounding pin of V-conv. output block</p>	0
10		<p>V-conv. positive output: Positive output pin for V-conv. Outputs polarity as same as that of pin 5.</p>	1.7 to 4.2
11		<p>V-conv. negative output: Negative output pin for V-conv. Outputs polarity opposite to that of pin 5.</p>	1.7 to 4.2
12		<p>GND1: Grounding pin for 12V-system</p>	0

■ Application Circuit Example

