

## *Advance Information* **Low Voltage PLL Clock Driver**

The MPC932 is a 3.3V compatible PLL based clock driver device targeted for zero delay applications. The device provides 6 outputs for driving clock loads plus a single dedicated PLL feedback clock output. The dedicated feedback output gives the user six choices of input multiplication factors: x1, x1.25, x1.5, x2, x2.5 and x3.

- 6 Low Skew Clock Outputs
- 1 Dedicated PLL Feedback Output
- Individual Output Enable Control
- Fully Integrated PLL
- Output Frequency Up TO 120MHz
- 32-lead TQFP Packaging
- 3.3V VCC
- $\pm 100$ ps Cycle-Cycle Jitter

The MPC932 provides individual output enable control. The enables are synchronized to the internal clock such that upon assertion the shut down signals will hold the clocks LOW without generating a runt pulse on the outputs. The shut down pins provide a means of powering down certain portions of a system or a means of disabling outputs when the full compliment are not required for a specific design. The shut down pins will disable the outputs when driven LOW. A common shut down pin is provided to disable all of the outputs (except the feedback output) with a single control signal.

Two feedback select pins are provided to select the multiplication factor of the PLL. The MPC932 provides six multiplication factors: x1, x1.25, x1.5, x2, x2.5 and x3. In the x1.25 and x2.5 modes, the QFB output will not provide a 50% duty cycle. The phase detector of the MPC932 only monitors rising edges of its feedback signals, thus for this function a 50% duty cycle is not required. As the QFB signal can also be used to drive other clocks in a system it is important the user understand that the duty cycle will not be 50%. In the x1 and x1.5 modes the QFB output will produce 50% duty cycle signals.

The MPC932 provides two pins for use in system test and debug operations. The MR/OE input will force all of the outputs into a high impedance state to allow for back driving the outputs during system test. In addition the PLL\_EN pin allows the user to bypass the PLL and drive the outputs directly through the Ref\_CLK input. Note the Ref\_CLK signal will be routed through the dividers so that it will take several transitions on the Ref\_CLK input to create a transition on the outputs.

The MPC932 is fully 3.3V compatible and requires no external loop filter components. All of the inputs are LVCMOS/LVTTL compatible and the outputs produce rail-to-rail 3.3V swings. For series terminated applications each output can drive two series terminated 50 $\Omega$  transmission lines. For parallel terminated lines the device can drive terminations of 50 $\Omega$  into VCC/2. The device is packaged in a 32-lead TQFP package to provide the optimum combination of performance, board density and cost.

**MPC932**

**LOW VOLTAGE  
PLL CLOCK DRIVER**

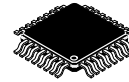

**FA SUFFIX**  
TQFP PACKAGE  
CASE 873A-02



# MPC932

**Pinout: 32-Lead TQFP Package (Top View)**

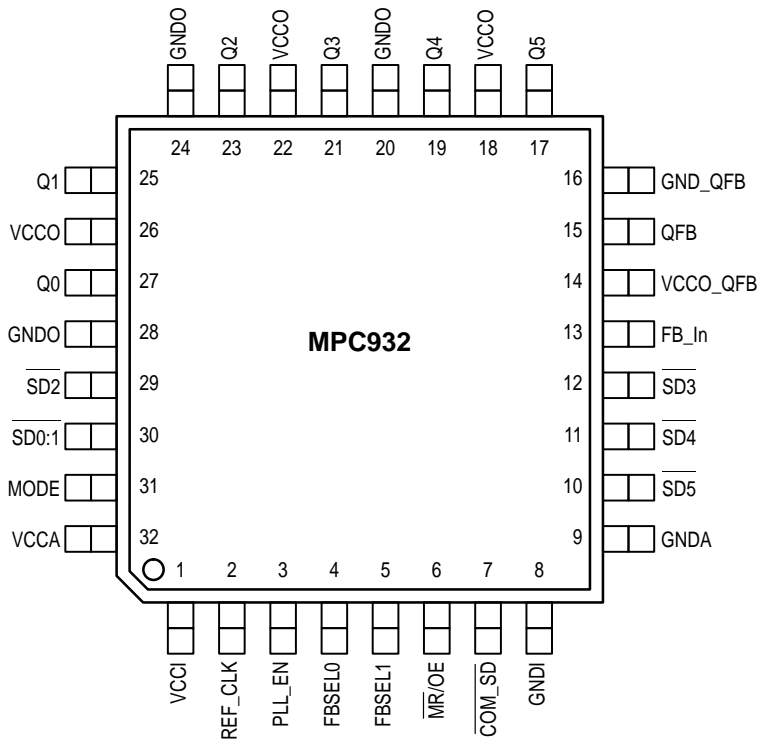

## FUNCTION TABLES

SDn, COM_SD	Qn
0	Held LOW
1	Enabled
PLL_En	PLL Status
0	Test Mode
1	PLL Enabled
MR/OE	PLL Status
0	Disabled
1	Enabled

MODE	FBSEL1	FBSEL0	Qn	QFB
0	0	0	VCO/4	VCO/8
0	0	1	VCO/4	VCO/10
0	1	0	VCO/4	VCO/12
0	1	1	NA	NA
1	0	0	VCO/4	VCO/4
1	0	1	VCO/4	VCO/5
1	1	0	VCO/4	VCO/6
1	1	1	NA	NA

## LOGIC DIAGRAM

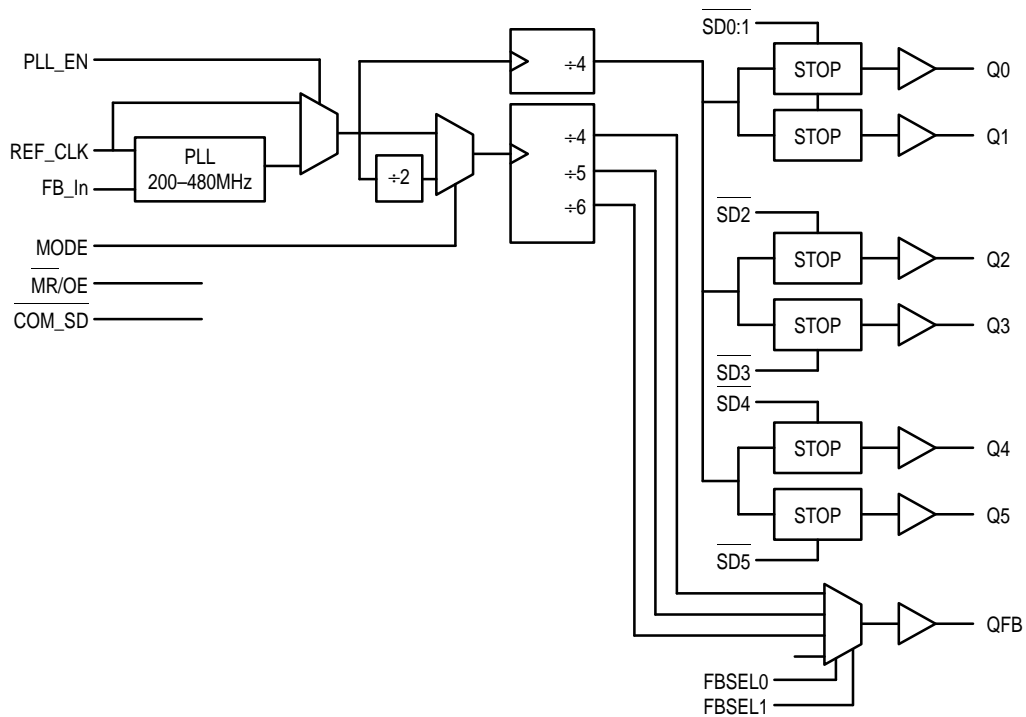



Figure 1. Timing Diagram

**ABSOLUTE MAXIMUM RATINGS\***

Symbol	Parameter	Min	Max	Unit
V <sub>CC</sub>	Supply Voltage	-0.3	4.6	V
V <sub>I</sub>	Input Voltage	-0.3	V <sub>DD</sub> + 0.3	V
I <sub>IN</sub>	Input Current		±20	mA
T <sub>Stor</sub>	Storage Temperature Range	-40	125	°C

\* Absolute maximum continuous ratings are those values beyond which damage to the device may occur. Exposure to these conditions or conditions beyond those indicated may adversely affect device reliability. Functional operation under absolute-maximum-rated conditions is not implied.

**PLL INPUT REFERENCE CHARACTERISTICS (T<sub>A</sub> = 0 to 70°C)**

Symbol	Characteristic	Min	Max	Unit	Condition
t <sub>r</sub> , t <sub>f</sub>	TCLK Input Rise/Falls		3.0	ns	
f <sub>ref</sub>	Reference Input Frequency	Note 1.	Note 1.	MHz	
f <sub>refDC</sub>	Reference Input Duty Cycle	25	75	%	

1. Maximum and Maximum input reference frequency is limited by the VCO lock range and the feedback divider.

**DC CHARACTERISTICS (T<sub>A</sub> = 0° to 70°C, V<sub>CC</sub> = 3.3V ±5%)**

Symbol	Characteristic	Min	Typ	Max	Unit	Condition
V <sub>IH</sub>	Input HIGH Voltage	2.0		3.6	V	
V <sub>IL</sub>	Input LOW Voltage			0.8	V	
V <sub>OH</sub>	Output HIGH Voltage	2.4			V	I <sub>OH</sub> = -20mA (Note 2.)
V <sub>OL</sub>	Output LOW Voltage			0.5	V	I <sub>OL</sub> = 20mA (Note 2.)
I <sub>IN</sub>	Input Current			±120	μA	Note 3.
I <sub>CC</sub>	Maximum Core Supply Current			100	mA	
I <sub>CCPLL</sub>	Maximum PLL Supply Current		15	20	mA	
C <sub>IN</sub>				4	pF	
C <sub>pd</sub>			25		pF	Per Output

2. The MPC932 outputs can drive series or parallel terminated 50Ω (or 50Ω to V<sub>CC</sub>/2) transmission lines on the incident edge (see Applications Info section).

3. Inputs have pull-up/pull-down resistors which affect input current.

**MPC932 AC CHARACTERISTICS** ( $T_A = 0^\circ$  to  $70^\circ\text{C}$ ,  $V_{CC} = 3.3\text{V} \pm 5\%$ )

Symbol	Characteristic	Min	Typ	Max	Unit	Condition
$f_{ref}$	Input Reference Frequency	Note 6.		Note 6.	MHz	
$t_{os}$	Output-to-Output Skew		200	300	ps	Note 4.
$f_{VCO}$	VCO Lock Range	200		480	MHz	
$f_{max}$	Maximum Output Frequency	(+4) (+5) (+6)		120 96 80	MHz	
$t_{pd}$	Reference to EXT_FB Average Delay TCLK PECL_CLK	X - 150	X	X + 150	ps	$f_{ref} = 50\text{MHz}$ ; Note 7.
$t_{pw}$	Output Duty Cycle (Note 4.)	$t_{CYCLE}/2$ -750	$t_{CYCLE}/2$ $\pm 500$	$t_{CYCLE}/2$ +750	ps	
$t_r, t_f$	Output Rise/Fall Time (Note 4.)	0.1		1.0	ns	0.8 to 2.0V
$t_{PLZ}, t_{PHZ}$	Output Disable Time	2.0		8.0	ns	$50\Omega$ to $V_{CC}/2$
$t_{PZL}$	Output Enable Time	2.0		10	ns	$50\Omega$ to $V_{CC}/2$
$t_{jitter}$	Cycle-to-Cycle Jitter (Peak-to-Peak)		$\pm 100$		ps	Note 5.
$t_{lock}$	Maximum PLL Lock Time			10	ms	

4. Measured with  $50\Omega$  to  $V_{CC}/2$  termination.
5. See Applications Info section for more jitter information.
6. Input reference frequency is bounded by VCO lock range and feedback divide selection.
7.  $t_{pd}$  measurement uses the averaging feature of the oscilloscope to remove the jitter component.

**APPLICATIONS INFORMATION**

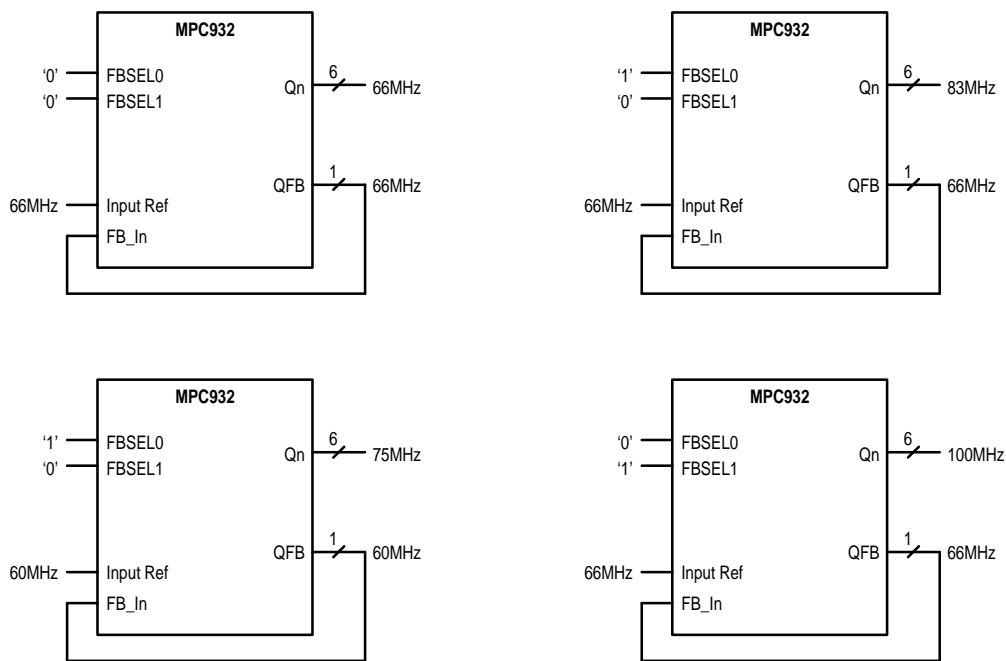

**Figure 2. MPC932 Potential Configurations**  
(Mode = 1)

## Power Supply Filtering

The MPC932 is a mixed analog/digital product and as such it exhibits some sensitivities that would not necessarily be seen on a fully digital product. Analog circuitry is naturally susceptible to random noise, especially if this noise is seen on the power supply pins. The MPC932 provides separate power supplies for the output buffers ( $V_{CCO}$ ) and the internal PLL ( $V_{CCA}$ ) of the device. The purpose of this design technique is to try and isolate the high switching noise digital outputs from the relatively sensitive internal analog phase-locked loop. In a controlled environment such as an evaluation board this level of isolation is sufficient. However, in a digital system environment where it is more difficult to minimize noise on the power supplies a second level of isolation may be required. The simplest form of isolation is a power supply filter on the  $V_{CCA}$  pin for the MPC932.

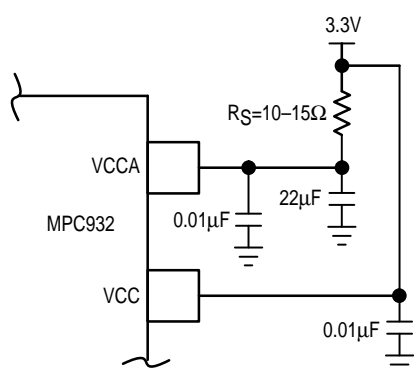

Figure 3. Power Supply Filter

Figure 3 illustrates a typical power supply filter scheme. The MPC932 is most susceptible to noise with spectral content in the 1KHz to 1MHz range. Therefore the filter should be designed to target this range. The key parameter that needs to be met in the final filter design is the DC voltage drop that will be seen between the  $V_{CC}$  supply and the  $V_{CCA}$  pin of the MPC932. From the data sheet the  $I_{V_{CCA}}$  current (the current sourced through the  $V_{CCA}$  pin) is typically 15mA (20mA maximum), assuming that a minimum of 3.0V must be maintained on the  $V_{CCA}$  pin very little DC voltage drop can be tolerated when a 3.3V  $V_{CC}$  supply is used. The resistor shown in Figure 3 must have a resistance of 10–15Ω to meet the voltage drop criteria. The RC filter pictured will provide a broadband filter with approximately 100:1 attenuation for noise whose spectral content is above 20KHz. As the noise frequency crosses the series resonant point of an individual capacitor it's overall impedance begins to look inductive and thus increases with increasing frequency. The parallel capacitor combination shown ensures that a low impedance path to ground exists for frequencies well above the bandwidth of the PLL.

Although the MPC932 has several design features to minimize the susceptibility to power supply noise (isolated power and grounds and fully differential PLL) there still may be applications in which overall performance is being degraded due to system power supply noise. The power supply filter schemes discussed in this section should be

adequate to eliminate power supply noise related problems in most designs.

## Driving Transmission Lines

The MPC932 clock driver was designed to drive high speed signals in a terminated transmission line environment. To provide the optimum flexibility to the user the output drivers were designed to exhibit the lowest impedance possible. With an output impedance of less than 10Ω the drivers can drive either parallel or series terminated transmission lines. For more information on transmission lines the reader is referred to application note AN1091 in the Timing Solutions brochure (BR1333/D).

In most high performance clock networks point-to-point distribution of signals is the method of choice. In a point-to-point scheme either series terminated or parallel terminated transmission lines can be used. The parallel technique terminates the signal at the end of the line with a 50Ω resistance to  $V_{CC}/2$ . This technique draws a fairly high level of DC current and thus only a single terminated line can be driven by each output of the MPC932 clock driver. For the series terminated case however there is no DC current draw, thus the outputs can drive multiple series terminated lines. Figure 4 illustrates an output driving a single series terminated line vs two series terminated lines in parallel. When taken to its extreme the fanout of the MPC932 clock driver is effectively doubled due to its capability to drive multiple lines.

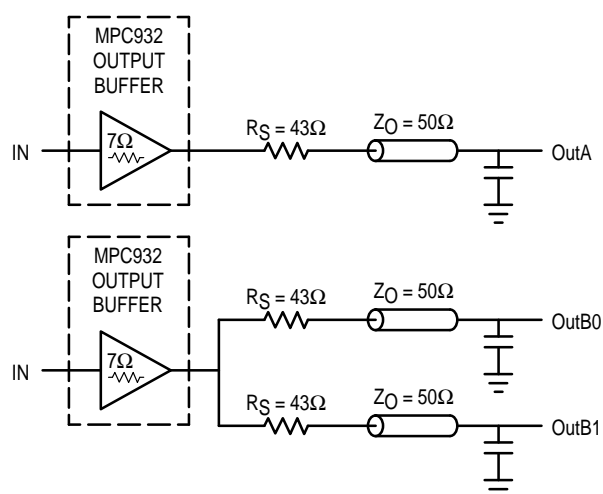

Figure 4. Single versus Dual Transmission Lines

The waveform plots of Figure 5 show the simulation results of an output driving a single line vs two lines. In both cases the drive capability of the MPC932 output buffers is more than sufficient to drive 50Ω transmission lines on the incident edge. Note from the delay measurements in the simulations a delta of only 43ps exists between the two differently loaded outputs. This suggests that the dual line driving need not be used exclusively to maintain the tight output-to-output skew of the MPC932. The output waveform in Figure 5 shows a step in the waveform, this step is caused by the impedance mismatch seen looking into the driver. The parallel combination of the 43Ω series resistor plus the output impedance does not match the parallel combination of the

line impedances. The voltage wave launched down the two lines will equal:

$$V_L = V_S ( Z_0 / (R_s + R_o + Z_0))$$

$$Z_0 = 50\Omega \parallel 50\Omega$$

$$R_s = 43\Omega \parallel 43\Omega$$

$$R_o = 7\Omega$$

$$V_L = 3.0 ( 25 / (21.5 + 7 + 25) ) = 3.0 ( 25 / 53.5 ) = 1.40V$$

At the load end the voltage will double, due to the near unity reflection coefficient, to 2.8V. It will then increment towards the quiescent 3.0V in steps separated by one round trip delay (in this case 4.0ns).

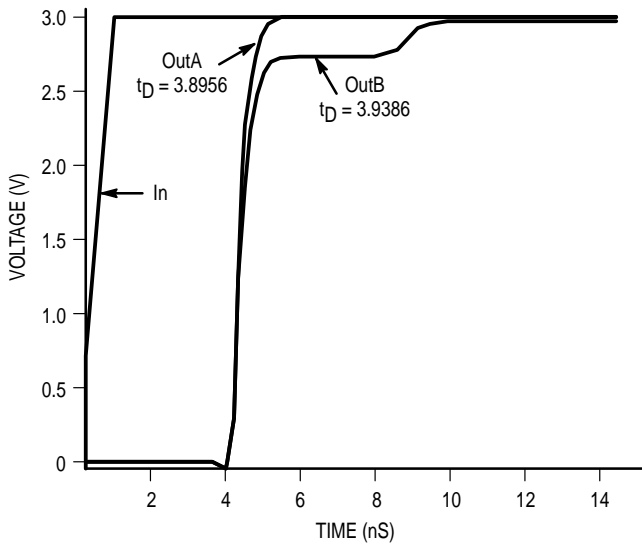

Figure 5. Single versus Dual Waveforms

Since this step is well above the threshold region it will not cause any false clock triggering, however designers may be uncomfortable with unwanted reflections on the line. To better match the impedances when driving multiple lines the situation in Figure 6 should be used. In this case the series terminating resistors are reduced such that when the parallel combination is added to the output buffer impedance the line impedance is perfectly matched.

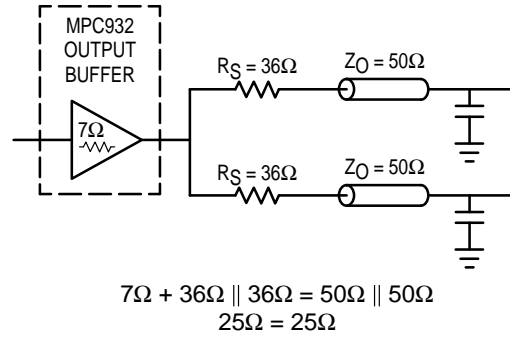
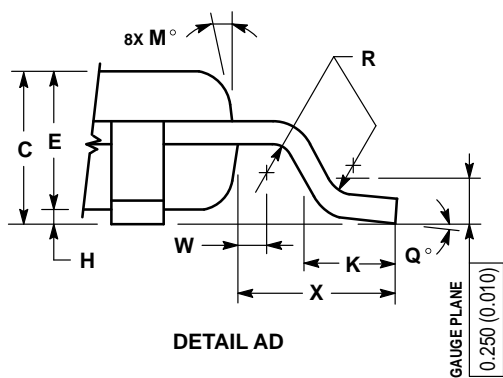
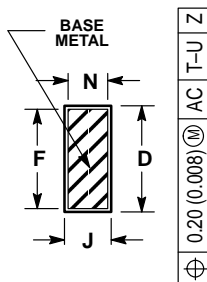
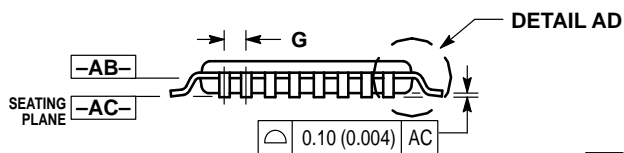
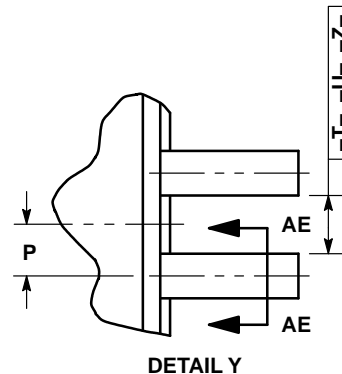
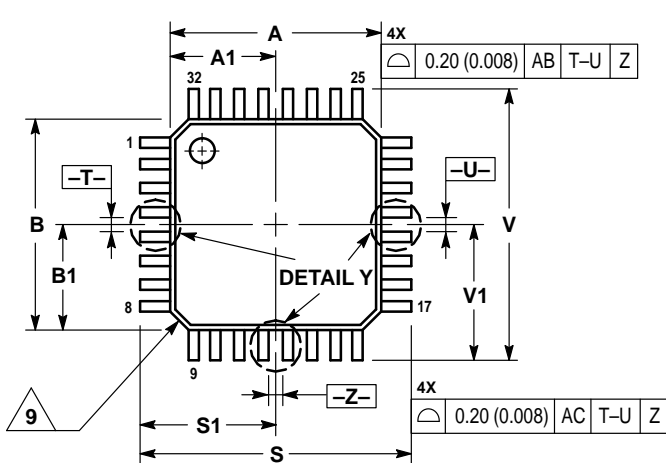

Figure 6. Optimized Dual Line Termination

SPICE level output buffer models are available for engineers who want to simulate their specific interconnect schemes. In addition IV characteristics are in the process of being generated to support the other board level simulators in general use.

OUTLINE DIMENSIONS

FA SUFFIX  
TQFP PACKAGE  
CASE 873A-02  
ISSUE A



NOTES:

1. DIMENSIONING AND TOLERANCING PER ANSI Y14.5M, 1982.
2. CONTROLLING DIMENSION: MILLIMETER.
3. DATUM PLANE -AB- IS LOCATED AT BOTTOM OF LEAD AND IS COINCIDENT WITH THE LEAD WHERE THE LEAD EXITS THE PLASTIC BODY AT THE BOTTOM OF THE PARTING LINE.
4. DATUMS -T-, -U-, AND -Z- TO BE DETERMINED AT DATUM PLANE -AB-.
5. DIMENSIONS S AND V TO BE DETERMINED AT SEATING PLANE -AC-.
6. DIMENSIONS A AND B DO NOT INCLUDE MOLD PROTRUSION. ALLOWABLE PROTRUSION IS 0.250 (0.010) PER SIDE. DIMENSIONS A AND B DO INCLUDE MOLD MISMATCH AND ARE DETERMINED AT DATUM PLANE -AB-.
7. DIMENSION D DOES NOT INCLUDE DAMBAR PROTRUSION. DAMBAR PROTRUSION SHALL NOT CAUSE THE D DIMENSION TO EXCEED 0.520 (0.020).
8. MINIMUM SOLDER PLATE THICKNESS SHALL BE 0.0076 (0.0003).
9. EXACT SHAPE OF EACH CORNER MAY VARY FROM DEPICTION.

DIM	MILLIMETERS		INCHES	
	MIN	MAX	MIN	MAX
A	7.000 BSC		0.276 BSC	
A1	3.500 BSC		0.138 BSC	
B	7.000 BSC		0.276 BSC	
B1	3.500 BSC		0.138 BSC	
C	1.400	1.600	0.055	0.063
D	0.300	0.450	0.012	0.018
E	1.350	1.450	0.053	0.057
F	0.300	0.400	0.012	0.016
G	0.800 BSC		0.031 BSC	
H	0.050	0.150	0.002	0.006
J	0.090	0.200	0.004	0.008
K	0.500	0.700	0.020	0.028
M	12° REF		12° REF	
N	0.090	0.160	0.004	0.006
P	0.400 BSC		0.016 BSC	
Q	1°	5°	1°	5°
R	0.150	0.250	0.006	0.010
S	9.000 BSC		0.354 BSC	
S1	4.500 BSC		0.177 BSC	
V	9.000 BSC		0.354 BSC	
V1	4.500 BSC		0.177 BSC	
W	0.200 REF		0.008 REF	
X	1.000 REF		0.039 REF	

Motorola reserves the right to make changes without further notice to any products herein. Motorola makes no warranty, representation or guarantee regarding the suitability of its products for any particular purpose, nor does Motorola assume any liability arising out of the application or use of any product or circuit, and specifically disclaims any and all liability, including without limitation consequential or incidental damages. "Typical" parameters which may be provided in Motorola data sheets and/or specifications can and do vary in different applications and actual performance may vary over time. All operating parameters, including "Typicals" must be validated for each customer application by customer's technical experts. Motorola does not convey any license under its patent rights nor the rights of others. Motorola products are not designed, intended, or authorized for use as components in systems intended for surgical implant into the body, or other applications intended to support or sustain life, or for any other application in which the failure of the Motorola product could create a situation where personal injury or death may occur. Should Buyer purchase or use Motorola products for any such unintended or unauthorized application, Buyer shall indemnify and hold Motorola and its officers, employees, subsidiaries, affiliates, and distributors harmless against all claims, costs, damages, and expenses, and reasonable attorney fees arising out of, directly or indirectly, any claim of personal injury or death associated with such unintended or unauthorized use, even if such claim alleges that Motorola was negligent regarding the design or manufacture of the part. Motorola and  are registered trademarks of Motorola, Inc. Motorola, Inc. is an Equal Opportunity/Affirmative Action Employer.

**How to reach us:**

**USA/EUROPE/Locations Not Listed:** Motorola Literature Distribution;  
P.O. Box 5405; Denver, Colorado 80217. 1-800-441-2447

**Mfax™:** RMFAX0@email.sps.mot.com – TOUCHTONE 602-244-6609  
**INTERNET:** http://Design-NET.com

**JAPAN:** Nippon Motorola Ltd.; Tatsumi-SPD-JLDC, 6F Seibu-Butsuryu-Center,  
3-14-2 Tatsumi Koto-Ku, Tokyo 135, Japan. 81-3-3521-8315

**ASIA/PACIFIC:** Motorola Semiconductors H.K. Ltd.; 8B Tai Ping Industrial Park,  
51 Ting Kok Road, Tai Po, N.T., Hong Kong. 852-26629298

