

AN8849SB

Head amplifier IC for CD-ROM drive (for 24 times speed or more)

■ Overview

The AN8849SB is a head amplifier IC for digital servo. It can configure an efficient CD-ROM system in combination with the MN662752, and allows a full-automatic adjustment of tracking balance-gain-offset and focus balance-gain-offset with fewer external parts.

Built-in functions are a variable equalizer, wide band RF amp. and AGC which meet CAV playback with 24 times speed or more.

■ Features

- Variable equalizer which meets CAV playback with 24 times speed or more CAV playback.
- Wide band RF amp. and AGC ($f_c = 20$ MHz or more $(-3$ dB))
- Balance adjustment function built-in
Focus error amp./tracking error amp.
- CD-RW playback compatible.
Variable gain
Focus error amp./tracking error amp.
(to +16.9 dB)
- OFTR/BDO detection
- APC amp.

■ Applications

- CD/CD-ROM drive

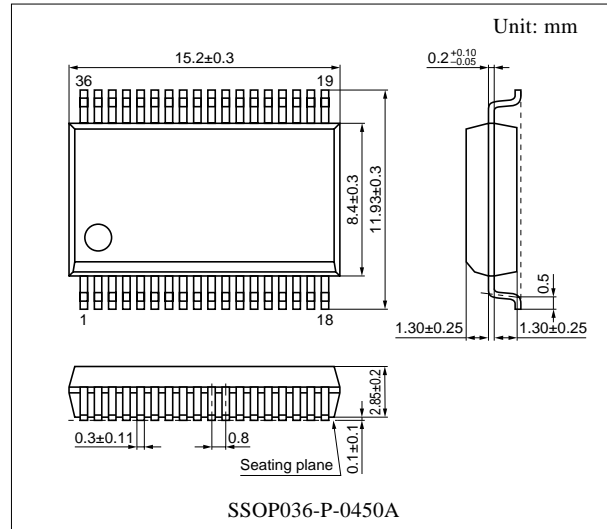

■ Block Diagram

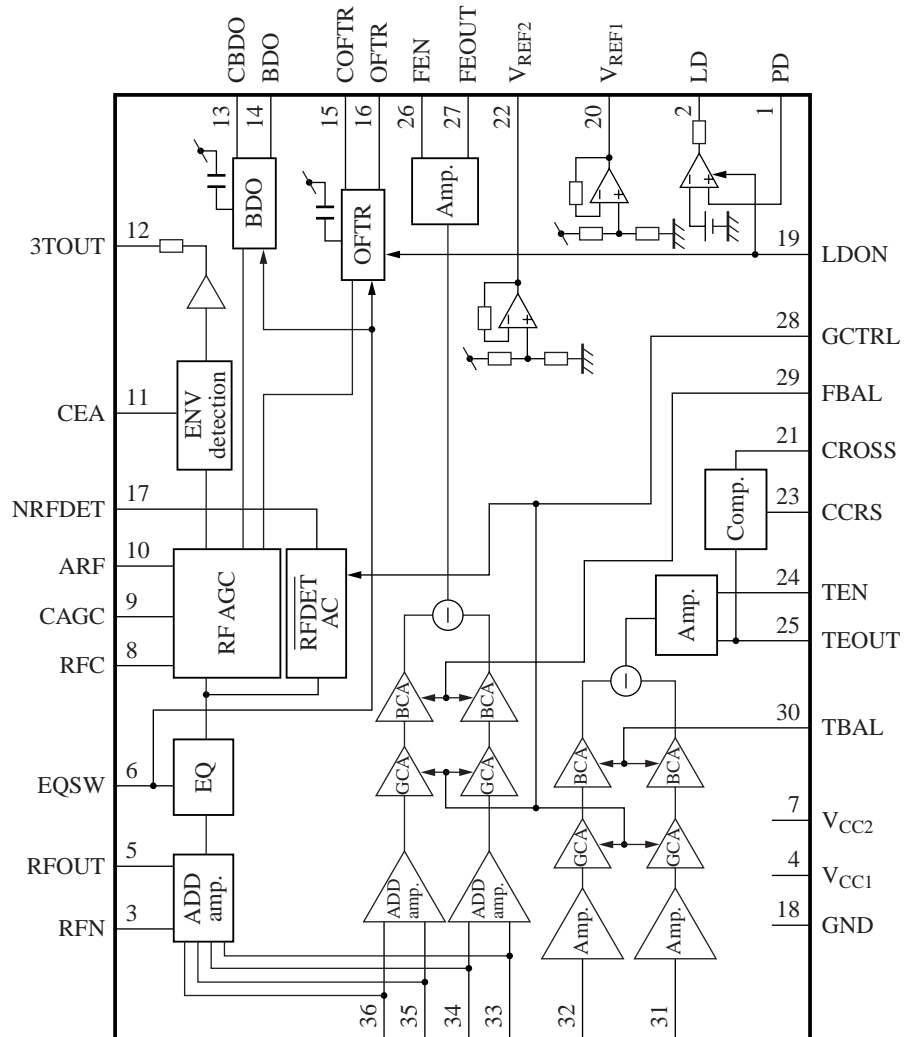

■ Pin Descriptions

Pin No.	Description	Pin No.	Description
1	APC amp. input pin	18	GND pin
2	APC amp. output pin	19	APC & masking control pin
3	RF addition amp. inverted input pin	20	V _{REF1} output pin
4	Power supply pin 1	21	CROSS output pin
5	RF addition amp. output pin	22	V _{REF2} output pin
6	EQ characteristics control pin	23	Capacitor connection pin for CROSS
7	Power supply pin 2	24	TE amp. inverted input pin
8	Capacitor connection pin for HPF of AGC input	25	TE amp. output pin
9	AGC loop filter connection pin	26	FE amp. inverted input pin
10	AGC output pin	27	FE amp. output pin
11	Capacitor connection pin for HPF amp.	28	GCTRL pin
12	3TENV output pin	29	FBAL control pin
13	Capacitor connection pin for RF dark-side envelope detection	30	TBAL control pin
		31	Tracking signal input pin 1
14	BDO output pin	32	Tracking signal input pin 2
15	Capacitor connection pin for RF right-side envelope detection	33	Focus signal input pin 4
		34	Focus signal input pin 2
16	OFTR output pin	35	Focus signal input pin 3
17	NRFDET output pin	36	Focus signal input pin 1

■ Absolute Maximum Ratings

Parameter	Symbol	Rating	Unit
Supply voltage 1 *1	V _{CC1}	5.8	V
Supply voltage 2 *1	V _{CC2}	5.8	V
Supply current 1 *1	I _{CC1}	55	mA
Supply current 2 *1	I _{CC2}	2.5	mA
Power dissipation *1, *2	P _D	333.5	mW
Operating ambient temperature *1	T _{opr}	-20 to +75	°C
Storage temperature *1	T _{stg}	-55 to +125	°C

Note) *1: Except for the power dissipation, operating ambient temperature and storage temperature, all ratings are for T_a = 25°C.

$$*2: P_D = V_{CC1} \cdot I_{CC1} + V_{CC2} \cdot I_{CC2}$$

■ Recommended Operating Range

Parameter	Symbol	Range	Unit
Supply voltage 1	V _{CC1}	4.5 to 5.5	V
Supply voltage 2	V _{CC2}	3.0 to 5.5	V

Note) Apply voltage to satisfy V_{CC2} - V_{CC1} < 0.3 V.

■ Electrical Characteristics at $T_a = 25^\circ\text{C}$

Parameter	Symbol	Conditions	Min	Typ	Max	Unit
Current consumption with no load 1	I_{TOTAL1}	$V_{\text{CC1}} = 5 \text{ V}$, $V_{\text{CC2}} = 3.3 \text{ V}$ $V_{\text{EQSW}} = V_{\text{REF2}} + 0.75 \text{ V}$	28.4	40.6	52.8	mA
Current consumption with no load 2	I_{TOTAL2}	$V_{\text{CC1}} = 5 \text{ V}$, $V_{\text{CC2}} = 3.3 \text{ V}$	1.20	1.72	2.24	mA
V_{REF1} output voltage	V_{REF1}	$V_{\text{CC1}} = 5 \text{ V}$, $V_{\text{CC2}} = 3.3 \text{ V}$	2.27	2.50	2.73	V
V_{REF2} output voltage	V_{REF2}	$V_{\text{CC1}} = 5 \text{ V}$, $V_{\text{CC2}} = 3.3 \text{ V}$	1.50	1.65	1.80	V
Focus error amp.						
Focus error amp. output offset voltage	$V_{\text{FO-OF}}$	$V_{\text{CC1}} = 5 \text{ V}$, $V_{\text{CC2}} = 3.3 \text{ V}$	-90	0	90	mV
Focus error offset balance crosstalk amount	$V_{\text{FO-OFB}}$	$V_{\text{CC1}} = 5 \text{ V}$, $V_{\text{CC2}} = 3.3 \text{ V}$ $V_{\text{FB}} = V_{\text{REF2}} \pm 0.5 \text{ V}$	-150	0	150	mV
Focus error amp. V-V conversion gain	G_{FO}	$V_{\text{CC1}} = 5 \text{ V}$, $V_{\text{CC2}} = 3.3 \text{ V}$ $V_{\text{GC}} = V_{\text{REF2}} - 0.75 \text{ V}$	12.3	14.4	16.5	dB
Focus error amp. V-V conversion relative gain	ΔG_{FO}	$V_{\text{CC1}} = 5 \text{ V}$, $V_{\text{CC2}} = 3.3 \text{ V}$ $V_{\text{GC}} = V_{\text{REF2}} - 0.75 \text{ V}$	-1.5	0	1.5	dB
Focus error amp. balance output 1-H	$B_{\text{FO1-H}}$	$V_{\text{CC1}} = 5 \text{ V}$, $V_{\text{CC2}} = 3.3 \text{ V}$ $V_{\text{FB}} = V_{\text{REF2}} + 0.5 \text{ V}$	1.08	1.35	1.62	—
Focus error amp. balance output 1-L	$B_{\text{FO1-L}}$	$V_{\text{CC1}} = 5 \text{ V}$, $V_{\text{CC2}} = 3.3 \text{ V}$ $V_{\text{FB}} = V_{\text{REF2}} - 0.5 \text{ V}$	0.45	0.65	0.85	—
Focus error amp. balance relative output 2-H	B_{FOH}	$V_{\text{CC1}} = 5 \text{ V}$, $V_{\text{CC2}} = 3.3 \text{ V}$ $V_{\text{FB}} = V_{\text{REF2}} + 0.5 \text{ V}$	4.35	6.35	8.35	dB
Focus error amp. balance relative output 2-L	B_{FOL}	$V_{\text{CC1}} = 5 \text{ V}$, $V_{\text{CC2}} = 3.3 \text{ V}$ $V_{\text{FB}} = V_{\text{REF2}} - 0.5 \text{ V}$	-8.35	-6.35	-4.35	dB
Focus error amp. frequency characteristics	G_{FOF}	$V_{\text{CC1}} = 5 \text{ V}$, $V_{\text{CC2}} = 3.3 \text{ V}$ $f = 3 \text{ kHz}$, 60 kHz	-4.5	-3.0	-1.5	dB
Focus error amp. GCTRL gain ratio $\times 4$	B_{FO4}	$V_{\text{CC1}} = 5 \text{ V}$, $V_{\text{CC2}} = 3.3 \text{ V}$ $V_{\text{GC}} = V_{\text{REF2}}$	3.3	4.3	5.3	—
Tracking error amp.						
Tracking error amp. output offset voltage	$V_{\text{TR-OF}}$	$V_{\text{CC1}} = 5 \text{ V}$, $V_{\text{CC2}} = 3.3 \text{ V}$	-60	0	60	mV
Tracking error offset balance crosstalk amount	$V_{\text{TR-OFB}}$	$V_{\text{CC1}} = 5 \text{ V}$, $V_{\text{CC2}} = 3.3 \text{ V}$ $V_{\text{TB}} = V_{\text{REF2}} \pm 0.5 \text{ V}$	-200	0	200	mV
Tracking error amp. V-V conversion gain	G_{TR}	$V_{\text{CC1}} = 5 \text{ V}$, $V_{\text{CC2}} = 3.3 \text{ V}$ $V_{\text{GC}} = V_{\text{REF2}} - 0.75 \text{ V}$	12.2	14.3	16.4	dB
Tracking error amp. V-V conversion relative gain	ΔG_{TR}	$V_{\text{CC1}} = 5 \text{ V}$, $V_{\text{CC2}} = 3.3 \text{ V}$ $V_{\text{GC}} = V_{\text{REF2}} - 0.75 \text{ V}$	-1.5	0	1.5	dB
Tracking error amp. balance output 1-H	$B_{\text{TR1-H}}$	$V_{\text{CC1}} = 5 \text{ V}$, $V_{\text{CC2}} = 3.3 \text{ V}$ $V_{\text{TB}} = V_{\text{REF2}} + 0.5 \text{ V}$	0.45	0.65	0.85	—
Tracking error amp. balance output 1-L	$B_{\text{TR1-L}}$	$V_{\text{CC1}} = 5 \text{ V}$, $V_{\text{CC2}} = 3.3 \text{ V}$ $V_{\text{TB}} = V_{\text{REF2}} - 0.5 \text{ V}$	1.08	1.35	1.62	—

■ Electrical Characteristics at $T_a = 25^\circ\text{C}$ (continue)

Parameter	Symbol	Conditions	Min	Typ	Max	Unit
Tracking error amp. (continued)						
Tracking error amp. balance relative output 2–H	B_{TRH}	$V_{CC1} = 5\text{ V}$, $V_{CC2} = 3.3\text{ V}$ $V_{TB} = V_{REF2} + 0.5\text{ V}$	–8.35	–6.35	–4.35	dB
Tracking error amp. balance relative output 2–L	B_{TRL}	$V_{CC1} = 5\text{ V}$, $V_{CC2} = 3.3\text{ V}$ $V_{TB} = V_{REF2} - 0.5\text{ V}$	4.35	6.35	8.35	dB
Tracking error amp. frequency characteristics	G_{TRF}	$V_{CC1} = 5\text{ V}$, $V_{CC2} = 3.3\text{ V}$ $f = 30\text{ kHz}$, 500 kHz	–4.5	—	0	dB
Tracking error amp. GCTRL gain ratio $\times 4$	B_{TR4}	$V_{CC1} = 5\text{ V}$, $V_{CC2} = 3.3\text{ V}$ $V_{GC} = V_{REF2}$	3.3	4.3	5.3	—
CROSS detection						
CROSS high-level output	V_{CR-H}	$V_{CC1} = 5\text{ V}$, $V_{CC2} = 3.3\text{ V}$, $f = 10\text{ kHz}$	4.2	—	—	V
CROSS low-level output	V_{CR-L}	$V_{CC1} = 5\text{ V}$, $V_{CC2} = 3.3\text{ V}$, $f = 10\text{ kHz}$	—	—	0.8	V
RF addition amp.						
RF addition amp. output offset voltage	V_{RAOF}	$V_{CC1} = 5\text{ V}$, $V_{CC2} = 3.3\text{ V}$	–200	0	200	mV
RF addition amp. addition gain	G_{RAD}	$V_{CC1} = 5\text{ V}$, $V_{CC2} = 3.3\text{ V}$	–2.1	0	2.1	dB
RF addition amp. addition relative gain 1	ΔG_{RAD1}	$V_{CC1} = 5\text{ V}$, $V_{CC2} = 3.3\text{ V}$	–1.0	0	1.0	dB
RF addition amp. addition relative gain 2	ΔG_{RAD2}	$V_{CC1} = 5\text{ V}$, $V_{CC2} = 3.3\text{ V}$	–1.0	0	1.0	dB
RF addition amp. addition relative gain 3	ΔG_{RAD3}	$V_{CC1} = 5\text{ V}$, $V_{CC2} = 3.3\text{ V}$	–1.0	0	1.0	dB
RF addition amp. full-addition gain	G_{RADA}	$V_{CC1} = 5\text{ V}$, $V_{CC2} = 3.3\text{ V}$	9.9	12.0	14.1	dB
RF addition amp. full-addition frequency characteristics *	G_{RADDF}	$V_{CC1} = 5\text{ V}$, $V_{CC2} = 3.3\text{ V}$ $f = 500\text{ kHz}$, 30 MHz	–3.1	–1.6	1.4	dB
Variable EQ characteristics						
EQ characteristics $\times 1-1$ *	G_{EQ1-1}	$f = 100\text{ kHz}$ $EQSW = V_{REF2} - 0.5\text{ V}$	–1.5	0	1.5	dB
EQ characteristics $\times 1-3$ *	G_{EQ1-3}	$f = 500\text{ kHz}$ $EQSW = V_{REF2} - 0.5\text{ V}$	0.5	2.0	3.5	dB
EQ characteristics $\times 20-1$ *	G_{EQ20-1}	$EQSW = V_{REF2} + 0.5\text{ V}$ $f = 2\text{ MHz}$	–1.5	0	1.5	dB
EQ characteristics $\times 20-3$ *	G_{EQ20-3}	$EQSW = V_{REF2} + 0.5\text{ V}$ $f = 13\text{ MHz}$	–1.3	0.2	1.7	dB
AGC						
AGC max. gain	G_{MAGC}	$f = 500\text{ kHz}$, $V_{IN} = 20\text{ mV[p-p]}$	20.3	23.3	26.3	dB
AGC operating gain	G_{AGC}	$f = 500\text{ kHz}$, $V_{IN} = 500\text{ mV[p-p]}$	3.0	6.0	9.0	dB
AGC compression factor	ΔG_{AGC}	$f = 500\text{ kHz}$, $V_{IN} = 125\text{ mV[p-p]}$	–1.20	1.30	3.80	dB
AGC frequency characteristics	G_{FAGC}	$f = 30\text{ MHz}$, $V_{IN} = 20\text{ mV[p-p]}$	–4.5	–3.0	0	dB

Note) *: The values mentioned above are subject to change according to the state of a printed circuit board, a socket, etc.

■ Electrical Characteristics at $T_a = 25^\circ\text{C}$ (continued)

Parameter	Symbol	Conditions	Min	Typ	Max	Unit
NRF detection						
NRF det. detection level	V_{RDA1}	$f = 500 \text{ kHz}, V_{GC} = V_{REF2} - 0.75 \text{ V}$	73	105	137	mV[p-p]
NRF det. high-level output voltage	V_{RDAH}	$f = 500 \text{ kHz}, V_{GC} = V_{REF2} - 0.75 \text{ V}$	4.2	—	—	V
NRF det. low-level output voltage	V_{RDAL}	$f = 500 \text{ kHz}, V_{GC} = V_{REF2} - 0.75 \text{ V}$	—	—	0.8	V
NRF det. detection level ratio	B_{RDA}	$f = 500 \text{ kHz}, V_{GC} = V_{REF2}$	2.9	3.9	4.9	—
BDO						
CBDO detection current	I_{BDO}	$V_{CC1} = 5 \text{ V}, V_{CC2} = 3.3 \text{ V}$ $EQSW = V_{REF2} - 0.5 \text{ V}$	0.98	1.40	1.82	μA
CBDO detection current ratio	B_{IBD4}	$V_{CC1} = 5 \text{ V}, V_{CC2} = 3.3 \text{ V}$ $EQSW = V_{REF2}$	3.0	3.8	4.6	—
BDO high-level output voltage	V_{BDOH}	$V_{CC1} = 5 \text{ V}, V_{CC2} = 3.3 \text{ V}$ $f = 5 \text{ kHz}, \text{rectangular wave}$	4.2	—	—	V
BDO low-level output voltage	V_{BDOL}	$V_{CC1} = 5 \text{ V}, V_{CC2} = 3.3 \text{ V}$ $f = 5 \text{ kHz}, \text{rectangular wave}$	—	—	0.8	V
OFTR						
COFTR detection current	I_{OFTR}	$V_{CC1} = 5 \text{ V}, V_{CC2} = 3.3 \text{ V}$ $EQSW = V_{REF2} - 0.5 \text{ V}$	0.98	1.40	1.82	μA
COFTR detection current ratio	B_{IOFTR4}	$V_{CC1} = 5 \text{ V}, V_{CC2} = 3.3 \text{ V}$ $EQSW = V_{REF2}$	3.0	3.8	4.6	—
OFTR high-level output voltage	V_{OFTRH}	$V_{CC1} = 5 \text{ V}, V_{CC2} = 3.3 \text{ V}$ $f = 5 \text{ kHz}, \text{rectangular wave}$	4.2	—	—	V
OFTR low-level output voltage	V_{OFTRL}	$V_{CC1} = 5 \text{ V}, V_{CC2} = 3.3 \text{ V}$ $f = 5 \text{ kHz}, \text{rectangular wave}$	—	—	0.8	V
Masking operating voltage 1	V_{MASK1}	$f = 40 \text{ kHz}, V_{IN} = 100 \text{ mV[p-p]}$	—	—	0.35	V
Masking operating voltage 2	V_{MASK2}	$f = 40 \text{ kHz}, V_{IN} = 100 \text{ mV[p-p]}$	0.65	—	—	V
3TENV						
CEA to ENV transfer characteristics	$G_{CEA-ENV}$	$V_{CC1} = 5 \text{ V}, V_{CC2} = 3.3 \text{ V}$	20.0	23.0	26.0	dB
CEA input impedance	Z_{CEA}	$V_{CC1} = 5 \text{ V}, V_{CC2} = 3.3 \text{ V}$	6.8	8.8	10.8	$\text{k}\Omega$
ENV amp. output impedance	Z_{ENV}	$V_{CC1} = 5 \text{ V}, V_{CC2} = 3.3 \text{ V}$	6.4	8.4	10.4	$\text{k}\Omega$
ENV amp. offset voltage	V_{ENVOF}	$V_{CC1} = 5 \text{ V}, V_{CC2} = 3.3 \text{ V}$	-100	0	100	mV
ENV amp. operation	V_{ENV}	$V_{CC1} = 5 \text{ V}, V_{CC2} = 3.3 \text{ V}$ $f = 800 \text{ kHz}, \text{AM modulation}$	270	540	810	mV[p-p]
LD APC						
LD operating reference voltage	V_{LD}	$V_{CC1} = 5 \text{ V}, V_{CC2} = 3.3 \text{ V}$	135	170	205	mV
LDON operating voltage	V_{LDON}	$V_{CC1} = 5 \text{ V}, V_{CC2} = 3.3 \text{ V}$	—	—	-0.35	V

■ Application Circuit Example

