

IEEE1394 1-CHIP OHCI HOST CONTROLLER

The μPD72870A is the LSI which integrated OHCI-Link and PHY function into a single chip.

The μPD72870A complies with the P1394a draft 2.0 specifications and the OpenHCI IEEE1394 1.0, and works up to 400 Mbps.

It makes design so compact for PC and PC card application.

FEATURES

- Compliant with Link Layer Services as defined in 1394 Open Host Controller Interface specification release 1.0
- Compliant with Physical Layer Services as defined in P1394a draft 2.0 (Data Rate 100/200/400 Mbps)
- Numbers of supported port (1, 2, 3 ports) are selectable
- Compliant with protocol enhancement as defined in P1394a draft 2.0
- Modular 32-bit host interface compliant to PCI Specification release 2.1
- Support PCI-Bus Power Management Interface Specification release 1.0
- Modular 32-bit host interface compliant to Card Bus Specification
- Cycle Master and Isochronous Resource Manager capable
- Built-in FIFOs for isochronous transmit (1024 bytes), asynchronous transmit (1024 bytes), and receive (2048 bytes)
- 32-bit CRC generation and checking for receive/transmit packets
- 4 isochronous transmit DMAs and 4 isochronous receive DMAs supported
- 32-bit DMA channels for physical memory read/write
- Clock generation by 24.576 MHz X'tal
- Internal control and operational registers direct-mapped to PCI configuration space
- 2-wire Serial EEPROM™ interface supported
- Separate power supply Link and PHY
- Programmable latency timer from serial EEPROM in Cardbus mode (CARD_ON = 1)

ORDERING INFORMATION

Part number	Package
μPD72870AGM-8ED	160-pin plastic LQFP (Fine pitch) (24 x 24)
μPD72870AF1-FA2	192-pin plastic FBGA (14 x 14)

The information in this document is subject to change without notice. Before using this document, please confirm that this is the latest version.
Not all devices/types available in every country. Please check with local NEC representative for availability and additional information.

Firewarden™ ROADMAP

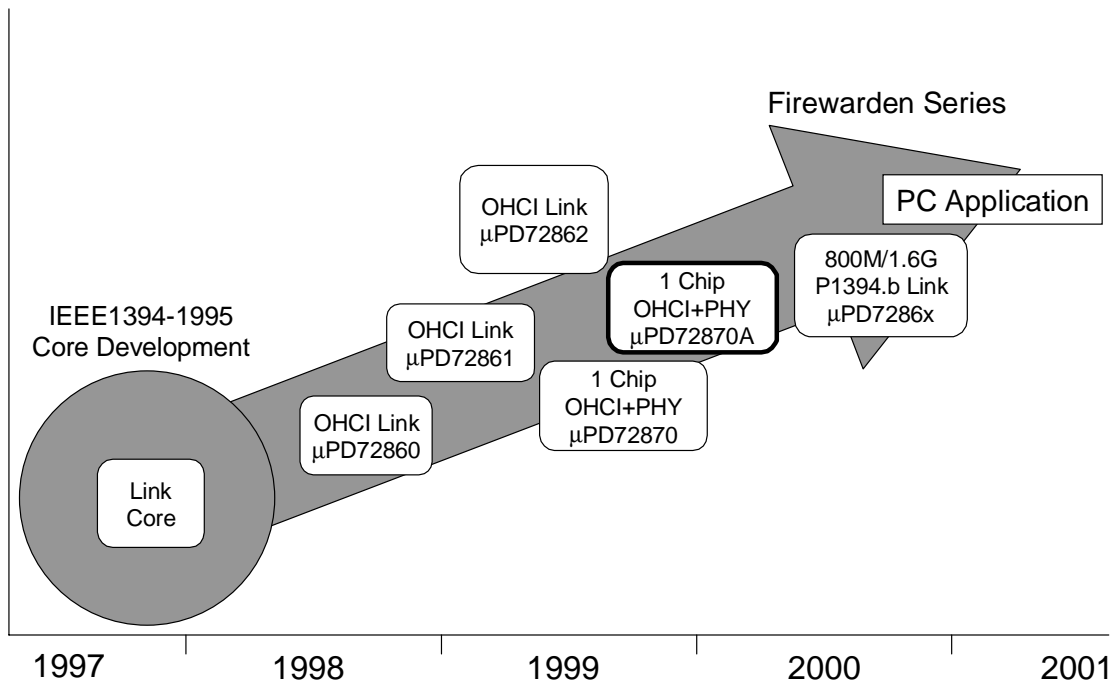

BLOCK DIAGRAMS

Top Block Diagram

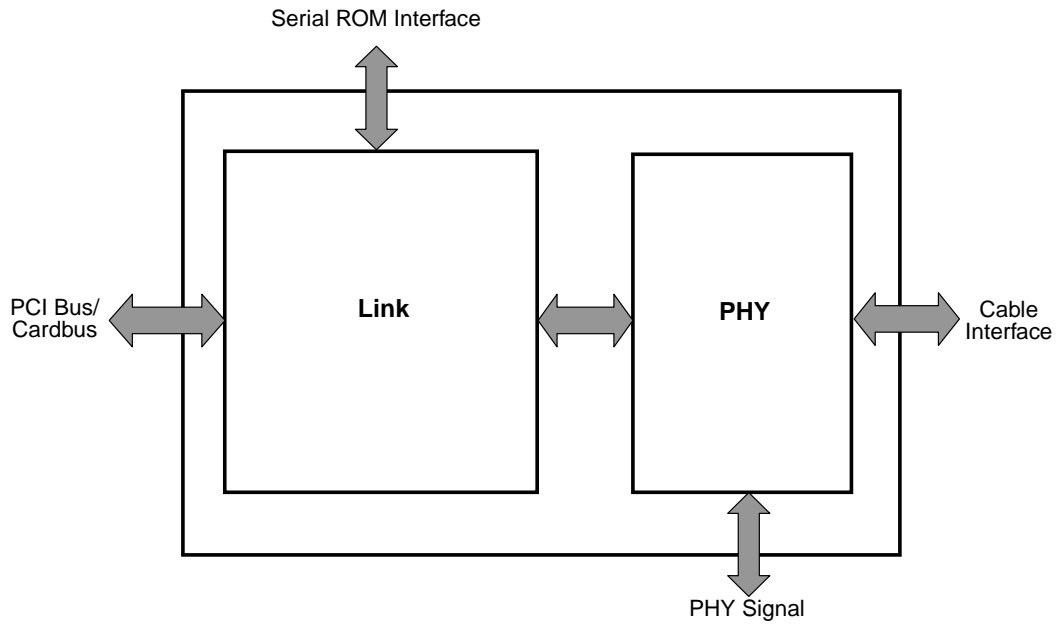

PHY Block Diagram

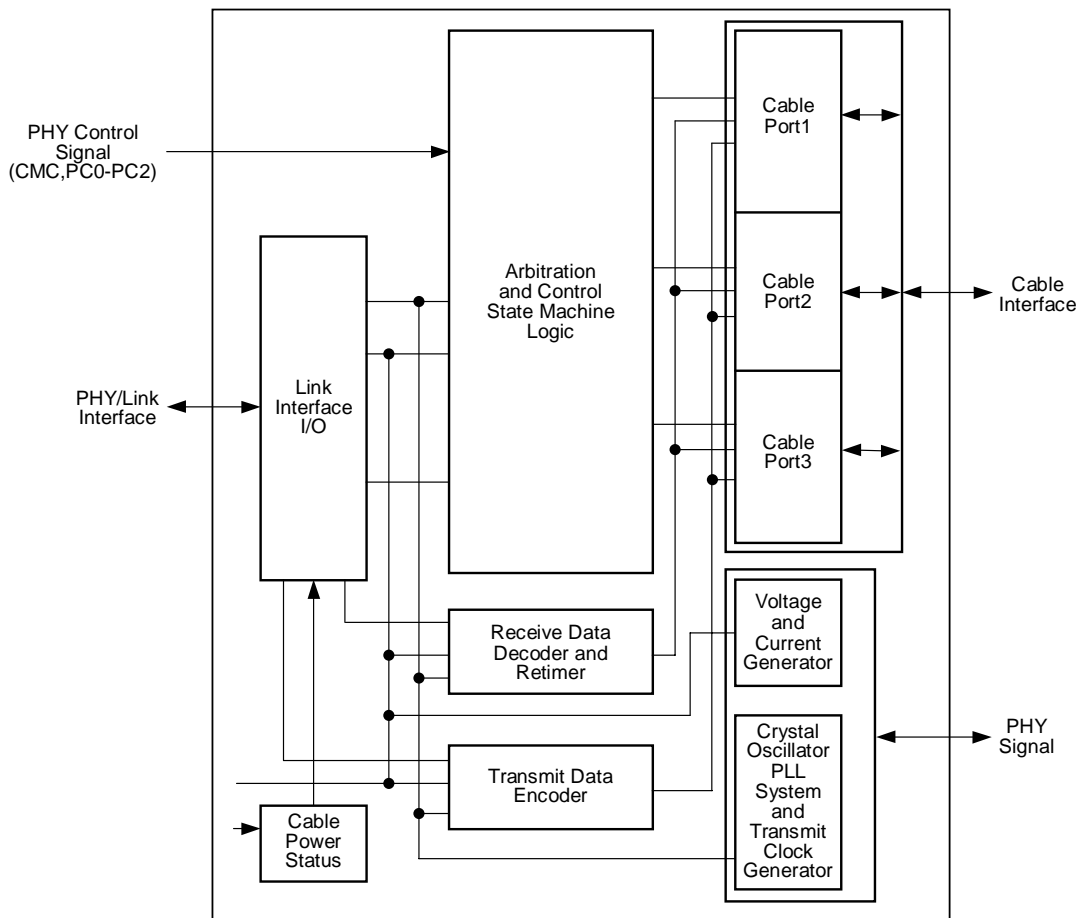

Remark Cable Port:

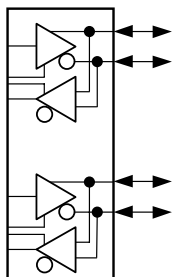

Link Block Diagram

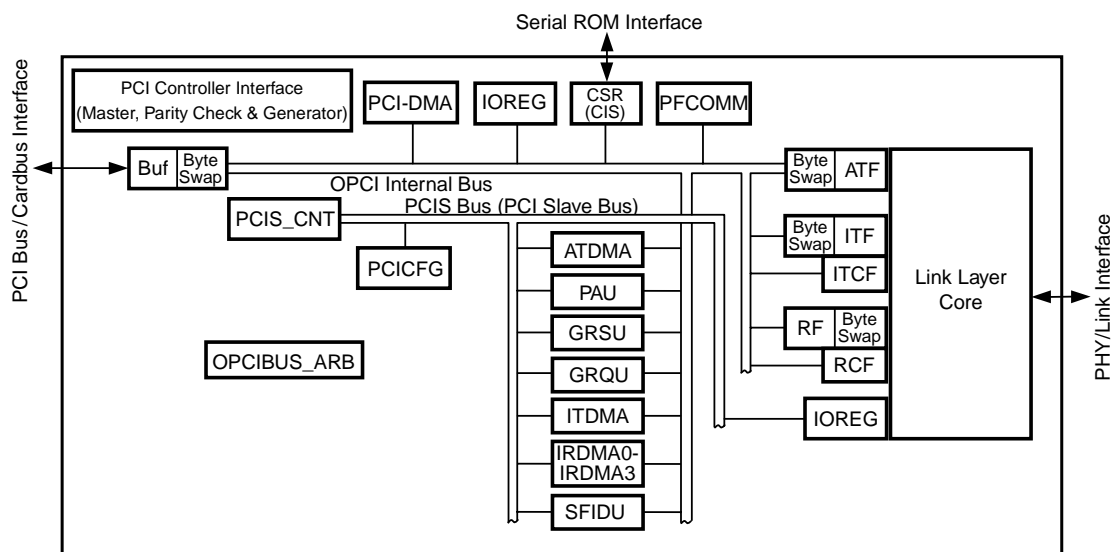

- ATDMA : Asynchronous Transmit DMA
- ATF : Asynchronous Transmit FIFO
- CIS : CIS Register
- CSR : Control and Status Registers
- IOREG : IO Registers
- IRDMA : Isochronous Receive DMA
- ITCF : Isochronous Transmit Control FIFO
- ITDMA : Isochronous Transmit DMA
- ITF : Isochronous Transmit FIFO
- OPCIBUS_ARB : OPCI Internal Bus Arbitration
- PAU : Physical Response and Request Unit
- PCICFG : PCI Configuration Registers
- PCIS_CNT : PHY Control Isochronous Control
- PFCOMM : Pre Fetch Command FIFO
- RCF : Receive Control FIFO
- RF : Receive FIFO
- SFIDU : Self-ID DMA

PIN CONFIGURATION

- 160-pin plastic LQFP (Fine pitch) (24 x 24)

μPD72870AGM-8ED

Top View

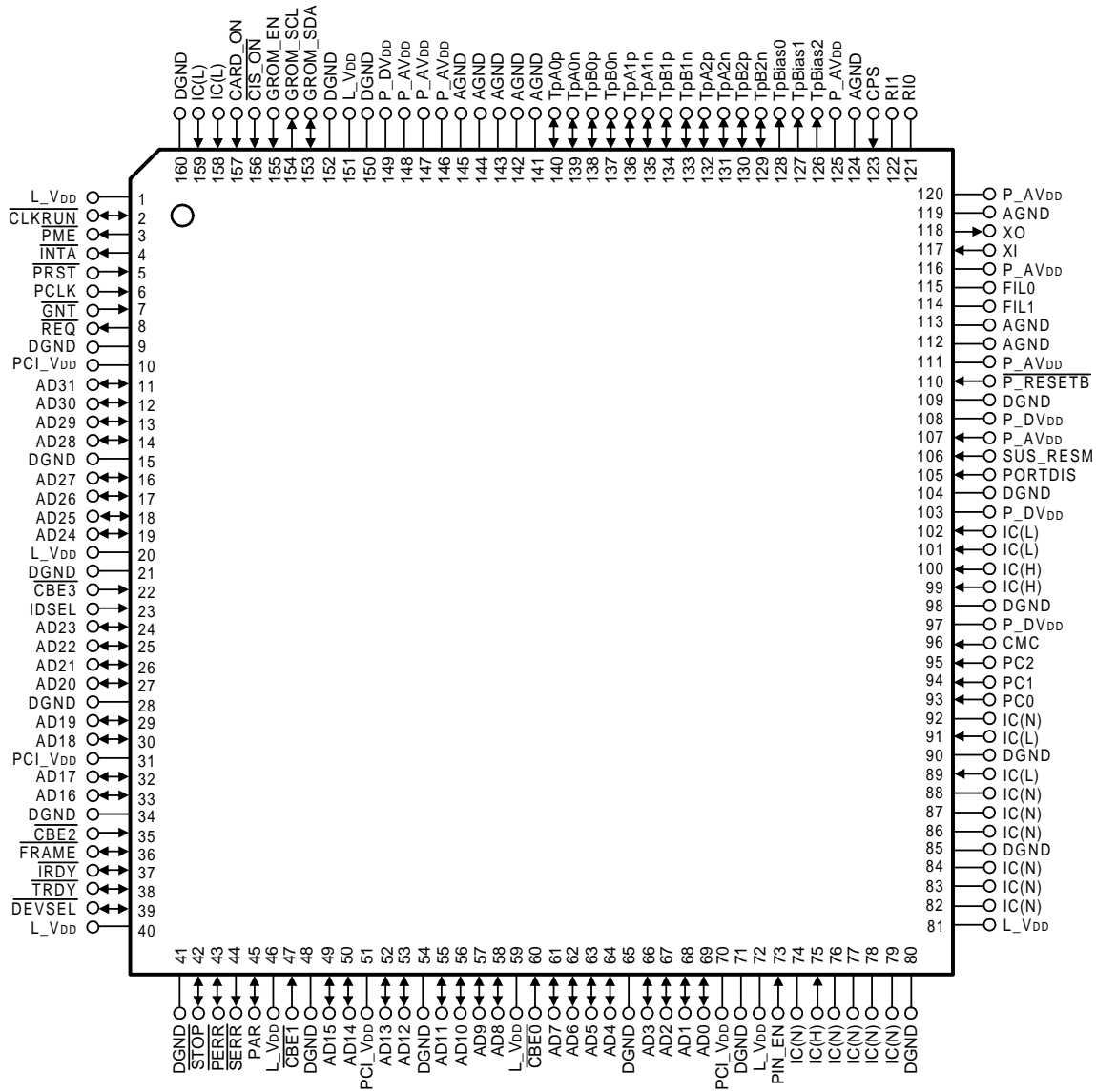

• 192-pin plastic FBGA (14 x 14)

μPD72870AF1-FA2

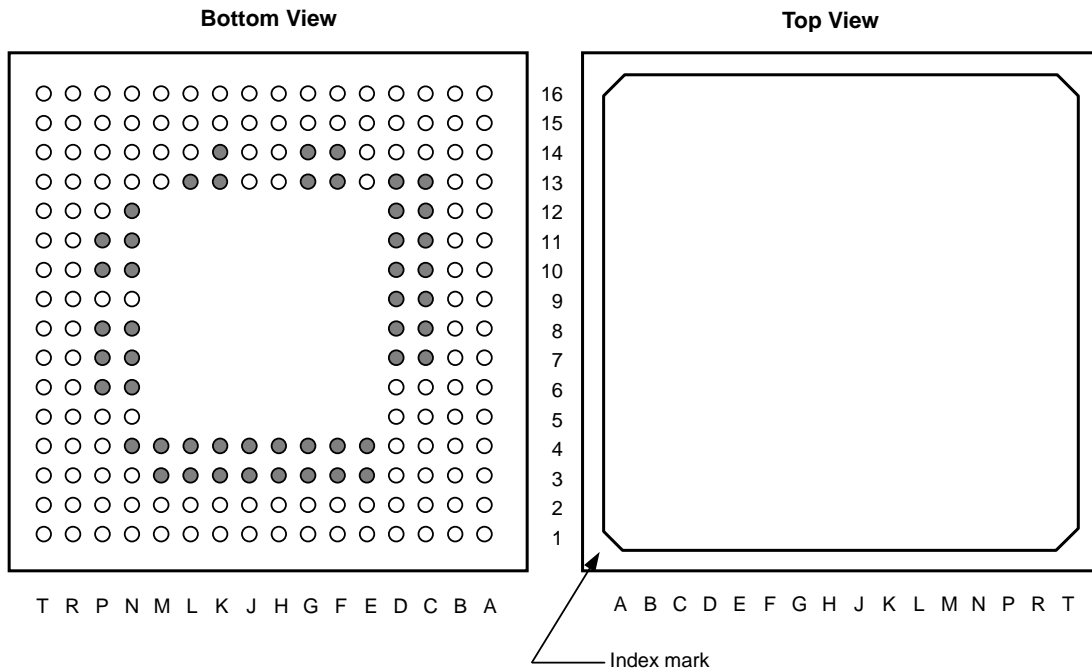

Remark ● : Pin connected on the FBGA board.

Phase-out/Discontinued

μPD72870AF1-FA2

Top View

	A	B	C	D	E	F	G	H	J	K	L	M	N	P	R	T
16	RI0	RI1	AGND	XO	FIL0	P_RESETB	P_AV _{DD}	PORTDIS	IC(L)	CMC	PC1	IC(L)	IC(N)	IC(N)	L_V _{DD}	DGND
15	CPS	AGND	P_AV _{DD}	XI	FIL1	P_AV _{DD}	SUS_RESM	DGND	IC(H)	PC2	PC0	DGND	IC(N)	IC(N)	IC(N)	IC(N)
14	TpBias2	TpBias1	TpBias0	P_AV _{DD}	AGND	DGND	P_DV _{DD}	P_DV _{DD}	IC(H)	P_DV _{DD}	IC(N)	IC(L)	DGND	IC(N)	IC(N)	IC(N)
13	TpB2n	TpB2p	AGND	P_AV _{DD}	AGND	DGND	P_DV _{DD}	IC(L)	DGND	P_DV _{DD}	P_DV _{DD}	IC(N)	L_V _{DD}	PIN_EN	IC(N)	IC(H)
12	TpA2n	TpA2p	AGND	P_AV _{DD}									PCL_V _{DD}	DGND	AD1	AD0
11	TpB1n	TpB1p	AGND	P_AV _{DD}									PCL_V _{DD}	DGND	AD3	AD2
10	TpA1n	TpA1p	AGND	AGND									L_V _{DD}	DGND	AD5	AD4
9	TpB0n	TpB0p	AGND	AGND									L_V _{DD}	CBE0	AD7	AD6
8	TpA0n	TpA0p	AGND	AGND									DGND	DGND	AD9	AD8
7	AGND	AGND	AGND	AGND									DGND	DGND	AD11	AD10
6	AGND	P_AV _{DD}	P_AV _{DD}	P_AV _{DD}	PCL_V _{DD}	PCL_V _{DD}	AD13	AD12								
5	P_DV _{DD}	DGND	L_V _{DD}	DGND	L_V _{DD}	DGND	AD15	AD14								
4	GROM_SDA	GROM_SCL	GROM_EN	IC(L)	DGND	DGND	DGND	DGND	L_V _{DD}	L_V _{DD}	L_V _{DD}	DGND	DGND	DGND	PAR	CBE1
3	CIS_ON	CARD_ON	IC(L)	DGND	PCL_V _{DD}	PCL_V _{DD}	DGND	DGND	DGND	DGND	DGND	DGND	PCL_V _{DD}	L_V _{DD}	PERR	SERR
2	L_V _{DD}	PME	PRST	GNT	AD31	AD29	AD27	AD25	CBE3	AD23	AD21	AD19	AD17	CBE2	IRDY	STOP
1	CLKRUN	INTA	PCLK	REQ	AD30	AD28	AD26	AD24	IDSEL	AD22	AD20	AD18	AD16	FRAME	TRDY	DEVSEL

PIN NAME

AD0-AD31	: PCI Multiplexed Address and Data	$\overline{\text{PME}}$: PME Output
AGND	: Analog GND	PORTDIS	: Port Disable
CARD_ON	: PCI/Card Select	$\overline{\text{PRST}}$: Reset
$\overline{\text{CBE0-CBE3}}$: Command/Byte Enables	P_AVDD	: PHY Analog V _{DD}
$\overline{\text{CIS_ON}}$: CIS Register ON	P_DVDD	: PHY Digital V _{DD}
$\overline{\text{CLKRUN}}$: PCICLK Running	$\overline{\text{P_RESETB}}$: PHY Power on Reset Input
CMC	: Configuration Manager Capable	$\overline{\text{REQ}}$: Bus_master Request
CPS	: Cable Power Status Input	RI0	: Resistor0 for Reference Current Setting
$\overline{\text{DEVSEL}}$: Device Select	RI1	: Resistor1 for Reference Current Setting
DGND	: Digital GND	$\overline{\text{SERR}}$: System Error
FIL0	: APLL Filter GND	$\overline{\text{STOP}}$: PCI Stop
FIL1	: APLL Filter Terminal	SUS_RESM	: Suspend/Resume Function Select
$\overline{\text{FRAME}}$: Cycle Frame	TpA0n	: Port-1 Twisted Pair A Negative Input/Output
$\overline{\text{GNT}}$: Bus_master Grant	TpA0p	: Port-1 Twisted Pair A Positive Input/Output
GROM_EN	: Serial EEPROM Enable	TpA1n	: Port-2 Twisted Pair A Negative Input/Output
GROM_SCL	: Serial EEPROM Clock Output	TpA1p	: Port-2 Twisted Pair A Positive Input/Output
GROM_SDA	: Serial EEPROM Data Input / Output	TpA2n	: Port-3 Twisted Pair A Negative Input/Output
IC(H)	: Internally Connected (High Clamped)	TpA2p	: Port-3 Twisted Pair A Positive Input/Output
IC(L)	: Internally Connected (Low Clamped)	TpB0n	: Port-1 Twisted Pair B Negative Input/Output
IC(N)	: Internally Connected (Open)	TpB0p	: Port-1 Twisted Pair B Positive Input/Output
IDSEL	: ID Select	TpB1n	: Port-2 Twisted Pair B Negative Input/Output
$\overline{\text{INTA}}$: Interrupt	TpB1p	: Port-2 Twisted Pair B Positive Input/Output
$\overline{\text{IRDY}}$: Initiator Ready	TpB2n	: Port-3 Twisted Pair B Negative Input/Output
L_VDD	: V _{DD} for Link Digital Core and Link I/Os	TpB2p	: Port-3 Twisted Pair B Positive Input/Output
PAR	: Parity	TpBias0	: Port-1 Twisted Pair Bias Voltage Output
PC0-PC2	: Power Class Input	TpBias1	: Port-2 Twisted Pair Bias Voltage Output
PCI_VDD	: V _{DD} for PCI I/Os	TpBias2	: Port-3 Twisted Pair Bias Voltage Output
PCLK	: PCI Clock	$\overline{\text{TRDY}}$: Target Ready
$\overline{\text{PERR}}$: Parity Error	XI	: X'tal XI
PIN_EN	: Pin Enable Input	XO	: X'tal XO

CONTENTS

- 1. PIN FUNCTIONS 12
 - 1.1 PCI/Cardbus Interface Signals: (52 pins)..... 12
 - 1.2 Cable Interface Signals: (15 pins) 13
 - 1.3 PHY Signals: (9 pins)..... 14
 - 1.4 PHY Control Signals: (5 pins)..... 14
 - 1.5 PCI/Cardbus Select Signals: (2 pins)..... 15
 - 1.6 Serial ROM Interface Signals: (3 pins)..... 15
 - 1.7 Miscellaneous Signal: (1 pin)..... 15
 - 1.8 IC: (21 pins) 16
 - 1.9 V_{DD} 16
 - 1.10 GND..... 16

- 2. PHY REGISTERS 17
 - 2.1 Complete Structure for PHY Registers..... 17
 - 2.2 Port Status Page (Page 000) 20
 - 2.3 Vendor ID Page (Page 001) 21

- 3. CONFIGURATION REGISTERS..... 22
 - 3.1 PCI Bus Mode Configuration Register (CARD_ON = Low) 22
 - 3.1.1 Offset_00 Vendor ID Register..... 23
 - 3.1.2 Offset_02 Device ID Register 23
 - 3.1.3 Offset_04 Command Register 23
 - 3.1.4 Offset_06 Status Register..... 24
 - 3.1.5 Offset_08 Revision ID Register..... 25
 - 3.1.6 Offset_09 Class Code Register 25
 - 3.1.7 Offset_0C Cache Line Size Register 25
 - 3.1.8 Offset_0D Latency Timer Register..... 25
 - 3.1.9 Offset_0E Header Type Register..... 25
 - 3.1.10 Offset_0F BIST Register..... 25
 - 3.1.11 Offset_10 Base Address 0 Register..... 26
 - 3.1.12 Offset_20 Subsystem Vendor ID Register 26
 - 3.1.13 Offset_22 Subsystem ID Register..... 26
 - 3.1.14 Offset_30 Expansion Rom Base Address Register 26
 - 3.1.15 Offset_34 Cap_Ptr Register..... 26
 - 3.1.16 Offset_3C Interrupt Line Register 27
 - 3.1.17 Offset_3D Interrupt Pin Register..... 27
 - 3.1.18 Offset_3E Min_Gnt Register 27
 - 3.1.19 Offset_3F Max_Lat Register 27
 - 3.1.20 Offset_40 PCI_OHCI_Control Register 27
 - 3.1.21 Offset_60 Cap_ID & Next_Item_Ptr Register 28
 - 3.1.22 Offset_62 Power Management Capabilities Register 28
 - 3.1.23 Offset_64 Power Management Control/Status Register 29
 - 3.2 CardBus Mode Configuration Register (CARD_ON = High) 30
 - 3.2.1 Offset_14/18 Base_Address_1/2 Register (Cardbus Status Registers) 31
 - 3.2.2 Offset_28 Cardbus CIS Pointer 32
 - 3.2.3 Offset_80 CIS Area..... 32

4. PHY FUNCTION 33

4.1 Cable Interface 33

4.1.1 Connections 33

4.1.2 Cable Interface Circuit 34

4.1.3 CPS..... 34

4.1.4 Unused Ports 34

4.2 Suspend/Resume..... 35

4.2.1 Suspend/Resume On Mode (SUS_RESM = 1)..... 35

4.2.2 Suspend/Resume Off Mode (SUS_RESM = 0)..... 35

4.3 PLL and Crystal Oscillation Circuit..... 36

4.3.1 Crystal Oscillation Circuit..... 36

4.3.2 PLL 36

4.4 PC0-PC2, CMC..... 36

4.5 P_RESETB 36

4.6 RI0, RI1 36

5. SERIAL ROM INTERFACE 37

5.1 Serial EEPROM Register 37

5.2 Serial EEPROM Register Description 37

5.3 Load Control..... 42

5.4 Programming Sequence Example..... 42

6. ELECTRICAL SPECIFICATIONS 44

7. APPLICATION CIRCUIT EXAMPLE..... 47

8. PACKAGE DRAWINGS 48

1. PIN FUNCTIONS

1.1 PCI/Cardbus Interface Signals: (52 pins)

(1/2)

Name	I/O	Pin No.		IoL	Volts(V)	Function	
		LQFP	FBGA				
PAR	I/O	45	R4	PCI/Cardbus	5/3.3	Parity is even parity across AD0-AD31 and $\overline{\text{CBE0-CBE3}}$. It is an input when AD0-AD31 is an input; it is an output when AD0-AD31 is an output.	Link ¹
AD0-AD31	I/O	11-14, 16-19, 24-27, 29,30,32, 33,49,50, 52,53, 55-58, 61-64, 66-69	E1,E2, F1,F2, G1,G2, H1,H2, K1,K2, L1,L2, M1,M2, N1,N2, R5-R12, T5-T12	PCI/Cardbus	5/3.3	PCI Multiplexed Address and Data	Link
$\overline{\text{CBE0-CBE3}}$	I	22,35,47, 60	J2,P2,P9, T4	-	5/3.3	Command/Byte Enables are multiplexed Bus Commands & Byte enables.	Link
$\overline{\text{FRAME}}$	I/O	36	P1	PCI/Cardbus	5/3.3	Frame is asserted by the initiator to indicate the cycle beginning and is kept asserted during the burst cycle. If Cardbus mode (CARD_ON = 1), this pin should be pulled up to V _{DD} .	Link
$\overline{\text{TRDY}}$	I/O	38	R1	PCI/Cardbus	5/3.3	Target Ready indicates that the current data phase of the transaction is ready to be completed.	Link
$\overline{\text{IRDY}}$	I/O	37	R2	PCI/Cardbus	5/3.3	Initiator Ready indicates that the current bus master is ready to complete the current data phase. During a write, its assertion indicates that the initiator is driving valid data onto the data bus. During a read, its assertion indicates that the initiator is ready to accept data from the currently-addressed target.	Link
$\overline{\text{REQ}}$	O	8	D1	PCI/Cardbus	5/3.3	Bus_master Request indicates to the bus arbiter that this device wants to become a bus master.	Link
$\overline{\text{GNT}}$	I	7	D2	-	5/3.3	Bus_master Grant indicates to this device that access to the bus has been granted.	Link
IDSEL	I	23	J1	-	5/3.3	Initialization Device Select is used as chip select for configuration read/write transaction during the phase of device initialization. If Cardbus mode (CARD_ON = 1), this pin should be pulled up to V _{DD} .	Link

(2/2)

Name	I/O	Pin No.		IoL	Volts(V)	Function	
		LQFP	FBGA				
DEVSEL	I/O	39	T1	PCI/Cardbus	5/3.3	Device Select when actively driven, indicates that the driving device has decoded its address as the target of the current access.	Link
STOP	I/O	42	T2	PCI/Cardbus	5/3.3	PCI Stop when actively driven, indicates that the target is requesting the current bus master to stop the transaction.	Link
PME	O	3	B2	PCI/Cardbus	5/3.3	PME Output for power management enable.	Link
CLKRUN	I/O	2	A1	PCI/Cardbus	5/3.3	PCICLK Running as input, to determine the status of PCLK; as output, to request starting or speeding up clock.	Link
INTA	O	4	B1	PCI/Cardbus	5/3.3	Interrupt the PCI interrupt request A.	Link
PERR	I/O	43	R3	PCI/Cardbus	5/3.3	Parity Error is used for reporting data parity errors during all PCI transactions, except a Special Cycle. It is an output when AD0-AD31 and PAR are both inputs. It is an input when AD0-AD31 and PAR are both outputs.	Link
SERR	O	44	T3	PCI/Cardbus	5/3.3	System Error is used for reporting address parity errors, data parity errors during the Special Cycle, or any other system error where the effect can be catastrophic. When reporting address parity errors, it is an output.	Link
PRST	I	5	C2	-	5/3.3	Reset PCI reset	Link
PCLK	I	6	C1	-	5/3.3	PCI Clock 33 MHz system bus clock.	Link

1.2 Cable Interface Signals: (15 pins)

(1/2)

Name	I/O	Pin No.		IoL	Volts(V)	Function	
		LQFP	FBGA				
TpA0p	I/O	140	B8	-	-	Port-1 Twisted Pair A Positive Input/Output ^{Note}	PHY Analog ²
TpA0n	I/O	139	A8	-	-	Port-1 Twisted Pair A Negative Input/Output ^{Note}	PHY Analog
TpB0p	I/O	138	B9	-	-	Port-1 Twisted Pair B Positive Input/Output ^{Note}	PHY Analog
TpB0n	I/O	137	A9	-	-	Port-1 Twisted Pair B Negative Input/Output ^{Note}	PHY Analog
TpA1p	I/O	136	B10	-	-	Port-2 Twisted Pair A Positive Input/Output ^{Note}	PHY Analog
TpA1n	I/O	135	A10	-	-	Port-2 Twisted Pair A Negative Input/Output ^{Note}	PHY Analog
TpB1p	I/O	134	B11	-	-	Port-2 Twisted Pair B Positive Input/Output ^{Note}	PHY Analog
TpB1n	I/O	133	A11	-	-	Port-2 Twisted Pair B Negative Input/Output ^{Note}	PHY Analog
TpA2p	I/O	132	B12	-	-	Port-3 Twisted Pair A Positive Input/Output ^{Note}	PHY Analog
TpA2n	I/O	131	A12	-	-	Port-3 Twisted Pair A Negative Input/Output ^{Note}	PHY Analog
TpB2p	I/O	130	B13	-	-	Port-3 Twisted Pair B Positive Input/Output ^{Note}	PHY Analog
TpB2n	I/O	129	A13	-	-	Port-3 Twisted Pair B Negative Input/Output ^{Note}	PHY Analog

Note If unused port, please refer to 4.1.4 **Unused Ports**.

(2/2)

Name	I/O	Pin No.		IoL	Volts(V)	Function	
		LQFP	FBGA				
PORTDIS	I	105	H16			Port Disable SUS_RESM = 1 This selected state will be loaded to Disabled bit which allocated PHY register Port Status Page. 1:Disable At this time, all ports will be disabled. SUS_RESM = 0 PORTDIS has no effect.	PHY Digital ³
SUS_RESM	I	106	G15			Suspend/Resume Function Select 1 : Suspend/Resume On (P1394a draft 2.0 compliant) 0 : Suspend/Resume Off (P1394a draft 1.3 compliant)	PHY Digital
CPS	I	123	A15	-	-	Cable Power Status Input ^{Note}	PHY Digital

Note Please refer to 4.1.3 CPS.

1.3 PHY Signals: (9 pins)

Name	I/O	Pin No.		IoL	Volts(V)	Function	
		LQFP	FBGA				
TpBias0	O	128	C14	-	-	Port-1 Twisted Pair Bias Voltage Output ^{Note 1}	PHY Analog
TpBias1	O	127	B14	-	-	Port-2 Twisted Pair Bias Voltage Output ^{Note 1}	PHY Analog
TpBias2	O	126	A14	-	-	Port-3 Twisted Pair Bias Voltage Output ^{Note 1}	PHY Analog
RI0	-	121	A16	-	-	Resistor0 for Reference Current Setting ^{Note 2}	PHY Analog
RI1	-	122	B16	-	-	Resistor1 for Reference Current Setting ^{Note 2}	PHY Analog
FIL1	-	114	E15	-	-	APLL Filter Terminal (No need to assemble)	PHY Analog
FIL0	-	115	E16	-	-	APLL Filter GND (No need to assemble)	PHY Analog
XI	I	117	D15	-	-	X'tal XI	PHY Analog
XO	O	118	D16	-	-	X'tal XO	PHY Analog

Notes 1. If unused port, please refer to 4.1.4 Unused Ports.

2. Please refer to 4.6 RI0, RI1.

1.4 PHY Control Signals: (5 pins)

Name	I/O	Pin No.		IoL	Volts(V)	Function	
		LQFP	FBGA				
PC0-PC2	I	93-95	K15,L15, L16	-	3.3	Power Class Input ^{Note 1}	PHY Digital
CMC	I	96	K16	-	3.3	Configuration Manager Capable ^{Note 1}	PHY Digital
P_RESETB	I	110	F16			PHY Power on Reset Input ^{Note 2}	PHY Digital

Notes 1. Please refer to 4.4 PC0-PC2, CMC.

2. Please refer to 4.5 P_RESETB.

1.5 PCI/Cardbus Select Signals: (2 pins)

Name	I/O	Pin No.		IoL	Volts(V)	Function	Link																
		LQFP	FBGA																				
CARD_ON	I	157	B3	-	3.3	PCI/Card Select (1:Cardbus, 0:PCI bus)	Link																
CIS_ON	I	156	A3	-	3.3	CIS Register ON <table border="1" style="width:100%; border-collapse: collapse;"> <thead> <tr> <th>CARD_ON</th> <th>CIS_ON</th> <th>CIS</th> <th>PME</th> </tr> </thead> <tbody> <tr> <td>0</td> <td>1</td> <td>Off</td> <td>PME</td> </tr> <tr> <td>0</td> <td>0</td> <td>On</td> <td>CSTSCHG</td> </tr> <tr> <td>1</td> <td>X</td> <td>On</td> <td>CSTSCHG</td> </tr> </tbody> </table>	CARD_ON	CIS_ON	CIS	PME	0	1	Off	PME	0	0	On	CSTSCHG	1	X	On	CSTSCHG	Link
CARD_ON	CIS_ON	CIS	PME																				
0	1	Off	PME																				
0	0	On	CSTSCHG																				
1	X	On	CSTSCHG																				

1.6 Serial ROM Interface Signals: (3 pins)

Name	I/O	Pin No.		IoL	Volts(V)	Function	Link
		LQFP	FBGA				
GROM_SDA	I/O	153	A4	6 mA	3.3	Serial EEPROM Data Input / Output	Link
GROM_SCL	O	154	B4	6 mA	3.3	Serial EEPROM Clock Output	Link
GROM_EN	I	155	C4	-	3.3	Serial EEPROM Enable (1: GUID Load enabled, 0: GUID Load disabled)	Link

1.7 Miscellaneous Signal: (1 pin)

Name	I/O	Pin No.		IoL	Volts(V)	Function	Link
		LQFP	FBGA				
PIN_EN	I	73	P13	-	5/3.3	Pin Enable Input (High clamped)	Link

1.8 IC: (21 pins)

Name	I/O	Pin No.		IoL	Volts(V)	Function	Link
		LQFP	FBGA				
IC(H)	I	75	T13	-	-	Internally Connected (High clamped)	Link
	I	99,100	J14,J15	-	-	Internally Connected (High clamped)	PHY Digital
IC(L)	I	89,158,159	C3,D4,M14	-	-	Internally Connected (Low clamped)	Link
	I	91,101,102	H13,J16,M16	-	-	Internally Connected (Low clamped)	PHY Digital
IC(N)	-	74,76-79, 82-84,86-88,92	L14,M13,N15,N16, P14-P16,R13-R15, T14,T15	-	-	Internally Connected (Open)	-

1.9 V_{DD}

Name	I/O	Pin No.		IoL	Volts(V)	Function	
		LQFP	FBGA				
PCI_V _{DD}	-	10,31,51,70	E3,F3,N3,N6, N11,N12,P6	-	5/3.3	V _{DD} for PCI I/Os	Link
L_V _{DD}	-	1,20,40,46,59,72,81, 151	A2,C5,J4,K4,L4,N5, N9,N10,N13,P3,R16	-	3.3	V _{DD} for Link digital Core and Link I/Os	Link
P_DV _{DD}	-	97,103,107,108,149	A5,G13,G14,G16, H14,K13,K14,L13	-	3.3	PHY digital V _{DD}	PHY Digital
P_AV _{DD}	-	111	F15	-	3.3	PHY PLL V _{DD}	PHY Analog
	-	116	D14	-	3.3	PHY PLL, OSC V _{DD}	PHY Analog
	-	120,125	C15,D11-D13	-	3.3	PHY Bias V _{DD}	PHY Analog
	-	146-148	B6,C6,D6	-	3.3	PHY Port V _{DD}	PHY Analog

1.10 GND

Name	I/O	Pin No.		IoL	Volts(V)	Function	
		LQFP	FBGA				
DGND	-	9,15,21,28,34,41,48, 54,65,71,80,85,90,98, 104,109,150,152,160	B5,D3,D5,E4,F4,F13, F14,G3,G4,H3,H4, H15,J3,J13,K3,L3, M3,M4,M15,N4,N7, N8,N14,P4,P5,P7,P8, P10-P12,T16	-	-	Digital GND	
AGND	-	112	E13	-	-	PHY PLL GND	
	-	113	E14	-	-	PHY PLL, OSC GND	
	-	119,124	B15,C16	-	-	PHY Bias GND	
	-	141	A7	-	-	PHY Common GND	
	-	142	B7	-	-	PHY Speed Signal GND	
	-	143,144,145	A6,C7-C13,D7-D10	-	-	PHY Port GND	

[Caution]

- *1: If the Link pin is pulled up, it should be connected to L_V_{DD}.
- *2: If the PHY Digital pin is pulled up, it should be connected to P_DV_{DD}.
- *3: If the PHY Analog pin is pulled up, it should be connected to P_AV_{DD}.

2. PHY REGISTERS

2.1 Complete Structure for PHY Registers

Figure 2-1. Complete Structure of PHY Registers

	0	1	2	3	4	5	6	7
0000	Physical_ID						R	PS
0001	RHB	IBR	Gap_count					
0010	Extended (7)			Reserved	Total_ports			
0011	Max_speed			Reserved	Delay			
0100	Link_active	Contender	Jitter			Pwr_class		
0101	Resume_int	ISBR	Loop	Pwr_fail	Timeout	Port_event	Enab_accel	Enab_multi
0110	Reserved							
0111	Page_select			Reserved	Port_select			
1000	Register0 (page_select)							
1001	Register1 (page_select)							
1010	Register2 (page_select)							
1011	Register3 (page_select)							
1100	Register4 (page_select)							
1101	Register5 (page_select)							
1110	Register6 (page_select)							
1111	Register7 (page_select)							

Table 2-1. Bit Field Description (1/3)

Field	Size	R/W	Reset value	Description
Physical_ID	6	R	000000	Physical_ID value selected from Self_ID period.
R	1	R	0	If this bit is 1, the node is root. 1: Root 0: Not root
PS	1	R		Cable power status. 1: Cable power on 0: Cable power off
RHB	1	R/W	0	Root Hold -off bit. If 1, becomes root at the bus reset.
IBR	1	R/W	0	Initiate bus reset. Setting to 1 begins a long bus reset. Long bus reset signal duration: 166 μs. Returns to 0 at the beginning of bus reset.
Gap_count	6	R/W	111111	Gap count value. It is updated by the changes of transmitting and receiving the PHY configuration packet Tx/Rx. The value is maintained after first bus reset. After the second bus reset it returns to reset value.

Table 2-1. Bit Field Description (2/3)

Field	Size	R/W	Reset value	Description
Extended	3	R	111	Shows the extended register map.
Total_ports	4	R	0011	Supported port number. 0011: 3 ports
Max_speed	3	R	010	Indicate the maximum speed that this node supports. 010: 98.304, 196.608 and 393.216 Mbps
Delay	4	R	0010	Indicate worst case repeating delay time. $144 + (2 \times 20) = 184$ ns
Link_active	1	R/W	1	Link active. 1: Enable 0: Disable The logical AND status of this bit and LPS. State will be referred to "L bit" of Self-ID Packet#0. The LPS is a PHY/Link interface signal and is defined in P1394a draft 2.0. It is an internal signal in the μPD72870A.
Contender	1	R/W	See Description	Contender. "1" indicate this node support bus manager function. This bit will be referred to "C bit" of Self-ID Packet#0. The reset data is depending on CMC pin setting. CMC pin condition 1: Pull up (Contender) 0: Pull down (Non Contender)
Jitter	3	R	010	The difference of repeating time (Max.-Min.). $(2+1) \times 20 = 60$ ns
Pwr_class	3	R/W	See Description	Power class. Please refer to IEEE1394 -1995 [4.3.4.1]. This bit will be referred to Pwr field of Self-ID Packet#0. The reset data will be determined by PC0-PC2 Pin status.
Resume_int	1	R/W	0	Resume interrupt enable. When set to 1, if any one port does resume, the Port_event bit becomes 1.
ISBR	1	R/W	0	Initiate short (arbitrated) bus reset. Setting to 1 acquires the bus and begins short bus reset. Short bus reset signal output : 1.3 μs Returns to 0 at the beginning of the bus reset.
Loop	1	R/W	0	Loop detection output. 1: Detection Writing 1 to this bit clears it to 0. Writing 0 has no effect.
Pwr_fail	1	R/W	0	Power cable disconnect detect. It becomes 1 when there is a change from 1 to 0 in the CPS bit. Writing 1 to this bit clears it to 0. Writing 0 has no effect.
Timeout	1	R/W	0	Arbitration state machine time-out. Writing 1 to this bit clears it to 0. Writing 0 has no effect.

Table 2-1. Bit Field Description (3/3)

Field	Size	R/W	Reset value	Description
Port_event	1	R/W	0	Set to 1 when the Int_Enable bit in the register map of each port is 1 and there is a change in the ports connected, Bias, Disabled and Fault bits. Set to 1 when the Resume_int bit is 1 and any one port does resume. Writing 1 to this bit clears it to 0. Writing 0 has no effect.
Enab_accel	1	R/W	0	Enables arbitration acceleration. Ack-acceleration and Fly-by arbitration are enabled. 1: Enabled 0: Disabled If this bit changes while the bus request is pending, the operation is not guaranteed.
Enab_multi	1	R/W	0	Enable multi-speed packet concatenation. Setting this bit to 1 follows multi-speed transmission. When this bit is set to 0, the packet will be transmitted with the same speed as the first packet.
Page_select	3	R/W	000	Select page address between 1000 to 1111. 000: Port Status Page 001: Vendor Definition Page Others: Unused
Port_select	4	R/W	0000	Port Selection. Selecting 000 (Port Status Page) with the page selection selects the port. 0000: Port 0 0001: Port 1 0010: Port 2 Others: Unused
Reserved	-	R	000...	Reserved. Read as 0.

2.2 Port Status Page (Page 000)

Figure 2-2. Port Status Page

	0	1	2	3	4	5	6	7
1000	AStat		BStat		Child	Connected	Bias	Disabled
1001	Negotiated_speed			Int_enable	Fault	Reserved		
1010	Reserved							
1011	Reserved							
1100	Reserved							
1101	Reserved							
1110	Reserved							
1111	Reserved							

Table 2-2. Bit Field Description

Field	Size	R/W	Reset value	Description
AStat	2	R	XX	A port status value. 00:---, 10: "0" 01: "1", 11: "Z"
BStat	2	R	XX	B port status value. 00:---, 10: "0" 01: "1", 11: "Z"
Child	1	R		Child node status value. 1: Connected to child node 0: Connected to parent node
Connected	1	R	0	Connection status value. 1: Connected 0: Disconnected
Bias	1	R		Bias voltage status value. 1: Bias voltage 0: No bias voltage
Disabled	1	R/W	See Description	The reset value is set by the PORTDIS pin. 1: Disable
Negotiated_Speed	3	R		Shows the maximum data transfer rate of the node connected to this port. 000: 100 Mbps 001: 200 Mbps 010: 400 Mbps
Int_enable	1	R/W	0	The Port_event is set to 1 by a change to 1 of the Connected, Bias, Disable, and Fault bits.
Fault	1	R/W	0	Set to 1 if an error occurs during Suspend/Resume. Writing 1 to this bit clears it to 0. Writing 0 has no effect.
Reserved	-	R	000...	Reserved. Read as 0.

2.3 Vendor ID Page (Page 001)

Figure 2-3. Vendor ID Page

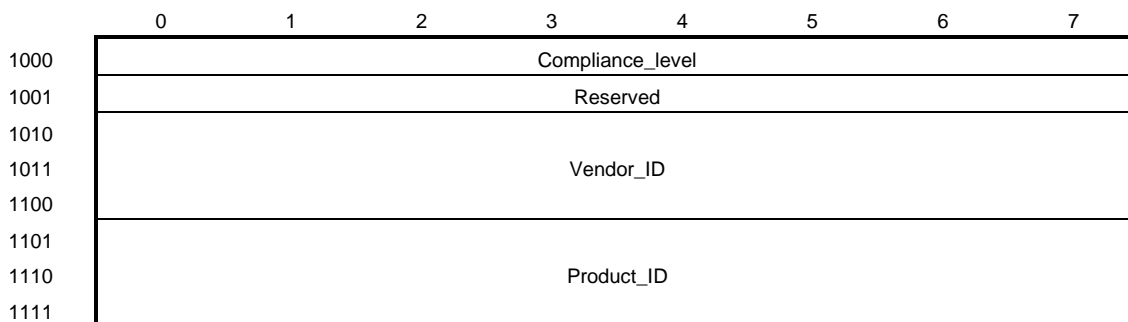

Table 2-3. Bit Field Description

Field	Size	R/W	Reset value	Description
Compliance_level	8	R	00000001	According to IEEE P1394a.
Vendor_ID	24	R	00004CH	Company ID Code value, NEC IEEE OUI.
Product_ID	24	R		Product code.
Reserved	-	R	000...	Reserved. Read as 0.

3. CONFIGURATION REGISTERS

3.1 PCI Bus Mode Configuration Register (CARD_ON = Low)

31	24 23	16 15	08 07	00	
Device ID		Vendor ID			00H
Status		Command			04H
Class Code			Revision ID		08H
BIST	Header Type	Latency Timer	Cache Line Size		0CH
Base Address 0					10H
Base Address 1					14H
Base Address 2					18H
Base Address 3					1CH
Base Address 4					20H
Base Address 5					24H
CardBus CIS Pointer					28H
Subsystem ID		Subsystem Vendor ID			2CH
Expansion Rom Base Address Register					30H
000000H			Cap_Ptr		34H
00000000H					38H
Max_Lat	Min_Gnt	Interrupt Pin	Interrupt Line		3CH
PCI_OHCI_Control					40H
00000000H					44H
00000000H					48H
00000000H					4CH
Diagnostic register0					50H
Diagnostic register1					54H
Diagnostic register2					58H
Diagnostic register3					5CH
Power Management Capabilities		Next_Item_Ptr	Cap_ID		60H
Data	PMCSR_BSE	Power Management Control/Status			64H
00000000H					68H
00000000H					6CH
00000000H					70H
User Area (GENERAL_RegisterB)					74H
User Area (GENERAL_RegisterC)					78H
User Area (GENERAL_RegisterD)					7CH
00000000H					80H FCH

3.1.1 Offset_00 Vendor ID Register

This register identifies the manufacturer of the μPD72870A. The ID is assigned by the PCI_SIG committee.

Bits	R/W	Description
15-0	R	Constant value of 1033H.

3.1.2 Offset_02 Device ID Register

This register identifies the type of the device for the μPD72870A. The ID is assigned by NEC Corporation.

Bits	R/W	Description
15-0	R	Constant value of 00CDH.

3.1.3 Offset_04 Command Register

The register provides control over the device's ability to generate and respond to PCI cycles.

Bits	R/W	Description
0	R	I/O enable Constant value of 0. The μPD72870A does not respond to PCI I/O accesses.
1	R/W	Memory enable Default value of 1. It defines if the μPD72870A responds to PCI memory accesses. This bit should be set to one upon power-up reset. 0: The μPD72870A does not respond to PCI memory cycles 1: The μPD72870A responds to PCI memory cycles
2	R/W	Master enable Default value of 1. It enables the μPD72870A as bus-master on the PCI-bus. 0: The μPD72870A cannot generate PCI accesses by being a bus-master 1: The μPD72870A is capable of acting as a bus-master
3	R	Special cycle monitor enable Constant value of 0. The special cycle monitor is always disabled.
4	R/W	Memory write and invalidate enable Default value of 0. It enables Memory Write and Invalidate Command generation. 0: Memory write must be used 1: The μPD72870A, when acts as PCI master, can generate the command
5	R	VGA color palette invalidate enable Constant value of 0. VGA color palette invalidate is always disabled.
6	R/W	Parity error response Default value of 0. It defines if the μPD72870A responds to PERR. 0: Ignore parity error 1: Respond to parity error
7	R	Stepping enable Constant value of 0. Stepping is always disabled.
8	R/W	System error enable Default value of 0. It defines if the μPD72870A responds to SERR. 0: Disable system error checking 1: Enable system error checking
9	R	Fast back-to-back enable Constant value of 0. Fast back-to-back transactions are only allowed to the same agent.
15-10	R	Reserved Constant value of 000000.

3.1.4 Offset_06 Status Register

This register tracks the status information of PCI-bus related events which are relevant to the μPD72870A. “Read” and “Write” are handled somewhat differently.

Bits	R/W	Description
3-0	R	Reserved Constant value of 0000.
4	R	New capabilities Constant value of 1. It indicates the existence of the Capabilities List.
6,5	R	Reserved Constant value of 00.
7	R	Fast back-to-back capable Constant value of 1. It indicates that the μPD72870A, as a target, cannot accept fast back-to-back transactions when the transactions are not to the same agent.
8	R/W	Signaled parity error Default value of 0. It indicates the occurrence of any “Data Parity”. 0: No parity detected (default) 1: Parity detected
10,9	R	DEVSEL timing Constant value of 01. These bits define the decode timing for DEVSEL. 0: Fast (1 cycle) 1: Medium (2 cycles) 2: Slow (3 cycles) 3: undefined
11	R/W	Signaled target abort Default value of 0. This bit is set by a target device whenever it terminates a transaction with “Target Abort”. 0: The μPD72870A did not terminate a transaction with Target Abort 1: The μPD72870A has terminated a transaction with Target Abort
12	R/W	Received target abort Default value of 0. This bit is set by a master device whenever its transaction is terminated with a “Target Abort”. 0: The μPD72870A has not received a Target Abort 1: The μPD72870A has received a Target Abort from a bus-master
13	R/W	Received master abort Default value of 0. This bit is set by a master device whenever its transaction is terminated with “Master Abort”. The μPD72870A asserts “Master Abort” when a transaction response exceeds the time allocated in the latency timer field. 0: Transaction was not terminated with a Master Abort 1: Transaction has been terminated with a Master Abort
14	R/W	Signaled system error Default value of 0. It indicates that the assertion of SERR by the μPD72870A. 0: System error was not signaled 1: System error was signaled
15	R/W	Received parity error Default value of 0. It indicates the occurrence of any PERR. 0: No parity error was detected 1: Parity error was detected

3.1.5 Offset_08 Revision ID Register

This register specifies a revision number assigned by NEC Corporation for the μPD72870A.

Bits	R/W	Description
7-0	R	Default value of 02H. It specifies the silicon revision. It will be incremented for subsequent silicon revisions.

3.1.6 Offset_09 Class Code Register

This register identifies the class code, sub-class code, and programming interface of the μPD72870A.

Bits	R/W	Description
7-0	R	Constant value of 10H. It specifies an IEEE1394 OpenHCI-compliant Host Controller.
15-8	R	Constant value of 00H. It specifies an "IEEE1394" type.
23-16	R	Constant value of 0CH. It specifies a "Serial Bus Controller".

3.1.7 Offset_0C Cache Line Size Register

This register specifies the system cache line size, which is PC-host system dependent, in units of 32-bit words. The following cache line sizes are supported: 2, 4, 8, 16, 32, 64, and 128. All other values will be recognized as 0, i.e. cache disabled.

Bits	R/W	Description
7-0	R/W	Default value of 00H.

3.1.8 Offset_0D Latency Timer Register

This register defines the maximum amount of time that the μPD72870A is permitted to retain ownership of the bus after it has acquired bus ownership and initiated a subsequent transaction.

Bits	R/W	Description
7-0	R/W	Default value of 00H. It specifies the number of PCI-bus clocks that the μPD72870A may hold the PCI bus as a bus-master.

3.1.9 Offset_0E Header Type Register

Bits	R/W	Description
7-0	R	Constant value of 00H. It specifies a single function device.

3.1.10 Offset_0F BIST Register

Bits	R/W	Description
7-0	R	Constant value of 00H. It specifies whether the device is capable of Built-in Self Test.

3.1.11 Offset_10 Base Address 0 Register

This register specifies the base memory address for accessing all the “Operation registers” (i.e. control, configuration, and status registers) of the μPD72870A, while the BIOS is expected to set this value during power-up reset.

Bits	R/W	Description
11-0	R	Constant value of 000H. These bits are “read-only”.
31-12	R/W	-

3.1.12 Offset_20 Subsystem Vendor ID Register

This register identifies the subsystem that contains the NEC’s μPD72870A function. While the ID is assigned by the PCI_SIG committee, the value should be loaded into the register from the external serial ROM after power-up reset. Access to this register through PCI-bus is prohibited.

Bits	R/W	Description
15-0	R	Default value of 1033H.

3.1.13 Offset_22 Subsystem ID Register

This register identifies the type of the subsystem that contains the NEC’s μPD72870A function. While the ID is assigned by the manufacturer, the value should be loaded into the register from the external serial EEPROM after power-up reset. Access to this register through PCI-bus is prohibited.

Bits	R/W	Description
15-0	R	Default value of 0063H.

3.1.14 Offset_30 Expansion Rom Base Address Register

This register is not supported by the current implementation of the μPD72870A.

Bits	R/W	Description
31-0	R	Reserved Constant value of 0.

3.1.15 Offset_34 Cap_Ptr Register

This register points to a linked list of additional capabilities specific to the μPD72870A, the NEC’s implementation of the 1394 OpenHCI specification.

Bits	R/W	Description
7-0	R	Constant value of 60H. The value represents an offset into the μPD72870A’s PCI Configuration Space for the location of the first item in the New Capabilities Linked List.

3.1.16 Offset_3C Interrupt Line Register

This register provides the interrupt line routing information specific to the μPD72870A, the NEC's implementation of the 1394 OpenHCI specification.

Bits	R/W	Description
7-0	R/W	Default value of 00H. It specifies which input of the host system interrupt controller the interrupt pin of the μPD72870A is connected to.

3.1.17 Offset_3D Interrupt Pin Register

This register provides the interrupt line routing information specific to the μPD72870A, the NEC's implementation of the 1394 OpenHCI specification.

Bits	R/W	Description
7-0	R	Constant value of 01H. It specifies PCI INTA is used for interrupting the host system.

3.1.18 Offset_3E Min_Gnt Register

This register specifies how long of a burst period the μPD72870A needs, assuming a clock rate of 33 MHz. Resolution is in units of ¼ μs. The value should be loaded into the register from the external serial EEPROM upon power-up reset, and access to this register through PCI-bus is prohibited.

Bits	R/W	Description
7-0	R	Default value of 00H. Its value contributes to the desired setting for Latency Timer value.

3.1.19 Offset_3F Max_Lat Register

This register specifies how often the μPD72870A needs to gain access to the PCI-bus, assuming a clock rate of 33 MHz. Resolution is in units of ¼ μs. The value should be loaded into the register from the external serial EEPROM after hardware reset, and access to this register through PCI-bus is prohibited.

Bits	R/W	Description
7-0	R	Default value of 00H. Its value contributes to the desired setting for Latency Timer value.

3.1.20 Offset_40 PCI_OHCI_Control Register

This register specifies the control bits that are IEEE1394 OpenHCI specific. Vendor options are not allowed in this register. It is reserved for OpenHCI use only.

Bits	R/W	Description
0	R/W	PCI global SWAP Default value of 0. When this bit is 1, all quadrates read from and written to the PCI Interface are byte swapped, thus a "PCI Global Swap". PCI addresses for expansion ROM and PCI Configuration registers, are, however, unaffected by this bit. This bit is not required for motherboard implementations.
31-1	R	Reserved Constant value of all 0.

3.1.21 Offset_60 Cap_ID & Next_Item_Ptr Register

The Cap_ID signals that this item in the Linked List is the registers defined for PCI Power Management, while the Next_Item_Ptr describes the location of the next item in the μPD72870A's Capability List.

Bits	R/W	Description
7-0	R	Cap_ID Constant value of 01H. The default value identified the Link List item as being the PCI Power Management registers, while the ID value is assigned by the PCI SIG.
15-8	R	Next_Item_Ptr Constant value of 00H. It indicated that there are no more items in the Link List.

3.1.22 Offset_62 Power Management Capabilities Register

This is a 16-bit read-only register that provides information on the power management capabilities of the μPD72870A.

Bits	R/W	Description
2-0	R	version Constant value of 001. The power management registers are implemented as defined in revision 1.0 of PCI Bus Power Management Interface Specification.
3	R	PME clock Constant value of 0.
4	R	Auxiliary power source Constant value of 0. The alternative power source is not supported.
5	R	DIS Constant value of 0.
8,6	R	Reserved Constant value of 000.
9	R	D1_support Constant value of 0. The μPD72870A does not support the D1 Power Management state.
10	R	D2_support Constant value of 1. The μPD72870A supports the D2 Power Management state.
15-11	R	PME_support Constant value of 01100.

3.1.23 Offset_64 Power Management Control/Status Register

This is a 16-bit read-only register that provides control status information of the μPD72870A.

Bits	R/W	Description
1,0	R/W	<p>PowerState Default value is undefined. This field is used both to determine the current power state of the μPD72870A and to set the μPD72870A into a new power state. As D1 is not supported in the current implementation of the μPD72870A, writing of '01' will be ignored.</p> <p>00: D0 (DMA contexts: ON, Link Layer: ON)</p> <p>01: Reserved (D1 state not supported)</p> <p>10: D2 (DMA contexts: OFF, Link Layer: OFF, LPS: OFF, PME will be asserted upon LinkON being active)</p> <p>11: D3 (DMA contexts: OFF, Link Layer: OFF, LPS: OFF, PME will be asserted upon LinkON being active, Power can be removed)</p> <p>The LPS is a PHY/Link interface signal and is defined in P1394a draft 2.0. It is an internal signal in the μPD72870A.</p>
7-2	R	Reserved Constant value of 000000.
8	R/W	PME_En Default value of 0. This field is used to enable the specific power management features of the μPD72870A.
12-9	R	Data_Select Constant value of 0000.
14,13	R	Data_Scale Constant value of 00.
15	R/W	PME_Status Default value is undefined. A write of '1' clears this bit, while a write of '0' is ignored.

3.2 CardBus Mode Configuration Register (CARD_ON = High)

31	24	23	16	15	08	07	00	
Device ID				Vendor ID				00H
Status				Command				04H
Class Code						Revision ID		08H
BIST		Header Type		Latency Timer		Cache Line Size		0CH
Base Address 0								10H
Base Address 1 (CardBus Status Reg) <i>Note</i>								14H
Base Address 2 (CardBus Status Reg) <i>Note</i>								18H
Base Address 3								1CH
Base Address 4								20H
Base Address 5								24H
CardBus CIS Pointer <i>Note</i>								28H
Subsystem ID				Subsystem Vendor ID				2CH
Expansion Rom Base Address Register								30H
000000H						Cap_Ptr		34H
00000000H								38H
Max_Lat		Min_Gnt		Interrupt Pin		Interrupt Line		3CH
PCI_OHCI_Control								40H
00000000H								44H
00000000H								48H
00000000H								4CH
Diagnostic register0								50H
Diagnostic register1								54H
Diagnostic register2								58H
Diagnostic register3								5CH
Power Management Capabilities				Next_Item_Ptr		Cap_ID		60H
Data		PMCSR_BSE		Power Management Control/Status				64H
00000000H								68H
00000000H								6CH
00000000H								70H
User Area (GENERAL_RegisterB)								74H
User Area (GENERAL_RegisterC)								78H
User Area (GENERAL_RegisterD)								7CH
CIS Area <i>Note</i>								80H FCH

Note Different from PCI Bus Mode Configuration Register.

3.2.1 Offset_14/18 Base_Address_1/2 Register (Cardbus Status Registers)

Bits	R/W	Description
7-0	R	Constant value of 00.
31-8	R/W	-

(1) Function Event Register (FER) (Base Address 1 (2)+ 0H)

Bits	R/W	Description
0	R	Write Protect (No Use). Read only as '0'
1	R	Ready Status (No Use). Read only as '0'
2	R	Battery Voltage Detect 2 (No Use). Read only as '0'
3	R	Battery Voltage Detect 1 (No Use). Read only as '0'
4	R/W	General Wakeup
14-5	R	Reserved. Read only as '0'
15	R/W	Interrupt
31-16	R	Reserved. Read only as '0'

(2) Function Event Mask Register (FEMR) (Base Address 1 (2)+ 4H)

Bits	R/W	Description
0	R	Write Protect (No Use). Read only as '0'
1	R	Ready Status (No Use). Read only as '0'
2	R	Battery Voltage Detect 2 (No Use). Read only as '0'
3	R	Battery Voltage Detect 1 (No Use). Read only as '0'
4	R/W	General Wakeup Mask
5	R	BAM. Read only as '0'
6	R	PWM. Read only as '0'
13-7	R	Reserved. Read only as '0'
14	R/W	Wakeup Mask
15	R/W	Interrupt
31-16	R	Reserved. Read only as '0'

(3) Function Reset Status Register (FRSR) (Base Address 1 (2)+ 8H)

Bits	R/W	Description
0	R	Write Protect (No Use). Read only as '0'
1	R	Ready Status (No Use). Read only as '0'
2	R	Battery Voltage Detect 2 (No Use). Read only as '0'
3	R	Battery Voltage Detect 1 (No Use). Read only as '0'
4	R/W	General Wakeup Mask
14-5	R	Reserved. Read only as '0'
15	R/W	Interrupt
31-16	R	Reserved. Read only as '0'

(4) Function Force Event Register (FFER) (Base Address 1 (2)+ CH)

Bits	R/W	Description
0	R	Write Protect (No Use). Read only as '0'
1	R	Ready Status (No Use). Read only as '0'
2	R	Battery Voltage Detect 2 (No Use). Read only as '0'
3	R	Battery Voltage Detect 1 (No Use). Read only as '0'
4	R/W	General Wakeup Mask
14-5	-	No Use
15	R/W	Interrupt
31-16	R	Reserved. Read only as '0'

3.2.2 Offset_28 Cardbus CIS Pointer

This register specifies start memory address of the Cardbus CIS Area.

Bits	R/W	Description
31-0	R	Starting Pointer of CIS Area. Constant value of 00000080H.

3.2.3 Offset_80 CIS Area

The μPD72870A supports external Serial ROM (AT24C02 compatible) interface.

CIS Area Register can be loaded from external Serial ROM in the CIS area when CARD_ON is 1.

CARD_ON	CIS_ON	Bus	CIS	Function
0	1	PCI	Off	PME
0	0	PCI	On	CSTSCHG
1	X	Cardbus	On	CSTSCHG

4. PHY FUNCTION

4.1 Cable Interface

4.1.1 Connections

Figure 4-1. Cable Interface

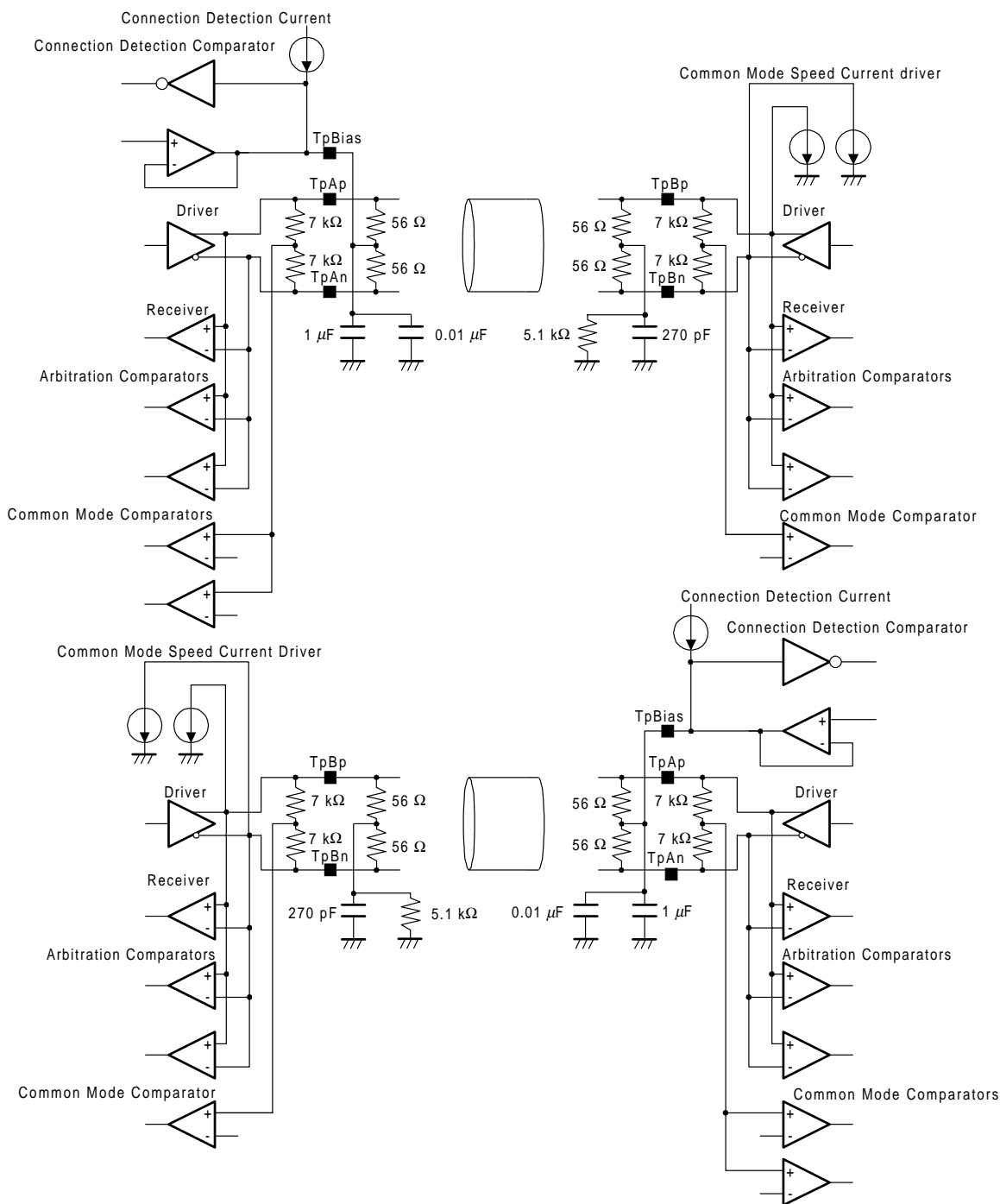

4.1.2 Cable Interface Circuit

Each port is configured with two twisted-pairs of TpA and TpB.

TpA and TpB are used to monitor the state of the Transmit/Receive line, control signals, data and cables.

During transmission to the IEEE1394 bus, the Data/Strobe signal received from the Link layer controller is encoded, converted from parallel to serial and transmitted.

While receiving from the IEEE1394 bus, the Data/Strobe signal from TpA, TpB is converted from serial to parallel after synchronization by SCLK ^{Note}, then transmitted to the Link layer controller in 2/4/8 bits according to the data rate of 100/200/400 Mbps.

The bus arbitration for TpA and TpB and the state of the line are monitored by the built-in comparator. The state of the 1394 bus is transmitted to the state machine in the LSI.

Note The SCLK is a PHY/Link interface signal and is defined in P1394a draft 2.0. It is an internal signal in the μ PD72870A.

4.1.3 CPS

An external resistance of 390 k Ω is connected in series to the power cable to monitor the power of the power cable. If the cable power falls under 7.5 V there is an indication to the Link layer that the power has failed.

4.1.4 Unused Ports

TpAp, TpAn : Not connected

TpBp, TpBn : AGND

TpBias : Connected to AGND using a 1.0 μ F load capacitor

No need to assemble the capacitor if using as Suspend/Resume On mode (SUS_RESM = 1).

4.2 Suspend/Resume

4.2.1 Suspend/Resume On Mode (SUS_RESM = 1)

There are two ways of transition from the active status to the suspended status.

One is when the receipt of a remote command packet that sets the initiate suspend command. After that, the PHY transmits a remote confirmation packet with the ok bit set, subsequently signals TX_SUSPEND to the connected peer PHY with the port which specified by the port field in the remote command packet, and then the PHY port transitions to the suspended state.

The other is when the receipt of a RX_SUSPEND or RX_DISABLE_NOTIFY signal. When the port observes RX_SUSPEND, it transmits TX_SUSPEND to the active ports.

The TX_SUSPEND transmitted propagates until it reaches a leaf node. The PHY port transitions to the suspended state. The propagation of the suspended domain may be blocked by a PHY compliant with IEEE Std 1394-1995, a disabled or a suspended port.

Any one of a number of reasons may cause a suspended port to attempt to resume normal operations:

- Bias is detected and there is no fault condition;
- A resume packet is received or transmitted by the PHY;
- A remote command packet that sets the resume port command is received; or
- Either port of a node without active ports detects bias.

4.2.2 Suspend/Resume Off Mode (SUS_RESM = 0)

- Remote command packet is ignored.
- Resume packet is ignored.
- Disabled, Int_enable and resume_int bits in PHY register are ignored.
- Responses to Remote access packet.
- Detects the connection of the port in TpBias.

4.3 PLL and Crystal Oscillation Circuit

4.3.1 Crystal Oscillation Circuit

To supply the clock of 24.576 MHz \pm 100 ppm, use an external capacitor of 10 pF and a crystal of 50 ppm.

4.3.2 PLL

The crystal oscillator multiplies the 24.576 MHz frequency by 16 (393.216 MHz).

4.4 PC0-PC2, CMC

CMC shows the bus manager function which corresponds to the c bit of the Self_ID packet and the Contender bit in the PHY register when the input is High.

The value of CMC can be changed with software through the Link layer; this pin sets the initial value during Power-on Reset. Use a pull-up or pull-down resistor of 10 k Ω , based on the device's specification.

The PC0-PC2 pin corresponds to the power field of the Self_ID packet and Pwr_class in the PHY register. Refer to Section 4.3.4.1 of the IEEE1394-1995 specification for information regarding the Pwr_class. The value of Pwr can be changed with software through the Link layer; this pin sets the initial value during Power-on Reset. Use a pull-up or pull-down resistor of 10 k Ω based on the application.

4.5 $\overline{\text{P_RESETB}}$

Connect an external capacitor of 0.1 μ F between the pins $\overline{\text{P_RESETB}}$ and GND. If the voltage drops below 0 V, a reset pulse is generated. All of the circuits are initialized, including the contents of the PHY register.

4.6 RI0, RI1

Connect an external resistor of 9.1 k Ω \pm 0.5 % to limit the LSI's current.

5. SERIAL ROM INTERFACE

The μPD72870A provides a serial ROM interface to initialize the 1394 Global Unique ID Register and the PCI/Cardbus Mode Configuration registers from a serial EEPROM.

The table 5-1 shows the serial EEPROM memory map required for initializing their registers.

5.1 Serial EEPROM Register

Register Address	Register Name	R/W
Base address + 0x930	SUBID register	R/W
Base address + 0x934	LATVAL register	R/W
Base address + 0x938	W_GUIDHi register	R/W
Base address + 0x93C	W_GUIDLo register	R/W
Base address + 0x940	Parameters Write register	R/W
Base address + 0x950	W_LAT register	R/W
Base address + 0x954	W_GENERAL register	R/W
Base address + 0x960	W_PHYS register	R/W
Base address + 0x980	W_CIS register	R/W

Remark Base address : Base Address 0 in Configuration register

5.2 Serial EEPROM Register Description

(1) SUBID register (Base address + 0x930)

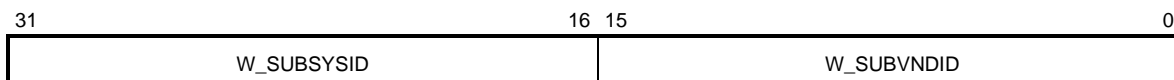

Field	Bits	R/W	Default value	Description
W_SUBSYSID	31-16	R/W	0063H	Subsystem ID value. The value is loaded into Subsystem ID register in Configuration register (Offset+2CH bit 31-16).
W_SUBVNDID	15-0	R/W	1033H	Subsystem Vendor ID value. The value is loaded into Subsystem Vendor ID register in Configuration register (Offset+2CH bit 15-0).

(2) LATVAL register (Base address + 0x934)

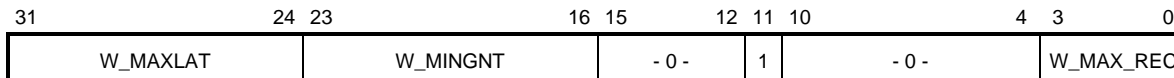

Field	Bits	R/W	Default value	Description
W_MAXLAT	31-24	R/W	00H	Max Latency value. The value is loaded into Max Latency register in Configuration register (Offset+3CH bit 31-24).
W_MINGNT	23-16	R/W	00H	Min Grant value. The value is loaded into Min Grant register in Configuration register (Offset+3CH bit 23-16).
-	15-12	-	-	Reserved. Write 0 to these bits.
	11	-	-	Reserved. Write 1 to this bit.
	10-4	-	-	Reserved. Write 0 to these bits.
W_MAX_REC	3-0	R/W	9H	MAX_REC value. The value is loaded into the max_rec field of OHCI BusOption register in OHCI register (Offset+020H bit 15-12).

(3) W_GUIDHi register (Base address + 0x938)

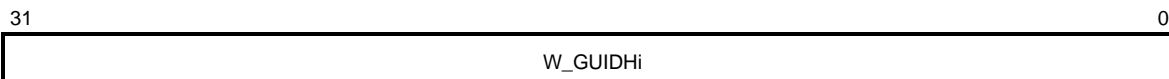

Field	Bits	R/W	Default value	Description
W_GUIDHi	31-0	R/W	Undefined	GlobalUniqueIDHi value. The value is loaded into OHCI GlobalUniqueIDHi register in OHCI register (Offset+024H bit 31-0). Please refer to the 1394 Open Host Controller Interface Specification/Release 1.0 [5.5.5].

(4) W_GUIDLo register (Base address + 0x93C)

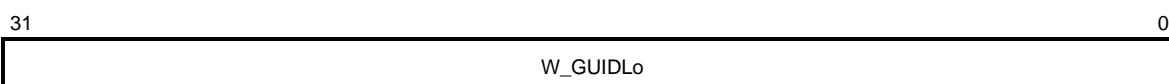

Field	Bits	R/W	Default value	Description
W_GUIDLo	31-0	R/W	Undefined	GlobalUniqueIDLo value. The value is loaded into GlobalUniqueIDLo register in OHCI register (Offset+028H bit 31-0). Please refer to the 1394 Open Host Controller Interface Specification/Release 1.0 [5.5.5].

(5) Parameters Write register (Base address + 0x940)

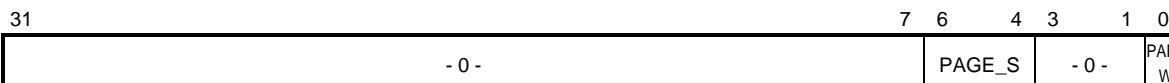

Field	Bits	R/W	Default value	Description
-	31-7	-	-	Reserved. Write 0 to these bits.
PAGE_S	6-4	R/W	000	Write register select page. The bit field returns zero when read. 000: Select SUBID register and LATVAL register. 001: Select W_GUIDHi register and W_GUIDLo register. 010: Select W_LAT register and W_GENERAL register (W_GENERAL_0). 011: Select W_GENERAL register (W_GENERAL_1 and W_GENERAL_2). 100: Select W_PHYS register (W_programPhyEnable, W_aPhyEnhanceEnable). 101: Select W_CIS register (W_CIS_EVEN - W_CIS_ODD).
-	3-1	-	-	Reserved. Write 0 to these bits.
PAR_W	0	R/W	0	Write control signal. The bit field returns zeros when read. 1: Write the value of select page defined PAGE_S. One write transaction is the units of 8 byte. 0: Ignored.

(6) W_LAT register (Base address + 0x950)

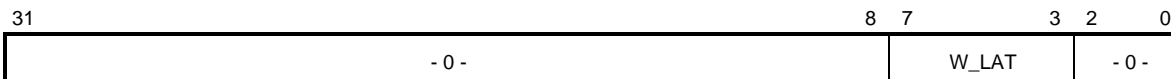

Field	Bits	R/W	Default value	Description
-	31-8	-	-	Reserved. Write 0 to these bits.
W_LAT	7-3	R/W	00000	Latency timer value. The value is loaded into Latency Timer in Configuration register (Offset+0CH bit 15-8) when using as Cardbus mode (CARD_ON = 1). It is not loaded when using as PCI bus mode (CARD_ON = 0).
-	2-0	-	-	Reserved. Write 0 to these bits.

(7) W_GENERAL register (Base address + 0x954 - 0x95C)

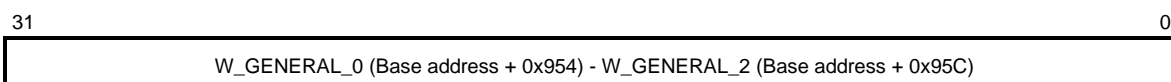

Field	Bits	R/W	Default value	Description
W_GENERAL_0 - W_GENERAL_2	31-0	R/W	Undefined	User define value. The value is loaded into GENERAL_registerB - D in Configuration register (Offset+70H - 7BH).

(8) W_PHYS register (Base address + 0x960)

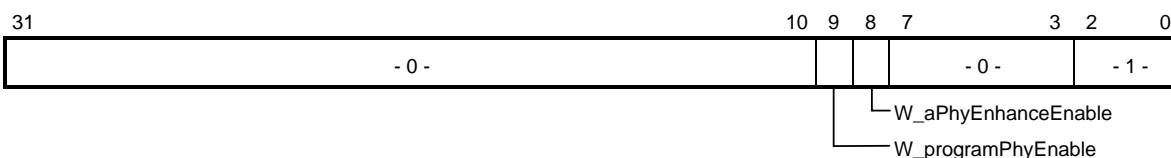

Field	Bits	R/W	Default value	Description
-	31-10	-	-	Reserved. Write 0 to these bits.
W_programPhyEnable	9	R/W	1	programPhyEnable bit. The bit is loaded into HCControl registers in OHCI register ((Offset+50H bit 23) and (54H bit 23)). Please refer to the 1394 Open Host Controller Interface Specification/Release 1.0 [5.7]. 1: P1394a enhancement is supported. 0: P1394a enhancement is not supported.
W_aPhyEnhanceEnable	8	R/W	0	aPhyEnhanceEnable bit. The bit is loaded into HCControl registers in OHCI register ((Offset+50H bit 23) and (54H bit 23)).
-	7-3	-	-	Reserved. Write 0 to these bits.
-	2-0	-	-	Reserved. Write 1 to these bits.

(9) W_CIS register (Base address + 0x980 - 0x984)

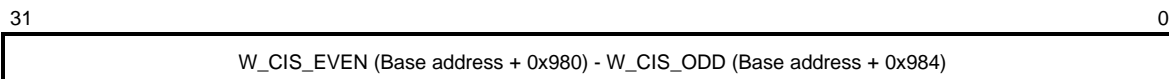

Field	Bits	R/W	Default value	Description
W_CIS_EVEN - W_CIS_ODD	31-0	R/W	Undefined	CIS Area value. The value is loaded into CIS Area in Configuration register (Offset+80H - FCH).

Table 5-1. Serial EEPROM Memory Map

Byte address	Bit							
	7	6	5	4	3	2	1	0
0	W_SUBSYSID(31 : 24)							
1	W_SUBSYSID(23 : 16)							
2	W_SUBVNDID(15 : 8)							
3	W_SUBVNDID(7 : 0)							
4	W_MAXLAT(31 : 24)							
5	W_MINGNT(23 : 16)							
6	0	0	0	0	1	0	0	0
7	0	0	0	0	W_MAX_REC(3 : 0)			
8	W_GUIDHi(31 : 24)							
9	W_GUIDHi(23 : 16)							
A	W_GUIDHi(15 : 8)							
B	W_GUIDHi(7 : 0)							
C	W_GUIDLo(31 : 24)							
D	W_GUIDLo(23 : 16)							
E	W_GUIDLo(15 : 8)							
F	W_GUIDLo(7 : 0)							
10	0	0	0	0	0	0	0	0
11	0	0	0	0	0	0	0	0
12	0	0	0	0	0	0	0	0
13	W_LAT(7 : 3)					0	0	0
14	W_GENERAL_0(31 : 24)							
15	W_GENERAL_0(23 : 16)							
16	W_GENERAL_0(15 : 8)							
17	W_GENERAL_0(7 : 0)							
:	:							
:	:							
1C	W_GENERAL_2(31 : 24)							
1D	W_GENERAL_2(23 : 16)							
1E	W_GENERAL_2(15 : 8)							
1F	W_GENERAL_2(7 : 0)							
20	0	0	0	0	0	0	0	0
21	0	0	0	0	0	0	0	0
22	0	0	0	0	0	0	WPE	WPEE
23	0	0	0	0	0	1	1	1
:	:							
:	:							
28	W_CIS_0(31 : 24)							
29	W_CIS_0(23 : 16)							
2A	W_CIS_0(15 : 8)							
2B	W_CIS_0(7 : 0)							
:	:							
:	:							
A4	W_CIS_31(31 : 24)							
A5	W_CIS_31(23 : 16)							
A6	W_CIS_31(15 : 8)							
A7	W_CIS_31(7 : 0)							

WPE: W_programPhyEnable, WPEE: W_aPhyEnhanceEnable

5.3 Load Control

GROM_EN	CARD_ON	CIS_ON	Description
0	X	X	No loading.
1	0	1	W_SUBSYSID, W_SUBVNDID, W_MAXLAT, W_MINGNT, W_MAX_REC, W_GUIDHi/Lo, W_LAT, W_GENERAL_0 - W_GENERAL_2, W_programPhyEnable, W_aPhyEnhanceEnable are loaded.
1	0	0	All parameters (W_SUBSYSID, W_SUBVNDID, W_MAXLAT, W_MINGNT, W_MAX_REC, W_GUIDHi/Lo, W_LAT, W_GENERAL_0 - W_GENERAL_2, W_programPhyEnable, W_aPhyEnhanceEnable, W_CIS_EVEN - W_CIS_ODD) are loaded.
1	1	X	

5.4 Programming Sequence Example

The example of programming sequence to the serial EEPROM is shown below.

- (1) Write SUBID register. **Note1**
- (2) Write LATVAL register. **Note1**
- (3) Write PAGE_S = 000 and PAR_W = 1 on Parameters Write register. **Note1**
- (4) Wait over 13 ms for serial EEPROM access time. **Note1**
- (5) Write W_GUIDHi register. **Note2**
- (6) Write W_GUIDLo register. **Note2**
- (7) Write PAGE_S = 001 and PAR_W = 1 on Parameters Write register. **Note2**
- (8) Wait over 13 ms for serial EEPROM access time. **Note2**
- (9) Write W_LAT register. **Note3**
- (10) Write W_GENERAL register (W_GENERAL_0). **Note3**
- (11) Write PAGE_S = 010 and PAR_W = 1 on Parameters Write register. **Note3**
- (12) Wait over 13 ms for serial EEPROM access time. **Note3**
- (13) Write W_GENERAL register (W_GENERAL_1, W_GENERAL_2). **Note4**
- (14) Write PAGE_S = 011 and PAR_W = 1 on Parameters Write register. **Note4**
- (15) Wait over 13 ms for serial EEPROM access time. **Note4**
- (16) Write W_CIS register. **Note5**
- (17) Write PAGE_S = 100 and PAR_W = 1 on Parameters Write register. **Note5**
- (18) Wait over 30 ms for serial EEPROM access time. **Note5**
- (19) Complete to write parameters into Serial EEPROM.
- (20) Parameters are loaded from serial EEPROM after PCI reset.

- Notes**
- 1.** If none of W_SUBSYSID, W_SUBVNDID, W_MAXLAT, W_MINGNT, W_HOLD_TIMER, W_MAX_REC in serial EEPROM are changed, (1)-(4) transactions don't need.
 - 2.** If none of W_GUIDHi, W_GUIDLo in serial EEPROM are changed, (5)-(8) transactions don't need.
 - 3.** If none of W_LAT, W_GENERAL_0 in serial EEPROM are changed, (9)-(12) transactions don't need.
 - 4.** If none of W_GENERAL_1, W_GENERAL_2 in serial EEPROM are changed, (13)-(15) transactions don't need.
 - 5.** If none of W_CIS_0 - W_CIS_31 in serial EEPROM are changed, (16)-(18) transactions don't need. One write transaction (Parameters Write register : PAGE_S = 100 and PAR_W = 1) is the units of 8 byte . If more than 8 byte write, you need to repeat (16)-(18). *

- *: • Write W_CIS_0, W_CIS_1 register.
- Write PAGE_S = 100 and PAR_W = 1 on Parameters Write register.
 - Wait over 30 ms for serial EEPROM access time.
 -
- Write W_CIS_30, W_CIS_31 register.
- Write PAGE_S = 100 and PAR_W = 1 on Parameters Write register.
 - Wait over 30 ms for serial EEPROM access time.

6. ELECTRICAL SPECIFICATIONS

Absolute Maximum Ratings

Parameter	Symbol	Condition	Rating	Unit
Power supply voltage	V _{DD}		-0.5 to +4.6	V
Input voltage	V _I	LVTTL @ (V _I < 0.5 V + V _{DD})	-0.5 to +4.6	V
		PCI @ (V _I < 3.0 V + V _{DD})	-0.5 to +6.6	V
Output voltage	V _O	LVTTL @ (V _O < 0.5 V + V _{DD})	-0.5 to +4.6	V
		PCI @ (V _O < 3.0 V + V _{DD})	-0.5 to +6.6	V
Operating ambient temperature	T _A		0 to +70	°C
Storage temperature	T _{stg}		-65 to +150	°C

Caution Product quality may suffer if the absolute maximum rating is exceeded even momentarily for any parameter. That is, the absolute maximum ratings are rated values at which the product is on the verge of suffering physical damage, and therefore the product must be used under conditions that ensure that the absolute maximum ratings are not exceeded.

Recommended Operating Ranges

Parameter	Symbol	Condition	Rating	Unit
Power supply voltage	V _{DD}	Used to clamp reflection on PCI bus.	4.5 to 5.5	V
			3.0 to 3.6	V
Operating ambient temperature	T _A		0 to +70	°C

DC Characteristics (V_{DD} = 3.3 V ± 10 %, V_{SS} = 0 V, T_A = 0 to +70°C)

Parameter	Symbol	Condition	MIN.	TYP.	MAX.	Unit
High-level input voltage	V _{IH}		2.0		V _{DD} +0.5	V
Low-level input voltage	V _{IL}		-0.5		+0.8	V
High-level output current	I _{OH}	V _{OH} =2.4 V Pin No. LQFP:153,154 FBGA:A4,B4	-6			mA
		Pin No. LQFP:74,76-79,83,84,92 FBGA:L14,P15,P16, R13-R15,T14,T15	-9			mA
Low-level output current	I _{OL}	V _{OL} =0.4 V Pin No. LQFP:153,154 FBGA:A4,B4	6			mA
		Pin No. LQFP:74,76-79,83,84,92 FBGA:L14,P15,P16, R13-R15,T14,T15	9			mA
Input leakage current	I _L	V _{IN} = V _{DD} OR GND			±10.0	μA
Supply current	I _{DD}	3 ports, S400, V _{DD} = 3.3 V			280	mA
PCI interface						
High-level input voltage	V _{IH}		2.0		5.5	V
Low-level input voltage	V _{IL}		-0.5		+0.8	V
High-level output current	I _{OH}	V _{OH} = 2.4 V	-2			mA
Low-level output current	I _{OL}	V _{OL} = 0.4 V	9			mA
Input leakage current	I _L	V _{IN} = V _{DD} OR GND			±10.0	μA
Cable interface						
Differential input voltage	V _{ID}	Cable input, 100 Mbps operation	142		260	mV
		Cable input, 200 Mbps operation	132		260	mV
		Cable input, 400 Mbps operation	118		260	mV
TpB common mode input voltage	V _{ICM}	100 Mbps speed signaling off	1.165		2.515	V
		200 Mbps speed signaling	0.935		2.515	V
		400 Mbps speed signaling	0.523		2.515	V
Differential output voltage	V _{OD}	Cable output (Test load 55Ω)	172.0		265.0	mV
TpA common mode output voltage	V _{OCM}	100 Mbps speed signaling off	1.665		2.015	V
		200 Mbps speed signaling	1.438		2.015	V
		400 Mbps speed signaling	1.030		2.015	V
TpA common mode output current	I _{CM}	100 Mbps speed signaling off	-0.81		+0.44	mA
		200 Mbps speed signaling	-4.84		-2.53	mA
		400 Mbps speed signaling	-12.40		-8.10	mA
Power status threshold voltage	V _{TH}	CPS			7.5	V
TpBias output voltage	V _{TPBIAS}		1.665		2.015	V

- Remarks**
1. Digital core runs at 3.3 V.
 2. PCI Interface can run at 5 or 3.3 V, depending on the choice of 5 V-PCI or 3.3 V-PCI.
 3. All other I/Os are 3.3 V driving, and 5 V tolerant.
 4. 5 V are used only for 5 V-PCI clamping diode.

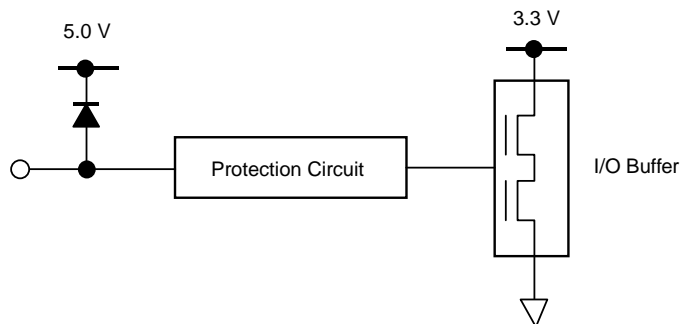

AC Characteristics

PCI Interface

See PCI local bus specification Revision 2.1.

Serial ROM Interface

See AT24C01A/02/04/08/16 Spec. Sheet.

7. APPLICATION CIRCUIT EXAMPLE

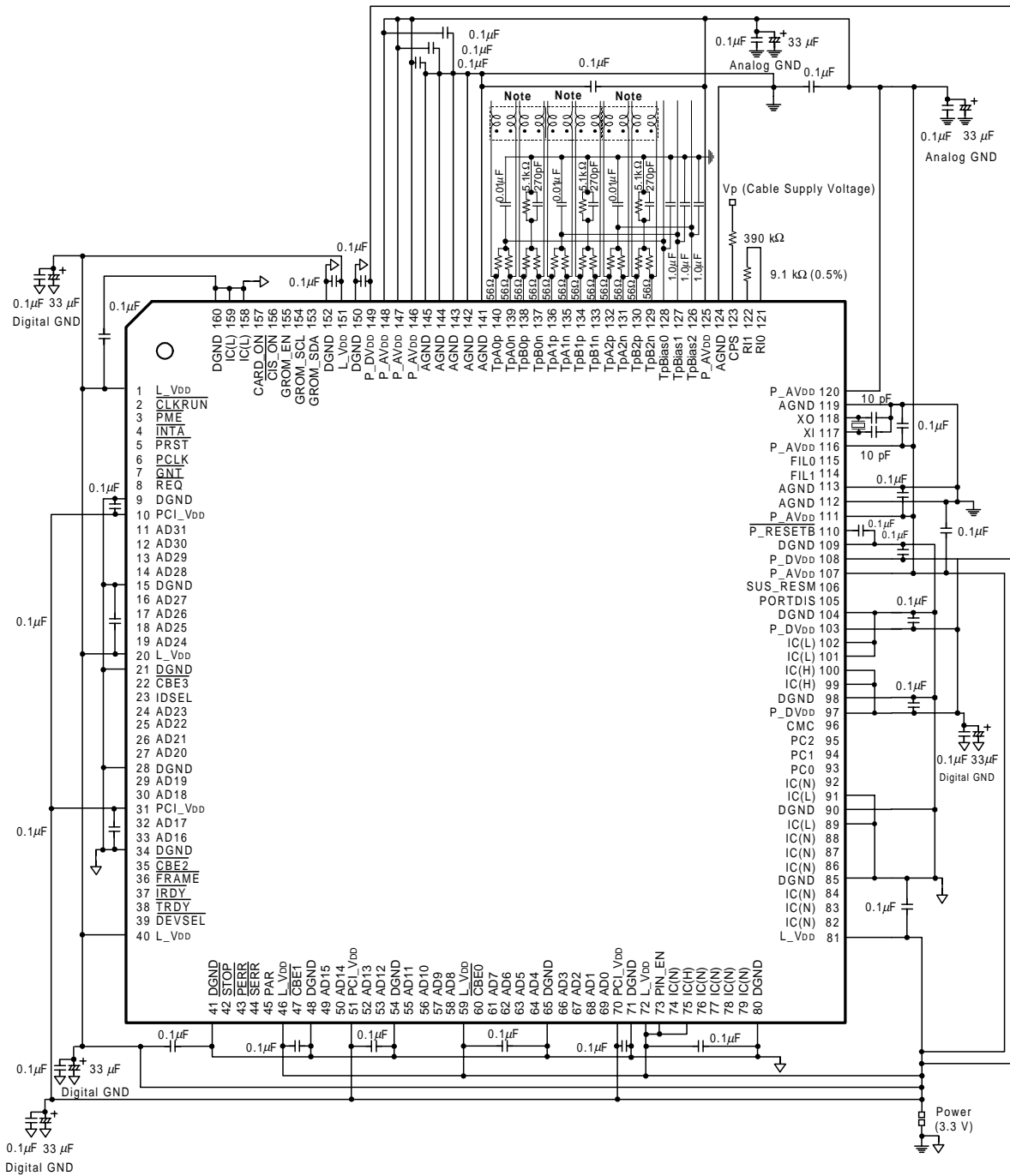

8. PACKAGE DRAWINGS

160-PIN PLASTIC LQFP (FINE PITCH) (24x24)

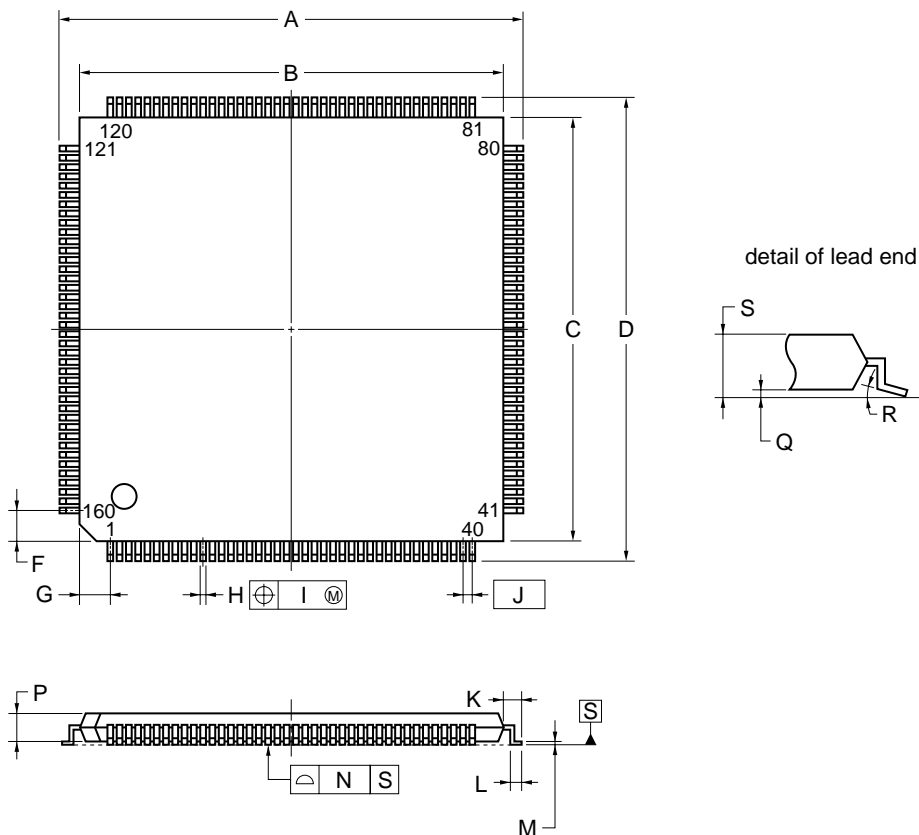

NOTE

Each lead centerline is located within 0.10 mm of its true position (T.P.) at maximum material condition.

ITEM	MILLIMETERS
A	26.0±0.2
B	24.0±0.2
C	24.0±0.2
D	26.0±0.2
F	2.25
G	2.25
H	0.22 ^{+0.05} _{-0.04}
I	0.10
J	0.5 (T.P.)
K	1.0±0.2
L	0.5±0.2
M	0.145 ^{+0.055} _{-0.045}
N	0.10
P	1.4±0.1
Q	0.125±0.075
R	3° ^{+7°} _{-3°}
S	1.7 MAX.

S160GM-50-8ED-3

192-PIN PLASTIC FBGA (14x14)

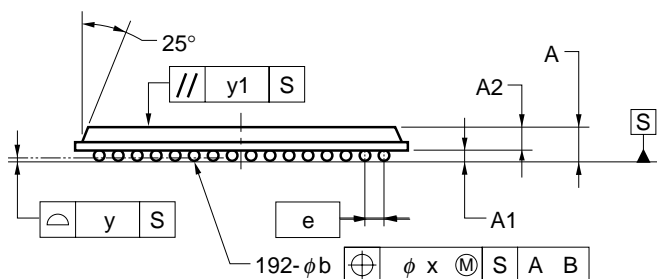
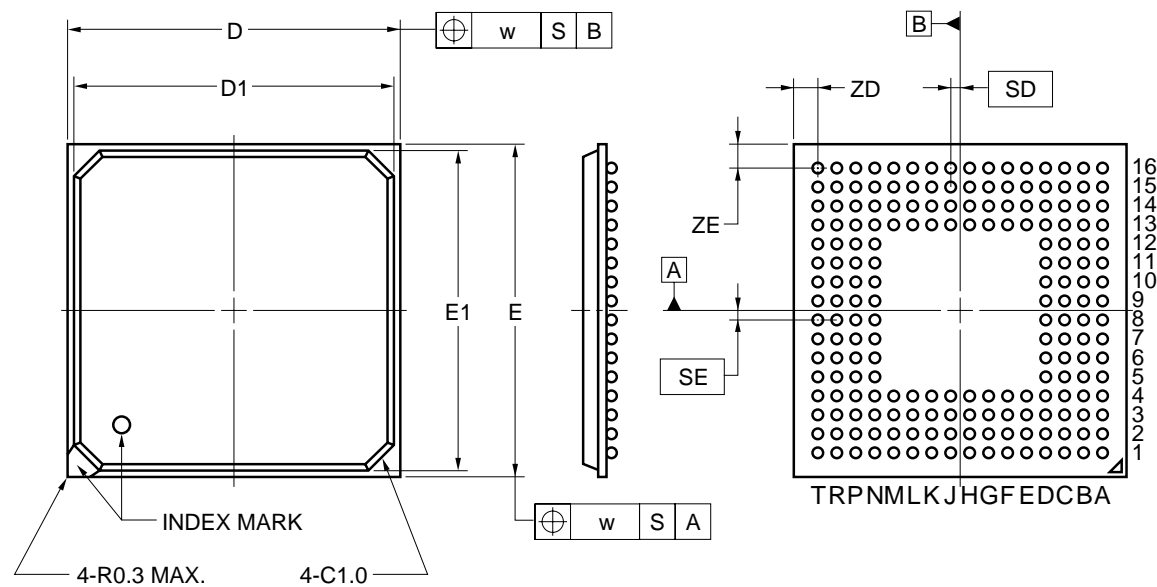

ITEM	MILLIMETERS
D	14.0±0.1
D1	13.4
E	14.0±0.1
E1	13.4
w	0.20
e	0.8
A	1.31±0.15
A1	0.35±0.10
A2	0.96
b	0.5 ^{+0.05} _{-0.10}
x	0.08
y	0.10
y1	0.2
SD	0.4
SE	0.4
ZD	1.0
ZE	1.0

P192F1-80-FA2

[MEMO]

NOTES FOR CMOS DEVICES

① PRECAUTION AGAINST ESD FOR SEMICONDUCTORS

Note:

Strong electric field, when exposed to a MOS device, can cause destruction of the gate oxide and ultimately degrade the device operation. Steps must be taken to stop generation of static electricity as much as possible, and quickly dissipate it once, when it has occurred. Environmental control must be adequate. When it is dry, humidifier should be used. It is recommended to avoid using insulators that easily build static electricity. Semiconductor devices must be stored and transported in an anti-static container, static shielding bag or conductive material. All test and measurement tools including work bench and floor should be grounded. The operator should be grounded using wrist strap. Semiconductor devices must not be touched with bare hands. Similar precautions need to be taken for PW boards with semiconductor devices on it.

② HANDLING OF UNUSED INPUT PINS FOR CMOS

Note:

No connection for CMOS device inputs can be cause of malfunction. If no connection is provided to the input pins, it is possible that an internal input level may be generated due to noise, etc., hence causing malfunction. CMOS devices behave differently than Bipolar or NMOS devices. Input levels of CMOS devices must be fixed high or low by using a pull-up or pull-down circuitry. Each unused pin should be connected to V_{DD} or GND with a resistor, if it is considered to have a possibility of being an output pin. All handling related to the unused pins must be judged device by device and related specifications governing the devices.

③ STATUS BEFORE INITIALIZATION OF MOS DEVICES

Note:

Power-on does not necessarily define initial status of MOS device. Production process of MOS does not define the initial operation status of the device. Immediately after the power source is turned ON, the devices with reset function have not yet been initialized. Hence, power-on does not guarantee out-pin levels, I/O settings or contents of registers. Device is not initialized until the reset signal is received. Reset operation must be executed immediately after power-on for devices having reset function.

EEPROM and Firewarden are trademarks of NEC Corporation.

The export of this product from Japan is prohibited without governmental license. To export or re-export this product from a country other than Japan may also be prohibited without a license from that country. Please call an NEC sales representative.

- **The information in this document is subject to change without notice. Before using this document, please confirm that this is the latest version.**
 - No part of this document may be copied or reproduced in any form or by any means without the prior written consent of NEC Corporation. NEC Corporation assumes no responsibility for any errors which may appear in this document.
 - NEC Corporation does not assume any liability for infringement of patents, copyrights or other intellectual property rights of third parties by or arising from use of a device described herein or any other liability arising from use of such device. No license, either express, implied or otherwise, is granted under any patents, copyrights or other intellectual property rights of NEC Corporation or others.
 - Descriptions of circuits, software, and other related information in this document are provided for illustrative purposes in semiconductor product operation and application examples. The incorporation of these circuits, software, and information in the design of the customer's equipment shall be done under the full responsibility of the customer. NEC Corporation assumes no responsibility for any losses incurred by the customer or third parties arising from the use of these circuits, software, and information.
 - While NEC Corporation has been making continuous effort to enhance the reliability of its semiconductor devices, the possibility of defects cannot be eliminated entirely. To minimize risks of damage or injury to persons or property arising from a defect in an NEC semiconductor device, customers must incorporate sufficient safety measures in its design, such as redundancy, fire-containment, and anti-failure features.
 - NEC devices are classified into the following three quality grades:
"Standard", "Special", and "Specific". The Specific quality grade applies only to devices developed based on a customer designated "quality assurance program" for a specific application. The recommended applications of a device depend on its quality grade, as indicated below. Customers must check the quality grade of each device before using it in a particular application.
 - Standard: Computers, office equipment, communications equipment, test and measurement equipment, audio and visual equipment, home electronic appliances, machine tools, personal electronic equipment and industrial robots
 - Special: Transportation equipment (automobiles, trains, ships, etc.), traffic control systems, anti-disaster systems, anti-crime systems, safety equipment and medical equipment (not specifically designed for life support)
 - Specific: Aircraft, aerospace equipment, submersible repeaters, nuclear reactor control systems, life support systems or medical equipment for life support, etc.
- The quality grade of NEC devices is "Standard" unless otherwise specified in NEC's Data Sheets or Data Books. If customers intend to use NEC devices for applications other than those specified for Standard quality grade, they should contact an NEC sales representative in advance.