

FEATURES

- **LOW POWER CONSUMPTION:** 20 mW
- **WIDE BAND APPLICATION:** 0.5 to 1.7 GHz
- **SINGLE SUPPLY VOLTAGE:** $V_{CC} = 3\text{ V} \pm 10\%$
- **SMALL PACKAGE**
- **SUITABLE FOR HAND HELD (BATTERY) APPLICATIONS**

DESCRIPTION

The UPB1502GR prescaler operates from 0.5 to 1.7 GHz at division ratios of 64, 65, 128 or 129. The 3 volt, 7 mA DC power requirements of this device make it highly desirable for hand-held, battery-operated systems. The low cost 8-pin plastic package is suitable for surface mount applications.

RECOMMENDED

OPERATING CONDITIONS ($T_A = 25^\circ\text{C}$)

SYMBOL	PARAMETER	UNITS	RATINGS
V _{CC}	Supply Voltage	V	3.0±0.3
T _{OP}	Operating Temperature	°C	-40 to +85

TEST CIRCUIT

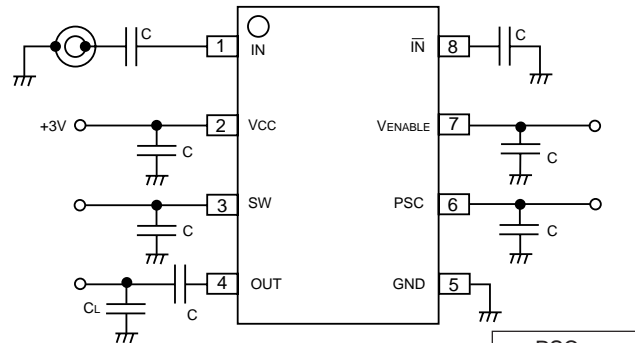

		PSC	
		V _{CC}	GND
SW	V _{CC}	1/64	1/65
	Open/GND	1/128	1/129

Notes:

1. All Capacitors 1000 pF except load capacitor on output should be 8 pF. Capacitors on SW and PSC are not required if these pins are grounded.
2. Connect VENABLE pin to +3 volts for normal operation. Connect to GND to disable device.
3. To minimize self-oscillation, circuit board traces to the input and output pins should be isolated from each other as much as possible.

ELECTRICAL CHARACTERISTICS ($T_A = -40$ to $+85^\circ\text{C}$, $V_{CC} = 2.7$ to 3.3 V)

PART NUMBER PACKAGE OUTLINE			UPB1502GR, UPB1502GR(1) G08		
SYMBOLS	PARAMETERS AND CONDITIONS	UNITS	MIN	TYP	MAX
I _{CC}	Supply Current $V_{ENABLE} = V_{CC}$ $V_{ENABLE} \leq 0.8\text{ V}$	mA µA	3.2	6.7 5	11.0 20
f _{IN}	Input Frequency at P _{IN} = -15 to -11 dBm (UPB1502GR) P _{IN} = -11 to -6 dBm (UPB1502GR) P _{IN} = -6 to 0 dBm (UPB1502GR) P _{IN} = -15 to -14 dBm (UPB1502GR(1)) P _{IN} = -14 to -11 dBm (UPB1502GR(1)) P _{IN} = -11 to -9 dBm (UPB1502GR(1)) P _{IN} = -9 to -1 dBm (UPB1502GR(1)) P _{IN} = -1 to 0 dBm (UPB1502GR(1))	GHz	0.8 0.5 0.5 0.8 0.8 0.5 0.5 0.5		1.7 1.7 1.5 1.7 2.0 2.0 1.7 1.5
P _{IN}	Input Power at f _{IN} = 0.5 to 0.8 GHz f _{IN} = 0.8 to 1.5 GHz f _{IN} = 1.5 to 1.7 GHz (UPB1502GR) f _{IN} = 1.5 to 1.7 GHz (UPB1502GR(1)) f _{IN} = 1.7 to 2.0 GHz (UPB1502GR(1))	dBm	-11 -15 -15 -15 -14		0 0 -6 -1 -9
V _{OUT}	Output Voltage Swing, C _L = 8 pF	V _{PP}	0.8	1.1	
V _{MH}	Modulus Control, Input High (PSC)	V	2.5		
V _{ML}	Modulus Control, Input Low (PSC)	V			0.8
V _{DH}	Divide Ratio Control, Input High (SW)	V	V _{CC}		
V _{DL}	Divide Ratio Control, Input Low (SW) ¹	V		OPEN	
T _{SET}	Modulus Set-up Time (PSC) f _{IN} = 1.7 GHz	ns		11	
R _{TH} (CH-A)	Thermal Resistance (Channel to Ambient)	°C/W			260

Note:

1. GND is acceptable.

UPB1502GR, UPB1502GR(1)

ABSOLUTE MAXIMUM RATINGS¹ (T_A = 25°C)

SYMBOLS	PARAMETERS	UNITS	RATINGS
V _{CC}	Supply Voltage	V	-0.5 to 6.0
V _{IN}	Input Voltage	V	-0.5 to V _{CC} + 0.5
P _T	Total Power Dissipation ²	mW	250
T _{OP}	Operating Temperature	°C	-40 to +85
T _{STG}	Storage Temperature	°C	-65 to +150

Notes:

- Operation above any one of these parameters may result in permanent damage.
- Mounted on 50 x 50 x 1.6 mm epoxy glass circuit board, (T_A = 85°C)

INTERNAL BLOCK DIAGRAM

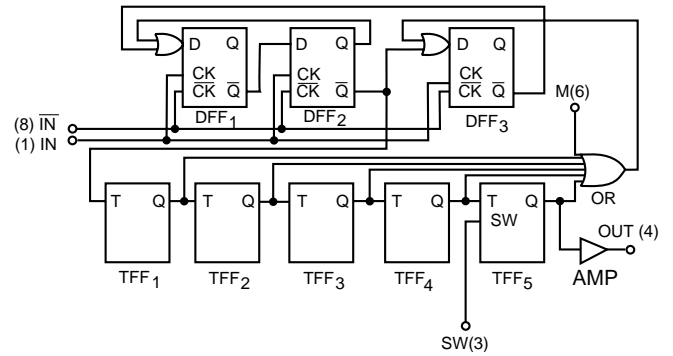

TYPICAL PERFORMANCE CURVES

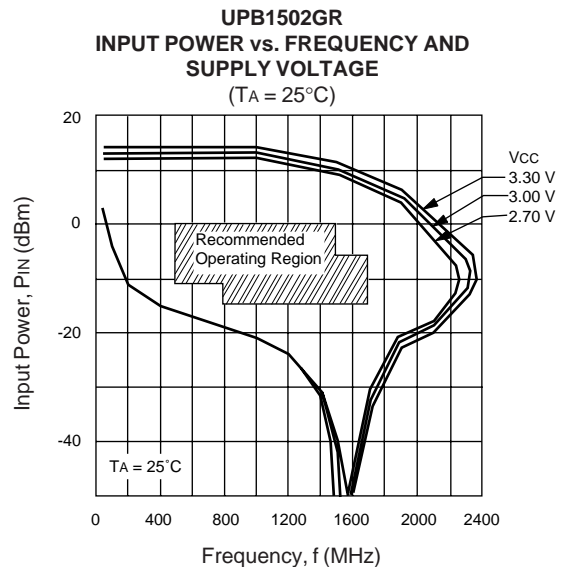
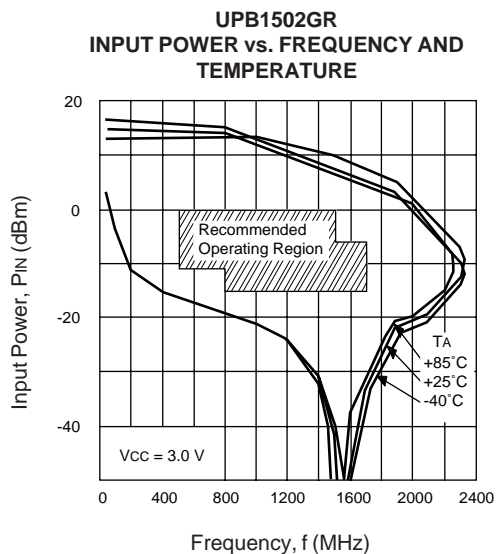
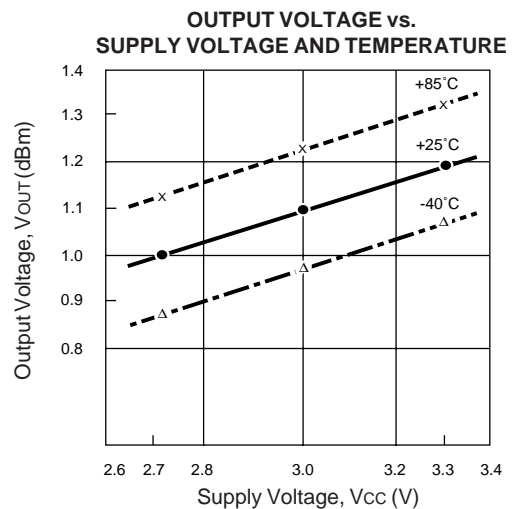
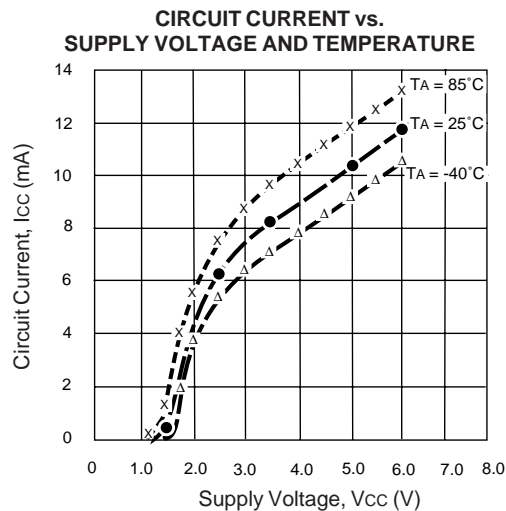

TYPICAL PERFORMANCE CURVES

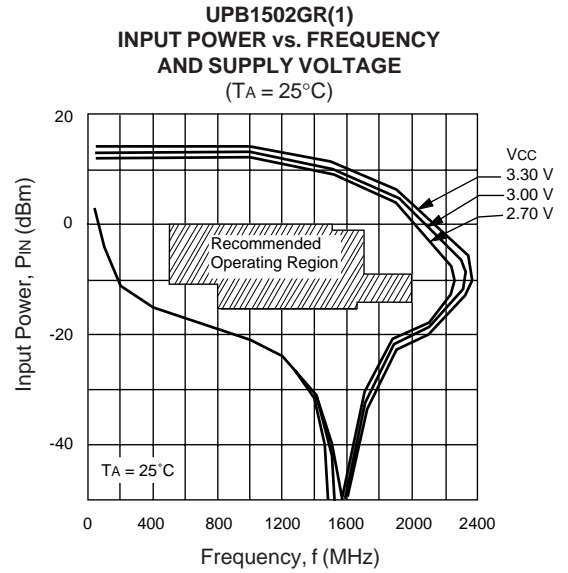
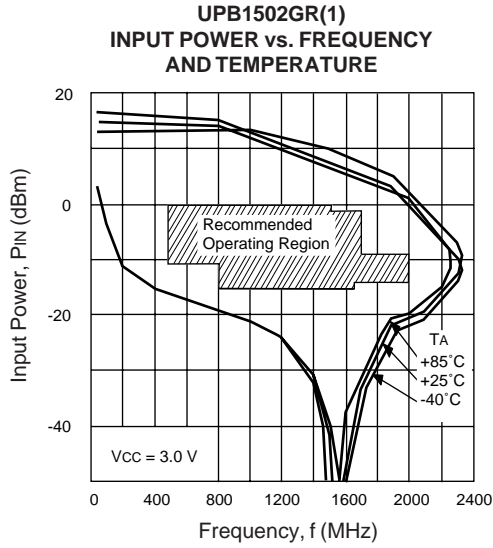

TYPICAL SCATTERING PARAMETERS (TA = 25°C)

Divide-by-sixty-four mode
Vcc = 3.0 V, Icc = 6.7 mA

SW = High, PSC = High

FREQUENCY			S11			FREQUENCY			S22		
(MHz)	MAG	ANG	(MHz)	MAG	ANG	(MHz)	MAG	ANG	(MHz)	MAG	ANG
250	0.811	-13	50	0.976	-6	100	0.924	-12			
500	0.778	-26	150	0.817	-17	200	0.733	-16			
750	0.733	-41	250	0.693	-15						
1000	0.654	-54									
1250	0.585	-68									
1500	0.511	-82									
1750	0.484	-95									
2000	0.462	-116									
2250	0.447	-144									
2500	0.430	-173									

Divide-by-one-twenty-eight mode
Vcc = 3.0 V, Icc = 6.7 mA

SW = Low, PSC = High

FREQUENCY			S11			FREQUENCY			S22		
(MHz)	MAG	ANG	(MHz)	MAG	ANG	(MHz)	MAG	ANG	(MHz)	MAG	ANG
250	0.801	-13	50	0.980	-6	100	0.921	-13			
500	0.767	-26	150	0.801	-18	200	0.712	-18			
750	0.724	-41	250	0.666	-16						
1000	0.637	-54									
1250	0.573	-68									
1500	0.505	-82									
1750	0.474	-96									
2000	0.459	-116									
2250	0.442	-145									
2500	0.425	-172									

Divide-by-sixty-five mode
Vcc = 3.0 V, Icc = 6.7 mA

SW = High, PSC = Low

FREQUENCY			S11			FREQUENCY			S22		
(MHz)	MAG	ANG	(MHz)	MAG	ANG	(MHz)	MAG	ANG	(MHz)	MAG	ANG
250	0.810	-13	50	0.972	-6	100	0.924	-12			
500	0.775	-26	150	0.817	-17	200	0.733	-16			
750	0.731	-41	250	0.693	-15						
1000	0.652	-55									
1250	0.579	-68									
1500	0.501	-82									
1750	0.465	-96									
2000	0.454	-116									
2250	0.436	-144									
2500	0.420	-174									

Divide-by-one-twenty-nine mode
Vcc = 3.0 V, Icc = 6.7 mA

SW = Low, PSC = Low

FREQUENCY			S11			FREQUENCY			S22		
(MHz)	MAG	ANG	(MHz)	MAG	ANG	(MHz)	MAG	ANG	(MHz)	MAG	ANG
250	0.804	-13	50	0.981	-6	100	0.921	-13			
500	0.769	-26	150	0.801	-18	200	0.712	-17			
750	0.727	-41	250	0.667	-16						
1000	0.650	-54									
1250	0.581	-68									
1500	0.508	-82									
1750	0.467	-96									
2000	0.452	-115									
2250	0.435	-144									
2500	0.413	-171									

OUTLINE DIMENSIONS (Units in mm)

**UPB1502GR
PACKAGE OUTLINE G08**

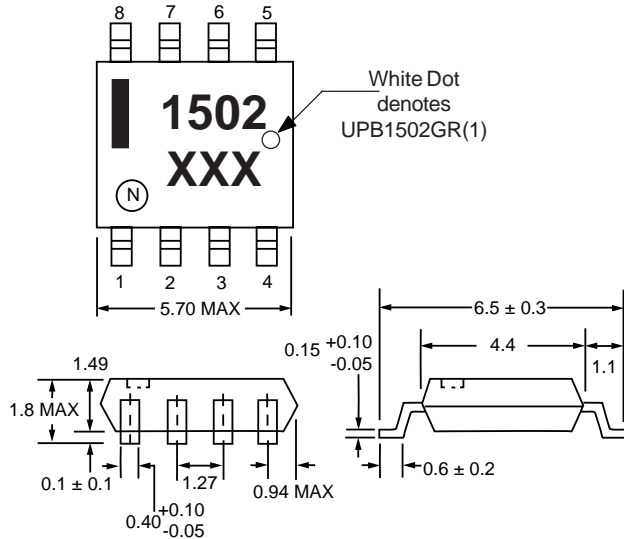

Lead Material: Alloy 42
Lead Plating: Lead-Tin Alloy

PIN CONNECTION	DESCRIPTION
1. IN	Signal Input
2. Vcc	DC Supply Voltage
3. SW	Divide Ratio Control*
4. OUT	Signal Output
5. GND	Ground
6. PSC	Modulus Control*
7. STBY	Stand By Operation*
8. $\overline{\text{IN}}$	Signal Input Reference

* See Application Circuit

ORDERING INFORMATION

PART NUMBER	QUANTITY
UPB1502GR-E1	2500/REEL
UPB1502GR(1)-E1	2500/REEL

Note:
Embossed tape, 12 mm wide.

EXCLUSIVE NORTH AMERICAN AGENT FOR **NEC** RF, MICROWAVE & OPTOELECTRONIC SEMICONDUCTORS

CEL CALIFORNIA EASTERN LABORATORIES • Headquarters • 4590 Patrick Henry Drive • Santa Clara, CA 95054-1817 • (408) 988-3500 • Telex 34-6393 • FAX (408) 988-0279
24-Hour Fax-On-Demand: 800-390-3232 (U.S. and Canada only) • Internet: <http://WWW.CEL.COM>

DATA SUBJECT TO CHANGE WITHOUT NOTICE

PRINTED IN USA ON RECYCLED PAPER -4/97