

TOSHIBA CMOS Digital Integrated Circuit Silicon Monolithic

TC4051BP, TC4051BF, TC4051BFN, TC4051BFT
TC4052BP, TC4052BF, TC4052BFN, TC4052BFT
TC4053BP, TC4053BF, TC4053BFN, TC4053BFT

TC4051B

Single 8-Channel Multiplexer/Demultiplexer

TC4052B

Differential 4-Channel
Multiplexer/Demultiplexer

TC4053B

Triple 2-Channel Multiplexer/Demultiplexer

TC4051B, TC4052B and TC4053B are multiplexers with capabilities of selection and mixture of analog signal and digital signal. TC4051B has 8 channels configuration. TC4052B has 4 channel × 2 configuration and TC4053B has 2 channel × 3 configuration. The digital signal to the control terminal turns "ON" the corresponding switch of each channel, with large amplitude ($V_{DD} - V_{EE}$) can be switched by the control signal with small logical amplitude ($V_{DD} - V_{SS}$). For example, in the case of $V_{DD} = 5\text{ V}$, $V_{SS} = 0\text{ V}$ and $V_{EE} = -5\text{ V}$, signals between -5 V and $+5\text{ V}$ can be switched from the logical circuit with single power supply of 5 volts. As the ON-resistance of each switch is low, these can be connected to the circuits with low input impedance.

Note: xxxFN (JEDEC SOP) is not available in Japan.

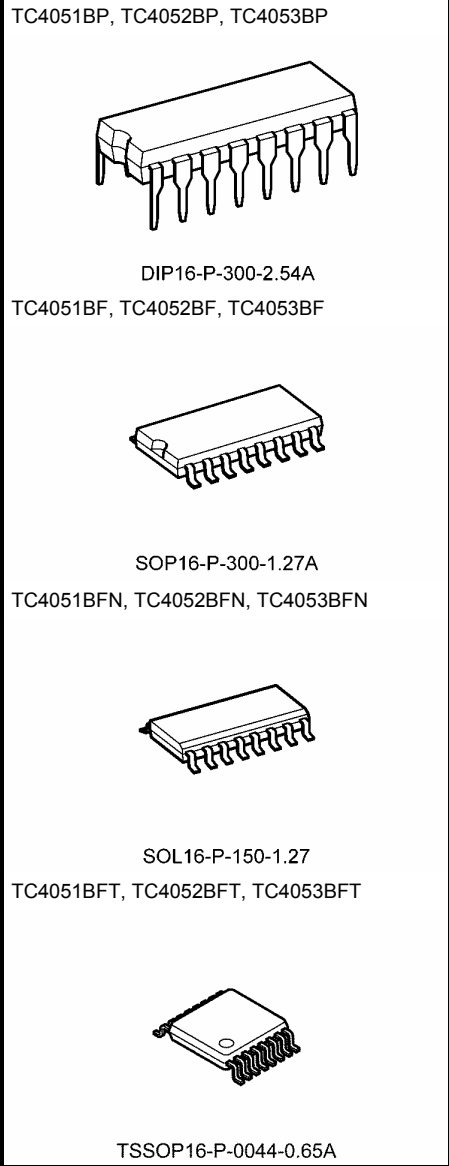

Weight	
DIP16-P-300-2.54A	: 1.00 g (typ.)
SOP16-P-300-1.27A	: 0.18 g (typ.)
SOL16-P-150-1.27	: 0.13 g (typ.)
TSSOP16-P-0044-0.65A	: 0.06 g (typ.)

Pin Assignment

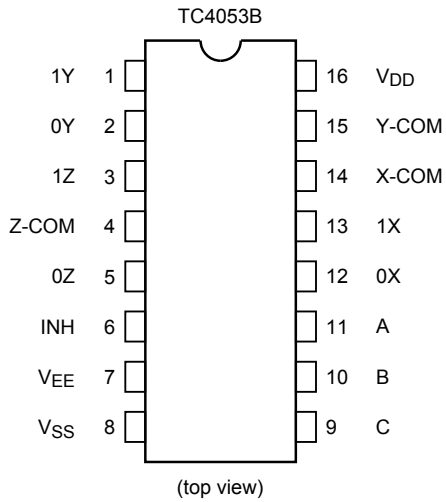
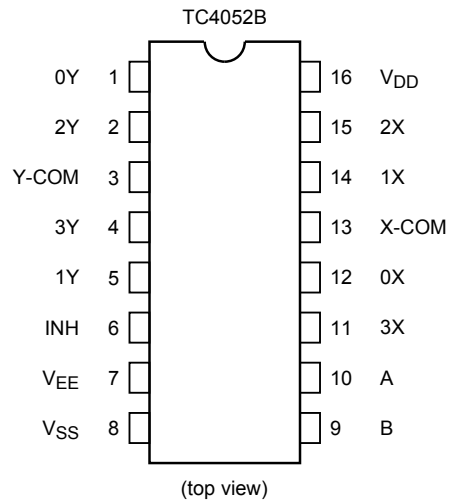
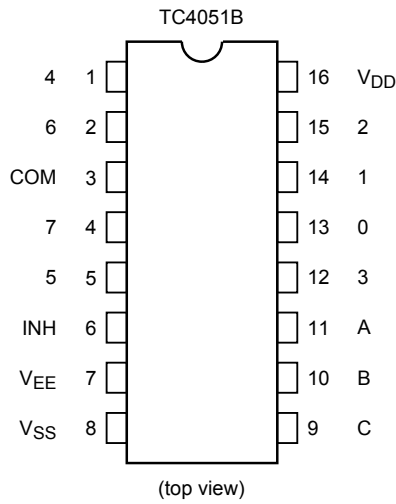

Truth Table

Control Inputs				"ON" Channel		
Inhibit	C Δ	B	A	TC4051B	TC4052B	TC4053B
L	L	L	L	0	0X, 0Y	0X, 0Y, 0Z
L	L	L	H	1	1X, 1Y	1X, 0Y, 0Z
L	L	H	L	2	2X, 2Y	0X, 1Y, 0Z
L	L	H	H	3	3X, 3Y	1X, 1Y, 0Z
L	H	L	L	4	—	0X, 0Y, 1Z
L	H	L	H	5	—	1X, 0Y, 1Z
L	H	H	L	6	—	0X, 1Y, 1Z
L	H	H	H	7	—	1X, 1Y, 1Z
H	X	X	X	None	None	None

X: Don't care

Δ : Except TC4052B

Logic Diagram

TC4051B

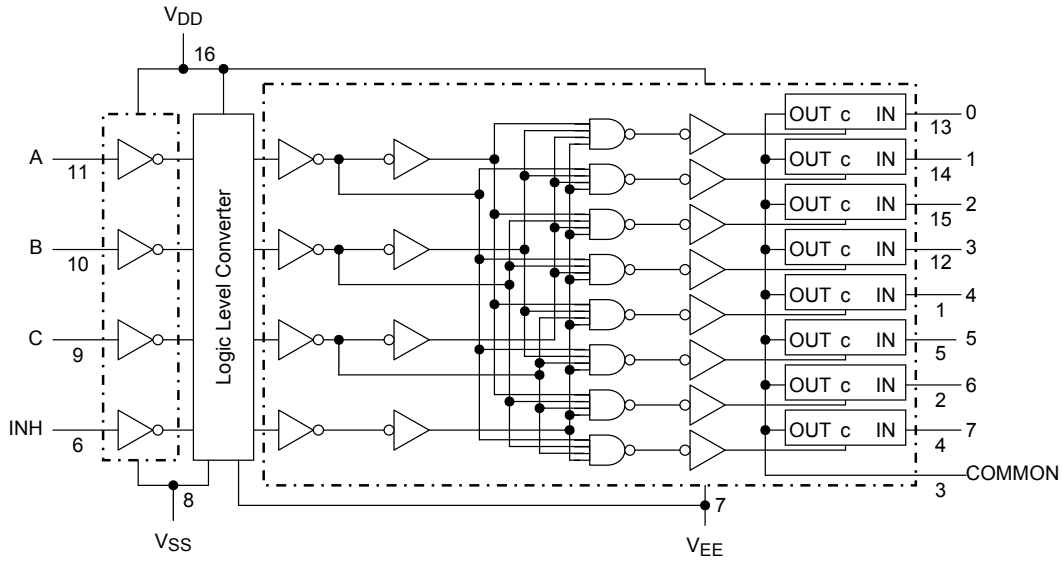

TC4052B

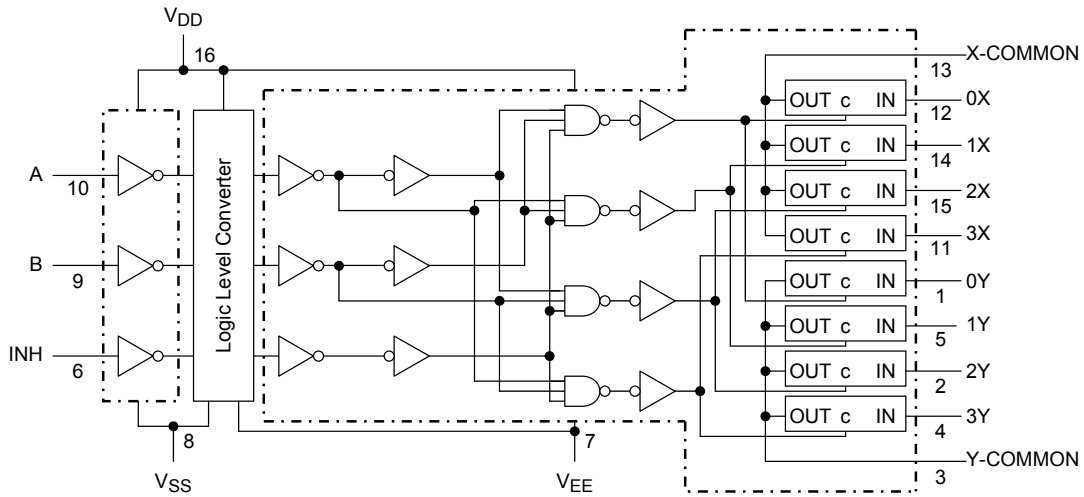

TC4053B

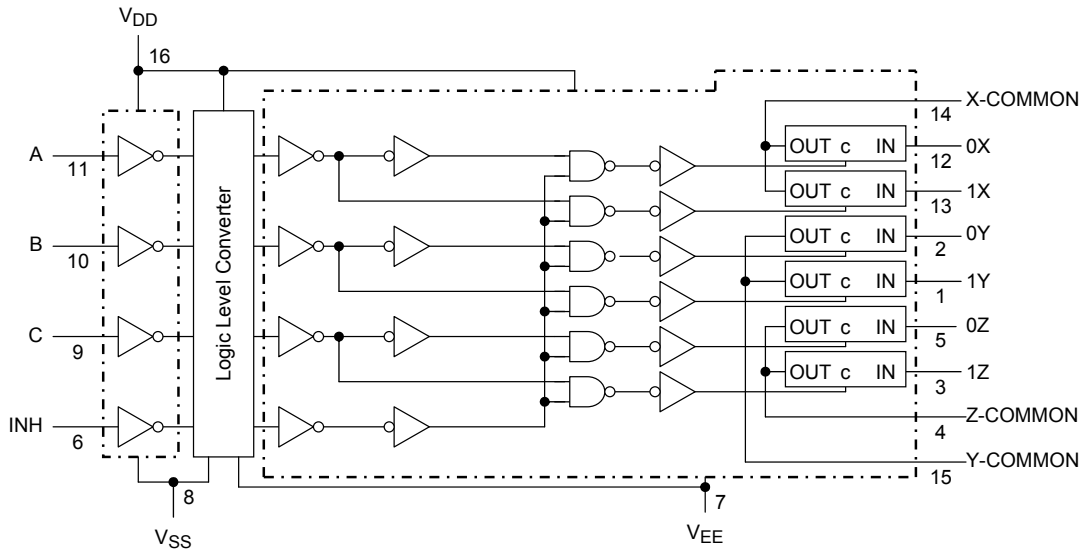

Truth Table

Control C	Impedance between IN-OUT (Note)
H	$0.5 \text{ to } 5 \times 10^2 \Omega$
L	$>10^9 \Omega$

Note: See electrical characteristics



Absolute Maximum Ratings (Note)

Characteristics	Symbol	Rating	Unit
DC supply voltage	$V_{DD}-V_{SS}$	-0.5 to 20	V
DC supply voltage	$V_{DD}-V_{EE}$	-0.5 to 20	V
Control input voltage	V_{CIN}	$V_{SS} - 0.5 \text{ to } V_{DD} + 0.5$	V
Switch I/O voltage	V_I/V_O	$V_{EE} - 0.5 \text{ to } V_{DD} + 0.5$	V
Control input current	I_{CIN}	± 10	mA
Potential difference across I/O during ON	V_I-V_O	-0.5 to 0.5	V
Power dissipation	P_D	300 (DIP)/180 (SOIC)	mW
Operating temperature range	T_{opr}	-40 to 85	$^{\circ}\text{C}$
Storage temperature range	T_{stg}	-65 to 150	$^{\circ}\text{C}$

Note: Exceeding any of the absolute maximum ratings, even briefly, lead to deterioration in IC performance or even destruction.

Using continuously under heavy loads (e.g. the application of high temperature/current/voltage and the significant change in temperature, etc.) may cause this product to decrease in the reliability significantly even if the operating conditions (i.e. operating temperature/current/voltage, etc.) are within the absolute maximum ratings and the operating ranges.

Please design the appropriate reliability upon reviewing the Toshiba Semiconductor Reliability Handbook ("Handling Precautions"/"Derating Concept and Methods") and individual reliability data (i.e. reliability test report and estimated failure rate, etc).

Operating Ranges (Note)

Characteristics	Symbol	Test Condition	Min	Typ.	Max	Unit
DC supply voltage	$V_{DD}-V_{SS}$	—	3	—	18	V
	$V_{DD}-V_{EE}$	—	3	—	18	
Control input voltage	V_{IN}	—	V_{SS}	—	V_{DD}	V
Input/output voltage	V_{IN}/V_{OUT}	—	V_{EE}	—	V_{DD}	V

Note: The operating ranges must be maintained to ensure the normal operation of the device.
Unused Control inputs must be tied to either V_{DD} or V_{SS} .

Static Electrical Characteristics

Characteristics	Symbol	Test Condition			-40°C		25°C			85°C		Unit	
		V_{SS} (V)	V_{EE} (V)	V_{DD} (V)	Min	Max	Min	Typ.	Max	Min	Max		
Control input high voltage	V_{IH}	$V_{IS} = V_{DD}$ thru 1 k Ω	$V_{EE} = V_{SS}$ $R_L = 1$ k Ω to V_{SS}	5	3.5	—	3.5	2.75	—	3.5	—	V	
				10	7.0	—	7.0	5.50	—	7.0	—		
				15	11.0	—	11.0	8.25	—	11.0	—		
Control input low voltage	V_{IL}		$I_{IS} < 2$ μ A on all OFF channels	5	—	1.5	—	2.25	1.5	—	1.5	V	
				10	—	3.0	—	4.5	3.0	—	3.0		
				15	—	4.0	—	6.75	4.0	—	4.0		
On-state resistance	R_{ON}	$0 \leq V_{IS} \leq V_{DD}$ $R_L = 10$ k Ω	0	0	5	—	850	—	240	950	—	1200	Ω
			0	0	10	—	210	—	110	250	—	300	
			0	0	15	—	140	—	80	160	—	200	
Δ On-state resistance between any 2 switches	$R_{ON\Delta}$	—	0	0	5	—	—	—	10	—	—	—	Ω
			0	0	10	—	—	—	6	—	—	—	
			0	0	15	—	—	—	4	—	—	—	
Input/output leakage current	I_{OFF}	$V_{IN} = 18$ V, $V_{OUT} = 0$ V $V_{IN} = 0$ V, $V_{OUT} = 18$ V	18	—	± 100	—	± 0.01	± 100	—	± 1000	—	± 1000	nA
			18	—	± 100	—	± 0.01	± 100	—	± 1000	—	± 1000	
Quiescent supply current	I_{DD}	$V_{IN} = V_{SS}, V_{DD}$	(Note)	5	—	5.0	—	0.005	5.0	—	150	μ A	
				10	—	10	—	0.010	10	—	300		
				15	—	20	—	0.015	20	—	600		
Input current	I_{IN}	$V_{IH} = 18$ V $V_{IL} = 0$ V	18	—	0.1	—	10^{-5}	0.1	—	1.0	μ A		
			18	—	-0.1	—	-10^{-5}	-0.1	—	-1.0			
Input capacitance	C_{IN}	—	—	—	—	—	—	5	7.5	—	—	pF	
Switch input capacitance	C_{IN}	—	—	—	—	—	—	10	—	—	—	pF	
Output capacitance	C_{OUT}	TC4051B	10	—	—	—	58	—	—	—	pF		
		TC4052B	10	—	—	—	30	—	—	—			
		TC4053B	10	—	—	—	17	—	—	—			
Feedthrough capacitance	$C_{IN-C-OUT}$	TC4051B	10	—	—	—	0.2	—	—	—	pF		
		TC4052B	10	—	—	—	0.2	—	—	—			
		TC4053B	10	—	—	—	0.2	—	—	—			

Note: All valid input combinations.

Dynamic Electrical Characteristics (Ta = 25°C, CL = 50 pF)

Characteristics	Symbol	Test Condition	Test Condition			Min	Typ.	Max	Unit
			VSS (V)	VEE (V)	VDD (V)				
Phase difference between input to output	ϕ_{I-O}	—	0	0	5	—	15	45	ns
			0	0	10	—	8	20	
			0	0	15	—	6	15	
Propagation delay time (A, B, C, -OUT)	t_{pZL} t_{pZH} t_{pLZ} t_{pHZ}	$R_L = 1\text{ k}\Omega$	0	0	5	—	170	550	ns
			0	0	10	—	90	240	
			0	0	15	—	70	160	
			0	-5	5	—	100	240	
			0	-7.5	7.5	—	80	160	
Propagation delay time (INH-OUT)	t_{pZL} t_{pZH}	$R_L = 1\text{ k}\Omega$	0	0	5	—	120	380	ns
			0	0	10	—	60	200	
			0	0	15	—	50	160	
			0	-5	5	—	80	200	
			0	-7.5	7.5	—	60	160	
Propagation delay time (INH-OUT)	t_{pLZ} t_{pHZ}	$R_L = 1\text{ k}\Omega$	0	0	5	—	170	450	ns
			0	0	10	—	90	210	
			0	0	15	—	70	160	
			0	-5	5	—	100	210	
			0	-7.5	7.5	—	80	160	
-3dB cutoff frequency TC4051B TC4052B TC4053B	f_{max} (I-O)	$R_L = 1\text{ k}\Omega$ (Note 1)	-5	-5	5	—	20	—	MHz
			-5	-5	5	—	30	—	
			-5	-5	5	—	40	—	
Total harmonic distortion	—	$R_L = 10\text{ k}\Omega$ $f = 1\text{ kHz}$ (Note 2)	-2.5	-2.5	2.5	—	0.15	—	%
			-5	-5	5	—	0.03	—	
			-7.5	-7.5	7.5	—	0.02	—	
-50dB feedthrough (switch off)	—	$R_L = 1\text{ k}\Omega$ (Note 3)	-5	-5	5	—	500	—	kHz
Crosstalk	—	$R_L = 1\text{ k}\Omega$ (Note 4)	-5	-5	5	—	1.5	—	MHz
Crosstalk (control-OUT)	—	$R_{IN} = 1\text{ k}\Omega$ $R_{OUT} = 10\text{ k}\Omega$ $C_L = 15\text{ pF}$	0	0	5	—	200	—	mV
			0	0	10	—	400	—	
			0	0	15	—	600	—	

Note 1: Sine wave of $\pm 2.5 V_{p-p}$ shall be used for V_{IS} and the frequency of $20 \log 10 \frac{V_{OS}}{V_{IS}} = -3\text{dB}$ shall be f_{max} .

Note 2: V_{IS} shall be sine wave of $\pm \left(\frac{V_{DD} - V_{EE}}{4} \right)$ p-p.

Note 3: Sine wave of $\pm 2.5 V_{p-p}$ shall be used for V_{IS} and the frequency of $20 \log 10 \frac{V_{OS}}{V_{IS}} = -50\text{dB}$ shall be feed-through.

Note 4: Sine wave of $\pm 2.5 V_{p-p}$ shall be used for V_{IS} and the frequency of $20 \log 10 \frac{V_{OS}}{V_{IS}} = -50\text{dB}$ shall be crosstalk.

Package Dimensions

DIP16-P-300-2.54A

Unit : mm

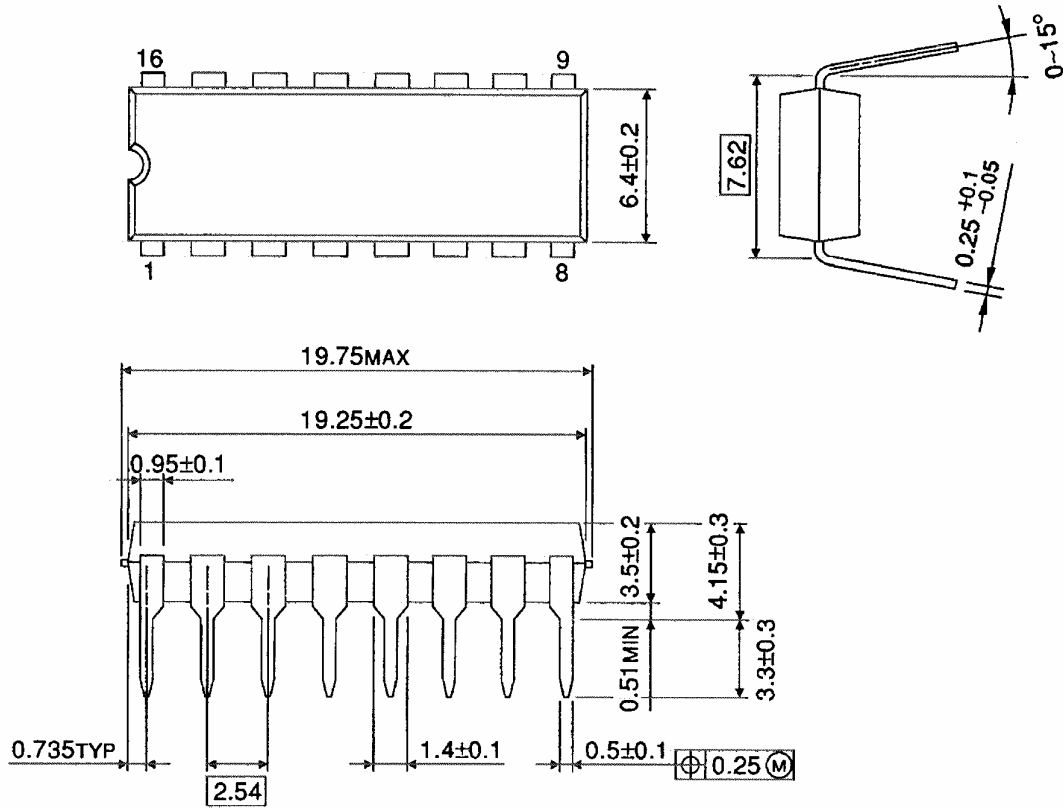

Weight: 1.00 g (typ.)

Package Dimensions

SOP16-P-300-1.27A

Unit: mm

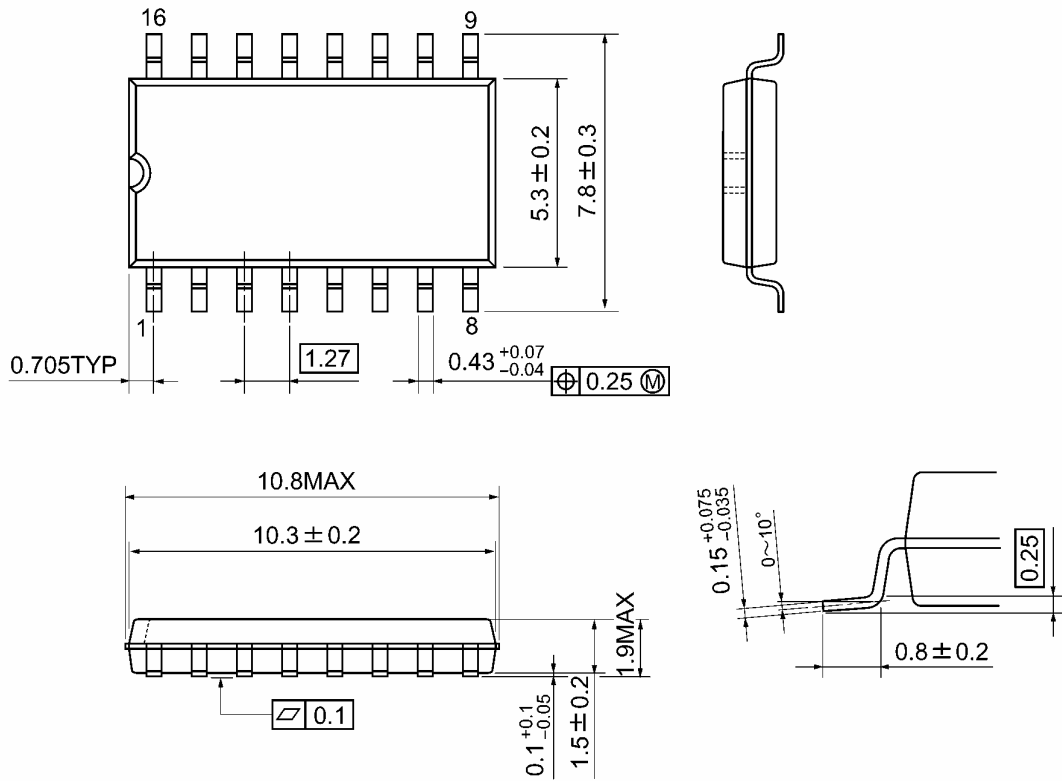

Weight: 0.18 g (typ.)

Package Dimensions (Note)

SOL16-P-150-1.27

Unit : mm

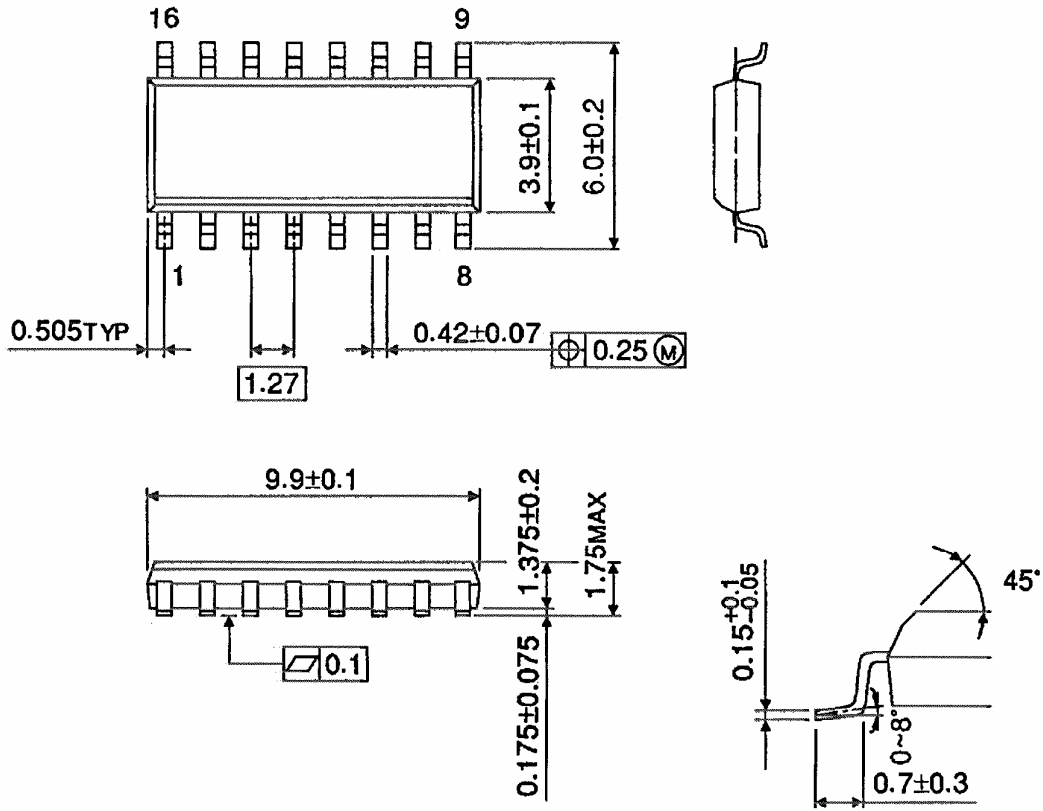

Note: This package is not available in Japan.

Weight: 0.13 g (typ.)

Package Dimensions

TSSOP16-P-0044-0.65A

Unit: mm

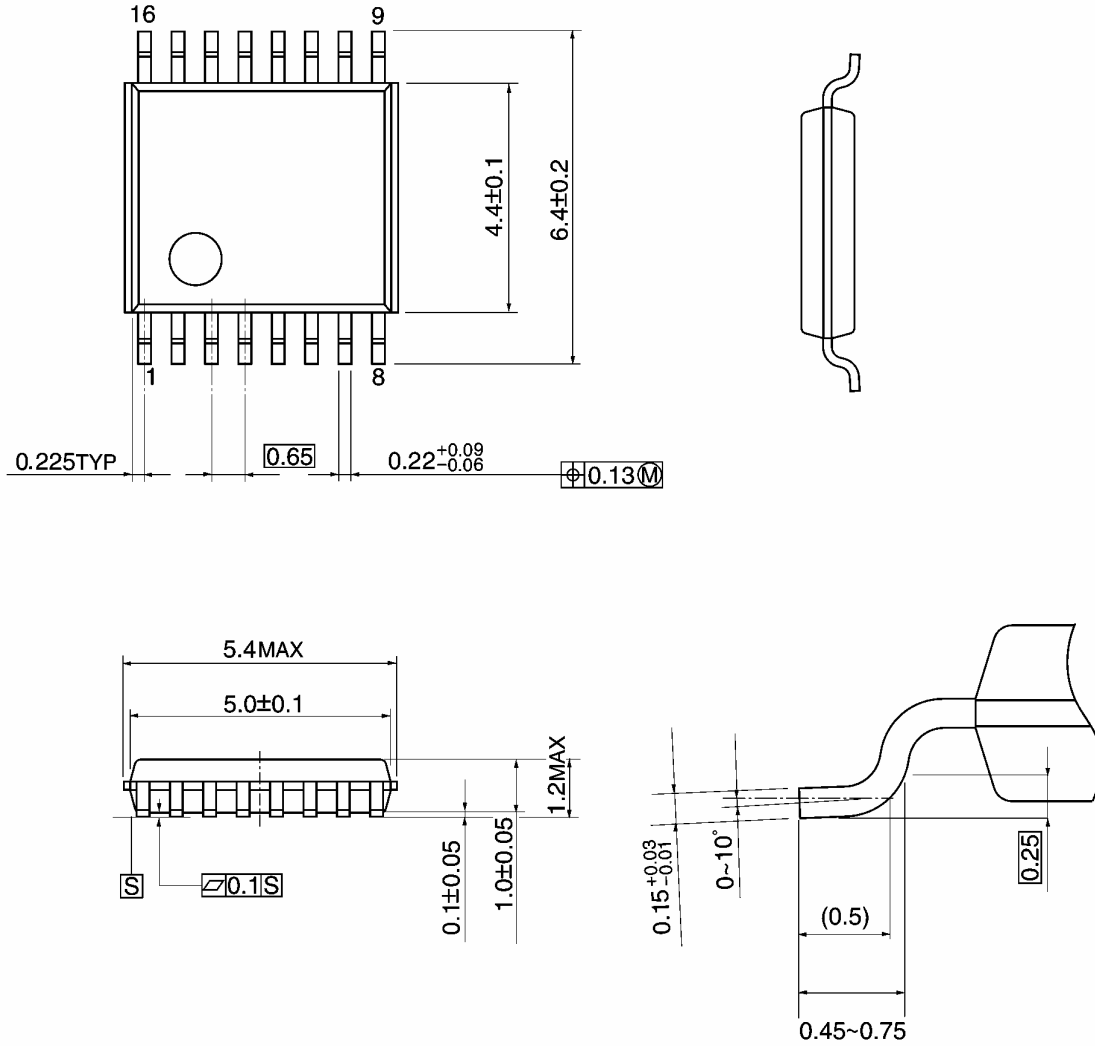

Weight: 0.06 g (typ.)

RESTRICTIONS ON PRODUCT USE

20070701-EN

- The information contained herein is subject to change without notice.
- TOSHIBA is continually working to improve the quality and reliability of its products. Nevertheless, semiconductor devices in general can malfunction or fail due to their inherent electrical sensitivity and vulnerability to physical stress. It is the responsibility of the buyer, when utilizing TOSHIBA products, to comply with the standards of safety in making a safe design for the entire system, and to avoid situations in which a malfunction or failure of such TOSHIBA products could cause loss of human life, bodily injury or damage to property.
In developing your designs, please ensure that TOSHIBA products are used within specified operating ranges as set forth in the most recent TOSHIBA products specifications. Also, please keep in mind the precautions and conditions set forth in the "Handling Guide for Semiconductor Devices," or "TOSHIBA Semiconductor Reliability Handbook" etc.
- The TOSHIBA products listed in this document are intended for usage in general electronics applications (computer, personal equipment, office equipment, measuring equipment, industrial robotics, domestic appliances, etc.). These TOSHIBA products are neither intended nor warranted for usage in equipment that requires extraordinarily high quality and/or reliability or a malfunction or failure of which may cause loss of human life or bodily injury ("Unintended Usage"). Unintended Usage include atomic energy control instruments, airplane or spaceship instruments, transportation instruments, traffic signal instruments, combustion control instruments, medical instruments, all types of safety devices, etc.. Unintended Usage of TOSHIBA products listed in his document shall be made at the customer's own risk.
- The products described in this document shall not be used or embedded to any downstream products of which manufacture, use and/or sale are prohibited under any applicable laws and regulations.
- Please contact your sales representative for product-by-product details in this document regarding RoHS compatibility. Please use these products in this document in compliance with all applicable laws and regulations that regulate the inclusion or use of controlled substances. Toshiba assumes no liability for damage or losses occurring as a result of noncompliance with applicable laws and regulations.