

TOSHIBA BIPOLAR LINEAR INTEGRATED CIRCUIT SILICON MONOLITHIC

TA8122AN, TA8122AF, TA8123AN, TA8123AF**3V AV / FM 1CHIP TUNER IC**

TA8122AN/AF and TA8123AN/AF are the AM/FM 1Chip Tuner ICs, which are designed for Portable Radios and 3V Headphone Radios.

FEATURES

- Built-in
 - FM F/E, AM/FM IF and FM ST DET
- AM Detector Coil, FM IFT and IF Coupling Condenser are not needed.
- For adopting Ceramic Discriminator and Ceramic Resonator, it is not necessary to adjust the FM Quad Detector Circuit and FM ST DET VCO Circuit.
- S curve characteristics of FM detection output in TA8122AN/AF and TA8123AN/AF are reverse to each other.
 - TA8122AN/AF : Reverse characteristic
 - TA8123AN/AF : Normal characteristic
- Compact Package
 - TA8122AN/23AN : Shrink DIP 24 pin (1.78mm pitch)
 - TA8122AF/23AF : Mini Flat Package 24 pin
- Operating Supply Voltage Range
 - $V_{CC} = 1.8 \sim 7.0V$ ($T_a = 25^\circ C$)

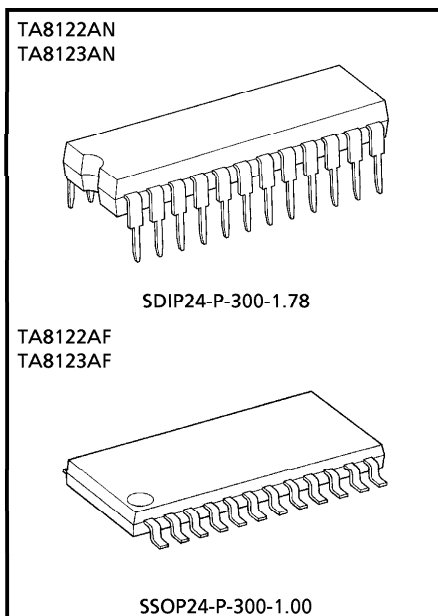

Weight
 SDIP24-P-300-1.78 : 1.2g (Typ.)
 SSOP24-P-300-1.00 : 0.31g (Typ.)

961001EBA2

- TOSHIBA is continually working to improve the quality and the reliability of its products. Nevertheless, semiconductor devices in general can malfunction or fail due to their inherent electrical sensitivity and vulnerability to physical stress. It is the responsibility of the buyer, when utilizing TOSHIBA products, to observe standards of safety, and to avoid situations in which a malfunction or failure of a TOSHIBA product could cause loss of human life, bodily injury or damage to property. In developing your designs, please ensure that TOSHIBA products are used within specified operating ranges as set forth in the most recent products specifications. Also, please keep in mind the precautions and conditions set forth in the TOSHIBA Semiconductor Reliability Handbook.
- The products described in this document are subject to foreign exchange and foreign trade control laws.
- The information contained herein is presented only as a guide for the applications of our products. No responsibility is assumed by TOSHIBA CORPORATION for any infringements of intellectual property or other rights of the third parties which may result from its use. No license is granted by implication or otherwise under any intellectual property or other rights of TOSHIBA CORPORATION or others.
- The information contained herein is subject to change without notice.

BLOCK DIAGRAM

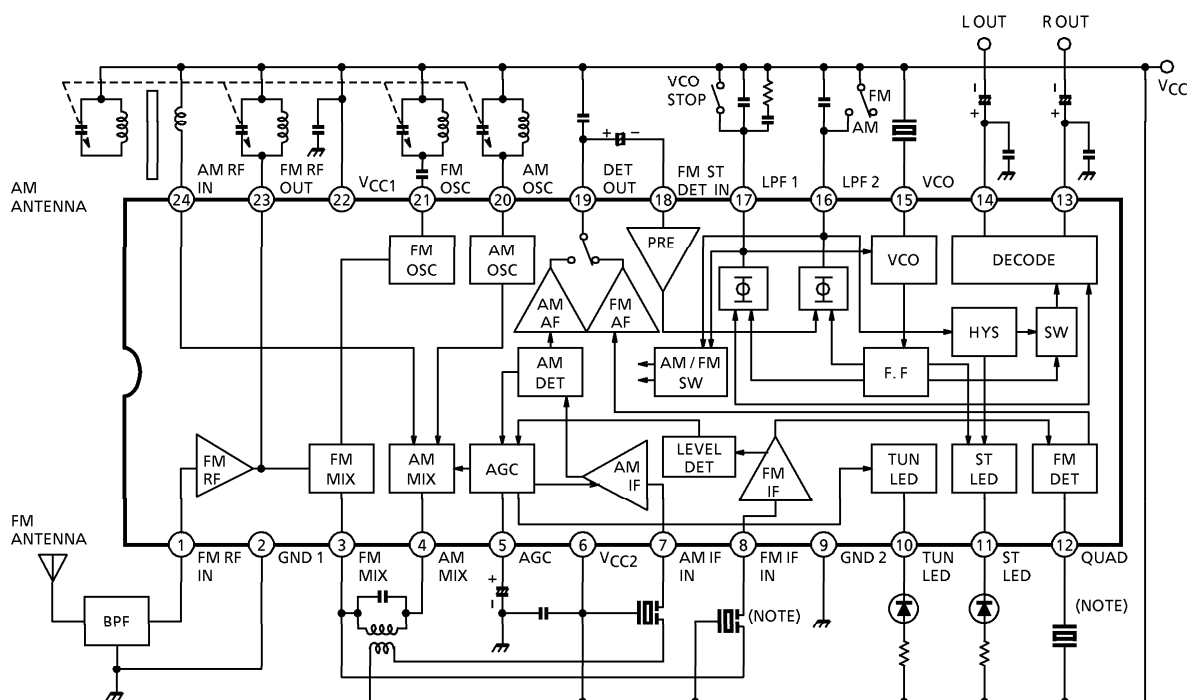

(Note)

We recommend the kit of the ceramic filter and the ceramic resonator which are shown in the table as below. It is necessary to meet the center frequency of the ceramic filter and the ceramic resonator, otherwise there are some cases that the characteristics get worse.

KIT NAME	COMBINATION			
	CERAMIC FILTER	Q'ty	CERAMIC RESONATOR	Q'ty
KMFC403-Z	SFE10.7MA5-Z	2	CDA10.7MG16-Z	1
KMFC411-Z	SFE10.7MA5-Z	1	CDA10.7MG16-Z	1
KMFC422-Z	SFE10.7MA2-Z	2	CDA10.7MG16-Z	1
KMFC435-Z	SFE10.7MA5L-Z	2	CDA10.7MG16-Z	1
KMFC445-Z	SFE10.7MA5L-Z	1	CDA10.7MG16-Z	1

MANUFACTURER : MURATA MFG. CO., LTD

EXPLANATION OF TERMINALS

PIN No.	CHARACTERISTIC	INTERNAL CIRCUIT	DC VOLTAGE (V) (AT NO SIGNAL)	
			AM	FM
1	FM-RF IN		0	0.7
2	GND1 (GND For RF Stage)	—	0	0
3	FM MIX		2.3	1.8
4	AM MIX		2.3	1.8
5	AGC (AM AGC)		0	0
6	V _{CC2} (V _{CC} For IF/MPX Stage)	—	3.0	3.0

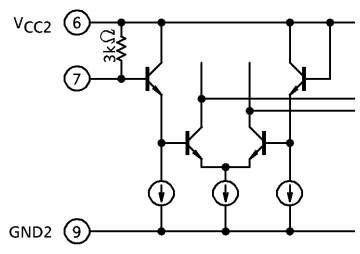
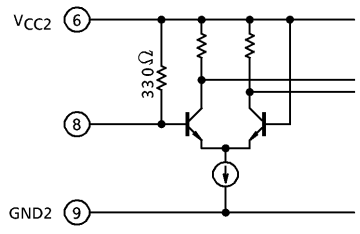
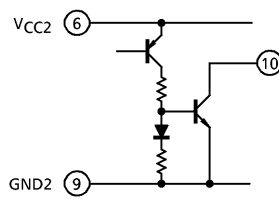
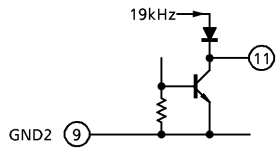
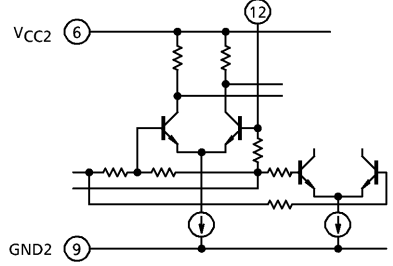
PIN No.	CHARACTERISTIC	INTERNAL CIRCUIT	DC VOLTAGE (V) (AT NO SIGNAL)	
			AM	FM
7	AM IF IN		3.0	3.0
8	FM IF IN		3.0	3.0
9	GND2 (GND For IF / MPX Stage)	—	0	0
10	TUN LED (Tuning LED)		—	—
11	ST LED (Stereo LED)		—	—
12	QUAD (FM QUAD. Detector)		2.4	2.1

PIN No.	CHARACTERISTIC	INTERNAL CIRCUIT	DC VOLTAGE (V) (AT NO SIGNAL)	
			AM	FM
13 14	R-OUT (R-ch Output) L-OUT (L-ch Output)		1.0	1.0
15	VCO		2.5	2.5 (VCO stop mode)
16	LPF2 <ul style="list-style-type: none"> ● LPF Terminal For Synchronous Detector ● Bias Terminal For AM / FM SW Circuit $V_{16} = V_{CC} \rightarrow \text{AM}$ $V_{16} = \text{Open} \rightarrow \text{FM}$		3.0	2.2 (VCO stop mode) 2.7
17	LPF1 LPF Terminal For Phase Detector VCO Stop Terminal $V_{17} = V_{CC} \rightarrow \text{VCO Stop}$		2.7	2.2
18	FM ST DET IN		0.7	0.7

PIN No.	CHARACTERISTIC	INTERNAL CIRCUIT	DC VOLTAGE (V) (AT NO SIGNAL)	
			AM	FM
19	DET OUT	<p> (A) LOW → FM, HIGH → AM (B) LOW → AM, HIGH → FM </p>	1.5	1.2
20	AM OSC		3.0	3.0
21	FM OSC		3.0	3.0
22	VCC1 (VCC For RF Stage)	—	3.0	3.0
23	FM RF OUT	cf. pin①	3.0	3.0
24	AM RF IN		3.0	3.0

MAXIMUM RATINGS (Ta = 25°C)

CHARACTERISTIC		SYMBOL	RATING	UNIT
Supply Voltage		V _{CC}	8	V
LED Current		I _{LED}	10	mA
LED Voltage		V _{LED}	8	V
Power	TA8122AN/23AN	P _D (Note)	1200	mW
Dissipation	TA8122AF/23AF		400	
Operating Temperature		T _{opr}	-25~75	°C
Storage Temperature		T _{stg}	-55~150	°C

Note : Derated above 25°C in the proportion of 9.6mW/°C for TA8122AN/23AN and of 3.2mW/°C for TA8122AF/23AF

ELECTRICAL CHARACTERISTICS

Unless otherwise specified,

Ta = 25°C, VCC = 3V, F/E : f = 83MHz, fm = 1kHz
 FM IF : f = 10.7MHz, Δf = ± 22.5kHz, fm = 1kHz
 AM : f = 1MHz, MOD = 30%, fm = 1kHz
 FM ST DET : fm = 1kHz

CHARACTERISTIC		SYMBOL	TEST CIR-CUIT	TEST CONDITION	MIN.	TYP.	MAX.	UNIT
Supply Current		I _{CC} (FM)	1	V _{in} = 0, FM mode	—	14.0	18.5	mA
		I _{CC} (AM)	1	V _{in} = 0, AM mode	—	6.0	8.3	
F/E	Input Limiting Voltage	V _{in} (lim.)	1	- 3dB limiting	—	14.0	—	dB μ V EMF
	Local OSC Voltage	V _{OSC}	2	f _{OSC} = 72.3MHz	70	105	140	mV _{rms}
	Input Limiting Voltage IF	V _{in} (lim.) IF	1	- 3dB limiting	39	44	49	dB μ V EMF
FM IN	Recovered Output Voltage	V _{OD}	1	V _{in} = 80dB μ V EMF	55	80	110	mV _{rms}
	Signal To Noise Ratio	S/N	1	V _{in} = 80dB μ V EMF	—	70	—	dB
	Total Harmonic Distortion	THD	1	V _{in} = 80dB μ V EMF	—	0.4	—	%
	AM Rejection Ratio	AMR	1	V _{in} = 80dB μ V EMF	—	50	—	dB
	LED ON Sensitivity	V _L	1	I _L = 1mA	43	48	53	dB μ V EMF
AM	Gain	G _V	1	V _{in} = 23dB μ V EMF	20	40	80	mV _{rms}
	Recovered Output Voltage	V _{OD}	1	V _{in} = 60dB μ V EMF	50	60	100	mV _{rms}
	Signal To Noise Ratio	S/N	1	V _{in} = 60dB μ V EMF	—	44	—	dB
	Total Harmonic Distortion	THD	1	V _{in} = 60dB μ V EMF	—	1.0	—	%
	LED ON Sensitivity	V _L	1	I _L = 1mA	19	24	29	dB μ V EMF
Pin ^⑨ Output Resistance		R ₁₉	1	FM mode	—	0.75	—	k Ω
				AM mode	—	12.5	—	

CHARACTERISTIC		SYMBOL	TEST CIR-CUIT	TEST CONDITION	MIN.	TYP.	MAX.	UNIT	
FM ST DET	Input Resistance	R_{IN}	—	—	—	24	—	k Ω	
	Output Resistance	R_{OUT}	—	—	—	5	—		
	Max. Composite Signal Input Voltage	V_{in} (MAX.) STEREO	1	L + R = 90%, P = 10% $f_m = 1\text{kHz}$, THD = 3%	—	350	—	mV _{rms}	
	Separation	Sep.	1	L + R = 135mV _{rms} P = 15mV _{rms}	$f_m = 100\text{Hz}$	—	42	—	dB
					$f_m = 1\text{kHz}$	35	42	—	
					$f_m = 10\text{kHz}$	—	42	—	
	Total Harmonic Distortion	Monaural	THD (MONAURAL)	1	$V_{in} = 150\text{mV}_{rms}$	—	0.2	—	%
		Stereo	THD (STEREO)		L + R = 135mV _{rms} , P = 15mV _{rms}	—	0.2	—	
	Voltage Gain		G_V (FM ST DET)	1	$V_{in} = 150\text{mV}_{rms}$	-5	-3	-1	dB
	Channel Balance		C.B.	1	$V_{in} = 150\text{mV}_{rms}$	-2	0	2	
	Stereo LED Sensitivity	ON	V_L (ON)	1	Pilot Input	—	8	15	mV _{rms}
		OFF	V_L (OFF)			2	6	—	
	Stereo LED Hysteresis		V_H	1	To LED turn off from LED turn on	—	2	—	mV _{rms}
Capture Range		C.R.	1	P = 15mV _{rms}	—	1.3	—	%	
Signal To Noise Ratio		S/N	1	$V_{in} = 150\text{mV}_{rms}$	—	70	—	dB	

TEST CIRCUIT 2

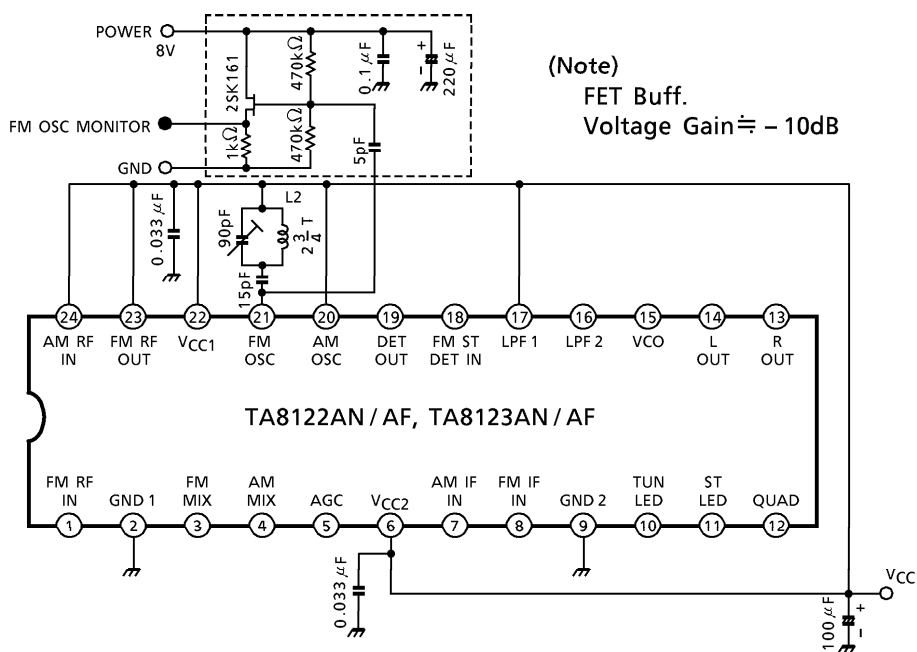

COIL DATA

COIL No.	TEST FREQ.	L (μH)	C ₀ (pF)	Q ₀	TURNS					WIRE (mm φ)	REFERENCE
					1-2	2-3	1-3	1-4	4-6		
L ₁ FM RF	100MHz	—	—	100	—	—	—	2 $\frac{1}{2}$	—	0.5UEW	Ⓢ 53T-037-202
L ₂ FM OSC	100MHz	—	—	100	—	—	2 $\frac{3}{4}$	—	—	0.5UEW	Ⓢ 0258-244
T ₁ AM OSC	796kHz	288	—	115	13	73	—	—	—	0.08UEW	Ⓢ 4147-1356-038
T ₂ AM IFT	455kHz	—	180	120	—	—	180	—	15	0.08UEW	Ⓢ 2150-2162-165

Ⓢ : SUMIDA ELECTRIC CO., LED.

L₁ : FM RF

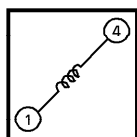

L₂ : FM OSC

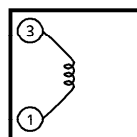

T₁ : AM OSC

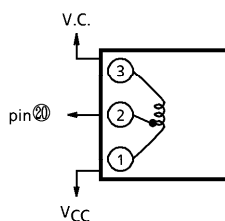

T₂ : AM IFT

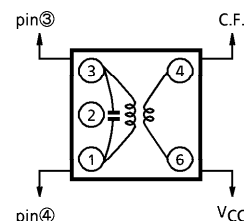

FM DETECTION CIRCUIT

For the FM detection circuit, detection coil is able to use instead of ceramic discriminator.

Recommended circuit and recommended coil are as follows.

In this case, please take care that V_{in} (lim.) falls a little.

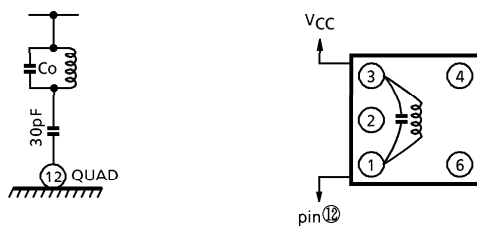

TEST FREQUENCY	C_o (pF)	Q_o	TURNS				WIRE (mm ϕ)	REF
			1-2	2-3	1-3	4-6		
10.7MHz	100	100	—	—	12	—	0.12UEW	SUMIDA ELECTRIC CO., LTD 2153-4095-189 or Equivalent

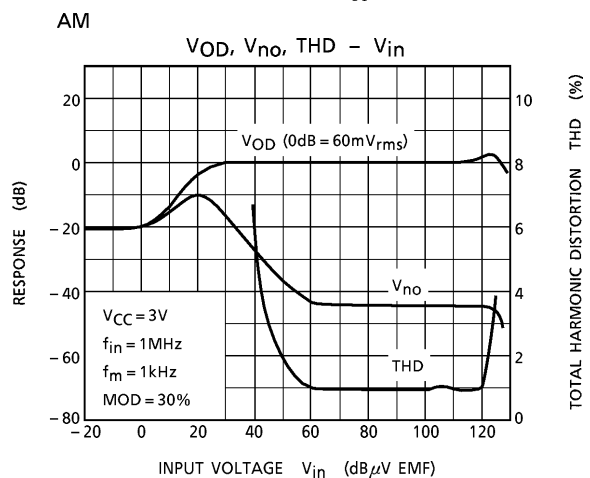
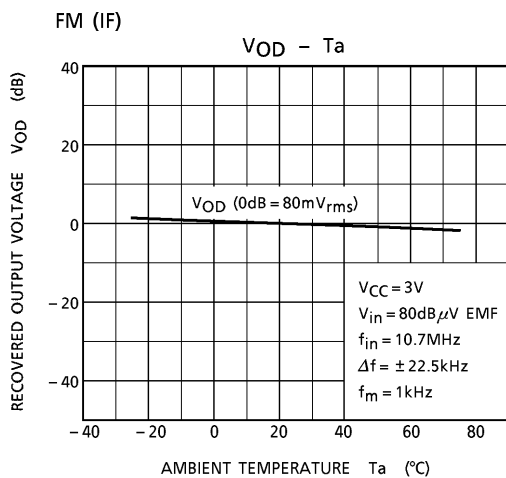
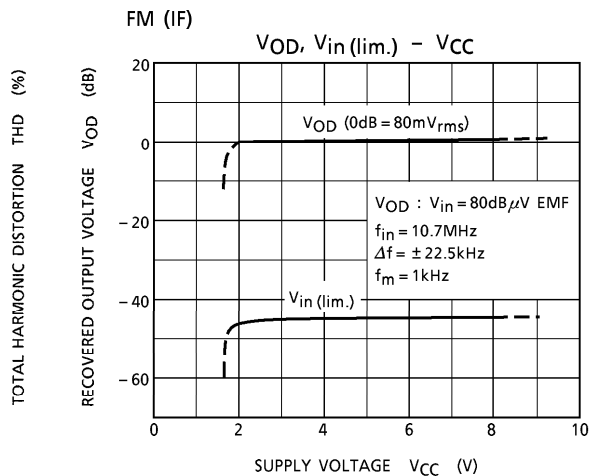
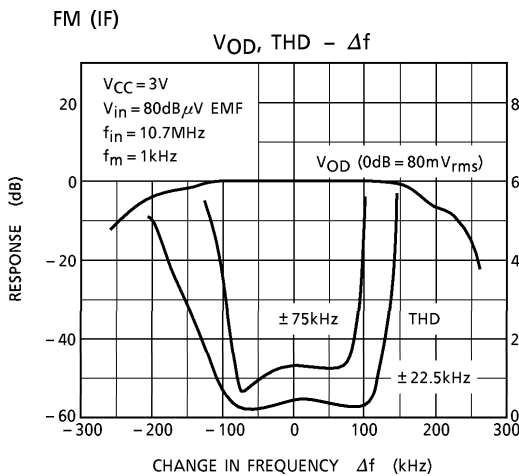
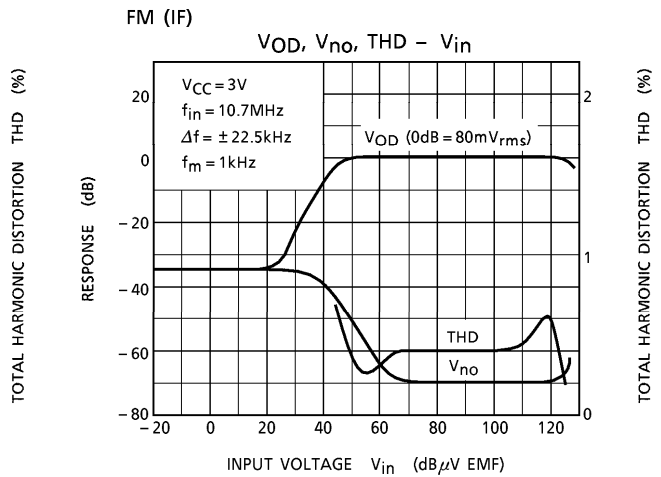
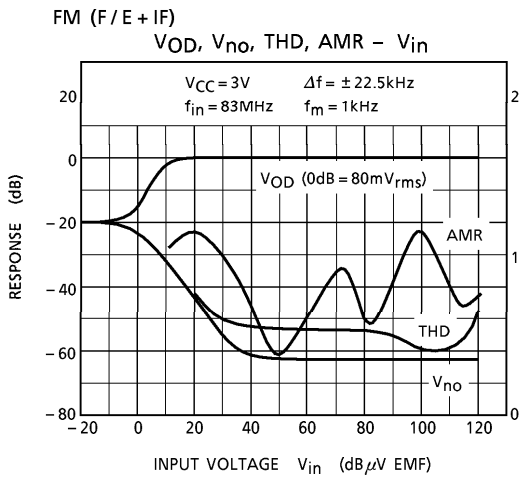

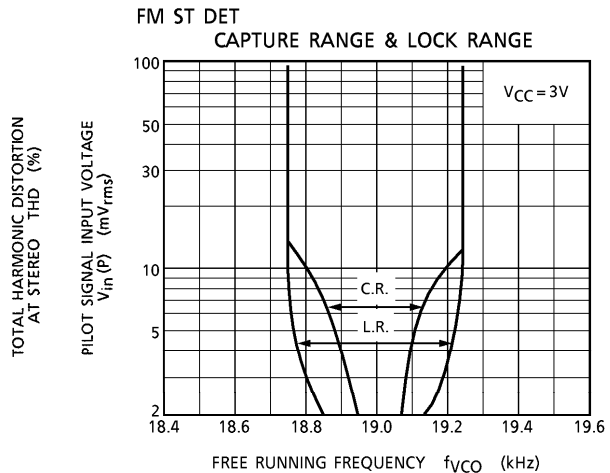
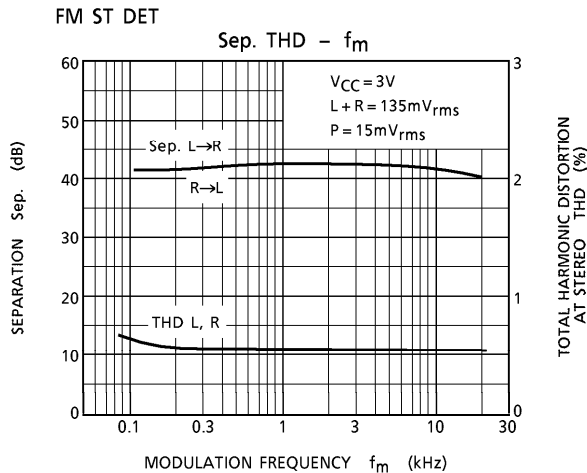
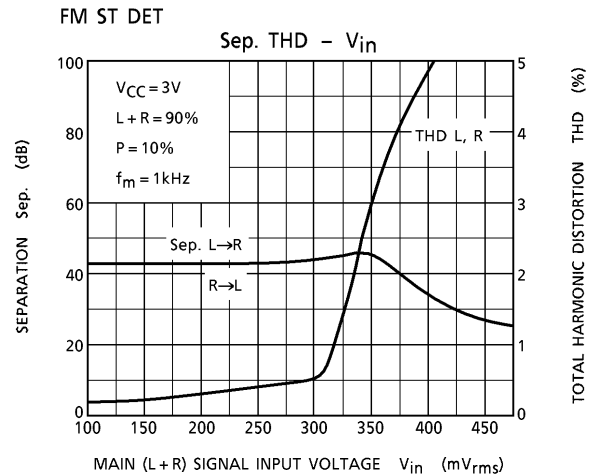
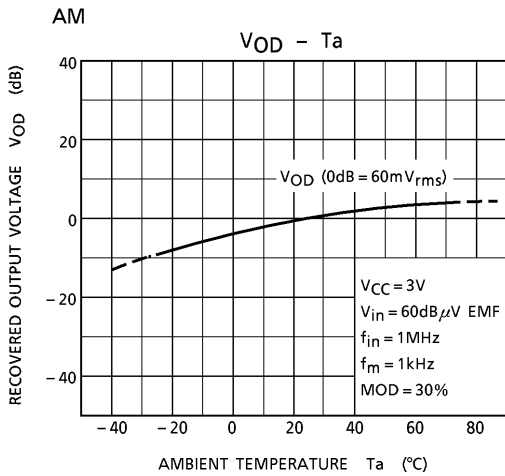
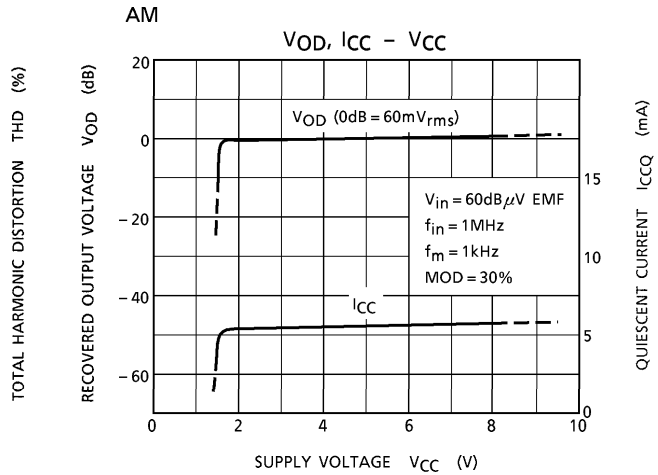
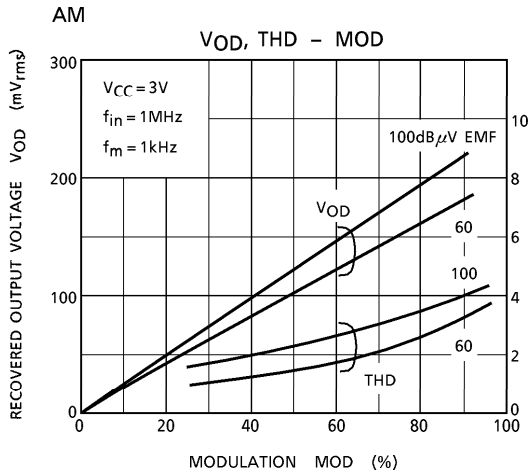

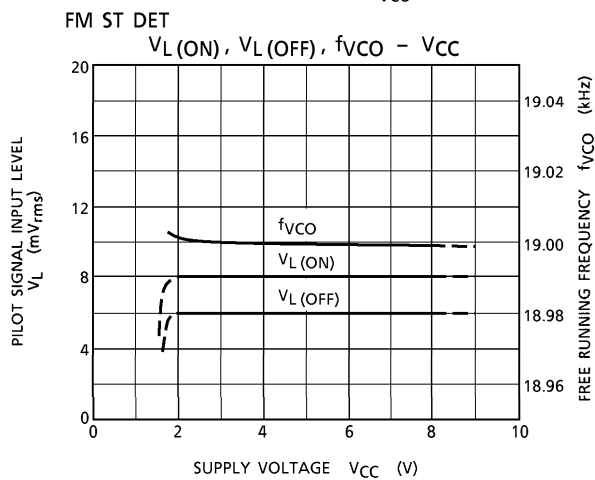
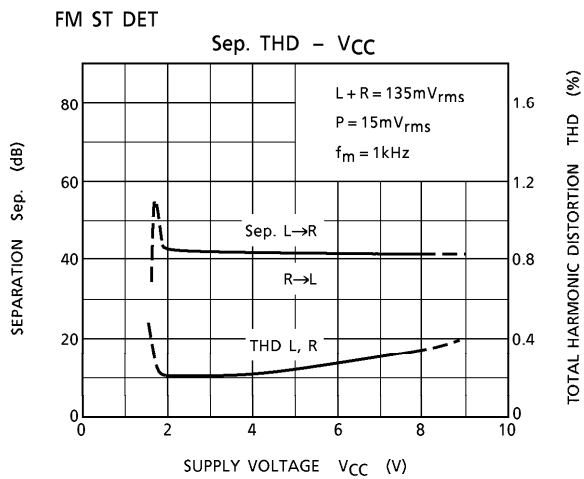
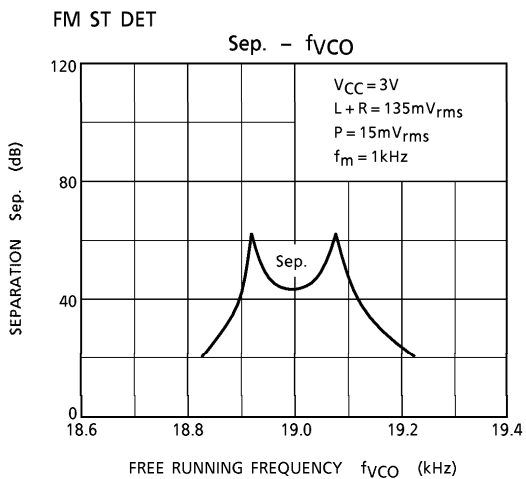

OUTLINE DRAWING
SDIP24-P-300-1.78

Unit : mm

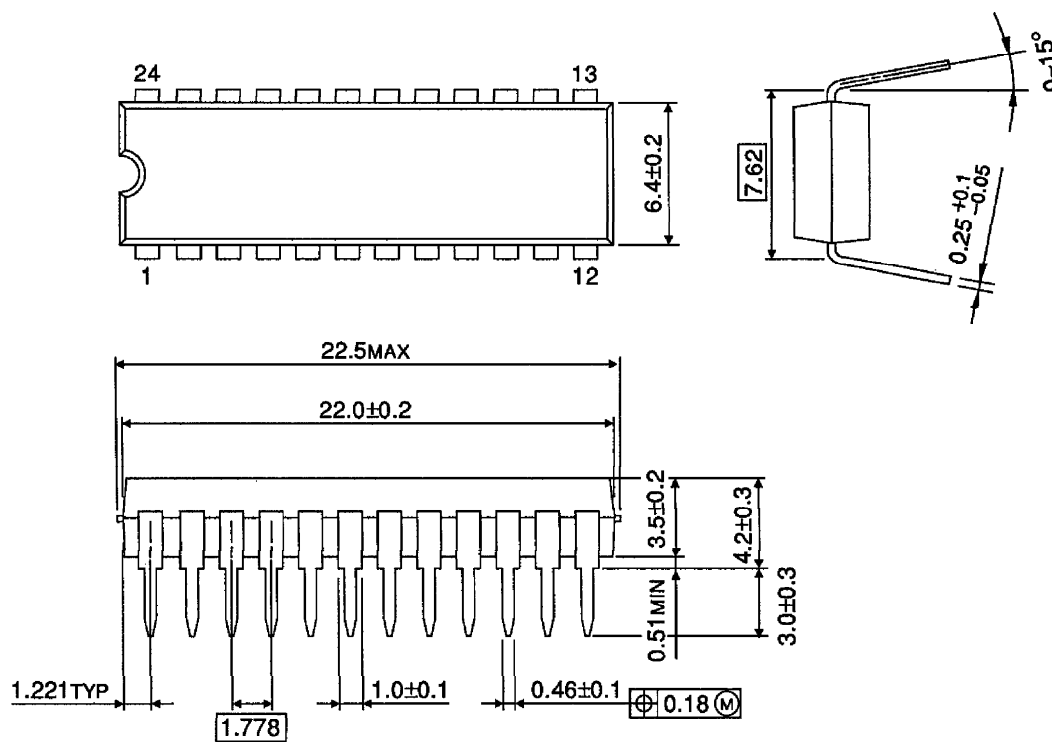

Weight : 1.2g (Typ.)

OUTLINE DRAWING
SSOP24-P-300-1.00

Unit : mm

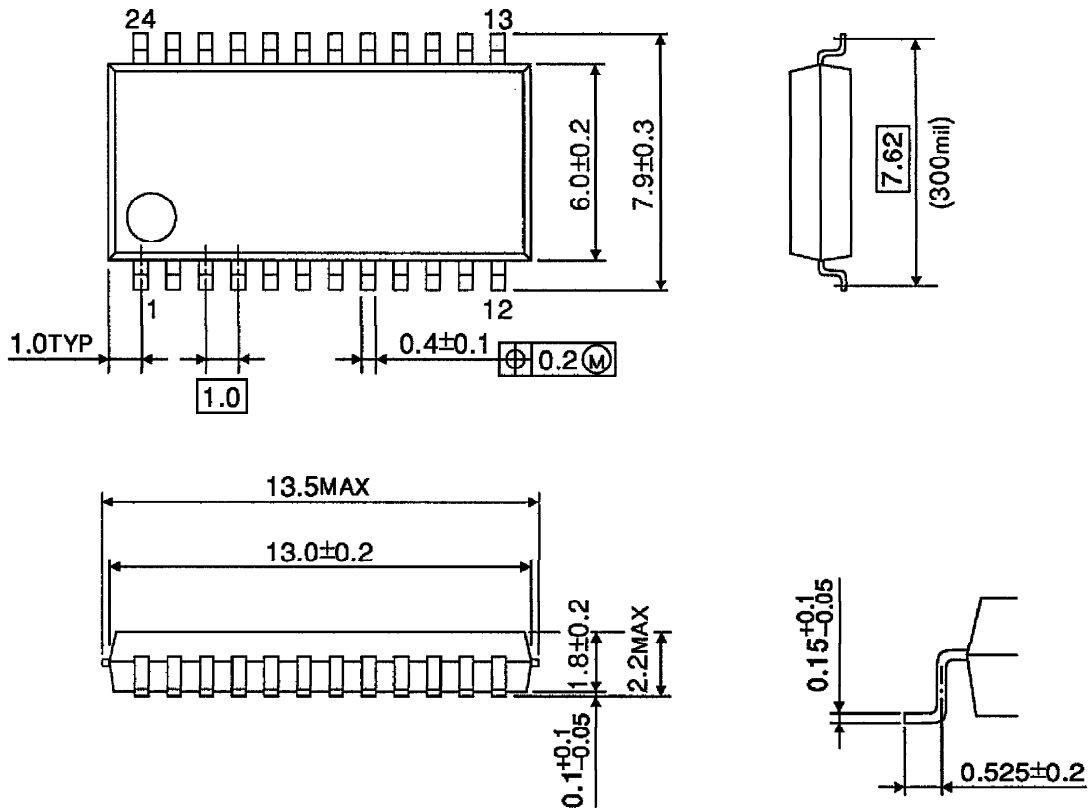

Weight : 0.31g (Typ.)