

AN6426NK

Hands-free Speech Network IC

■ Overview

The AN6426NK incorporates both speech network and hands-free functions. Its well designed block configuration allows realization of a hands-free telephone with a minimal number of components.

■ Features

- Incorporates all the functions required of a hands-free telephone.
- Incorporates all the functions required of a handset.
- Complies with AC and DC impedance requirements.
- Provides a wide dynamic range.
- A noise detecting circuit prevents inadvertent transmission.
- Operation on an external power supply is available.
- Each mode can be easily controlled.
- A built-in loudspeaker amplifier can operated either on line voltage or an external power supply.

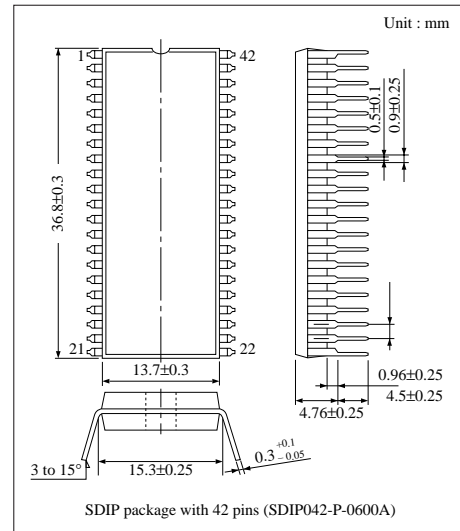

■ Block Diagram

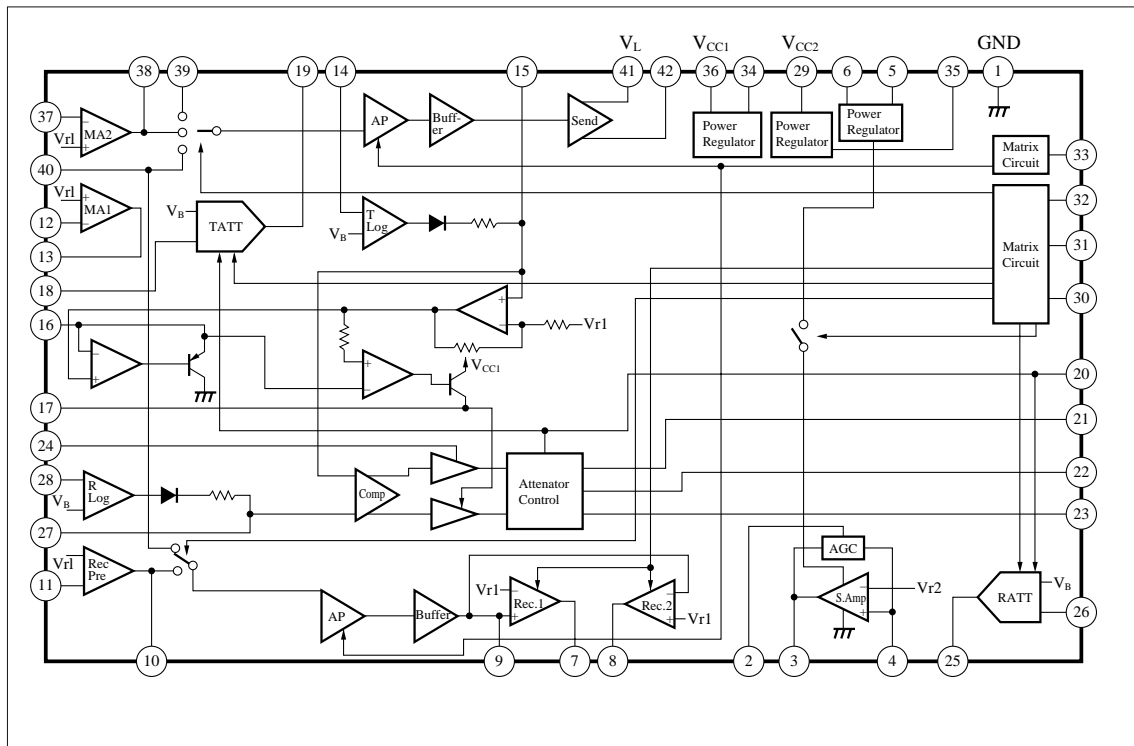

■ Pin Descriptions

Pin No.	Symbol	Description	Pin No.	Symbol	Description
1	GND	Ground	22	AC	Att. control
2	AGC	Loudspeaker amp. time constant	23	RAC	Receiver att. control
3	SAO	Loudspeaker amp. output	24	RVR	To receiver rheostat
4	SAI	Loudspeaker amp. input	25	RAO	Receiver att. output
5	Vr2	Reference voltage (2)	26	RAI	Receiver att. input
6	VPO	Loudspeaker amp. power supply	27	RLO	Receiver LOG amp. output
7	RO1	Receiver output (1)	28	RLI	Receiver LOG amp. input
8	RO2	Receiver output (2)	29	V _{CC2}	Supply voltage (2)
9	RBO	Receiver buffer output	30	Mute (R)	Receiver mute
10	RPO	Receiver preamp. output	31	HSu/SPu	HS/HF switching
11	RPI	Receiver preamp. input	32	Mute (S)	Transmitter mute
12	MAI1	MIC amp. input (1)	33	APC	Auto. PAD control
13	MAO1	MIC amp. output (1)	34	Vr1	Reference voltage (1)
14	TL1	Transmitter LOG amp. input	35	VB	Reference voltage
15	TLO	Transmitter LOG amp. output	36	VCC	Supply voltage (1)
16	ND1	Noise detection time constant (1)	37	MAO2	MIC amp. input (2)
17	ND2	Noise detection time constant (2)	38	MAO2	MIC amp. output (2)
18	TAI	Transmitter att. input	39	TSI	Transmitter signal input
19	TAO	Transmitter att. output	40	MF1 MF	MF signal input
20	ATC	Att. timing control	41	S0	Transmitter output
21	TAC	Transmitter att. control	42	VL	Line voltage

■ Absolute Maximum Ratings (Ta=25°C)

Parameter	Symbol	Rating	Unit
Supply voltage	V _L	14.4	V
Supply current	I _L	120	mA
Power dissipation (Ta = 60°C)	P _D	1700	mW
Operating ambient temperature	T _{opr}	-20 to + 60	°C
Storage temperature	T _{stg}	-55 to +150	°C

Note) The IC must be used under the condition $P_D > V_{CC} \times I_{CC}$.

■ Recommended Operating Range (Ta=25°C)

Parameter	Symbol	Range
Operating supply voltage range	V _L	3V to 12V

■ Electrical Characteristics (Ta=25°C)

Parameter	Symbol	Condition	min	typ	max	Unit		
Power Supply								
DC line voltage (1)	V _{L(1)}	Voltage at Pin42 with I _L =20mA	3.6	4.2	5.2	V		
DC line voltage (2)	V _{L(2)}	Voltage at Pin42 with I _L =120mA	9.0	11.0	12.0	V		
Int. supply voltage (1)	V _{CC(1)}	Voltage at Pin36 with I _L =20mA	1.8	2.3	2.8	V		
Int. supply voltage (2)	V _{CC(2)}	Voltage at Pin36 with I _L =120mA	6.0	7.0	9.0	V		
Int. regulated voltage (1)	V _{B(1)}	Voltage at Pin35 with I _L =20mA	0.95	1.10	1.35	V		
Int. regulated voltage (2)	V _{B(2)}	Voltage at Pin35 with I _L =120mA	1.10	1.20	1.45	V		
HS_U Receiver								
		input pin	output pin					
Rec. gain	G _R	11	7, 8	n _i =-60dBm	36	39	42	dB
Max. rec. level	V _R	11	7, 8	n _o =4dBm	4	7	10	dBm
MF rec. gain	G _{MR}	40	7, 8	f _i =1kHz, n _i =-25dBm	3	6	9	dB
MF max. rec. level	V _{MR}	40	7, 8	f _i =1kHz, n _o =5dBm	5	8	11	dBm
AP (R) characteristics	DG _R	11	7, 8	Gain difference with n _i =-60dBm as I _L changes between 30 and 80mA	-8	-6	-4	dB
HS_U Transmitter								
Trans. gain	G _S	37	42	n _i =-25dBm	26	29	32	dB
Max. trans. level	V _S	37	42	n _o =2.5dBm	2.5	5.5	8.5	dBm
MF trans. gain	G _{MS}	40	42	f _i =1kHz, n _i =-25dBm	22	25	28	dB
MF max. trans. level	V _{MS}	40	42	f _i =1kHz, n _o =1dBm	1	4	7	dBm
AP (S) characteristics	DG _S	37	42	Gain difference with n _i =-25dBm as I _L changes between 30 and 80mA	-6	-4	0	dB
SP_U Receiver								
Att. rec. gain	G _{ARR}	26	25	n _i =-20dBm	-6.5	-3.5	-0.5	dB
Att. trans. gain	G _{ART}	26	25	n _i =-20dBm, I ₂₀ =14μA T12-T11 Value	-38	-33	-28	dB
Loudspeaker amp. (1)	V _{OSP(1)}	4	3	V _{PO} =3V, THD=5%	-10	-5	—	dBm
Loudspeaker amp. (2)	V _{OSP(2)}	4	3	V _{PO} =5V, THD=5%	-4	1	—	dBm
Loudspeaker amp. (3)	V _{OSP(3)}	4	3	V _{PO} =7V, THD=5%	0	4	—	dBm
Rheostat characteristics (1)	V _V	26	25	V ₂₄ =V ₃₅ , n _i =-20dBm, I _L =60mA	-28	-25	-22	dBm

■ Electrical Characteristics (cont.) (Ta=25°C)

Parameter	Symbol	Condition		min	typ	max	Unit		
Rheostat characteristics (2)	DGV	26	25	V ₂₄ =0V, n _i =-20dBm, I _L =60mA		-27	-22	-17	dBm
LOG amp. linearity	L _R	I _L =60mA, I _i =-1μA to -300μA		40	50	—	—	—	dB
SP _U Transmitter		Input pins	Output pins						
MIC amp. gain	G _{MAI}	12	13	n _i =-60dBm I _L =60mA		32	35	38	dB
MIC amp. max. output	V _{MAI}	12	13	I _L =60mA THD=5%		1	4	7	dBm
Trans. gain	G _{TS}	39	42	n _i =-25dBm I _L =60mA		17	20	23	dB
Max. trans. level	V _{TS}	39	42	I _L =60mA THD=10%		4	7	10	dBm
Att. trans. gain	G _{ATT}	18	19	n _i =-20dBm I _L =60mA		-2.5	0.5	3.5	dB
Att. rec. gain	DG _{ATR}	18	19	n _i =-20dBm I _L =60mA		-34	-29	-24	dB
Idling	V _{Id}	18	19	n _i =-20dBm I _L =60mA		-18	-15	-12	dB
LOG amp. linearity	L _T	I _L =60mA I _i =-1μA to -300μA		40	50	—	—	—	dB

Note) Unless otherwise specified, f_i=1kHz, I_L=30mA(HS_U), 60mA (SP_U).

■ Application Circuit

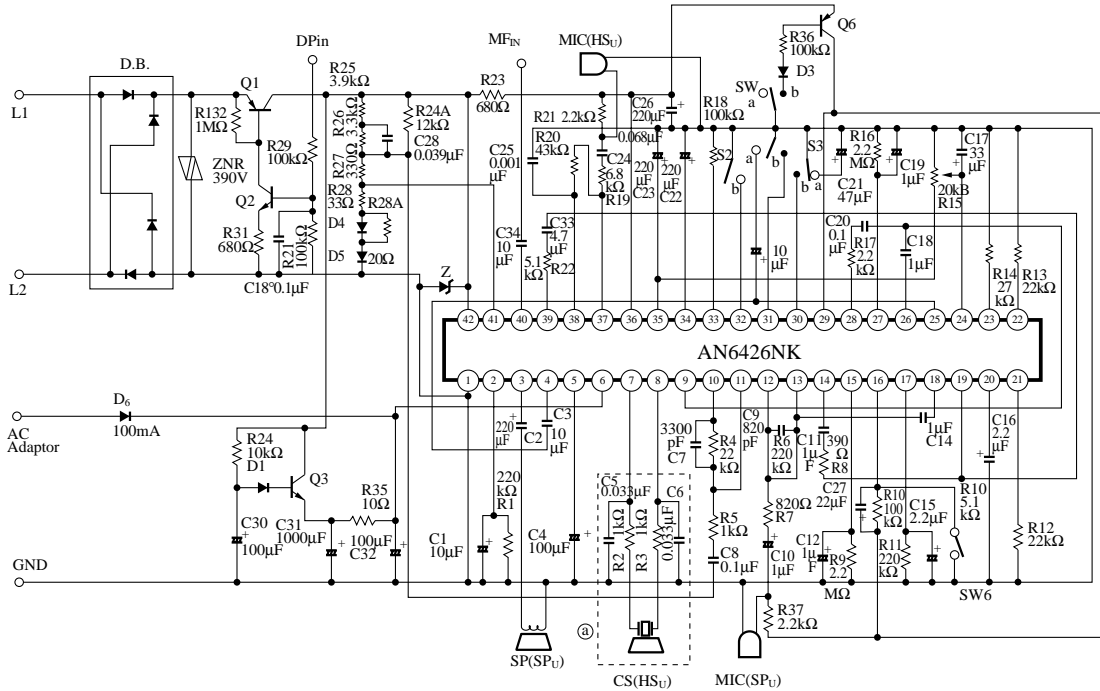

Note) The circuit ① applies when a ceramic receiver is used.
When a dynamic receiver is used, the following circuits apply.

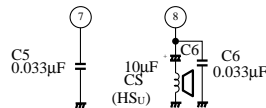

■ Pin Descriptions

1. Hand Set Communications Block (HSu)

[Transmitter System]

◇Microphone amplifier

Input : pin3 (minus input), Output : Pin38 (collector output)

The gain and frequency characteristics are determined by the external resistors R19 (6.8kΩ)and R20 (43kΩ), and capacitors C24 (0.068μF)and C25 (1,000pF).

R21 (2.2kΩ)is a resistor for the power supply for ECM.

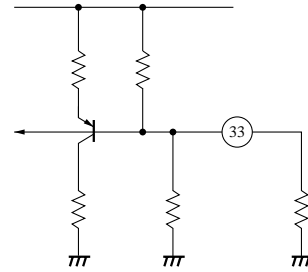
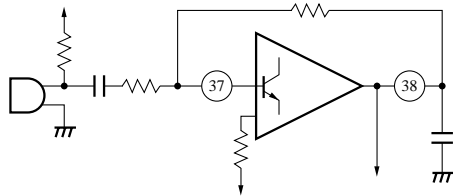

[Receiver System]

◇Receiver preamplifier

Input : Pin11(minus input), Output : Pin10 (collector output)

The gain and frequency characteristics are determined by the external resistors R5 (1kΩ)and R4 (22kΩ), and capacitors C8 (0.1μF)and C7 (3,300pF)

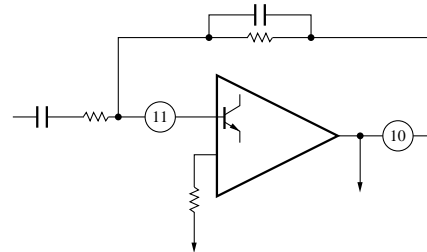

◇Transmitter selector switch

Input : Pin39 (speech), Pin40 (MF, holding tone)

The switch changes over transmitter input for hand set communications, transmitter input for hand-free communications, and MF (Multi Frequency) input. The input impedance at the Pin39 is 3.9kΩ and DC is VR (Pin34)

C33 (4.7μF) is a DC preventive capacitor. R22 (33kΩ) is to adjust the input to the log amplifier, which is to detect the transmission level. It attenuates the amplifier input to $3.9/(3.9+R22)$ (33kΩ)

The input impedance at the Pin40 is 3.35kΩ and DC is VR. C34 is input through 10μF.

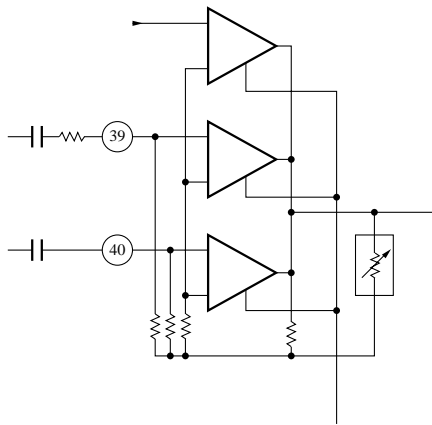

◇Receiver selector switch

Input : Pin10, Pin40

The switch changes over receiver input for hand set communications and MF input.

◇Receiver automatic pad

Control : Pin33

Common with transmitter automatic pad

◇Receiver buffer amplifier

Output : Pin9

Outputs a receiver signal for hand-free communications at low impedance.

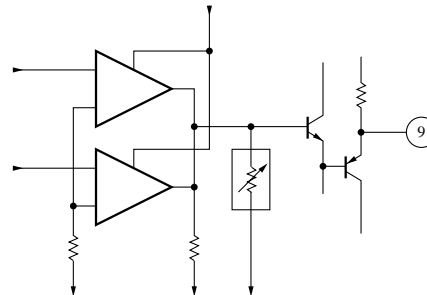

◇Transmitter automatic pad

Control : Pin33

Varies the transmitter/receiver gain by the value of the current supplied to the IC. A variable point can be moved by R18 (100kΩ). Increasing R18 causes AP to start operation at a higher line current.

■ Pin Descriptions (cont.)

◇ Receiver output

Output : Pin7, Pin8

Drives the ceramic receiver directly. The gain depends on an internal resistance and is about 23dB.

The frequency characteristic control capacitors C5 (0.033 μ F) and C6 (0.033 μ F), and output level control resistors R2(1k Ω)and R3 (1k Ω)are attached.

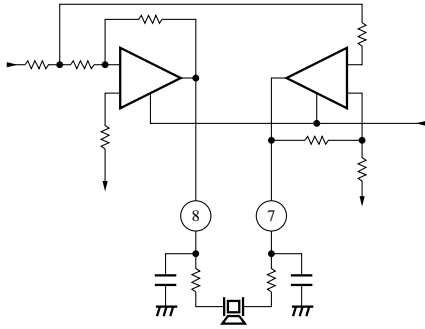

2. Hand-free Speech network Block (SP_V)

[Transmitter System]

◇ Microphone amplifier

Input : Pin12(minus input), Output : Pin13(emitter output)

The gain and frequency characteristics are determined by the external resistors R7(820 Ω)and R6(47k Ω), and capacitors C10 (1 μ F) and C9 (820pF). R37 (2.2k Ω) is a resistor for the power supply to ECM.

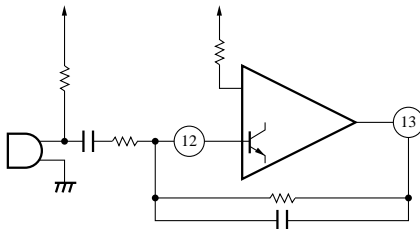

◇ Transmitter log amplifier

Input : Pin14(current input), Output : Pin15 (voltage output)

The input voltage is converted into a current at R8(390 Ω)and C11 (0.1 μ F). The attack and recovery time are determined by R9 (2.2M Ω)and C12(1 μ F).

◇ Receiver log amplifier

Input : Pin28 (current input), Output : Pin27 (voltage output)

The input voltage is converted into a current at R17 (2.2k Ω)and C20 (0.1 μ F). The attack and recovery time are determined by R16 (2.2M Ω)and C19 (1 μ F).

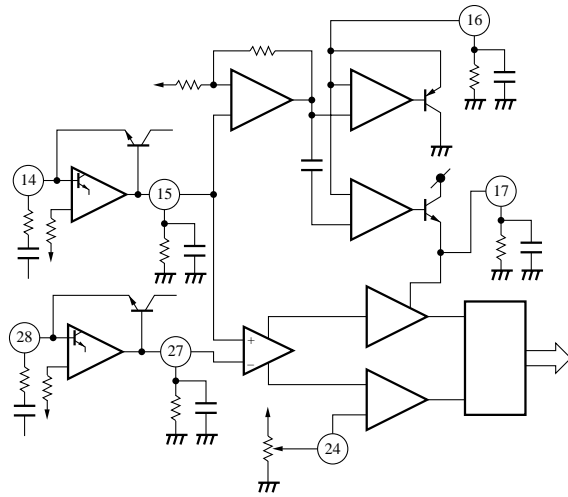

◇ Noise detector circuit

Output : Pin16, Pin17

When a continuous sound (noise 9) is input, the transmitter is set to -10dB.

The attack time for this operation is determined by R10 (100k Ω)and C27 (22 μ F), and the recovery time by R11(220k Ω)and C15 (2.2 μ F).

To stop the noise detector circuit, ground the Pin16.

◇ Receiver VR

Control : Pin24

A smoothed voltage is given by C17 (33 μ F).

Normally, VB (Pin35) is divided and given by R15 (20k Ω). The output becomes maximum when the voltage at the Pin24 is VB, and -31dB when 0V.

◇ Transmitter attenuator

Input : Pin18 (Z_i=15k Ω), Output : Pin19 (emitter output)

The input is of only AC component due to C14 (1 μ F).

At transmission time, an attenuation amount is varied within a range of about 0 to -36dB by the Gilbert circuit.

The Pin18 is 15k Ω and connected to the VB Pin (1.2V)

■ Pin Descriptions (cont.)

◇ Receiver attenuator

Input : Pin26 ($Z_i=15k\Omega$), Output : Pin25 (emitter output)

The input is of only AC component due to C18 (1 μ F).
At transmission time, an attenuation amount is varied with in a range of about 0 to -36dB by the Gilbert circuit.
The Pin25 is 15k Ω and connected to the VB pin (1.2V).

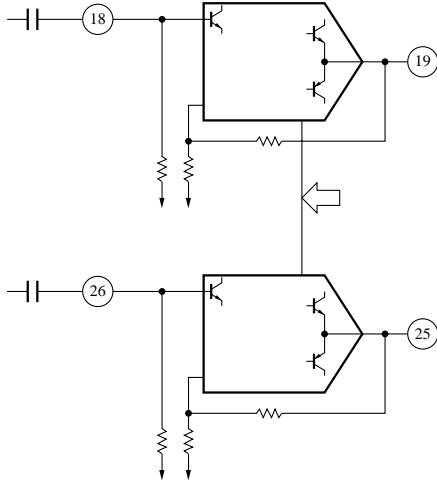

◇ Attenuator timing control (TAC)

Control : Pin20

Controls the transmitter/receiver attenuator switching speed with C16(2.2 μ F). $V_{20-29} \approx 0V$ in the transmitter mode, and $V_{20-29} \approx -120mV$ in the receiver mode.

◇ Transmitter attenuator control (TAC)

Control : Pin21

Controls the transmitter attenuator gain with R12(22k Ω).

◇ Receiver attenuator control (RAC)

Control : Pin23

Controls the receiver attenuator gain with R13 (22k Ω).

◇ Transmitter/receiver attenuator control (AC)

Control : Pin22

Controls the transmitter/receiver attenuator gain with R14 (27k Ω).

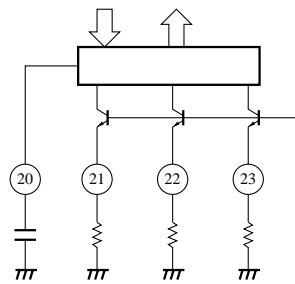

[Control System]

◇ High level ; 1 to 5V, Low level ; 0 to 0.5V

Controllable with the microcomputer.

◇ HS_U/SP_U selector switch

Control : Pin30

High : HS_U, Low : SP_U

◇ Transmitter mute switch

Control : Pin32, High : Transmission,

Low : Mute (MF transmission)

◇ Receiver mute switch

Control : Pin30,

High : Reception, Low : Mute (MF reception)

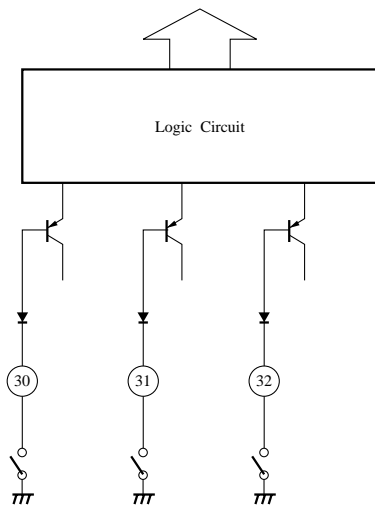

◇ Speaker amplifier

Input : Pin4, Output : Pin3, AGC : Pin2

Plus input amplifier of about 34 dB and driven at 25 Ω .

The input is of only AC component due to C3 (10 μ F). The output drives the 25 Ω speaker through C2 (220 μ F). The attack time and recovery time for AGC is determined by C1 (10 μ F) and R1(220k Ω).

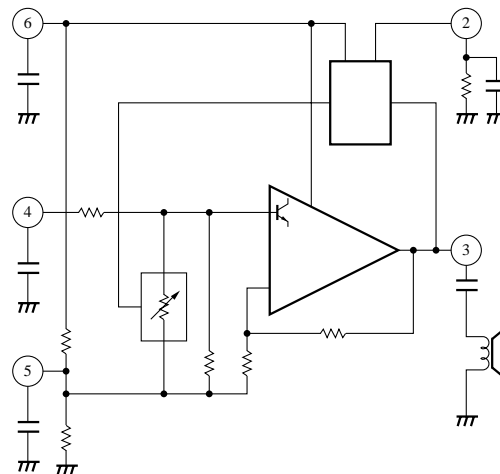

■ Pin Descriptions (cont.)

3. Power Supply Block

- ◇ HS_U voltage source (V_{CC1})
Stabilized by the Pin36 and C22 (220μF).
- ◇ HS_U reference voltage (V_{r1})
Results in V_{CC}/2 by resistance division (20kΩ) from the Pin34 and V_{CC}, and stabilized by C22 (220μF)
- ◇ Constant voltage source (VB)
Results in 1.2V by the Pin35 (band gap reference).
Stabilized by C23 (220μF)
- ◇ Ground pin (GND)
Pin1 (common with the GND pin of the speaker amplifier)

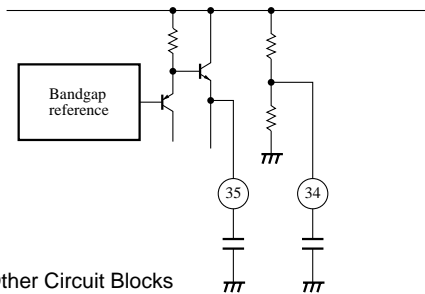

4. Other Circuit Blocks

- ◇ Balance network circuit
Prevents howling. (R25, R26, R24, C28, R27, R28)
- ◇ Telephone circuit connection circuit
Determines the polarity of the telephone circuit. (DB, R30, Q1, R32, R29, Q2, R31, C29)

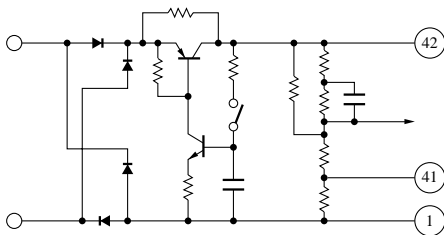

- ◇ Speaker amplifier voltage source (VPO)
Pin6. It is necessary to stabilize the power supply in order to prevent a receiver signal from leaking to the circuit. (R34, C30, D1, Q3, C31, R35, C32, Q4)
An AC adapter is available. (Q5, R33, D2, S5)
- ◇ Speaker amplifier reference voltage (Vr2)
Pin5 (V_{CC2}/2)
Stabilized by C4 (100μF)

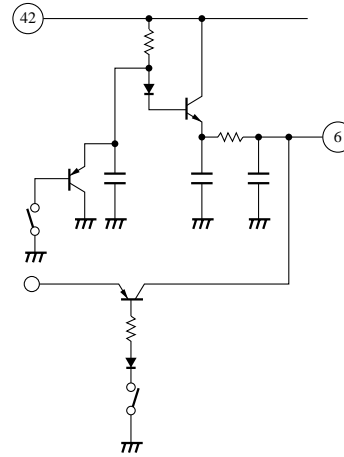

- ◇ SP_U voltage source (V_{CC2})
The Pin29 (normally connected to V_{CC} Pin1) is stabilized by C21 (100μF).
A voltage can be applied from the outside. (S4, Q6, R36, D3, S1)

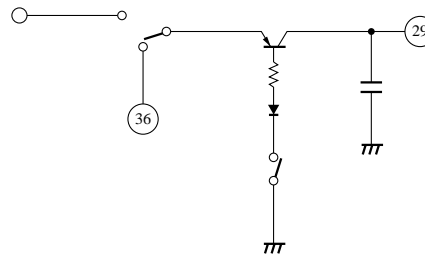

■ Supplementary Explanation

• Electrical Characteristics Design Reference Values (T_a=25°C)

Parameter	Symbol	Condition	min	typ	max	Unit
AC Impedance (1)	Z _{ac} (1)	HS _U I _L =20mA, f=1kHz	450	610	750	Ω
AC Impedance (2)	Z _{ac} (2)	HS _U I _L =90mA, f=1kHz	450	610	750	Ω
AC Impedance (3)	Z _{ac} (3)	SP _U I _L =20mA, f=1kHz	450	610	750	Ω

Note) The above characteristics are design reference values and not guaranteed values.

■ Characteristics Curve

