

MTD2006F

Dual full-bridge for a bipolar motor

Features

- Dual full-bridge for a bipolar stepper motor
- Constant current control (fixed frequency PWM control)
- Current decay selection (correspond to microstepping drive)
- Noise cancellation function (no need external RC)
- Integrated flywheel and flyback diodes
- Cross conduction protection
- Overheating alarm function
- Surface mount type package with heatsink (HSOP28)

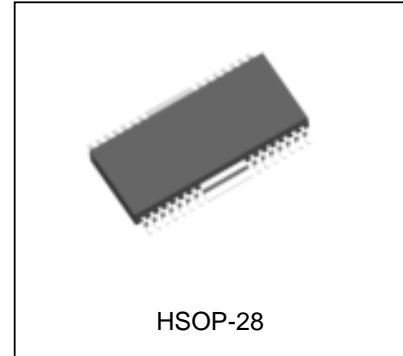

Absolute maximum ratings / Ta=25°C

Parameter	Symbol	Rating	Unit
Outout voltage	V _{mm}	35	V
Outout current	I _{OUT}	1.3	A
Logic supply	V _{cc}	6	V
Logic input voltage	V _{LOGIC}	0 to V _{cc}	V
Power dissipation*	P _T	3	W
Strage temperature range	T _{stg}	-40 to 150	°C
Junction temperature range	T _j	150	°C

*Mounted on glass epoxy board (50.8 × 50.8 × 1mm)

Pin assignment

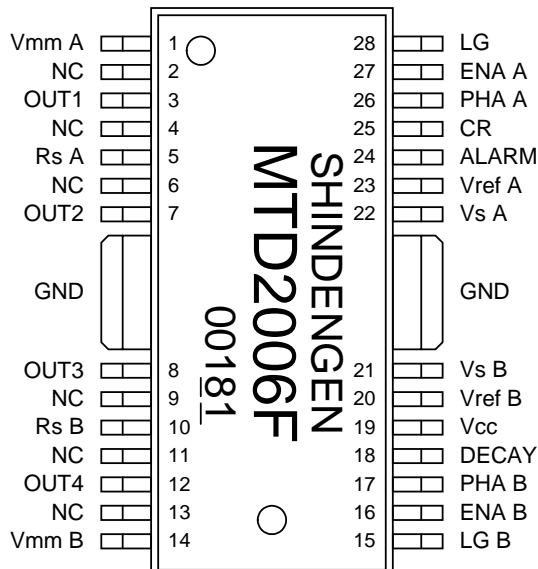

Truth table

ENA A or B	PHA A or B	OUT 1 or 4	OUT 2 or 3
L	L	L	H
L	H	H	L
H	*	OFF	OFF

*:don't care

DECAY	Output chopping
L	Sink+Source chopping
H	Source chopping

■ Electrical characteristics

Ta=25°C, Vcc=5V unless otherwise specified

Parameter	Symbol	Condition	MIN	TYP	MAX	Unit
Output stage						
Load supply	Vmm		-	-	31	V
Load supply current	I _{MM(OFF)}	Vmm=35V, V _{ENA} =5V	-	-	8	mA
Upper transistor saturation drop	V _{CE(sat)} ^H	I _C =0.8A	-	1.0	1.4	V
Lower transistor saturation drop	V _{CE(sat)} ^L	I _C =0.8A	-	1.0	1.4	V
Transistor leak current	I _R	Vmm=V _{CEO(SUS)}	-	-	10	μA
Upper diode forward drop	V _F ^H	I _F =0.8A	-	1.3	1.6	V
Lower diode forward drop	V _F ^L	I _F =0.8A	-	1.3	1.5	V
Logic stage						
Logic supply	Vcc		4.75	-	5.25	V
Logic supply current (output ON)	I _{CC(ON)}	V _{ENA} =0V	-	25	33	mA
Logic supply current (output OFF)	I _{CC(OFF)}	V _{ENA} =5V	-	19	26	mA
PHA "H" input voltage	V _{PHA} ^H		2.3	-	Vcc	V
PHA "L" input voltage	V _{PHA} ^L		GND	-	0.8	V
PHA "H" input current	I _{PHA} ^H	V _{PHA} =5V	-	-	10	μA
PHA "L" input current	I _{PHA} ^L	V _{PHA} =0V	-	-100	-150	μA
ENA "H" input voltage	V _{ENA} ^H		2.3	-	Vcc	V
ENA "L" input voltage	V _{ENA} ^L		GND	-	0.8	V
ENA "H" input current	I _{ENA} ^H	V _{ENA} =5V	-	-	10	μA
ENA "L" input current	I _{ENA} ^L	V _{ENA} =0V	-	-100	-150	μA
DECAY "H" input voltage	V _{DEC} ^H		2.3	-	Vcc	V
DECAY "L" input voltage	V _{DEC} ^L		GND	-	0.8	V
DECAY "H" input current	I _{DEC} ^H	V _{DEC} =5V	-	-	10	μA
DECAY "L" input current	I _{DEC} ^L	V _{DEC} =0V	-	-100	-150	μA
Vref input current	I _{ref}	Vref=0V	-	-1	-10	μA
Vs input current	I _{SENSE}	Vs=0V	-	-1	-10	μA
Comparator threshold	Vs	Vref=0.5V	0.475	0.5	0.525	V
Chopping frequency	f _{CHOP}	Ct=3300pF, Rt=20kΩ	-	20	-	kHz
Blanking time	t _b	Ct=3300pF, Rt=20kΩ	-	1.35	-	μs
Vs maximum voltage	Vs(max)		-	-	1.0	V
ALARM leak current	I _{R(ALM)}	V _{ALM} =5V	-	-	10	μA
ALARM input current	I _{ALM}	V _{ALM} =0.5V	-	-	2	mA
ALARM operation temperature	T _{ALM}		-	140	-	°C

■ Thermal resistance

Symbol	Rating	Unit
θ _{ja} *	41	°C/W

*Mounted on glass epoxy board (50.8 × 50.8 × 1mm)

Internal equation circuit / Typical application

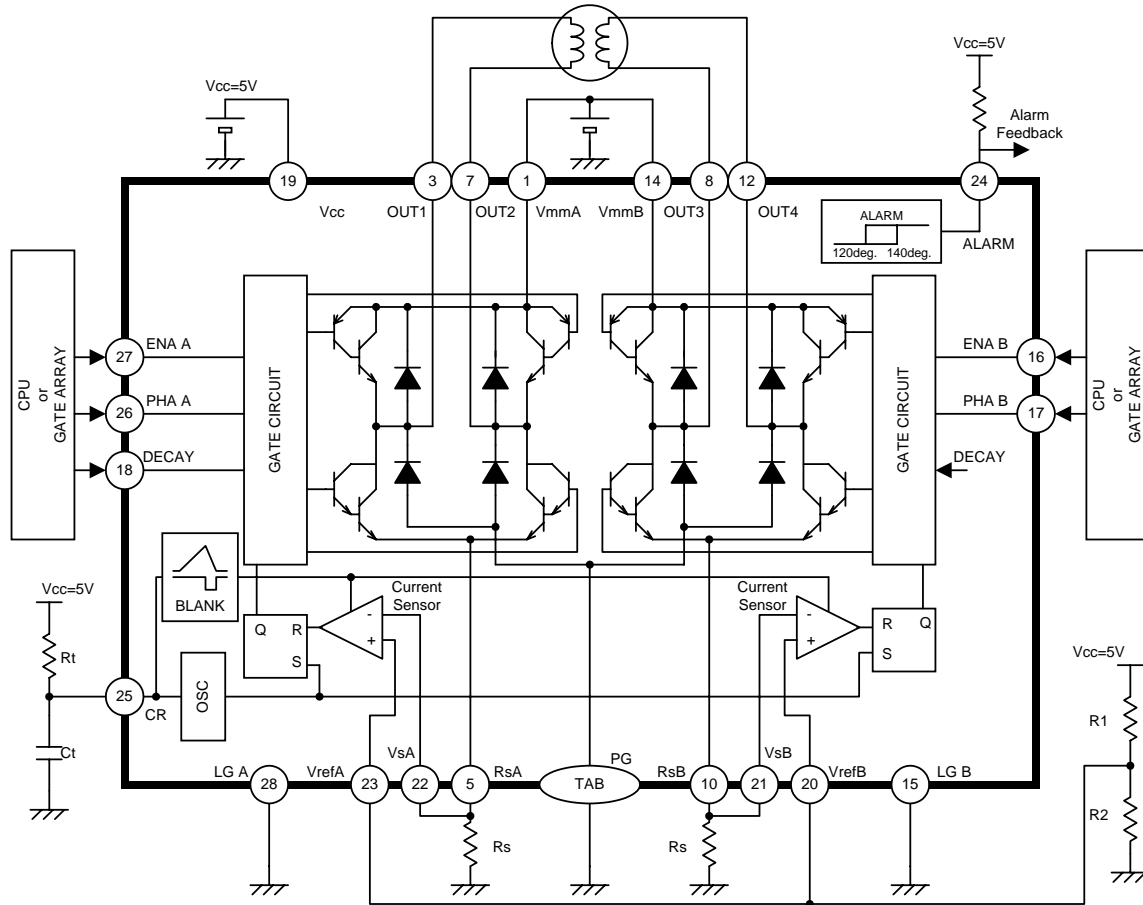

Constant chopping current level Chopping frequency

$$I_o = \frac{V_{ref}}{R_s}$$

$$f = \frac{1}{0.75 \cdot C_t \cdot R_t}$$

Recommended component values

Symbol	Value	Unit
R _t	7.5 to 30	kΩ
C _t	2200 to 4700	pF
R ₁ +R ₂	≤10	kΩ

Outline dimension

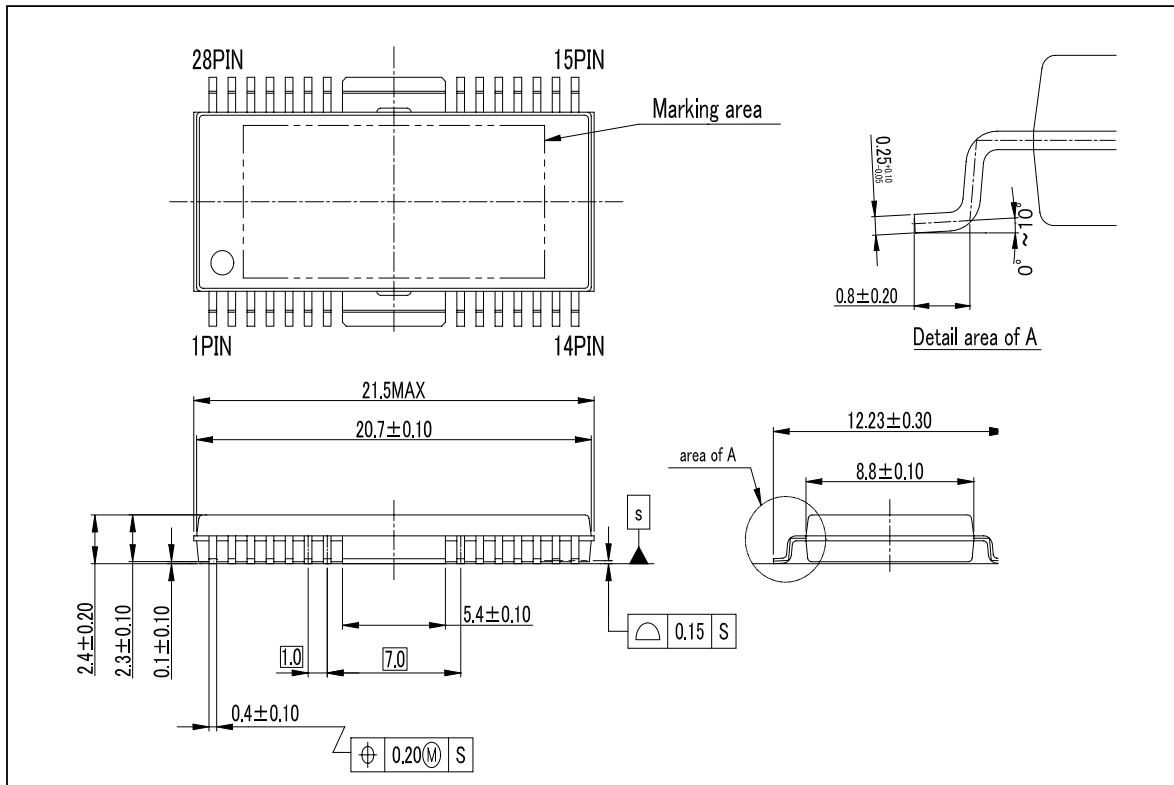

(Unit : mm)

■ This device fully meets the reliability and quality control standards described in our company's catalog. If this device is to be used in a situation where its misuse or failure might cause serious injury or death, consult with our company. Reliability and quality control standards for this device are considered adequate when it is used with the following type of end equipment.

Standard applications

Computers, OA and other office equipment, Communication terminal, Measurement machine tools, Audio-visual, Game and other amusements, Household electric appliances, Personal items, Industrial robot, etc.

Special applications where the device may or not be suitable include the following.

Transportation and conveyance (cargo loading) equipment, Primary communications equipment, Traffic signal control equipment, Fire and burglary alarms, Various safety devices, Medical equipment, etc.

Other special applications where the device reliability is not considered high enough include the following.

Atomic power control systems, Aviation equipment, Aerospace equipment, Submarine relay equipment, Life support equipment, etc.

■ Our company makes a constant effort to improve the quality and reliability of our products. However, it is the customer's responsibility to provide safety. Take the appropriate steps to prevent personal injury, fire, and damage by providing redundancy equipment, fire containment equipment, and devices to protect personnel and equipment from operational mistakes.

If you want any more detail information and design application, please contact sales office regarding any questions you may have.

SHINDENGEN ELECTRIC MFG. CO., LTD. reserves the right to make, from time to time, such departures from the detail specifications as may be required to permit improvements in the design of its products.

The information included herein is believed to be accurate and reliable. However, SHINDENGEN ELECTRIC MFG. CO., LTD. assumes no responsibility for its use; nor for any infringements of patents or other rights of third parties, which may result from its use.