

TC5023BP

C²MOS DIGITAL INTEGRATED CIRCUIT
SILICON MONOLITHIC

TC5023BP 16-LINE DATA SELECTOR/MULTIPLEXER

TC5023BP is data selector which selects one of 16 input signals $X_0 \sim X_{15}$ according to binary address inputs A, B, C and D.

The data input (X_n) which corresponds to the binary address appears inverted on output \bar{Z} .

If STROBE input is set to "H", output \bar{Z} becomes "H" regardless of other inputs.

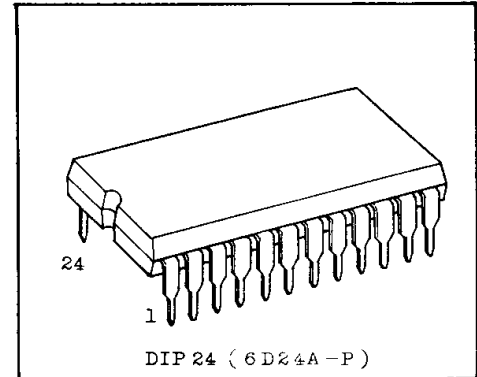

ABSOLUTE MAXIMUM RATINGS

CHARACTERISTIC	SYMBOL	RATING	UNIT
DC Supply Voltage	V _{DD}	V _{SS} -0.5 ~ V _{SS} +20	V
Input Voltage	V _{IN}	V _{SS} -0.5 ~ V _{DD} +0.5	V
Output Voltage	V _{OUT}	V _{SS} -0.5 ~ V _{DD} +0.5	V
DC Input Current	I _{IN}	±10	mA
Power Dissipation	P _D	300	mW
Storage Temperature Range	T _{stg}	-65 ~ 150	°C
Lead Temp./Time	T _{sol}	260°C · 10sec	

PIN ASSIGNMENT

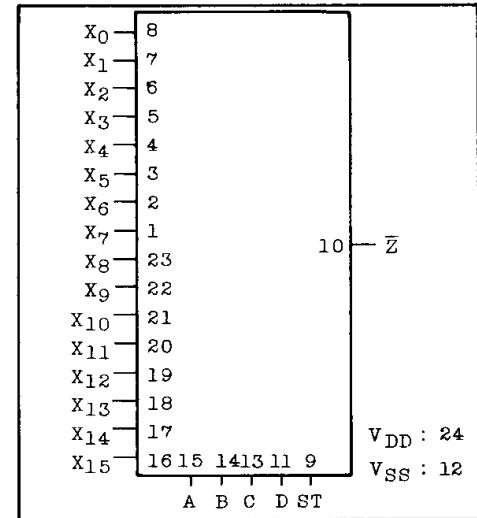

LOGIC DIAGRAM

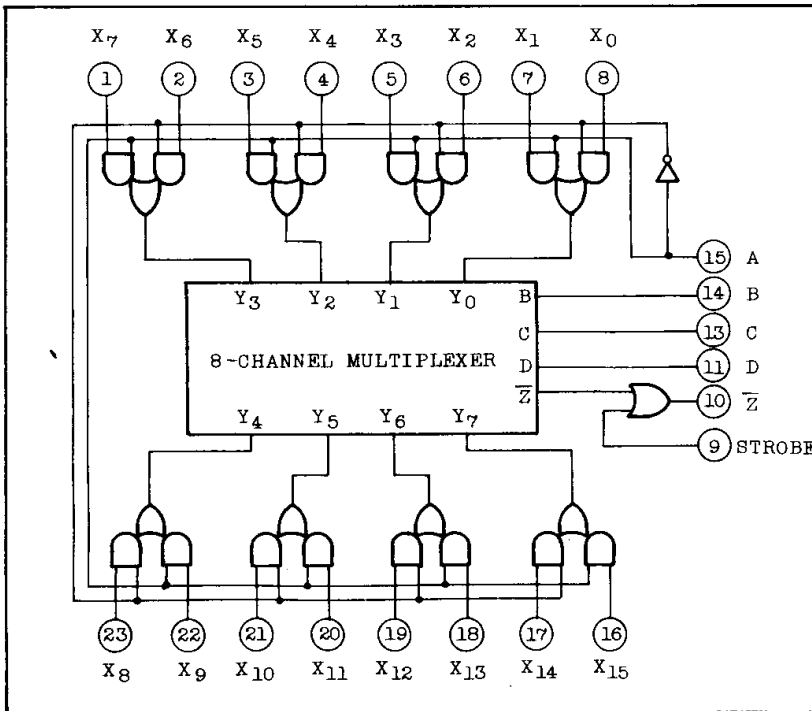

TRUTH TABLE

INPUTS					OUTPUT
D	C	B	A	ST	\bar{Z}
*	*	*	*	H	H
L	L	L	L	L	\bar{X}_0
L	L	L	H	L	\bar{X}_1
L	L	H	L	L	\bar{X}_2
L	L	H	H	L	\bar{X}_3
L	H	L	L	L	\bar{X}_4
L	H	L	H	L	\bar{X}_5
L	H	H	L	L	\bar{X}_6
L	H	H	H	L	\bar{X}_7
H	L	L	L	L	\bar{X}_8
H	L	L	H	L	\bar{X}_9
H	L	H	L	L	\bar{X}_{10}
H	L	H	H	L	\bar{X}_{11}
H	H	L	L	L	\bar{X}_{12}
H	H	L	H	L	\bar{X}_{13}
H	H	H	L	L	\bar{X}_{14}
H	H	H	H	L	\bar{X}_{15}

* : Don't Care

RECOMMENDED OPERATING CONDITIONS (VSS=0V)

CHARACTERISTIC	SYMBOL	MIN.	TYP.	MAX.	UNIT
Supply Voltage	VDD	3	-	18	V
Input Voltage	VIN	0	-	VDD	V
Operating Temp.	Topr	-40	-	85	°C

ELECTRICAL CHARACTERISTICS (VSS=0V)

CHARACTERISTIC	SYMBOL	TEST CONDITIONS	VDD (V)	-40°C		25°C			85°C		UNIT	
				MIN.	MAX.	MIN.	TYP.	MAX.	MIN.	MAX.		
High Level Output Voltage	VOH	IOUT < 1µA VIN = VSS, VDD	5	4.95	-	4.95	5.00	-	4.95	-	V	
			10	9.95	-	9.95	10.00	-	9.95	-		
			15	14.95	-	14.95	15.00	-	14.95	-		
Low Level Output Voltage	VOL	IOUT < 1µA VIN = VSS, VDD	5	-	0.05	-	0.00	0.05	-	0.05	V	
			10	-	0.05	-	0.00	0.05	-	0.05		
			15	-	0.05	-	0.00	0.05	-	0.05		
High Level Output Current	IOH	VOH = 4.6V VOH = 9.5V VOH = 13.5V VIN = VSS, VDD	5	-0.2	-	-0.16	-	-	-0.12	-	mA	
			10	-0.5	-	-0.4	-	-	-0.3	-		
			15	-1.4	-	-1.2	-	-	-1.0	-		
Low Level Output Current	IOL	VOL = 0.4V VOL = 0.5V VOL = 1.5V VIN = VSS, VDD	5	0.52	-	0.44	-	-	0.36	-	mA	
			10	1.3	-	1.1	-	-	0.9	-		
			15	3.6	-	3.0	-	-	2.4	-		
High Level Input Voltage	VIH	VOUT=0.5V, 4.5V VOUT=1.0V, 9.0V VOUT=1.5V, 13.5V IOUT < 1µA	5	3.5	-	3.5	2.75	-	3.5	-	V	
			10	7.0	-	7.0	5.5	-	7.0	-		
			15	11.0	-	11.0	8.25	-	11.0	-		
Low Level Input Voltage	VIL	VOUT=0.5V, 4.5V VOUT=1.0V, 9.0V VOUT=1.5V, 13.5V IOUT < 1µA	5	-	1.5	-	2.25	1.5	-	1.5	V	
			10	-	3.0	-	4.5	3.0	-	3.0		
			15	-	4.0	-	6.75	4.0	-	4.0		
Input Current	High Level	IIH	VIH = 18V	18	-	0.3	-	10 ⁻⁵	0.3	-	1.0	µA
	Low Level	IIL	VIL = 0V	18	-	-0.3	-	-10 ⁻⁵	-0.3	-	-1.0	
Quiescent Supply Current	IDD	VIN = VSS, VDD *	5	-	20	-	0.005	20	-	150	µA	
			10	-	40	-	0.010	40	-	300		
			15	-	80	-	0.015	80	-	600		

* All valid input combinations

SWITCHING CHARACTERISTICS (Ta=25°C, VSS=0V, CL=50pF)

CHARACTERISTIC	SYMBOL	TEST CONDITIONS	VDD (V)	MIN.	TYP.	MAX.	UNIT
Output Rise Time	tTLH		5	-	130	400	ns
			10	-	65	200	
			15	-	50	160	
Output Fall Time	tTHL		5	-	100	200	ns
			10	-	50	100	
			15	-	40	80	

TC5023BP

SWITCHING CHARACTERISTICS (Ta=25°C, VSS=0V, CL=50pF)

CHARACTERISTIC	SYMBOL	TEST CONDITIONS	VDD (V)	MIN.	TYP.	MAX.	UNIT
(LOW-HIGH) Propagation Delay Time (Xn,A,B,C,D - Z)	tpLH		5	-	900	1800	ns
			10	-	370	800	
			15	-	250	550	
(HIGH-LOW) Propagation Delay Time (Xn,A,B,C,D - Z)	tpHL		5	-	650	1400	ns
			10	-	260	600	
			15	-	190	400	
(LOW-HIGH) Propagation Delay Time (STROBE - Z)	tpLH		5	-	280	600	ns
			10	-	130	300	
			15	-	100	250	
(HIGH-LOW) Propagation Delay Time (STROBE - Z)	tpHL		5	-	800	1600	ns
			10	-	340	700	
			15	-	230	500	
Input Capacity	CIN	All Inputs		-	5	7.5	pF

SWITCHING TIME TEST CIRCUIT AND WAVEFORMS

