

## BCM3118B QAMLINK<sup>®</sup> DVB/DAVIC RECEIVER

### BCM3118B FEATURES

- Downstream QAM receiver for international applications
- Integrated QAMLink receiver with Forward Error Correction (FEC)
  - 1-7 MBaud variable symbol rate receiver
  - Supports variable channelization
  - Supports 4, 16, 32, 64, 128 and 256-QAM
  - Digital demodulator, Nyquist filters, tracking loops, and 20-tap adaptive decision feedback equalizer
  - Digital derotator for wideband carrier phase tracking
- DVB/DAVIC-compliant FEC decoder
  - Reed-Solomon (N,K) = 204,188: t=8
  - Convolutional detinterleaver, I=1-12 with internal RAM, I=204 with external RAM
- I<sup>2</sup>C or SPI-compatible microcontroller interface
- Integrated 10-bit analog-to-digital converter
- On-chip generation of all clock and control signals
- JTAG test interface
- 100-pin PQFP Package

### SUMMARY OF BENEFITS

- Fully integrated solution enables less-complex, low-cost cable modems and cable-TV set-top boxes
- Significantly increases channel capacity
- Variable data rates enable systems to adapt to channels encoded at different data rates
- Integrated A/D converter reduces system manufacturing costs and complexity
- A universal chip solution that supports DVB, DAVIC, ITU-T J.83/Annex A and Annex C, IEEE 802.14-based systems
- Digital adaptive equalizers ensure robust performance in the presence of multipath reflections

### Interactive Set-Top Box with DOCSIS and Watch and Record Dual Video Channels

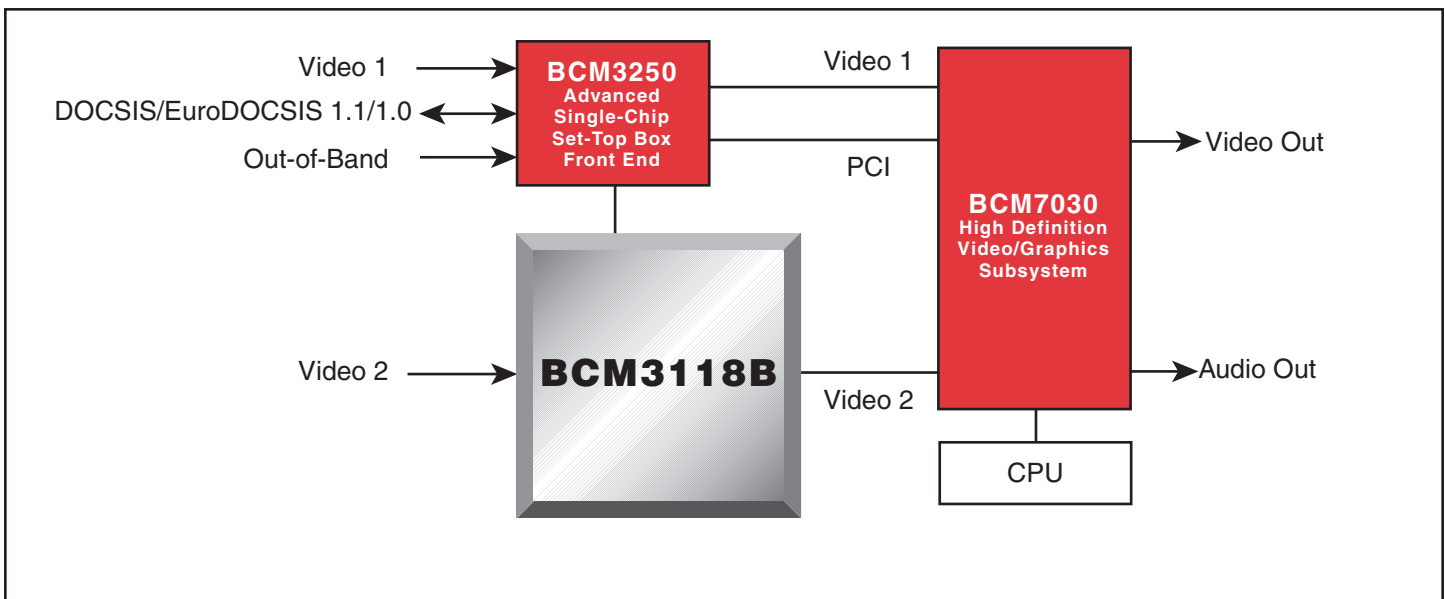

# BCM3118B OVERVIEW

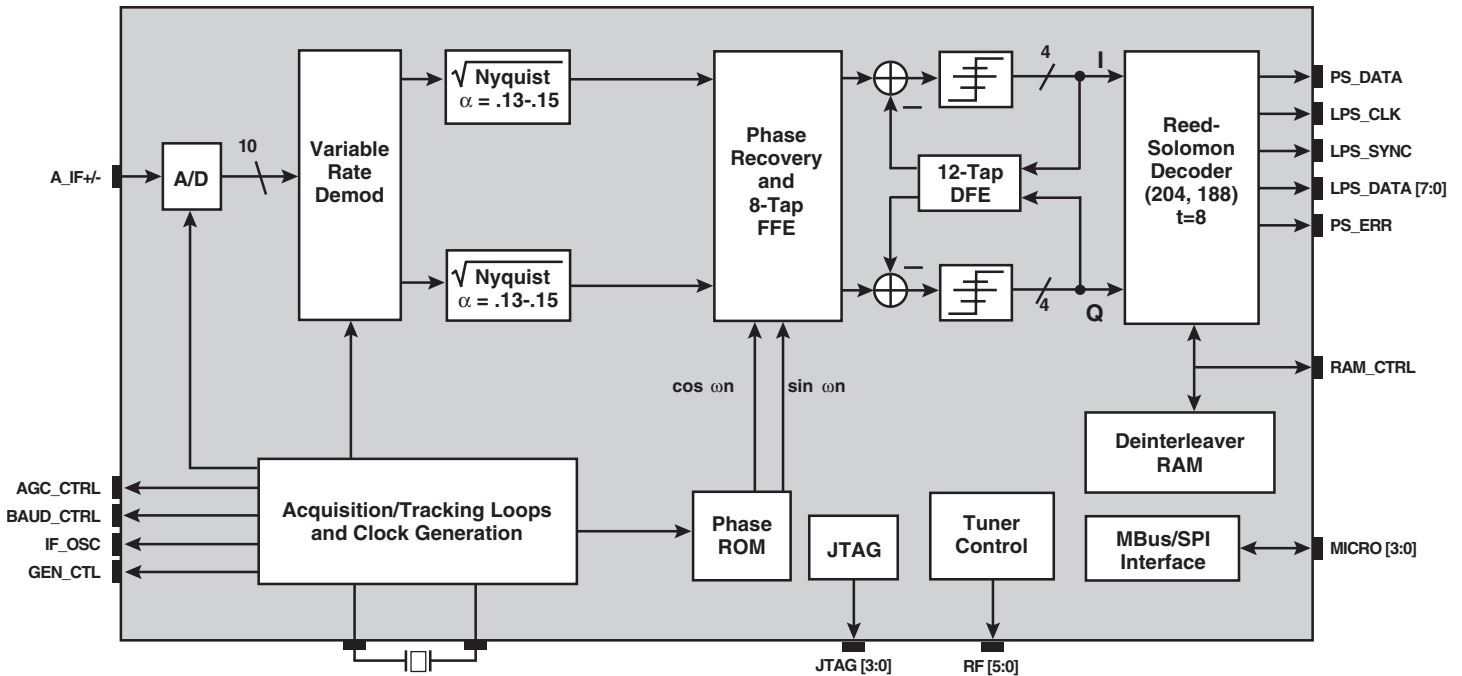

The **BCM3118B** QAMLink DVB/DAVIC Receiver with FEC is an integrated digital transmission solution for cable modems, cable-TV set-top boxes and digital microwave radios. Its bandwidth-efficient feature set expands the existing potential bandwidth of a standard analog network and provides operators with reliable, error-free transmission. Optimized for high-volume manufacturing, the **BCM3118B** is a highly integrated solution that reduces the system-level chip count, the cost, and the complexity associated with manufacturing RF receivers.

A single-chip solution, the **BCM3118B** has a 10-bit A/D converter, a 256-QAM demodulator with square-root raised-cosine receive filters, an adaptive equalizer with an embedded phase recovery derotator, acquisition and tracking loops, and a DVB/DAVIC-compliant Reed-Solomon FEC decoder with deinterleaver. The demodulator supports QPSK, 16, 32, 64, 128 and 256-QAM formats and adapts to channels encoded at different data rates up to 56 Mbps. The equalizer in the **BCM3118B** achieves transmission performance within 1 dB of theory over worse-case channels with multipath delays as long as 2.4 microseconds at 5 MBaud or 1.7 microseconds at 7 MBaud and amplitudes within .5 dB of the desired signals. With this level of performance, the **BCM3118B** combats the effects of channel distortions commonly found in cable-TV systems. The

Broadcom®, the pulse logo, QAMLink® and Connecting everything® are trademarks of Broadcom Corporation and/or its subsidiaries in the United States and certain other countries. All other trademarks are the property of their respective owners.

Connecting  
everything®

## BROADCOM CORPORATION

16215 Alton Parkway, P.O. Box 57013  
Irvine, California 92619-7013

© 2003 by BROADCOM CORPORATION. All rights reserved.

3118B-PB05-R-06.13.03

**BCM3118B** has an integrated A/D converter, which eliminates the costs associated with fine tuning of external components during high-volume production.

The **BCM3118B** samples the analog IF waveform being delivered to **BCM3118B** by the integrated A/D converter. The signal is then digitally mixed to baseband and filtered by dual square-root Nyquist filters. Inter-symbol interference is then removed by the adaptive decision feedback equalizer. A decision slicer, which supports constellations up to 256-QAM, formats the equalized data. The data is then fed into a DVB/DAVIC-compliant synchronization block, deinterleaver, Reed-Solomon FEC, and derandomizer. The final error-corrected output is delivered in an MPEG-2 transport format.

The **BCM3118B** can be used as a stand-alone chip or with Broadcom's BCM3250 for a complete watch and record solution with EuroDOCSIS. Compliant with the ITU-T J83/Annex A and Annex C, DVB/DAVIC and the IEEE802.14 cable transmission standards for QAM downstream, the **BCM3118B** is a universal downstream solution for worldwide coaxial cable applications.



Phone: 949-450-8700  
FAX: 949-450-8710  
Email: [info@broadcom.com](mailto:info@broadcom.com)  
Web: [www.broadcom.com](http://www.broadcom.com)