

PRELIMINARY
 Notice ; This is not a final specification.
 some parametric limits are subject to change.

M65853FP



DIGITAL ECHO WITH MICROPHONE MIXING CIRCUIT

DESCRIPTION

The M65853 is a CMOS IC built-in Digital Echo function with microphone peripheral circuits for "Karaoke" equipment packed in a single chip.
 It is suitable for "Karaoke" equipments such as Video CD Player, Mini Stereo, CD-Radio Cassette, TV or VCR.

FEATURES

- High performance digital echo circuit thanks to 16Kbit memory
- Built-in surround function which works Simulated Stereo for monaural source and Stereo Surround for stereo source
- ALC-equipped microphone amplifiers permit excessively high input. ALC operating voltage can be set as desired.
- 2 microphone volumes, echo effect volume and echo feedback volume are included
- Stereo microphone-line mixing amplifiers
- Karaoke entertainment functions such as vocal cut and automatic vocal support system
- Built-in current-control oscillation circuit
- Built-in automatic reset circuit activated with power on
- 5V single power supply

RECOMMENDED OPERATING CONDITION

- Supply voltage range ••••• Vcc = 4.5 ~ 5.5V
- Rated supply voltage ••••• Vcc = 5V

PIN CONFIGURATION

MCLKCONT	1	42	MIC SW
VALC	2	41	DATA
MIC1IN	3	40	CLOCK
ALC1	4	39	LATCH
MIC1NFIN	5	38	PS2
MIC1OUT	6	37	PS1
MIC1VOLIN	7	36	LOU
MIC2IN	8	35	T ROUT
ALC2	9	34	VCFIL
MIC2NFIN	10	33	LIN1
MIC2OUT	11	32	RIN1
MIC2VOLIN	12	31	LIN2
MICOUT	13	30	RIN2
LPF1IN1	14	29	VOL IN
LPF1IN2	15	28	LPF2OUT
LPF1OUT	16	27	LPF2IN2
ADINTOUT	17	26	LPF2IN1
ADINTIN	18	25	DAINTOUT
ADCONT	19	24	DAINTIN
REF	20	23	DACONT
GND	21	22	VCC

SYSTEM CONFIGURATION

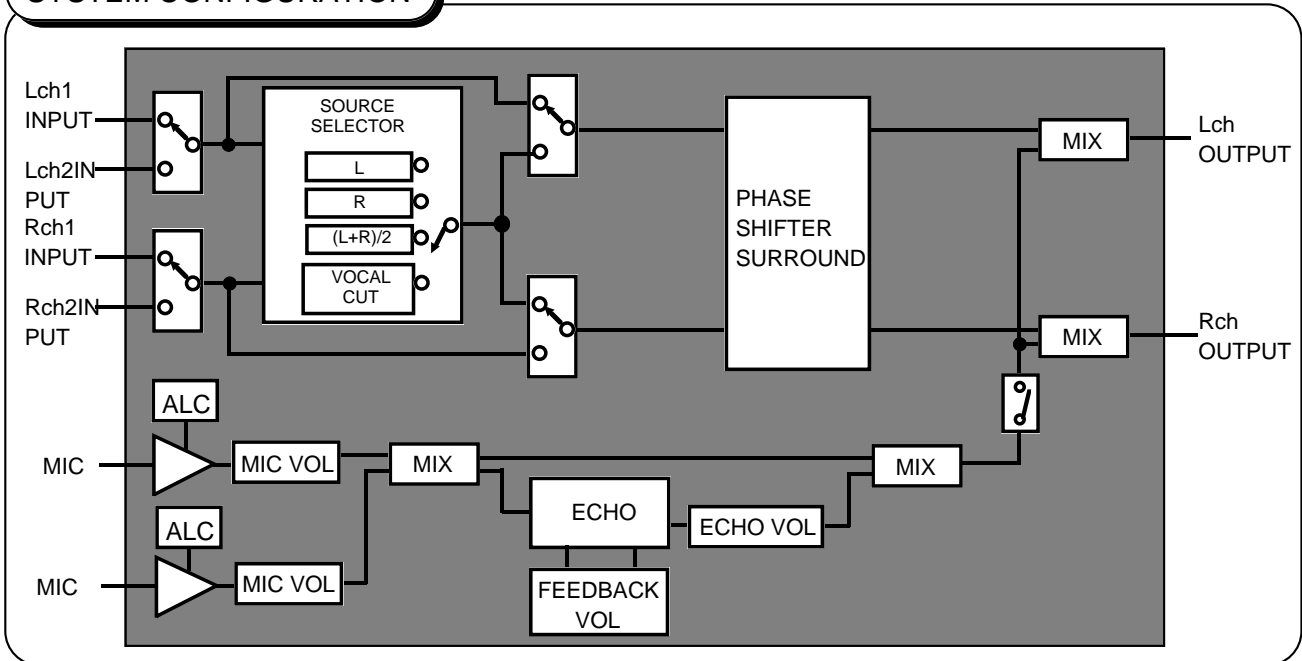

PRELIMINARY
 Notice ; This is not a final specification.
 some parametric limits are subject to change.

MITSUBISHI SOUND PROCESSOR ICs

M65853FP



DIGITAL ECHO WITH MICROPHONE MIXING CIRCUIT

PIN CONFIGURATION

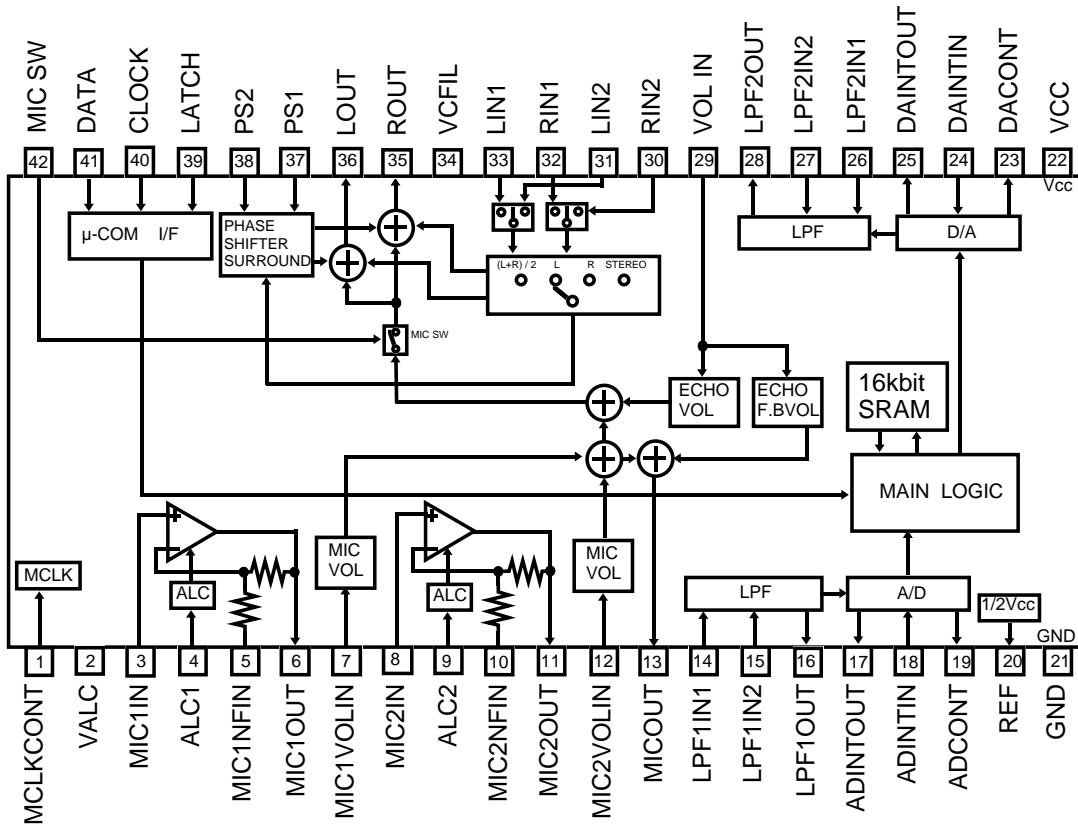

PRELIMINARY
 Notice ; This is not a final specification.
 some parametric limits are subject to change.



DIGITAL ECHO WITH MICROPHONE MIXING CIRCUIT

PIN DESCRIPTION

Pin No.	Symbol	Nam	I/O	Function
1	MCLKCONT	Clock control	—	Controls built-in clock generation circuit with external R
2	VALC	ALC operating voltage setting terminal	—	To set ALC operating voltage according to applied voltage
3	MIC1IN	Microphone 1 input	I	To connect MIC1
4	ALC1	ALC1 control	—	To connect ALC1 attack / recovery time setting capacitor
5	MIC1NFIN	Microphone 1 negative feedback input	I	To connect low cut-off frequency of MIC1 amplifier setting capacitor
6	MIC1OUT	Microphone 1 output	O	To connect capacitor to reduce noise generated at time of volume change
7	MIC1VOLIN	Microphone 1 volume input	I	
8	MIC2IN	Microphone 2 input	I	To connect MIC2
9	ALC2	ALC2 control	—	To connect ALC2 attack/recovery time setting capacitor
10	MIC2NFIN	Microphone 2 negative feedback input	I	To connect low cut-off frequency of MIC2 amplifier setting capacitor
11	MIC2OUT	Microphone 2 input	I	To connect capacitor to reduce noise generated at time of volume change
12	MIC2VOLIN	Microphone 2 volume input	I	
13	MICOUT	Microphone output	O	Mixing output of MIC1 and MIC2
14	LPF1IN1	Low pass filter 1 input 1	I	Pre-filter before A/D convertor for digital delay
15	LPF1IN2	Low pass filter 1 input 2	I	
16	LPF1OUT	Low pass filter 1 output	O	
17	ADINTOUT	A/D integrator output	O	Composes D/A conversion integrator with external capacitor
18	ADINTIN	A/D integrator input	I	
19	ADCONT	A/D control	—	To determine adaptive time constant of A/D convertor with ADM system
20	REF	Reference power output	—	To connect 1/2 Vcc output and filter capacitor
21	GND	Ground	—	

PRELIMINARY
 Notice ; This is not a final specification.
 some parametric limits are subject to change.

MITSUBISHI SOUND PROCESSOR ICs

M65853FP



DIGITAL ECHO WITH MICROPHONE MIXING CIRCUIT

Pin No.	Symbol	Nam	I/O	Function
22	VCC	Power supply	—	
23	DACONT	D/A control	—	To determine adaptive time constant of D/A convertor with ADM system
24	DAINTIN	D/A Integrator input	I	Composes D/A conversion integrator with external capacitor
25	DAINTOUT	D/A integrator output	O	
26	LPF2IN1	Low pass filter 2 input 1	I	Post-filter after D/A convertor for digital delay
27	LPF2IN2	Low pass filter 2 input 2	I	
28	LPF2OUT	Low pass filter 2 output	O	
29	VOLIN	Echo effect / Echo feed back volume input	I	To connect capacitor to reduce noise generated at time of volume change
30	RIN2	Rch line input2	I	Rch line input2
31	LIN2	Lch line input2	I	Lch line input2
32	RIN1	Rch line input1	I	Rch line input 1
33	LIN1	Lch line input1	I	Lch line input1
34	VCFIL	Vocal cut filter	—	Processes frequencies lower than the vocal band
35	ROUT	Rch output	O	Rch mixing output
36	LOU	Lch output	O	Lch mixing output
37	PS1	Phase shift input 1	I	Determines a constant at time of phase shift
38	PS2	Phase shift input 2	I	
39	LATCH	LATCH	I	Latch input via serial bus
40	CLOCK	CLOCK	I	Clock input via serial bus
41	DATA	DATA	I	Data input via serial bus
42	MIC SW	Microphone SW	I	L: MIC OFF H: MIC ON

PRELIMINARY
 Notice ; This is not a final specification.
 some parametric limits are subject to change.



DIGITAL ECHO WITH MICROPHONE MIXING CIRCUIT

ELECTRICAL CHARACTERISTICS

(Vcc=5V,f=1kHz,vi=100mVrms,Ta=25°C Unless otherwise noted)

Symbol	Parameter	Test conditions	Limits			Unit	
			Min	Typ	Max		
TOTAL	Icc	Circuit current	No signal provided	—	35		mA
	Gvo	Amplifier gain	Vo = -17dBV		47		dB
Microphone amplifier	THD1	Distortion	Vo = -17dBV,with ALC not operated	—	0.1	0.5	%
	THD2	Distortion	Vi= -37dBV,with ALC operated	—	3.0	6.0	%
	VoALC	ALC operating voltage measurement error	measurement : -10 to +3dBV	-3	0	+3	dB
	TALCAT	ALC attack time	C=4.7μF	25	40	55	msec
	TALCRE	ALC recovery time	C=4.7μF	1.0	1.5	2.0	sec
	VoMAX	Maximum output voltage	THD=10%	1.3	1.4	—	Vrms
	No	Output noise voltage	Gv=47dB,f=100 to 5KHz	—	-68	-57	dBV
	Zi	Input impedance		5	10	20	KΩ
Mic volume	Gv	I/O voltage gain	Volume max	-3	0	+3	dB
	ATTmax	Maximum attenuation	Volume min	—	-72	-67	dBV
	THD	Distortion	Volume max	—	0.15	0.30	%
	ViMAX	Maximum input voltage	THD=10%	1.4	1.7	—	Vrms
	No	Output noise voltage	JIS - A	—	-96	-90	dBV
Echo effect / Echo feed back volume	Gv	I/O voltage gain	Volume max	-3	0	+3	dB
	ATTmax	Maximum attenuation	Volume min	—	-72	-67	dBV
	THD	Distortion	Volume max	—	0.15	0.30	%
	VoMAX	Maximum output voltage	THD=10%	1.1	1.4	—	Vrms
	No	Output noise voltage	JIS - A	—	-96	-90	dBV

PRELIMINARY
 Notice ; This is not a final specification.
 some parametric limits are subject to change.

M65853FP



DIGITAL ECHO WITH MICROPHONE MIXING CIRCUIT

Symbol	Parameter	Test conditions	Limits			Unit	
			Min	Typ	Max		
Digital echo	Gv	I/O voltage gain	-3	0	+3	dB	
	VoMAX	Maximum output voltage	THD=10%	1.1	1.4	—	Vrms
Digital echo	Td	Delay Time	Sets Delay time with microcomputer.		98.3		msec
					131.1		msec
					147.5		msec
					196.6		msec
	THD	Distortion	Td=98.3mS,30KHzLPF	1.0	1.0	2.0	%
			Td=131.1mS,30KHzLPF	1.5	1.5	3.0	%
			Td=147.5mS,30KHzLPF	1.5	1.5	3.0	%
			Td=196.6mS,30KHzLPF	2.0	2.0	4.0	%
	No	Output noise voltage	Vi=0mVrms,JIS - A Td=98.3msec,Rg=620Ω	-72	-87	—	dBV
			Vi=0mVrms,JIS - A Td=131.1msec,Rg=620Ω	-70	-85	—	dBV
			Vi=0mVrms,JIS - A Td=147.5msec,Rg=620Ω	-70	-85	—	dBV
			Vi=0mVrms,JIS - A Td=196.6msec,Rg=620Ω	-67	-82	—	dBV
LINE	Gv	I/O voltage gain	-3	0	+3	dB	
	THD	Distortion	30KHzLPF	—	0.02	0.04	%
	VoMAX	Maximum output voltage	THD=10%	1.1	1.7	—	Vrms
	No	Output noise voltage	JIS - A,MIC SW OFF	-90	-95	—	dBV
	CS	Channel separation	Lin=400Hz,Rout JIS - A		-70		dB
	Zi	Input impedance		10	20	30	KHz
	Grej	Vocal removal ratio	Vocal cut	14	18	—	dB

PRELIMINARY
 Notice ; This is not a final specification.
 some parametric limits are subject to change.

M65853FP



DIGITAL ECHO WITH MICROPHONE MIXING CIRCUIT

ABSOLUTE MAXIMUM

Symbol	Nam	Test conditions	Ratings	Units
Vcc	Supply voltage		6.0	V
Vi	Circuit current		-0.3 ~ Vcc+0.3	V
Pd	Input Voltage		1.1	W
Topr	Operating temperature		-20 ~ +75	°C
Tstg	Storage temperature		-40 ~ +125	°C

RECOMMENDED OPERATING CONDITION

Symbol	Parameter	Test conditions	Limits			Units
			Min	Typ	Max	
Vcc	Supply voltage		4.5	5	5.5	V
VIL	L input level		0	—	0.3VDD	V
VIH	H input level		0.7VDD	—	VDD	V

PRELIMINARY
 Notice ; This is not a final specification.
 some parametric limits are subject to change.



DIGITAL ECHO WITH MICROPHONE MIXING CIRCUIT

FUNCTION DESCRIPTION

OPERATION MODE

Operating modes can be set with serial data 16-bits entered at the timing given below.

DATA(pin39) is taken inside at the rising edge of CLOCK(pin38) and the last-packed 16-bits are latched at the raising edge of LATCH(pin37).

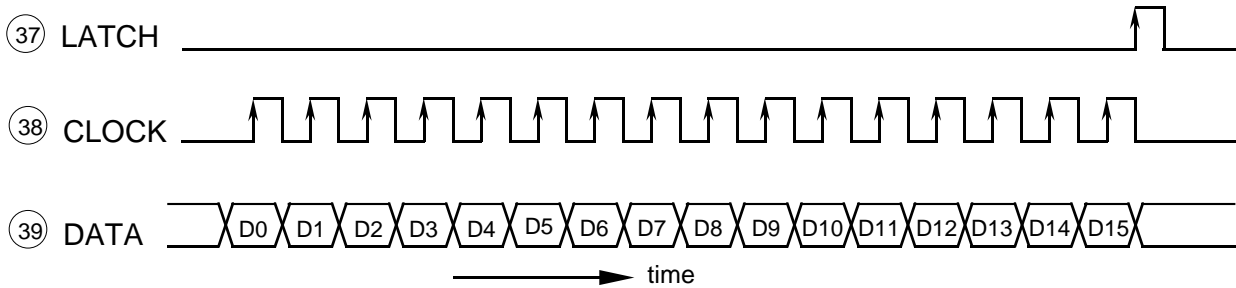

DATA	FUNCTION	Control description	DATA	FUNCTION	Control description	
D0="L"	D0	Digital echo	D0	Echo effect Volume	Sets volume attenuation in 8 steps between +3dB and -∞.	
	D1					
	D2					
	D3	Source selector	Desired audio source operation to each "karaoke" software can be selected by the Source selector. 5 kinds	D4	Echo Feed Back Volume	Sets volume attenuation in 5 steps between -2dB and -∞.
	D4					
	D5					
	D6	Phase shifter surround	Surround is formed with phase shifter to increase the ambience of sound even when karaoke is used.	D7	MIC1 Volume	Sets volume attenuation in 8 steps between 0dB and -∞.
	D7					
	D8	Auto vocal support ON / OFF	If you are in discomfort from unknown song, the vocal of the singer can be output support you. Selector switch for turning on/off of auto vocal support.	D8	MIC2 Volume	Sets volume attenuation in 8 steps between 0dB and -∞.
	D9					
	D10	Line input selector	Selector switch for changing line input of Lch and Rch.	D10		
	D11	MIC SW ON / OFF	Selector switch for turning on/off of microphone signal mixing.	D11		
D12, D13	TEST mode		D12	ADDRESS	Data is taken inside D14=[L], D15=[H], and others cancel.	
D14	ADDRESS	Data is taken inside D14=[L], D15=[H], and others cancel.	D13			
D15					D14	
			D15			

PRELIMINARY
 Notice ; This is not a final specification.
 some parametric limits are subject to change.



DIGITAL ECHO WITH MICROPHONE MIXING CIRCUIT

FUNCTION CONTROL

• DELAY TIME CONTROL

Control Data				Delay time
D0	D3	D2	D1	
L	L	L	—	98.3msec
	L	H	—	131.1msec
	H	L	—	147.5msec
	H	H	—	196.6msec
	H	H	H	Delay off mode

• SOURCE SELECTOR

Control Data				Source select
D0	D6	D5	D4	
L	L	L	L	Lch, monaural
	L	L	H	Rch, monaural
	L	H	—	(L+R) / 2
	H	L	—	Vocal cut
	H	H	—	Stereo

• PHASE SHIFTER SURROUND CONTROL

Control Data			PHASE SHIFTER SURROUND	
D0	D8	D7	Surround SW	Effect
L	L	L	OFF	—
	L	H	ON	LOW
	H	L		MID
	H	H		HIGH

• AUTO VOCAL SUPPORT SWITCH

Control Data		Auto vocal support SW
D0	D9	
L	L	OFF
	H	ON

• SELECT LINE IN SWITCH

Control Data		SELECT LINE IN SW	Remar
D0	D10		
L	L	OFF	Select to LIN1/RIN1
	H	ON	Select to LIN2/RIN2

• MICROPHONE MIXING SWITCH

Control Data		MIC SW	Remar
D0	D11		
L	L	OFF	Microphone mixing OFF
	H	ON	Microphone mixing ON

PRELIMINARY
 Notice ; This is not a final specification.
 some parametric limits are subject to change.



DIGITAL ECHO WITH MICROPHONE MIXING CIRCUIT

VOLUME CONTROL

• Echo effect volume attenuation

Control Data				Attenuation (dB)
D0	D3	D2	D1	
H	L	L	L	+3
	L	L	H	0
	L	H	L	-3
	L	H	H	-6
	H	L	L	-9
	H	L	H	-12
	H	H	L	-15
	H	H	H	-∞

• Echo FEEDBACK volume attenuation

Control Data				Attenuation (dB)
D0	D6	D5	D4	
H	L	L	L	-2
	L	L	H	-3
	L	H	L	-5
	L	H	H	-7
	H	L	L	-∞

• Microphone volume attenuation

Control Data					Attenuation (dB)
D0	D9	D8	D7	MIC1 Volume	
		D12	D11	D10	MIC2 Volume
H	L	L	L		0
	L	L	H		-3
	L	H	L		-6
	L	H	H		-9
	H	L	L		-12
	H	L	H		-15
	H	H	L		-18
	H	H	H		-∞

• ADDRESS CONTROL

Control Data			ADDRESS
D0	D15	D14	
L,H	L	L	Data Cancel
	L	H	Data take inside
	H	L	Data take inside
	H	H	Data Cancel

PRELIMINARY
Notice ; This is not a final specification.
some parametric limits are subject to change.

DIGITAL ECHO WITH MICROPHONE MIXING CIRCUIT

FUNCTION DESCRIPTION

(1) AUTO RESET

Settings are reset automatically when the IC is powered up. The reset state is automatically canceled approximately 150msec after powering up (Vcc=5V and the capacitor connected to pin C=100μF).

By auto reset, operation mode setting become as follows.

- Delay Time Control : 98.3msec
- Phase Shifter Surround Control : OFF
- Select Line IN Switch LIN1,RIN1
- Echo effect Volume : -∞
- Microphone Volume Attenuation : -10dB
- Source Selector : stereo
- Auto Vocal support Switch : OFF
- Microphone Mixing Switch : OFF
- Echo Feed back Volume : -∞

(2) AUTO MUTE FUNCTION

The IC carries out auto mute function at the time of powering up, delay time setting change, in order to suppress shock noise that the digital delay may produce.

- At power up

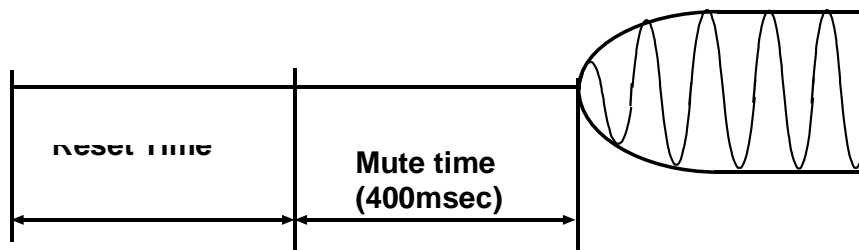

- At delay time setting change
Delay signal before change

Delay signal after change

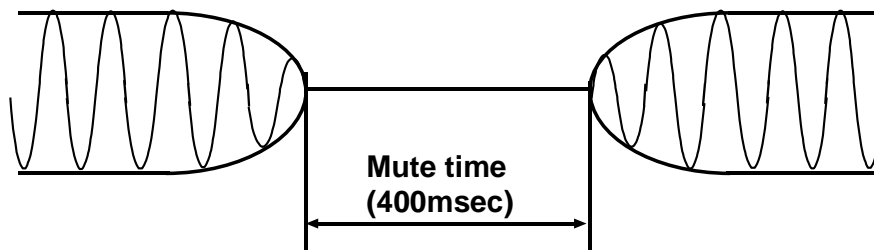

PRELIMINARY
 Notice ; This is not a final specification.
 some parametric limits are subject to change.



DIGITAL ECHO WITH MICROPHONE MIXING CIRCUIT

(3) Clock oscillator circuit

This IC incorporates a current control type clock oscillator circuit in it, thus providing circuit configuration just by connecting an Rc for current control pin 1 (MCLKCONT). Fully internal clock supply prevents occurrence of undesired radiation without affecting any external circuit.

The oscillator frequency fck is following.

$$f_{ck} = 4 \text{ MHz}(R_c=22K\Omega)$$

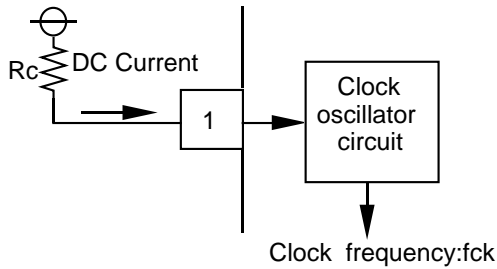

(4) Microphone amplifier

The gain(Gv) and low cut-off frequency(fcl) of microphone amplifier are expressed as follows.

$$G_v = 20 \log \frac{R_1 + 1.5K + 334K}{R_1 + 1.5K} \quad f_{cl} = \frac{1}{2 \cdot (R_1 + 1.5K) \cdot C_1}$$

$$G_v(\text{max}) = 47\text{dB}, f_{cl} = 225\text{Hz}$$

$$R_1 = 0\Omega, C_1 = 0.47\mu\text{F}$$

Assuming $G_v = 37\text{dB}$, $f_{cl} = 220\text{Hz}$, for instance, the constants take the following values.

$$R_1 = 3.3K\Omega, C_1 = 0.15\mu\text{F}$$

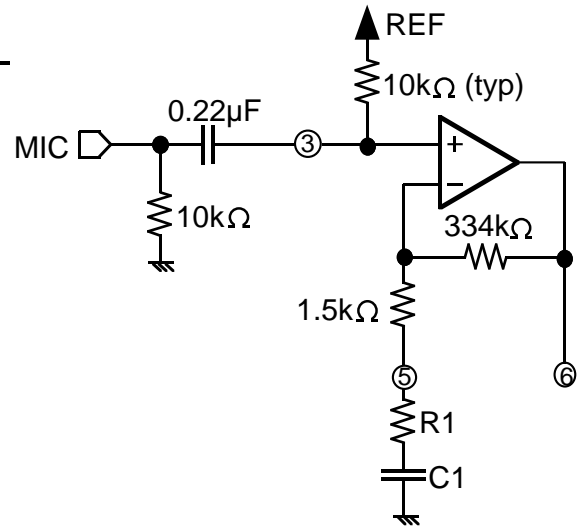

PRELIMINARY
 Notice ; This is not a final specification.
 some parametric limits are subject to change.



DIGITAL ECHO WITH MICROPHONE MIXING CIRCUIT

(5) ALC level diagram

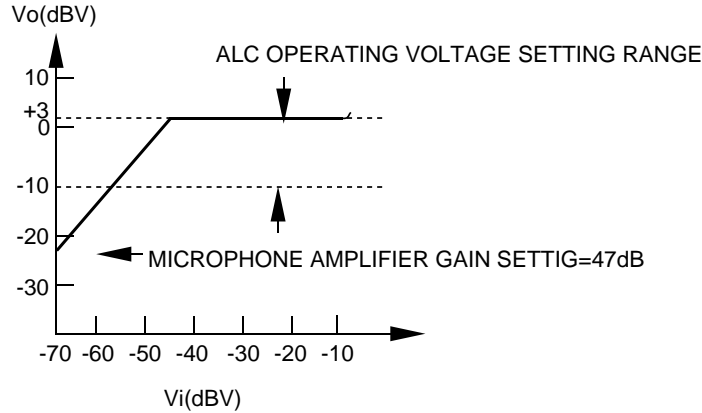

(6) ALC operating voltage setting

ALC operating voltage can be set at a desired value between -10 and +3dBV by varying the DC voltage applied to pin 35 (ALC operating voltage setting terminal).

(Setting method)

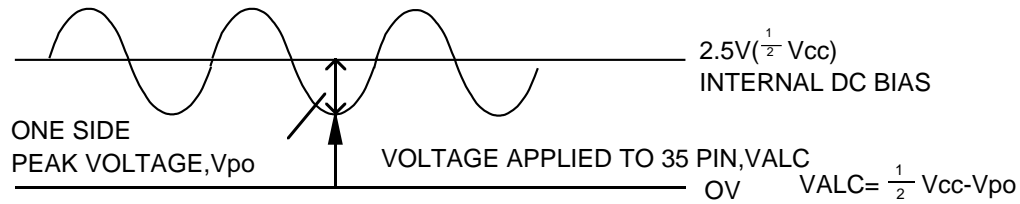

To set ALC operating voltage at -5dB ($V_{cc}=5V$)

$-5dBV = 0.56V_{rms} = 1.59V_{p-p} = 0.8V_{p-o}$

$V_{ALC} = 2.5 - 0.8 = 1.7V$

Since the input impedance at pin 35 is high at $1M\Omega$ or more, it is possible to provide ALC operating voltage by dividing resistance.

When $V_{cc}=5V$

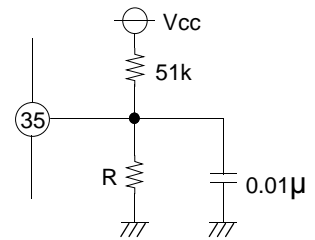

ALC operating voltage (dBV)	Voltage applied to pin 35 V_{ALC} (V)	Resistance $R(\Omega)$
+3	0.50	5.6k
0	1.09	15k
-2	1.38	20k
-4	1.61	24k
-6	1.79	27k
-8	1.94	33k
-10	2.05	36k

PRELIMINARY
 Notice ; This is not a final specification.
 some parametric limits are subject to change.



DIGITAL ECHO WITH MICROPHONE MIXING CIRCUIT

(7) Input and output LPF for the digital echo

The input and output LPF for the digital echo are configured as shown. figure below.

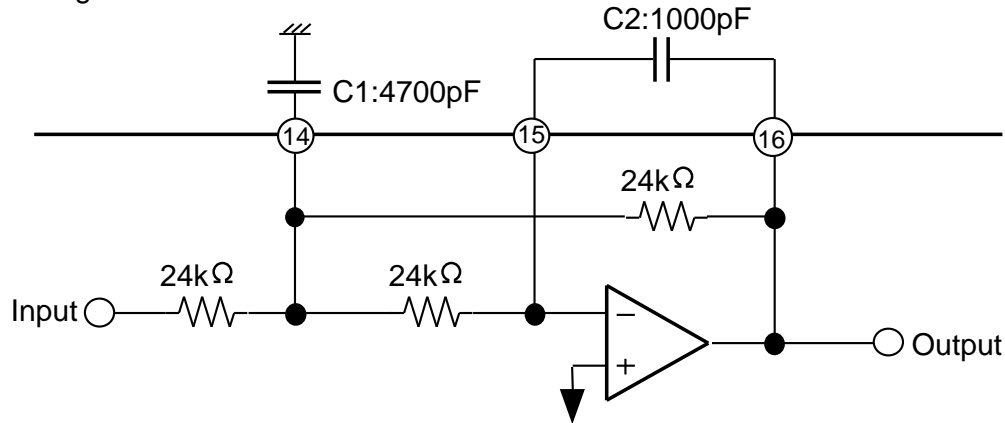

The accuracy of the internal resistance of the IC is approximately ±30%

Cut-off frequency(f_c) is given as follows.

$$f_c = \frac{1}{2\pi \times 24k\Omega \times \sqrt{C1 \times C2}} = \frac{1}{2\pi \times 24k\Omega \times \sqrt{4700pF \times 1000pF}} \approx 3.1KHz$$

Quality factor (Q) is given by the following equation for long echo.

$$Q = \frac{1}{3} \sqrt{\frac{C1}{C2}} \approx 0.72 \quad (\text{Figure of 0.7 is recommended})$$

PRELIMINARY
 Notice ; This is not a final specification.
 some parametric limits are subject to change.



DIGITAL ECHO WITH MICROPHONE MIXING CIRCUIT

(8) Auto vocal support

If you can not continue sing a song, the reference vocal from the source will support you automatically.

Signal Detection	Source selector mode		
	On	Lch monaural	vocal cut
Off	(L+R)/2	(L+R)/2	same as above

The timing of microphone input signal detection

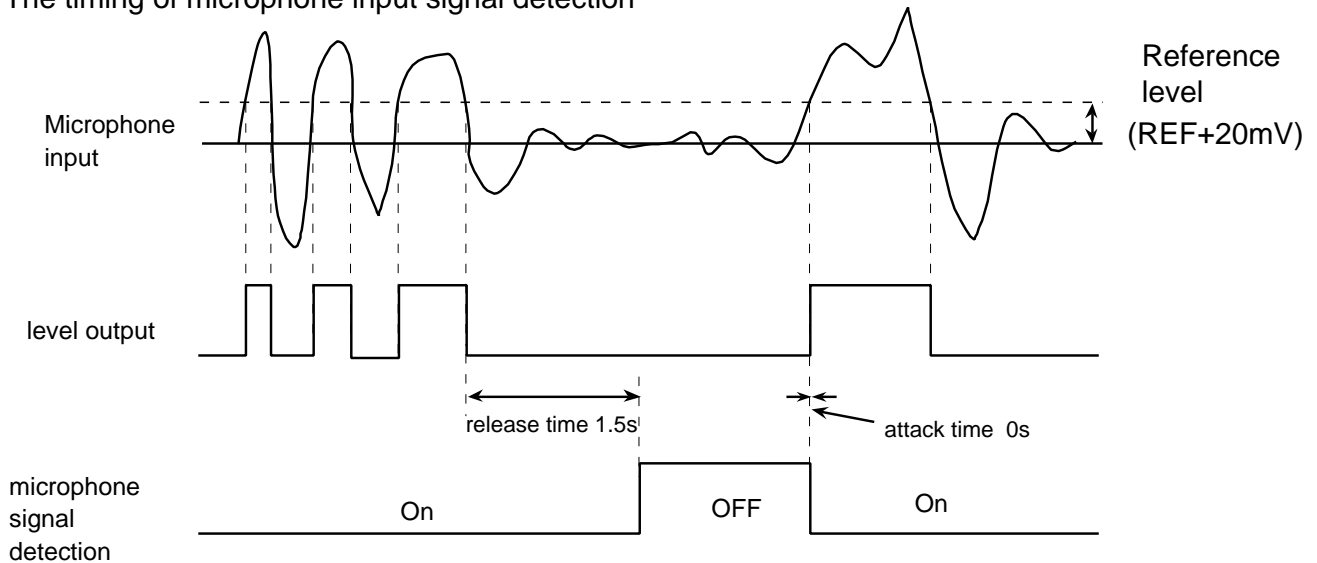

PRELIMINARY
 Notice ; This is not a final specification.
 some parametric limits are subject to change.



DIGITAL ECHO WITH MICROPHONE MIXING CIRCUIT

(9) Vocal cut support

The sound components of the same phase and same sound volume in the L and R channels are attenuated.

This made also allows components with lower frequency than the vocal band to pass through the filter, to compensate insufficient low-frequency sound.

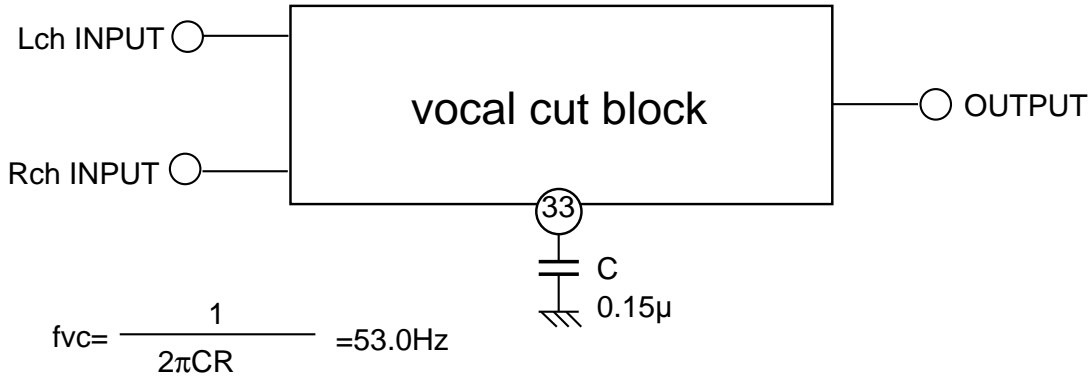

LPF is formed by the internal R (20kΩ) and the external C, where C=0.15μF , cut off frequency is 53Hz.

(10)Following is the phase shifter block, which makes phase surround effect.

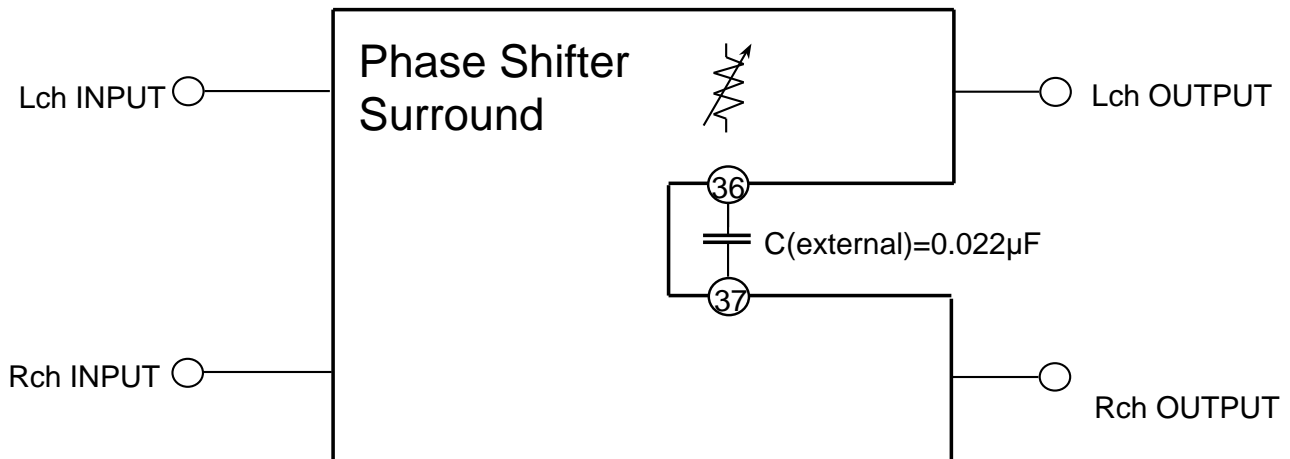

Source selector	Surround
L	Simulated Stereo
R	
(L+R)/2	
Vocal cut	Stereo Surround
Stereo	

PRELIMINARY
 Notice ; This is not a final specification.
 some parametric limits are subject to change.

MITSUBISHI SOUND PROCESSOR ICs

M65853FP



DIGITAL ECHO WITH MICROPHONE MIXING CIRCUIT

APPLICATION EXAMPLE

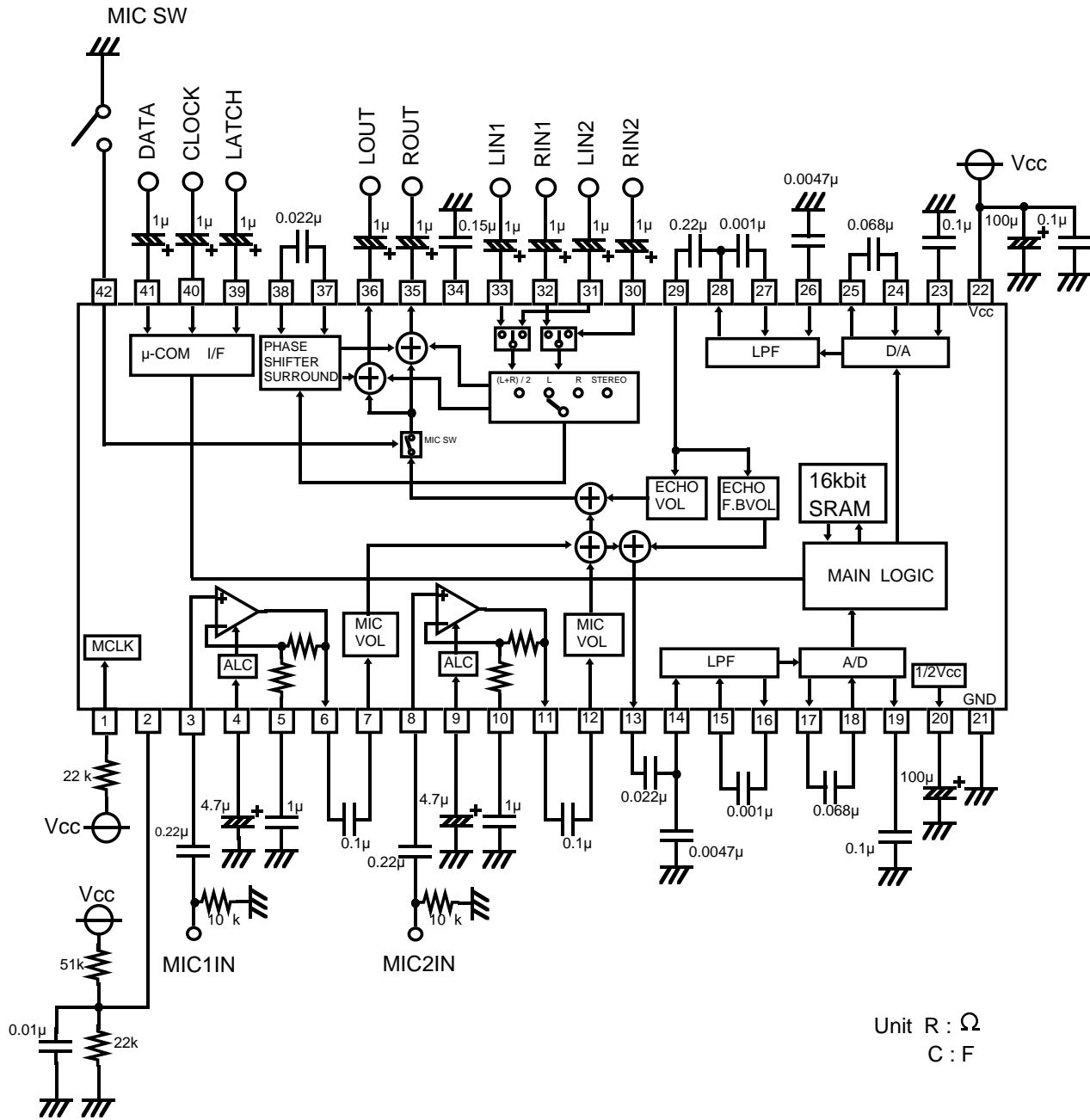

Unit R : Ω
 C : F