

**DESCRIPTION**

The M56758FP is a semiconductor integrated circuit designed for a actuator driver used for MD, CD-audio, etc. This device can function 5-channel-actuators by 1 chip due to include 5 channel BTL drivers.

Sufficient output dynamic range can be obtained by low supply voltage because saturation voltage of power output is low. All channels include level shift circuit in order that output swings most suitably although reference voltage of signal disposal system in each system becomes 1.5V. And, differential PWM control is possible since all channels are composed of Differential input structure. Also, as this device includes general purpose OP amp, it is suited to wide-ranging application. Further more, this device is able to power save since it includes mute circuit.

**FEATURES**

- 3.3V DSP available
- Low saturation voltage.  
(Typical 1.35V at load current 0.5A and no bootstrap condition.)  
Absolute maximum rating of load current: CH1 – 5 500mA  
A bootstrap function is available.
- There are two motor power supplies.  
Vm1 CH1, 2 motor power supply-1  
Vm2 CH3, 4, 5 motor power supply-2
- Built-in OP amp. for Regulator. (Enables Regulator structure by using external PNP Tr. and resistor.)
- Flexible Input amp. setting.  
Enables PWM control.
- Low cross-over distortion.
- Wide supply voltage range. (4.5V – 13.2V)
- Built-in Thermal protection.
- Built-in Mute circuit. (two systems)  
MUTE1: CH1 – 4, MUTE2: CH5

**APPLICATION**

MD, CD-audio, CD-ROM, VCD, DVD etc.

**PIN CONFIGURATION (TOP VIEW)**

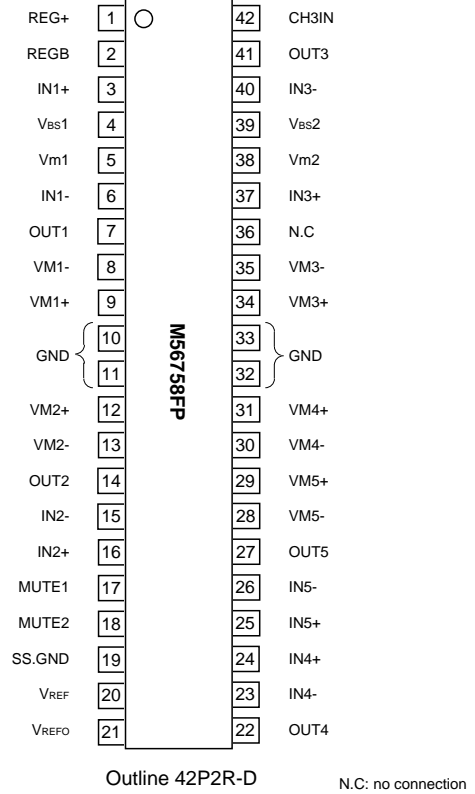

**BLOCK DIAGRAM**

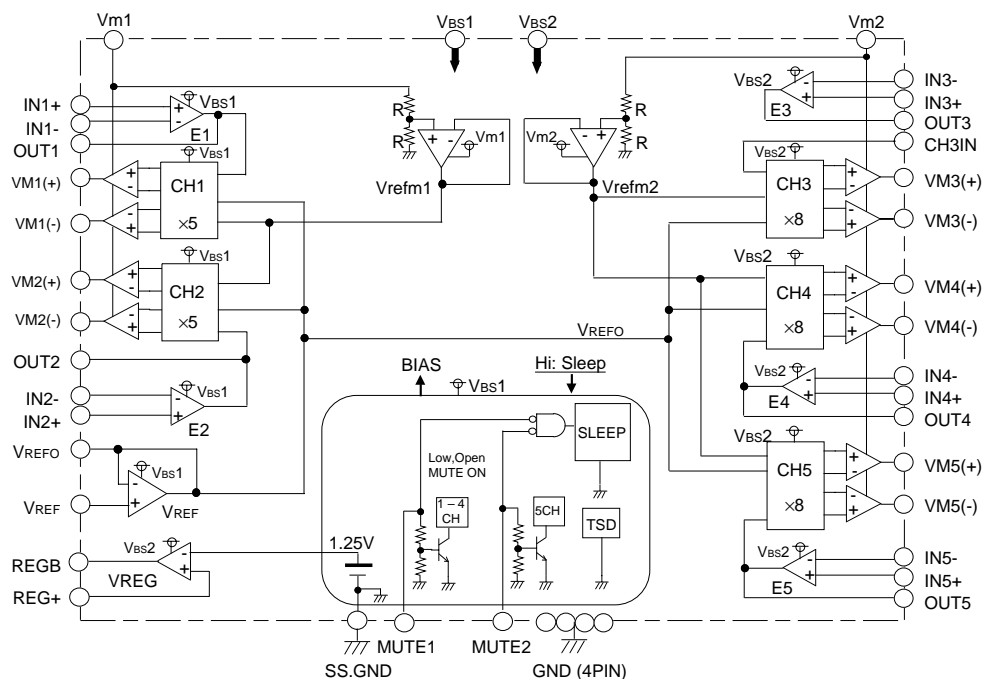

**PIN FUNCTION**

Pin No.	Symbol	Function	Pin No.	Symbol	Function
①	REG+	Regulator voltage setting resistor	④②	CH3IN	CH3 non-inverted input
②	REGB	Regulator PNP base connect	④①	OUT3	E3 amplifier output
③	IN1+	E1 amplifier non-inverted input	④①	IN3-	E3 amplifier inverted input
④	Vbs1	Bootstrap power supply	③⑨	Vbs2	Bootstrap power supply
⑤	Vm1	Motor power supply	③⑧	Vm2	Motor power supply
⑥	IN1-	E1 amplifier inverted input	③⑦	IN3+	E3 amplifier non-inverted input
⑦	OUT1	E1 amplifier output	③⑥	N.C	N.C
⑧	VM1(-)	CH1 inverted output	③⑤	VM3(-)	CH3 inverted output
⑨	VM1(+)	CH1 non-inverted output	③④	VM3(+)	CH3 non-inverted output
⑩, ⑪	GND	Motor GND	③②, ③③	GND	Motor GND
⑫	VM2(+)	CH2 non-inverted output	③①	VM4(+)	CH4 non-inverted output
⑬	VM2(-)	CH2 inverted output	③①	VM4(-)	CH4 inverted output
⑭	OUT2	E2 amplifier output	②⑨	VM5(+)	CH5 non-inverted output
⑮	IN2-	E2 amplifier inverted input	②⑧	VM5(-)	CH5 inverted output
⑯	IN2+	E2 amplifier non-inverted input	②⑦	OUT5	E5 amplifier output
⑰	MUTE1	CH1 – 4 mute	②⑥	IN5-	E5 amplifier inverted input
⑱	MUTE2	CH5 mute	②⑤	IN5+	E5 amplifier non-inverted input
⑲	SS.GND	Small signal GND	②④	IN4+	E4 amplifier non-inverted input
⑳	VREF	Reference voltage input	②③	IN4-	E4 amplifier inverted input
㉑	VREFO	Reference voltage output	②②	OUT4	E4 amplifier output

**ABSOLUTE MAXIMUM RATING (Ta = 25°C)**

Symbol	Parameter	Conditions	Rating	Unit
Vbs	Bootstrap power supply	Vbs power supply	15	V
Vm	Motor power supply	Vm power supply	15	V
Io	Output Current		500	mA
Vin	Maximum input voltage of terminals	③, ⑥, ⑮, ⑯, ⑰, ⑱, ⑳ PIN	0 – Vbs1	V
		①, ⑲, ⑳, ㉑, ㉒, ㉓, ㉔, ㉕, ㉖ PIN	0 – Vbs2	V
Pt	Power dissipation	Free Air	1.2	W
Kθ	Thermal derating	Free Air	9.6	mW/°C
Tj	Junction temperature		150	°C
Topr	Operating temperature		-20 – +75	°C
Tstg	Storage temperature		-40 – +150	°C

**RECOMMENDED OPERATING CONDITIONS**

Symbol	Parameter	Limits			Units
		Min.	Typ.	Max.	
Vm1, Vm2	Motor power supply		5.0		V
Vbs1, Vbs2	Bootstrap power supply		Vm* + 1.0		V

**ELECTRICAL CHARACTERISTICS** (Ta = 25°C, Vbs = Vm = 5V unless otherwise noted)

Symbol	Parameter	Conditions	Limits			Units
			Min.	Typ.	Max.	
Icc1	Supply current - 1	Vbs1, Vbs2, Vm1, Vm2 current	—	35	50	mA
Icc2	Supply current - 2	Vbs1, Vbs2, Vm1, Vm2 current at Sleep Mode (MUTE1 and MUTE2 are inputted to Low).	—	1.3	2.2	mA
Vsat1	Ch1 – 5 Saturation voltage	Top and Bottom saturation voltage. Load current 0.5A and no bootstrap.	—	1.35	1.9	V
Voff1	CH1 output offset voltage	VREFO = OUT1 = 1.5V	-41	—	41	mV
Voff2	CH2 output offset voltage	VREFO = OUT2 = 1.5V	-41	—	41	mV
Voff3	CH3 output offset voltage	VREFO = CH3IN = 1.5V	-47	—	47	mV
Voff4	CH4 output offset voltage	VREFO = OUT4 = 1.5V	-47	—	47	mV
Voff5	CH5 output offset voltage	VREFO = OUT5 = 1.5V	-47	—	47	mV
Gain1	CH1 Voltage Gain between input and output	$\frac{\{VM1(+)-VM1(-)\}}{(OUT1-VREFO)}$	4.5	5	5.5	V/V
Gain2	CH2 Voltage Gain between input and output	$\frac{\{VM2(+)-VM2(-)\}}{(OUT2-VREFO)}$	4.5	5	5.5	V/V

**ELECTRICAL CHARACTERISTICS** (Ta = 25°C, Vbs = Vm = 5V unless otherwise noted)

Symbol	Parameter	Conditions	Limits			Units
			Min.	Typ.	Max.	
Gain3	CH3 Voltage Gain between input and output	$\frac{\{VM3(+)-VM3(-)\}}{(CH3IN-VREFO)}$	7.2	8	8.8	V/V
Gain4	CH4 Voltage Gain between input and output	$\frac{\{VM4(+)-VM4(-)\}}{(OUT4-VREFO)}$	7.2	8	8.8	V/V
Gain5	CH5 Voltage Gain between input and output	$\frac{\{VM5(+)-VM5(-)\}}{(OUT5-VREFO)}$	7.2	8	8.8	V/V
VinE	E1, 2, 3, 4, 5 amplifier input voltage range	E1, E2 amp	0.5	—	Vbs1-2.0	V
		E3, E4, E5 amp	0.5	—	Vbs2-2.0	V
VoutE	E1, 2, 3, 4, 5 amplifier output voltage range	E1, E2 amp (no add)	0.5	—	Vbs1-0.5	V
		E3, E4, E5 amp (no add)	0.5	—	Vbs2-0.5	V
VofE	E1, 2, 3, 4, 5 amplifier offset voltage	Vin = 1.5V (at buffer)	-10	—	+10	mV
linE	E1, 2, 3, 4, 5 amplifier input current	IN+ = IN- = 1.5V	-1.0	-0.05	0	μA
Reg-out	Regulator output voltage range	At Vbs = 7.5V, Regulator voltage setting resistor 10K/30K, connects external PNP.	4.8	5.0	5.2	V
VinVREF	VREF amplifier input voltage range		1.0	—	Vbs1-2.0	V
VofVREF	VREF amplifier offset voltage	Vin = 1.5V ±2mA load	-10	—	+10	mV
linVREF	VREF amplifier input current	VREF = 1.5V	-1.0	-0.05	0	μA
Vmute-on	Mute-on voltage	Mute-on	—	—	0.8	V
Vmute-off	Mute-off voltage	Mute-off	2.0	—	—	V
Imute	Mute terminal input current	Mute terminal input current (at 5V input voltage)	—	170	250	μA

**MUTE Function.**

M56758FP has 2 MUTE terminals and the functions are as follows.

MUTE1 ⑰ pin	MUTE2 ⑱ pin	Power and Control Amp. circuit of CH1 to CH4.	Power and Control Amp. circuit of CH5.	VREF Amp.	VREG Amp.
High	High	ENABLE	ENABLE	ENABLE	ENABLE
Low/Open	High	DISABLE	ENABLE	ENABLE	ENABLE
High	Low/Open	ENABLE	DISABLE	ENABLE	ENABLE
Low/Open	Low/Open	DISABLE	DISABLE	DISABLE	ENABLE

The Sleep Mode means when MUTE1 and MUTE2 are inputted to Low voltage.

**INPUT AND OUTPUT CHARACTERISTICS OF EACH CHANNELS**

**CH1, 2**

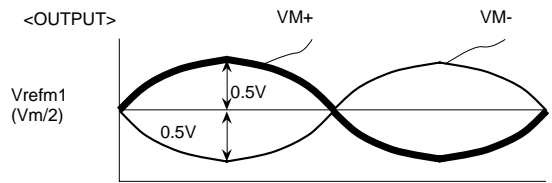
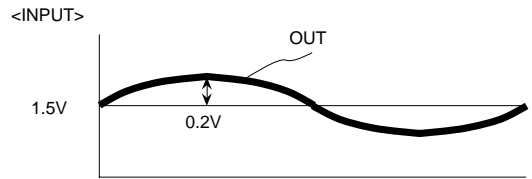
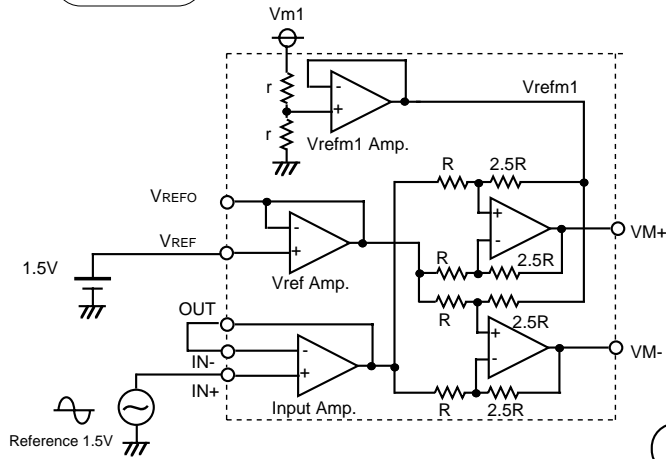

Gain =  $\times 5$

**CH3**

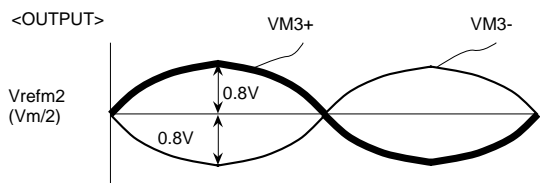
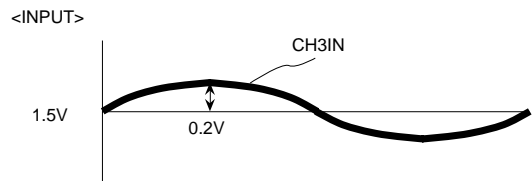
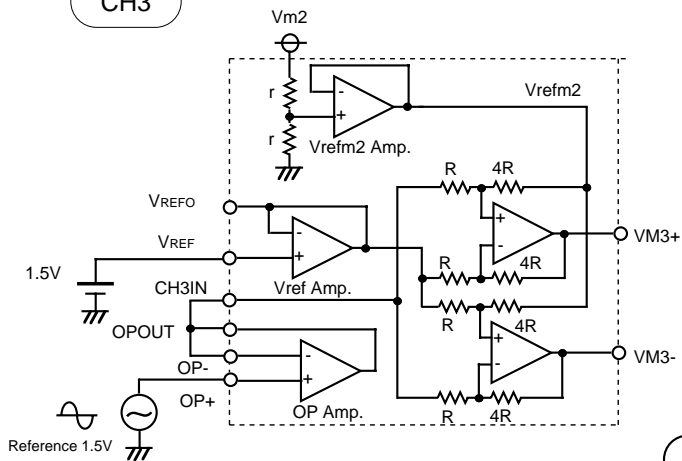

Gain =  $\times 8$

**CH4, 5**

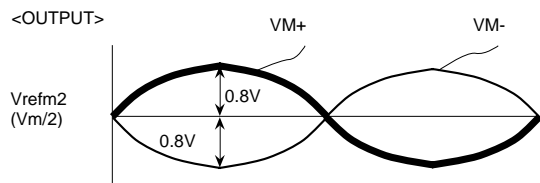
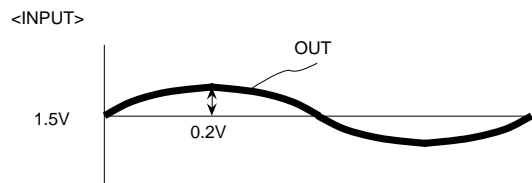
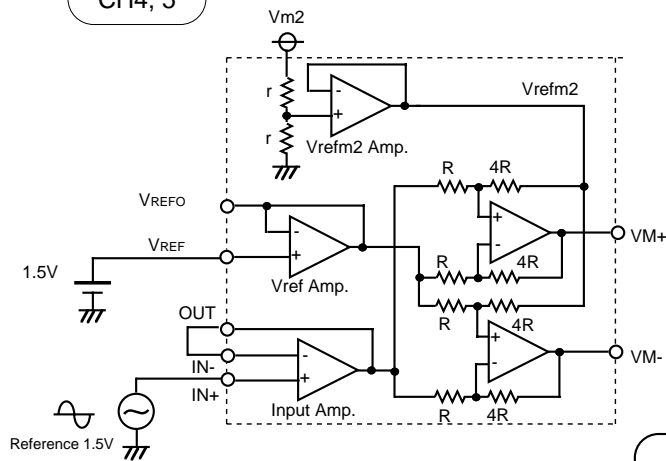

Gain =  $\times 8$

**INPUT AND OUTPUT EQUIVALENT CIRCUIT**

(1) E1, E2 input amplifier input and output equivalent circuit

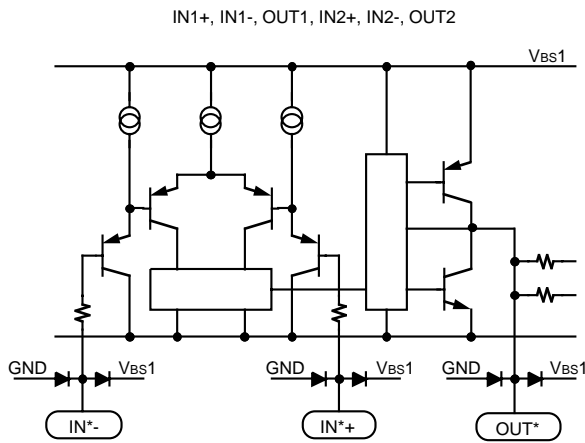

(2) E3, E4, E5 input amplifier input and output equivalent circuit

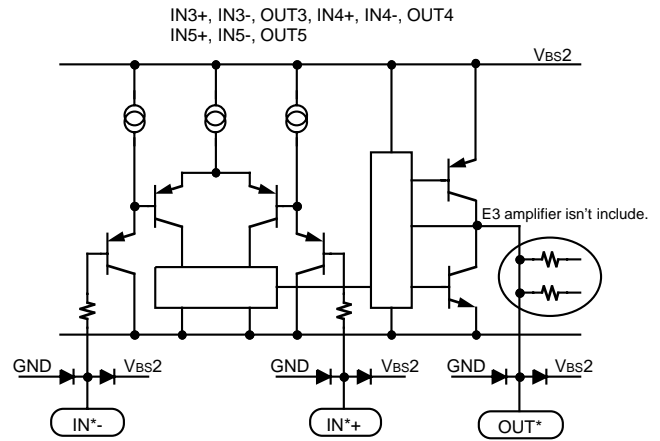

(3) VREF amplifier input and output equivalent circuit

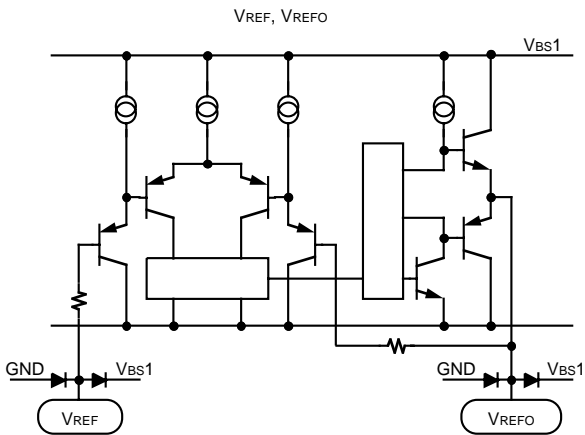

(4) VREG amplifier input and output equivalent circuit

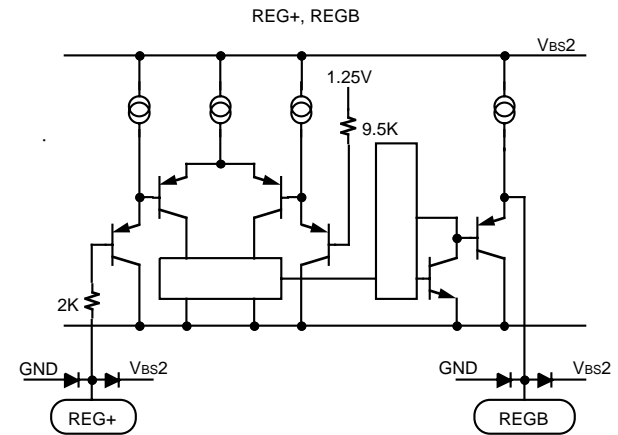

(5) CH3IN input equivalent circuit

Please show the application circuit.  
(about inside circuit structure)

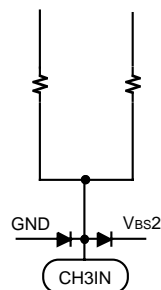

(6) MUTE equivalent circuit

MUTE1, MUTE2

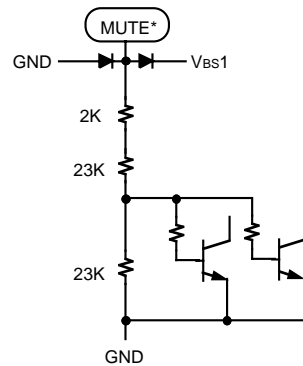

**INPUT AND OUTPUT EQUIVALENT CIRCUIT**

(7) CH1,CH2 power amplifier output equivalent circuit

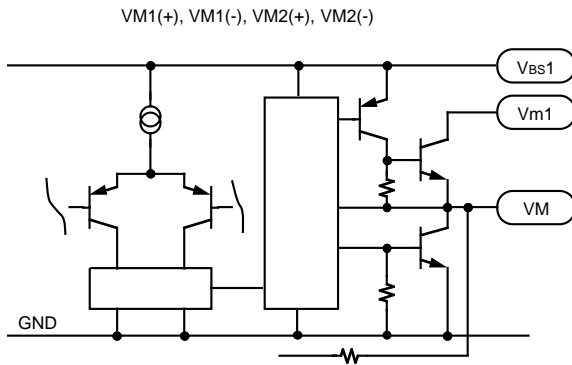

The equivalent circuit of the output stage of power amplifier are shown in (7) and (8).

The power supply of CH1, CH2 are Vm1.

And power supply of CH3, CH4, CH5 are Vm2.

Also, the source side of a power amplifier output is organized by the structure of PNP and NPN.

In case of the CH1 and CH2, a emitta of PNP is connected to Vbs1 and in case of the CH3, CH4 and CH5, it connected to Vbs2 and it can adjust from outside.

[About bootstrap advantage]

Power amplifier output is the preceding structure, and if the high voltage (recommended  $Vm^*+1V$ ) are provided from outside, the output swing can be large value (more than  $Vbs^* = Vm^*$ ).

Please use of this structure at system of many power supply.

If the bootstrap circuit is organized from outside and it provide to  $Vbs^*$ , it will be the same effect.

And the bootstrap can decrease the saturation voltage of power amplifier output, so if it swings motor and actuator, the power dissipation of this device will be decreased.

(8) CH3, CH4, CH5 power amplifier output equivalent circuit

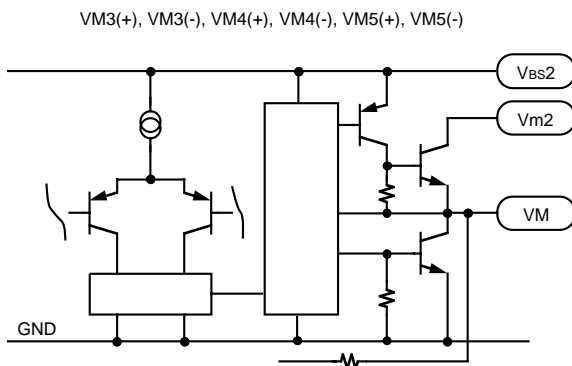

**THERMAL DERATING**

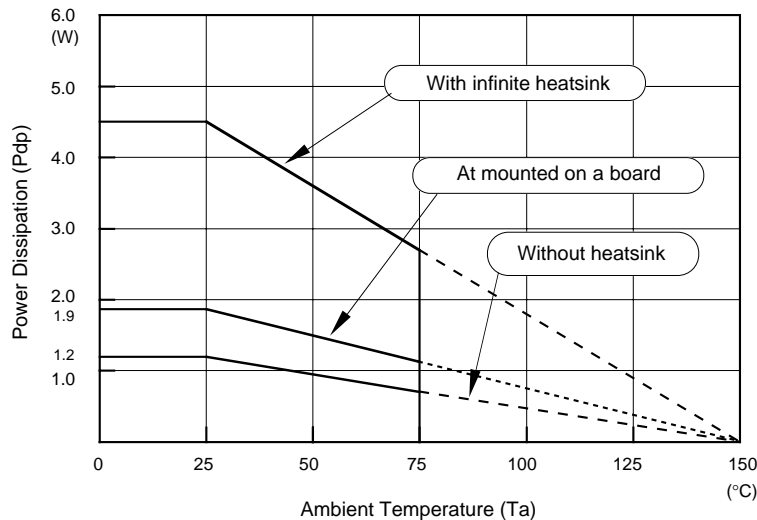

Used board  
Size:190×140mm  
Thickness: 1mm  
Glass epoxy on both sides

**APPLICATION CIRCUIT NO. 1** single input (linear signal) · Direct voltage control

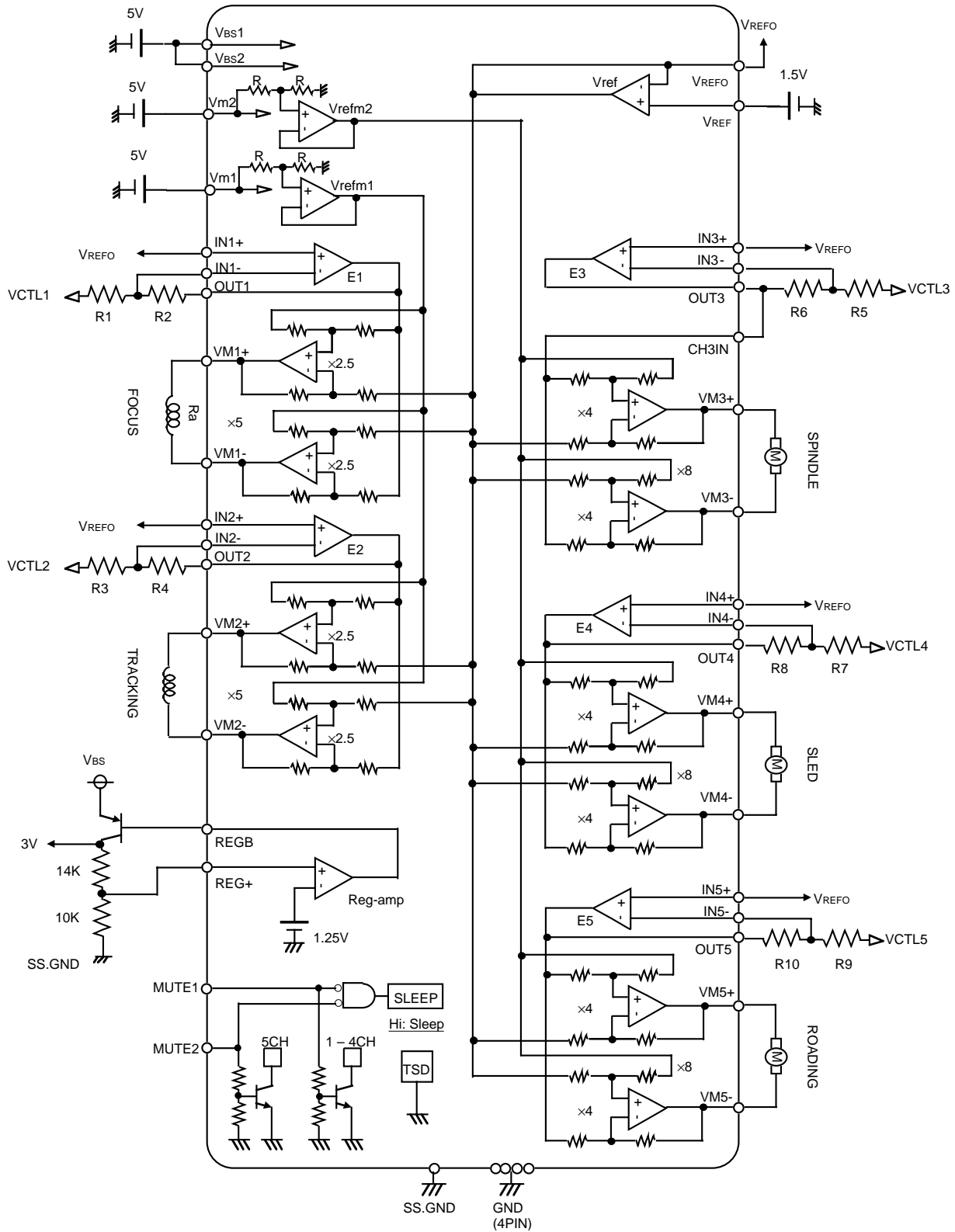



**APPLICATION CIRCUIT NO. 2**

Differential PWM input · Direct voltage control (FOCUS, TRACKING, SPINDLE, SLED, ROADING)

