

# M62475FP

## AUTOMATIC ADJUSTMENT CD PREAMPLIFIER SERVO CONTROLLER

### DESCRIPTION

The M62475FP is an IC that contains preamplifier/servo amplifier necessary for optical pickup servo control for CD player.

This IC also supports automatic adjustment with microcomputer control.

### FEATURES

- Pickup servo control can consist of the M62475FP only
- Supporting 3-beam system
- Built-in serial data command interface with MCU to reduce load on MCU
- Built-in circuit for automatically adjusting tracking balance, tracking/focus gain
- Built-in internal self reset circuit

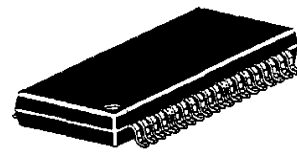

Outline 42P2R-A  
0.8 mm pitch 450 mil SSOP  
(8.4 mmX17.5 mmX2.0 mm)

### RECOMMENDED OPERATING CONDITIONS

Supply voltage range..... Vcc=4.5 to 5.5V  
Rated supply voltage..... Vcc=5V

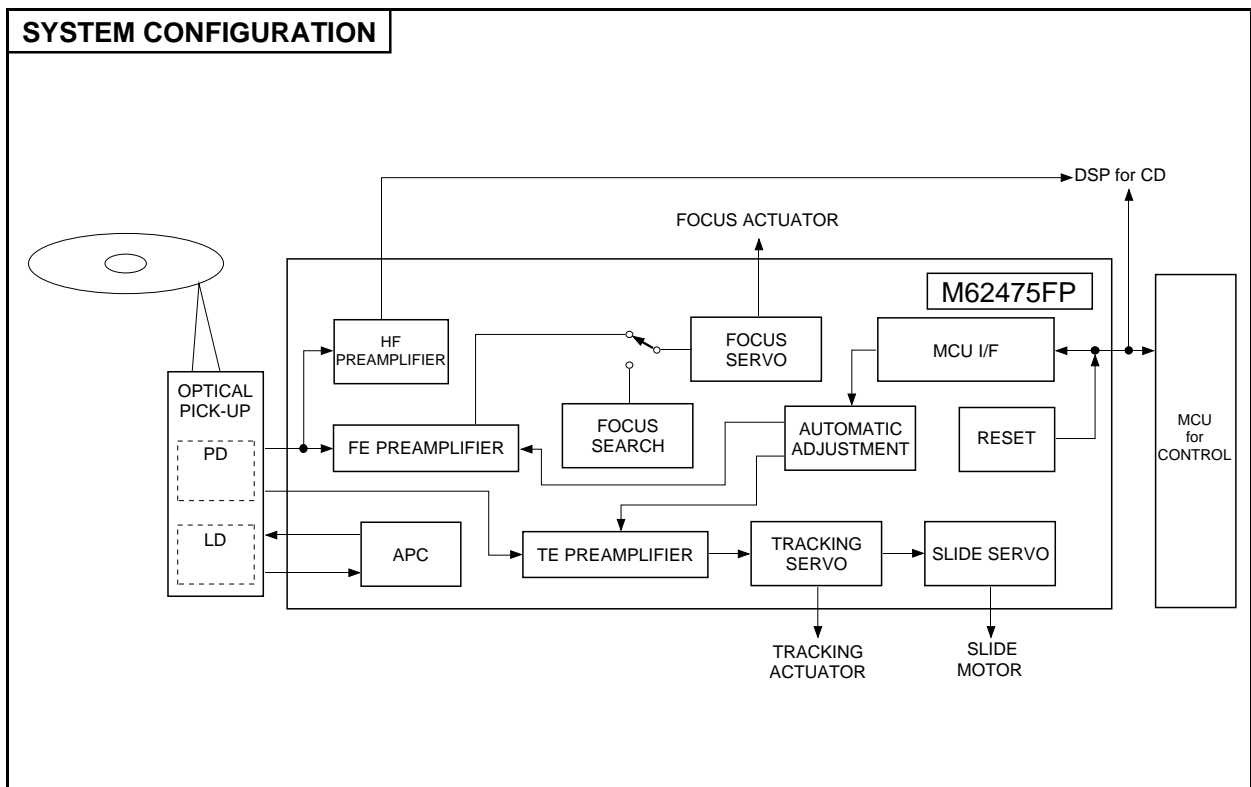

**AUTOMATIC ADJUSTMENT CD PREAMPLIFIER SERVO CONTROLLER**

**PIN CONFIGURATION (TOP VIEW)**

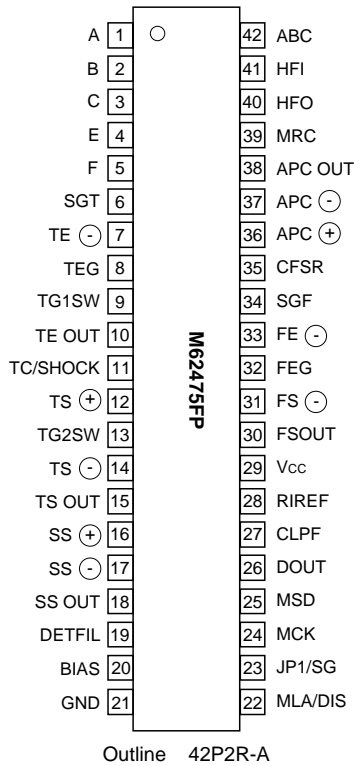

**BUILT-IN FUNCTION**

- IV amplifier
- HF amplifier:HF (High Frequency Amp.)
- Focus Error Amplifier:FE (Focus Error Amp.)
- Focus Servo Amplifier:FS (Focus Servo Amp.)
- Tracking Error Amplifier:TE (Tracking Error Amp.)
- Tracking Servo Amplifier:TS (Tracking Servo Amp.)
- Sledge Motor Servo Amplifier:SS (Sledge Servo Amp.)
- Switching Circuit for Jump Brake:  
TG1SW, TG2SW (Tracking Gain SW)  
JF SW, JR SW (Jump Forward/Reverse SW)  
SF SW, SR SW (Sledge Forward/Reverse SW)
- Focus Search Circuit  
Search Signal Generator  
FSOK Detector
- Track Cross Detector: TC Det (Track Cross Detector)
- Shock Detector: SC Det (Shock Detector)
- Logic Controller:  
Serial Data Command Interface  
Jump, Brake, Focus Search Control  
Adjustment Control
- Vcc/2 generation circuit
- Auto Laser Power Control: APC (Automatic laser Power Control)
- HF Bottom Level Detector
- MR Detector
- Automatic Adjustment Circuit  
Tracking balance adjustment circuit  
Tracking gain adjustment circuit  
Focus gain adjustment circuit  
Gain adjustment signal generation and phase detection circuit

**IC INTERNAL BLOCK DIAGRAM**

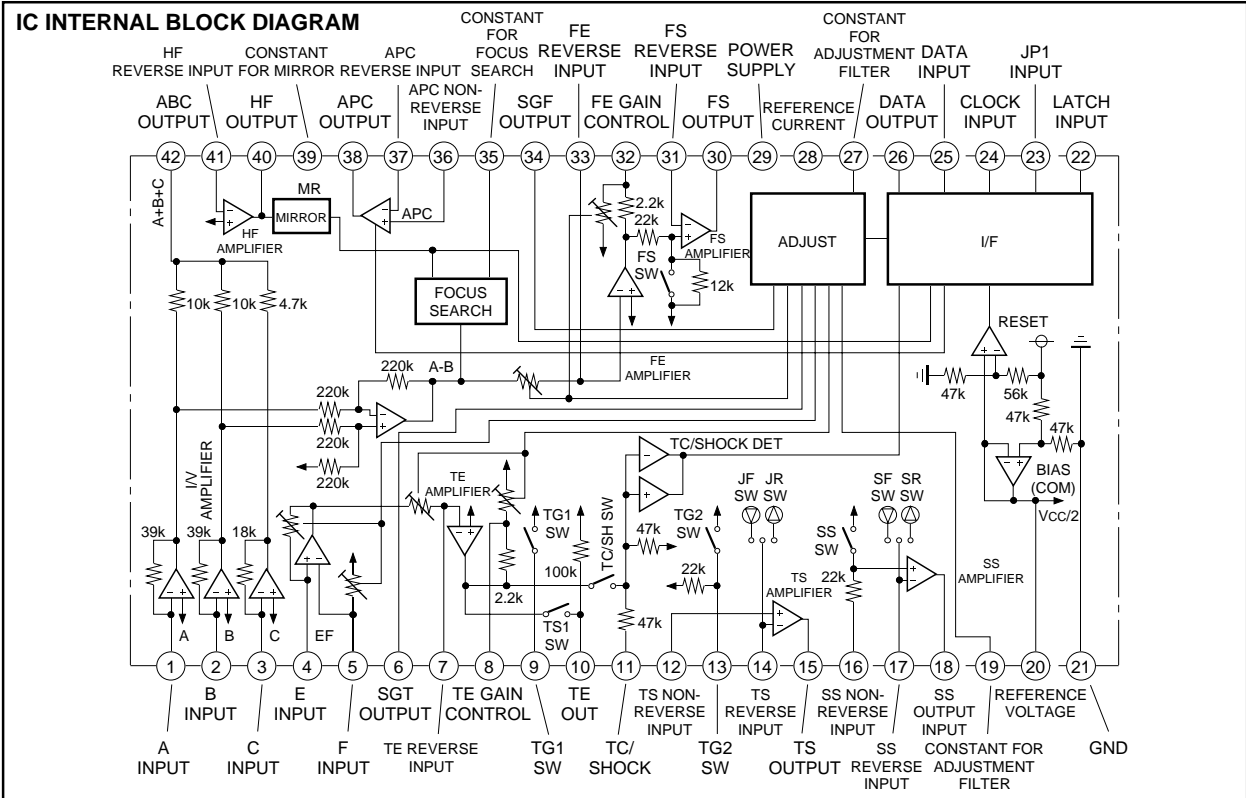

**AUTOMATIC ADJUSTMENT CD PREAMPLIFIER SERVO CONTROLLER**

**PIN DESCRIPTION**

Pin No.	Symbol	Function
①	A	I-V amplifier A input
②	B	I-V amplifier B input
③	C	I-V amplifier C input
④	E	I-V amplifier E input
⑤	F	I-V amplifier F input
⑥	SGT	Tracking servo signal output
⑦	TE ⊖	TE amplifier reverse input
⑧	TEG	TE amplifier gain control
⑨	TG1 SW	Tracking gain select switch 1
⑩	TE OUT	TE amplifier output
⑪	TC/SHOCK	Tracking cross/shock detector input
⑫	TS ⊕	TS amplifier non-reverse input
⑬	TG2 SW	Tracking gain select switch 2
⑭	TS ⊖	TS amplifier reverse input
⑮	TS OUT	TS amplifier output
⑯	SS ⊕	SS non-reverse input
⑰	SS ⊖	SS amplifier reverse input
⑱	SS OUT	SS output
⑲	DET FIL	Detector filter for gain adjustment
⑳	BIAS	Vcc/2 voltage output
㉑	GND	Ground
㉒	MLA/DIS	Latch of serial data from microcomputer to servo IC/discharge of LPF for automatic adjustment
㉓	JP1/SG	Control signal of 1 track jump brake pulse/Input of gain adjustment clock
㉔	MCK	Serial data transfer clock from microcomputer to servo IC
㉕	MSD	Microcomputer serial data
㉖	DOUT	Output of data to microcomputer
㉗	CLPF	Connects capacitor for determining the constant for automatic adjustment LPF
㉘	IREF	Connects resistance for setting current value of reference supply current
㉙	Vcc	Power supply
㉚	FSOUT	FS amplifier output
㉛	FS ⊖	FS amplifier reverse input
㉜	FEG	FE amplifier gain control
㉝	FE ⊖	FE amplifier reverse input
㉞	SGF	Focus servo signal output
㉟	CFSR	Connects the capacitor to determine the constant for focus search waveform
㊱	APC ⊕	APC amplifier non-reverse input
㊲	APC ⊖	APC amplifier reverse input
㊳	APC OUT	APC amplifier output
㊴	MRC	Constant for mirror
㊵	HF OUT	HF amplifier output
㊶	HF ⊖	HF amplifier reverse input
㊷	ABC	IV amplifier (A+B+C) output

**ABSOLUTE MAXIMUM RATINGS** (Ta=25°C, unless otherwise noted)

Symbol	Parameter	Ratings	Unit
Vcc	Supply voltage	5	V
Vi	Input voltage	0 to Vcc	V
Pd	Power dissipation	750	mW
Kθ	Thermal derating (Ta 25°C)	7.5	mW/°C
Topr	Operating ambient temperature	-20 to +75	°C
Tstg	Storage temperature	-40 to +125	°C

**AUTOMATIC ADJUSTMENT CD PREAMPLIFIER SERVO CONTROLLER**

**ELECTRICAL CHARACTERISTICS** (Ta=25°C, Vcc=5V, f=1kHz, CBA=100, unless otherwise noted)

Block	Symbol	Parameter	Test conditions	Limits			Unit
				Min.	Typ.	Max.	
—	Icc	Circuit current	With no signal provided, after reset	20.0	30.0	40.0	mA
	VREF	Reference voltage	With no signal provided, after reset	2.4	2.5	2.6	V
HF	GVHFAB	Gain (input A/B)	f=500kHz, Vi=0.5Vp-p	3.1	5.1	7.1	dB
	GVHFC	Gain (input C)	f=500kHz, Vi=0.5Vp-p	9.7	11.7	13.7	dB
	fHF	Frequency characteristics	Vi=0.5Vp-p	1.4	2.0	—	MHz
	VHHF	Output voltage "H"	Vi=4.0V	3.5	4.0	—	V
	VLHF	Output voltage "L"	Vi=1.0V	—	1.0	1.5	V
	VOSHF	Output offset	VREF reference	-60	0	+60	mV
FS OK	VTFK	FSOK level	VREF reference	-0.22	-0.16	-0.10	V
MR	RMN	Ratio (normal)	"Shock" mode	0.35	0.45	0.55	—
	RMJ	Ratio (jump)	"Brake" mode	0.46	0.56	0.66	—
	fMR	Frequency characteristics	"Shock" mode	20	30	—	kHz
APC	GVAP	Gain	Vi=20mVrms	25	27	29	dB
	ATTAP	Attenuation (APC OFF)	Comparison with GVAP	60	—	—	dB
	VHAP	Output voltage "H"	Vi=4.0V	4.0	—	—	V
	VLAP	Output voltage "L"	Vi=1.0V	—	—	1.0	V
	VOSAP	Input offset	VREF reference	-10	0	+10	mV
FE	GVFE	Gain	Vi=10mVrms	2	4	6	dB
	VHFE	Output voltage "H"	Vi=4.0V	3.5	4.0	—	V
	VLFE	Output voltage "L"	Vi=1.0V	—	1.0	1.5	V
	BALFE	Balance	Comparison with GVFE	-2	0	+2	%
FS	GVFS	Gain	Vi=50mVrms	19.3	21.3	23.3	dB
	ATTFS	Attenuation (FS OFF)	Comparison with GVFS	60	—	—	dB
	VHFS	Output voltage "H"	Vi=4.0V	3.5	4.0	—	V
	VLFS	Output voltage "L"	Vi=1.0V	—	1.0	1.5	V
	VOSFS	Output offset	VREF reference	-50	0	+50	mV
FSR	VFSR (+)	Focus search (+) voltage	VREF reference, pin (35)	+0.6	+0.8	+1.0	V
	VFSR (-)	Focus search (-) voltage	VREF reference, pin (35)	-1.0	-0.8	-0.6	V
	VFZC	Focus zero cross voltage	VREF reference	-0.22	-0.16	-0.10	V
TE	GVTE	Gain	Vi=50mVrms	7.0	9.0	11.0	dB
	VHTE	Output voltage "H"	Vi=4.0V	3.5	4.0	—	V
	VLTE	Output voltage "L"	Vi=1.0V	—	1.0	1.5	V
	VOSTE	Output offset	VREF reference	-25	0	+25	mV
	BALTE	Track balance	VREF reference	-1.5	+1.5	+4.5	%
TS	GVTS	Gain	Vi=50mVrms	-0.6	1.4	3.4	dB
	ATTTS	Attenuation (TS OFF)	Comparison with GVTS	60	—	—	dB
	VHTS	Output voltage "H"	Vi=4.0V	3.5	4.0	—	V
	VLTS	Output voltage "L"	Vi=1.0V	—	1.0	1.5	V
	VOSTS	Output offset	VREF reference	-25	0	+25	mV

AUTOMATIC ADJUSTMENT CD PREAMPLIFIER SERVO CONTROLLER

ELECTRICAL CHARACTERISTICS (Ta=25°C, Vcc=5V, f=1kHz, CBA=100, unless otherwise noted) (cont.)

Block	Symbol	Parameter	Test conditions	Limits			Unit
				Min.	Typ.	Max.	
—	V <sub>JF</sub>	Jump voltage (forward)	"JF" mode, VREF reference	+0.10	+0.15	+0.20	V
	V <sub>JR</sub>	Jump voltage (reverse)	"JR" mode, VREF reference	-0.20	-0.15	-0.10	V
TC	V <sub>TC</sub> ⊕	Track cross ⊕ voltage	"Brake" mode, VREF reference	+42.5	+62.5	+82.5	mV
	V <sub>TC</sub> ⊖	Track cross ⊖ voltage	"Brake" mode, VREF reference	-42.5	-62.5	82.5	mV
SHOCK	V <sub>SH</sub> ⊕	Shock ⊕ voltage	"Shock" mode, VREF reference	+110	+140	+170	mV
	V <sub>SH</sub> ⊖	Shock ⊖ voltage	"Shock" mode, VREF reference	-170	-140	-110	mV
TG	ATG1ON	Attenuation (TG1 ON)	"Shock" mode, VREF reference	10	20	—	dB
	ATG1OFF	Attenuation (TG1 OFF)	"Shock" mode, VREF reference	0	—	2	dB
	ATG2ON	Attenuation (TG2 ON)	"Shock" mode, VREF reference	10	20	—	dB
	ATG2OFF	Attenuation (TG2 OFF)	"Shock" mode, VREF reference	0	—	2	dB
SS	G <sub>VTS</sub>	Gain	Vi=50mVrms	10	12	14	dB
	A <sub>TSS</sub>	Attenuation (SS OFF)	Comparison with G <sub>vss</sub>	60	—	—	dB
	V <sub>HSS</sub>	Output voltage "H"	Vi=4.0V	3.5	4.0	—	V
	V <sub>LSS</sub>	Output voltage "L"	Vi=1.0V	—	1.0	1.5	V
	V <sub>OSSS</sub>	Output offset voltage	VREF reference	-25	0	+25	mV
	V <sub>SF</sub>	Slide voltage (forward)	"SF" mode, VREF reference	+0.65	+0.95	+1.25	V
RESET	V <sub>SR</sub>	Slide voltage (reverse)	"SR" mode, VREF reference	-1.25	-0.95	-0.65	V
	V <sub>RST</sub>	Reset voltage	Pin (20)	2.1	2.3	2.5	V
ADJ	V <sub>ORST</sub>	Output voltage	Pin (36), after RESET	3.5	4.5	—	V
	G <sub>VFE(max)</sub>	Max. gain (FE)	Focus gain" mode CBA=111	3.5	5.5	7.5	dB
	G <sub>VFE(min)</sub>	Min. gain (FE)	"Focus gain" mode CBA=000	-3.5	-1.5	0.5	dB
	G <sub>VTE(max)</sub>	Max. gain (TE)	"Track gain" mode CBA=111	19	21	23	dB
	G <sub>VTE(min)</sub>	Min. gain (TE)	"Track gain" mode CBA=000	12	14	16	dB
	B <sub>ALTE(max)</sub>	Max. balance (TE)	"Track balance" mode CBA=111	8.0	11.0	14.0	%
	B <sub>ALTE(min)</sub>	Min. balance (TE)	"Track balance" mode CBA=000	-12.8	-9.8	-6.8	%
	V <sub>PhFE</sub> ⊕	Phase difference ⊕ voltage	"Focus gain" mode phase difference (90+30)°	3.1	3.3	3.5	V
	V <sub>PhFE</sub> ⊖	Phase difference ⊖ voltage	"Focus gain" mode phase difference (90-30)°	1.5	1.7	1.9	V
	V <sub>PhTE</sub> ⊕	Phase difference ⊕ voltage	"Track gain" mode phase difference (90+30)°	3.1	3.3	3.5	V
	V <sub>PhTE</sub> ⊖	Phase difference ⊖ voltage	"Track gain" mode phase difference (90-30)°	1.5	1.7	1.9	V
	V <sub>BAL</sub> ⊕	Balance ⊕ voltage	"Track balance" mode +0.5V offset	2.8	3.0	3.2	V
	V <sub>BAL</sub> ⊖	Balance ⊖ voltage	"Track balance" mode -0.5V offset	1.8	2.0	2.2	V
	CMP	G <sub>LADJ</sub>	Phase detection exit low pass filter gain	C (Pin (19))=680pF	-5	-3	-1
V <sub>thc</sub> ⊕		Comparator level ⊕	VREF reference	0	—	+50	mV
V <sub>thc</sub> ⊖		Comparator level ⊖	VREF reference	-50	—	0	mV
G <sub>LC</sub>		Low pass filter gain	C (Pin (27))=2.2nF	-5	-3	-1	dB
SG	V <sub>SGF</sub> ⊕	SGF ⊕ output voltage	Pin (34), VREF reference	0.6	0.7	0.8	V
	V <sub>SGF</sub> ⊖	SGF ⊖ output voltage	Pin (34), VREF reference	-0.8	-0.7	-0.6	V
	V <sub>SGT</sub> ⊕	SGT ⊕ output voltage	Pin (6), VREF reference	0.6	0.7	0.8	V
	V <sub>SGT</sub> ⊖	SGT ⊖ output voltage	Pin (6), VREF reference	-0.8	-0.7	-0.6	V

**AUTOMATIC ADJUSTMENT CD PREAMPLIFIER SERVO CONTROLLER**

**FUNCTION DESCRIPTION**

**Setting Built-in Constant Current Source Current Value**

The current value of Tracking Servo (TS) and Sledge Servo (SS) constant current can be set with resistance value Rx connected between pin ⑳ and Vcc.

If the absolute values for TS and SS constant source current values are assumed to be I (JF, JR) and I (SF, SR), respectively, they are set as follows.

$$I_{(JF, JR)} = \frac{1}{8} \cdot \frac{V_{CC} - V_{(28)}}{R_x}$$

$$I_{(SF, SR)} = \frac{1}{4} \cdot \frac{V_{CC} - V_{(28)}}{R_x}$$

Where, V<sub>(28)</sub> is the voltage of pin ⑳. If the voltage of pin ㉑ (GND) is assumed to be V<sub>(21)</sub>, V<sub>(28)</sub> can be found by the following formula.

$$V_{(28)} = V_{(21)} + V_{BE} \quad (V_{BE} \approx 0.7V \text{ standard})$$

**CONSTANT CURRENT SOURCE BLOCK DIAGRAM**

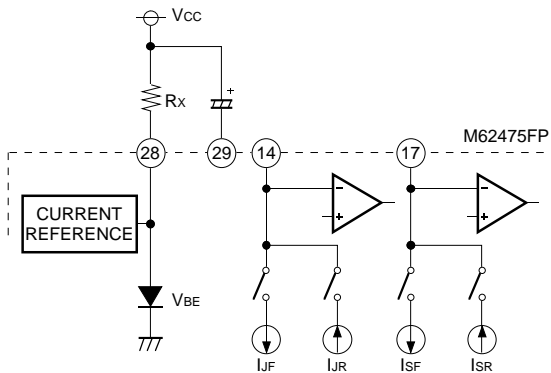

**FSR Detector**

When the focus search is performed, the focus search direction is automatically switched.

The focus search always starts from the (+) side. The polarity (+ / - direction) internal logic signal of the focus search voltage is used for control and switching.

FZC detection is effective only in a direction.

**EQUIVALENT CIRCUIT**

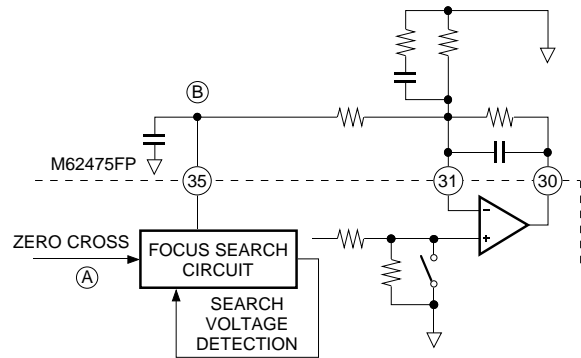

**FZC OPERATION TIMING CHART**

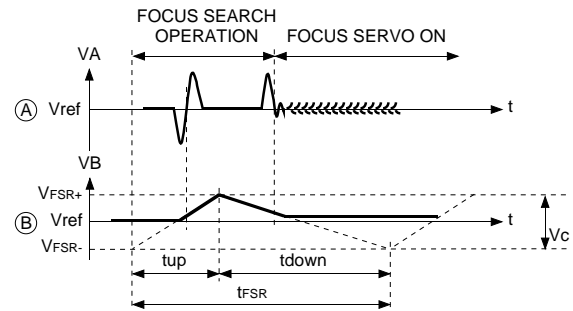

**Setting FSR time tFSR (CFSR setting)**

$$t_{FSR} = \frac{C_{FSR}}{I_{FSR}}$$

CFSR: CFSR pin 35 external capacitor

I<sub>FSR</sub>: Focus search current

At time of rising: 110μA

At time of falling: 60μA

**FSR Vth± Voltage setting**

V<sub>th+</sub>: V<sub>ref</sub> + 0.7V

V<sub>th-</sub>: V<sub>ref</sub> - 0.7V

## AUTOMATIC ADJUSTMENT CD PREAMPLIFIER SERVO CONTROLLER

**AUTOMATIC ADJUSTMENT FUNCTION**

The IC is capable of automatically adjusting the three places of tracking balance, tracking gain and focus gain.

**TRACKING BALANCE ADJUSTMENT**

The input resistance of the I/V conversion amplifier connected to E and F pickups and the 8-step adjustment resistance built in a feedback resistance are switched for the adjustment. The adjustment precision is approximately 3% by the step.

The automatic adjustment operation enters an oscillation signal from the automatic adjustment signal generator of MCU into a servo loop to forcibly make the beam cross the track. When this is the case, the output voltage of I/V conversion amplifier is integrated. If the E and F output signals are well balanced and are the same, an error voltage is not generated in the output voltage after this integration and a reference voltage is obtained. If they are not balanced, a voltage of a DC component is generated. The result of having compared this output voltage and the reference voltage is converted into a logical level and is then output to the monitor terminal. The MCU is used for control and the result is judged. According to the result, the adjustment resistance of the I/V conversion amplifier is sequentially switched step by step for the adjustment in the direction of reversing the current logical result. At the time when the result has been reversed, the error is judged to be put within a one-step error and the adjustment is complete.

**TRACKING FOCUS GAIN ADJUSTMENT**

The input resistance of the tracking focus error amplifier and the 8-step adjustment resistance built in a feedback resistance are switched for the adjustment. The adjustment precision is approximately 1 dB by the step.

The adjustment operation enters an oscillation signal with the output gain of -3 dB in a servo loop from the automatic adjustment signal generator of MCU into a servo loop to forcibly generate a gap in the track and focus. A waveform adjusted signal of the generated tracking focus error signal and the MCU oscillation signal are collated with each other with respect to the phase and is then integrated to convert the phase difference into the voltage. The result of having compared this output voltage and the reference voltage is converted into a logical level and is then output to the monitor terminal. The MCU is used for control and the result is judged. According to the result, the input resistance of the amplifier is sequentially switched step by step in feedback resistance for the adjustment in the direction of reversing the current logical result. At the time when the result has been reversed, the error is judged to be put within a one-step error and the adjustment is complete.

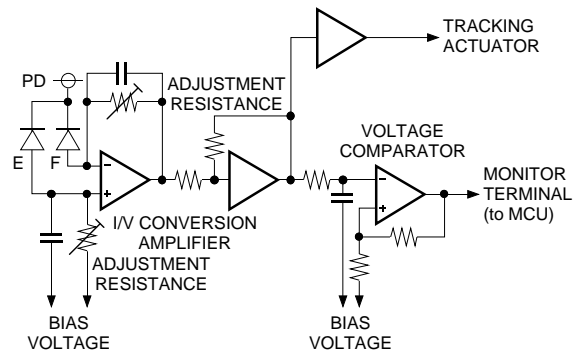
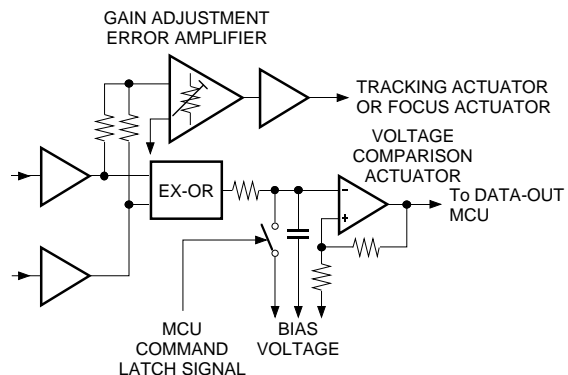
**EQUIVALENT CIRCUIT (Tracking Balance)****EQUIVALENT CIRCUIT (Tracking Focus Gain)**

**AUTOMATIC ADJUSTMENT CD PREAMPLIFIER SERVO CONTROLLER**

**AUTOMATIC ADJUSTMENT FLOWCHART**

**BASIC ROUTINE**

Serial data command: XXOOOCBA (XX is specified according to the adjustment command.)

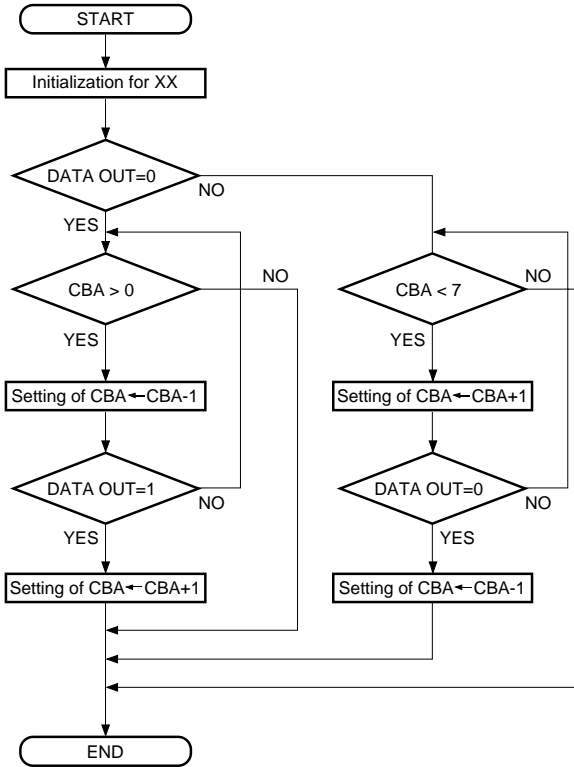

**AUTOMATIC ADJUSTMENT EXAMPLE**

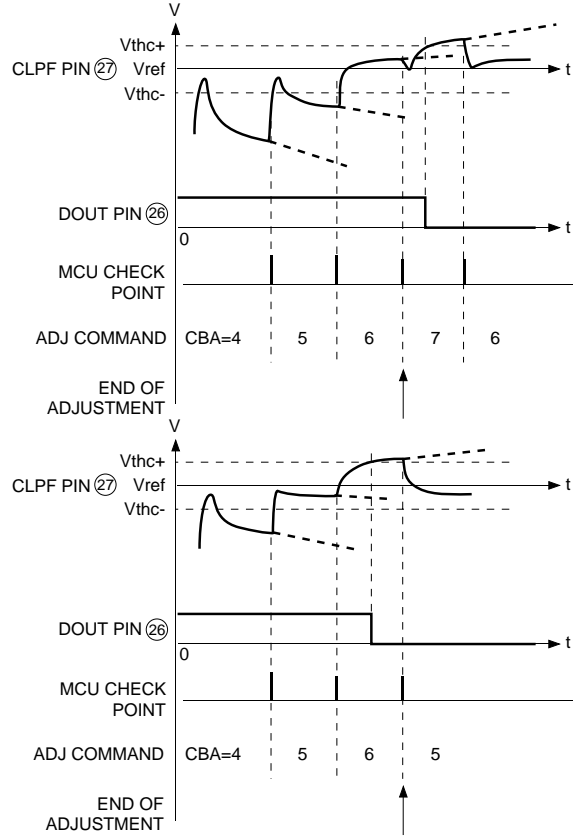



**AUTOMATIC ADJUSTMENT CD PREAMPLIFIER SERVO CONTROLLER**

**SERIAL COMMAND FUNCTION**

An 8-bit shift register is installed in the logic controller to convert (decode) serial data (MSD pin ②<sup>5</sup>) from the microcomputer into a command for the servo IC.

**FUNCTION DESCRIPTION of Data-IN**

Of the 8-bit data, high order 4 bits (D7 to D4) is used to select a command mode and low-order 4 bits (D3 to D0) are used to set (instruct) the command status.

Commands in the same mode can be given concurrently with data transferred once. They are held until new data is entered. Therefore, the command status is held if another mode is selected.

**SERIAL COMMAND FUNCTION TABLE**

Command Name	MSD pin ② <sup>5</sup> input								Data out pin output
	Mode selection				Command status setting				
	D7	D6	D5	D4	D3	D2	D1	D0	
SERVO	0	0	Focus	Brake /Shock	Track		Sledge		FSOK/TC
Track balance	0	1	—	—	—	C	B	A	ADJ
Track Gain	1	0	—	—	—	C	B	A	ADJ
Focus Gain	1	1	—	—	—	C	B	A	ADJ

- Note 1. Output from DOUT pins ②<sup>5</sup> is automatically switched by selecting each mode.  
 2. The status in the Servo Mode is set with two bits for each of command Track (D3,D2) and sledge(D1,D0).

**COMMAND FUNCTION TABLE**

Command	Mode	Data	Function
FS ON	Focus	D5	1 ON • APC amplifier ON • Focus search start to servo ON (PS SW="OPEN")
			0 OFF • APC amplifier OFF • Focus servo OFF (FS SW = "CLOSE")
Brake	Track1	D4	1 Jump brake (jump setting) operation Opens/closes TSSW.
Shock			0 Controls SW 'TG SW' for track gain switching.
Track	Track2	D3 D2	
		0 0	TS OFF Track servo OFF
		0 1	JR Reverse jump
		1 0	JF Forward jump
		1 1	TS ON Track servo ON
Sledge	Track2	D3 D2	
		0 0	SS OFF Sledge servo OFF
		0 1	SR Reverse sledge
		1 0	SF Forward sledge
		1 1	SS ON Sledge servo ON

**AUTOMATIC ADJUSTMENT CD PREAMPLIFIER SERVO CONTROLLER**

**SERIAL DATA (MSD) TRANSFER METHOD**

Data is transferred with LSB first and the MLA signal is sent to execute the command.

**SERIAL DATA INPUT TIMING CHART**

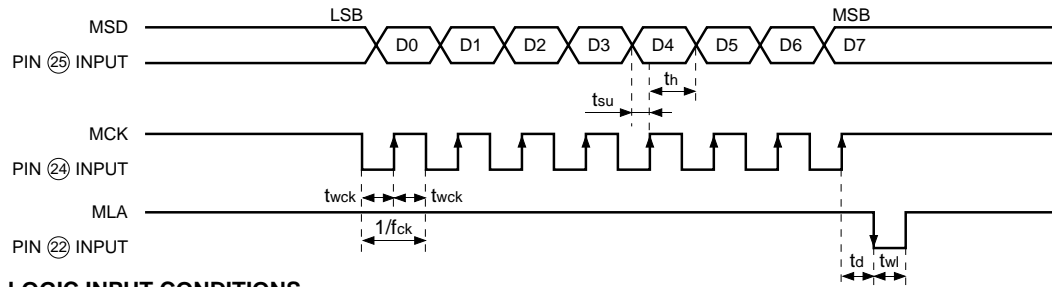

**LOGIC INPUT CONDITIONS**

Symbol	Parameter	Test conditions	Limits			Unit
			Min.	Typ.	Max.	
$f_{ck}$	Clock frequency		—	100	200	kHz
$t_{wck}$	Clock pulse width		2.5	5	—	$\mu s$
$t_{su}$	Setup time		0.1	0.2	—	$\mu s$
$t_h$	Hold time		2.5	5	—	$\mu s$
$t_d$	Delay time		2.5	5	—	$\mu s$
$t_{wl}$	Latch pulse width		1	5	—	$\mu s$

**BRAKE**

Setting the break command to "1" performs the jump brake operation to improve the jump setting capability after the track jump.

Jump Brake Operation

- The track servo loop is set to OFF with TC="↓" (at the falling edge of TCDet output) when MR is 1.
- The track servo loop is set to ON with TC="↓" (at the falling edge of TCDet) when MR is 0.
- Jump Brake True Value List (Effective in the TS ON mode)

INPUT		OUTPUT
MIRROR	TC Det	TS SW status
1 ("Mirror")		OPEN (track servo OFF)
0 ("Track")		CLOSE (track servo ON)

Note 3. TC/SHSW "CLOSE", TG SW "OPEN"

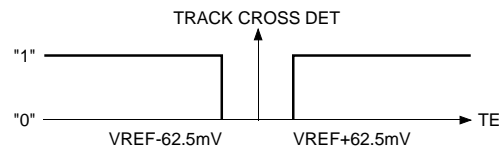

**SHOCK**

With the SHOCK command set to "1", the shock operation is carried out to switch the track gain at time of shock.

Jump Brake Operation

- With SHOCK detect=1, the track gain is placed in the shock mode.
- With SHOCK Det=0, the track gain is placed in the normal mode.
- Shock True Value List (Effective in the TS ON mode)

INPUT		OUTPUT
SHOCK Det		TG SW status
1 ("SHOCK")		OPEN (Shock mode)
0 ("NORMAL")		CLOSE (Normal mode)

Note 4. TC/SH SW "OPEN"  
5.  $V^+$  and  $V^-$  are set with external constant.

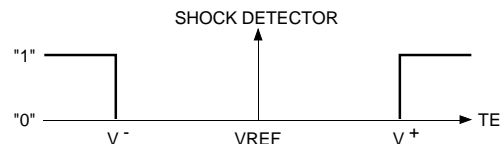

**AUTOMATIC ADJUSTMENT CD PREAMPLIFIER SERVO CONTROLLER**

**TRACK FUNCTION TABLE**

COMMAND	INPUT		OUTPUT (SW Status)		
	D3	D2	TS SW	JF SW	JR SW
TS OFF	0	0	OPEN (Servo OFF)	OFF	OFF
JR	0	1	OPEN (Servo OFF)	OFF	ON
JF	1	0	OPEN (Servo OFF)	ON	OFF
TS ON	1	1	CLOSE (Servo ON)	OFF	OFF

**SLEDGE FUNCTION LIST**

COMMAND	INPUT		OUTPUT (SW status)		
	D1	D0	TS SW	SF SW	JR SW
SS OFF	0	0	CLOSE (Sledge OFF)	OFF	OFF
SR	0	1	CLOSE (Sledge OFF)	OFF	ON
SF	1	0	CLOSE (Sledge OFF)	ON	OFF
SS ON	1	1	OPEN (Sledge ON)	OFF	OFF

**DIRECT COMMAND FUNCTION**

JP1 signal

When a 1-track jump takes place, serial data to be transferred twice can be omitted to control the amount of delay in processing time.

JP1 is generally set to "1". When JP1 is set to "0" with TC (Data out) signal set to "1", the logic controller automatically reverses the jump polarity (JF to JR or JR to JF).

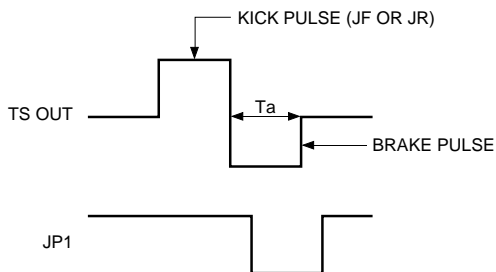

When a jump is complete (after fixed time  $T_a$ ), switching JP1 from "0" to "1" can automatically terminate JF and JR to select the TR ON/SSON status.

Signal Waveform with a jump



**AUTOMATIC ADJUSTMENT CD PREAMPLIFIER SERVO CONTROLLER**

**JP1 SIGNAL TRUE VALUE LIST**

JP1 (INPUT)	TRACK mode							
	TRACK (D3, D2)				SLEDGE (D3, D2)			
	00	11	10	01	00	11	10	01
1	TSOFF	TS ON	JF	JR	SS OFF	SS ON	SF	SR
1 → 0 	TSOFF	TS ON	JR	JF	SS OFF	SS ON	SR	SF
0 → 1 	TSOFF	TS ON	JF	JR	SS OFF	SS ON	SF	SR

**LOGIC OUTPUT FUNCTION**

Data out

Data out output is switched according to the serial command (D6, D7="0", "0") mode (see the serial command function list).

The output corresponding to the serial command mode sent last is given.

**Data Out Output Corresponding List**

	Data out signal name	Serial command mode (input)
(1)	FSOK	FOCUS (0010XXXX)
(2)	TC	TRACK (0001XXXX)

**(1) FS ON**

With FS SW=OPEN (servo ON), FSOK "0" is output.

**(2) TC**



The TC signal that latches the MR signal at the edge (falling edge) of TC Det output is output.

**FSOK TRUE VALUE LIST**

Input	Output
FF SW status	FSOK
CLOSE (Servo OFF)	1
CLOSE (Servo ON)	0

While FS OK is set to "1", TS SW is open (servo OFF) and SS SW is open regardless of the command status.

**TC TRUE VALUE LIST**

Input		Output
MR	TC Det	TC
"1"Mirror		1
"0"Track		0

**MR signal detector**

Detects an envelope of the HF signal and sends data to the internal logic controller.

**AUTOMATIC ADJUSTMENT CD PREAMPLIFIER SERVO CONTROLLER**

**CONTROL METHOD FLOWCHART EXAMPLE**

Note: Since this description applies to an example on the item related to the servo, take into account the entire system when using this. In addition, pay attention to the simplification/reduction of actions in abnormal status.

- ① POWER\_RESET : Processing with power turned on
- ② DISC\_START : Disk start processing
- ③ BALANCE\_ADJ : Track balance processing
- ④ TRACK\_ADJ : Track gain adjustment
- ⑤ FOCUS\_ADJ : Focus gain adjustment
- ⑥ ADJUST : Adjustment routine
- ⑦ SE\_OUT : Adjustment signal output routine
- ⑧ Jump control
- 8-1. SINGLE\_JUMP
- 8-2. SHORT\_JUMP
- 8-3. MID\_JUMP
- 8-4. LONG\_JUMP

**① POWER\_RESET**

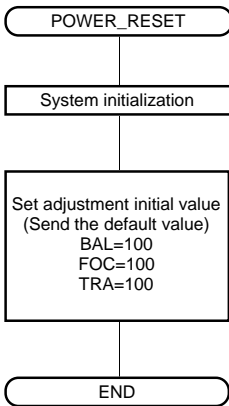

Note: BAL :Track balance  
FOC :Focus gain  
TRA :Track gain

**② DISC\_START**

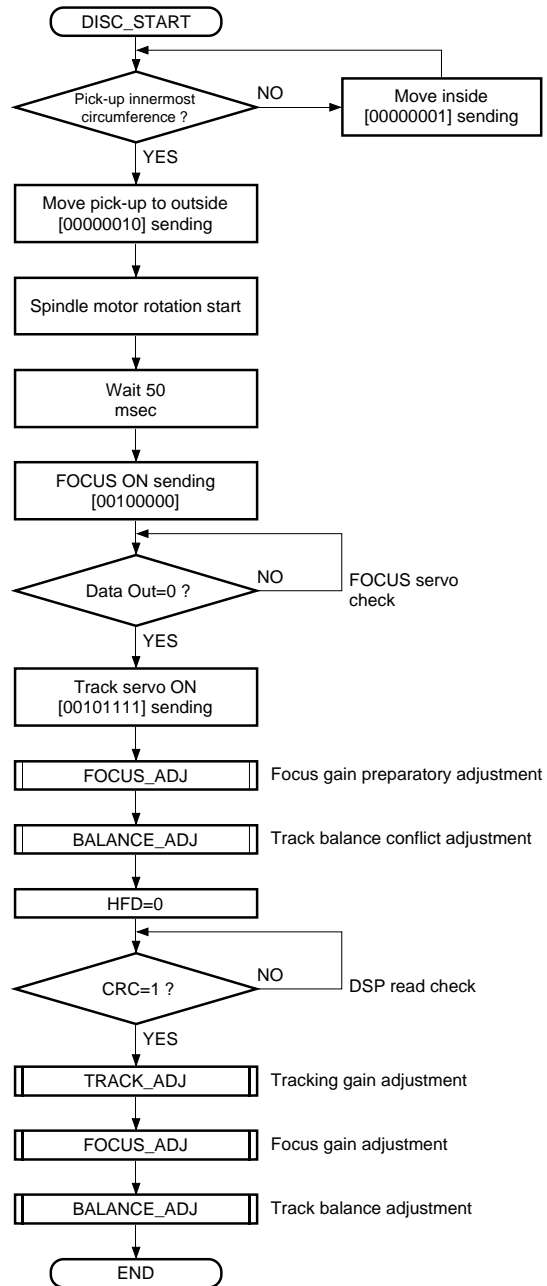

Note: Pick-up servo operation preparatory completion. For example, reading TOC requires to move pick-up to the innermost circumference.

AUTOMATIC ADJUSTMENT CD PREAMPLIFIER SERVO CONTROLLER

③ BALANCE\_ADJ

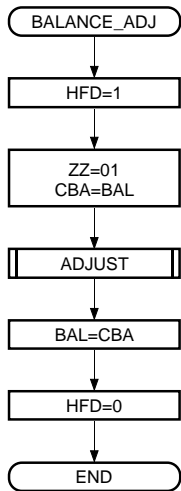

④ TRACK\_ADJ

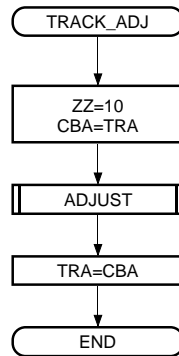

⑤ FOCUS\_ADJ

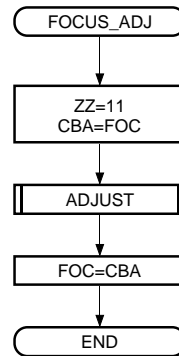

⑥ ADJUST

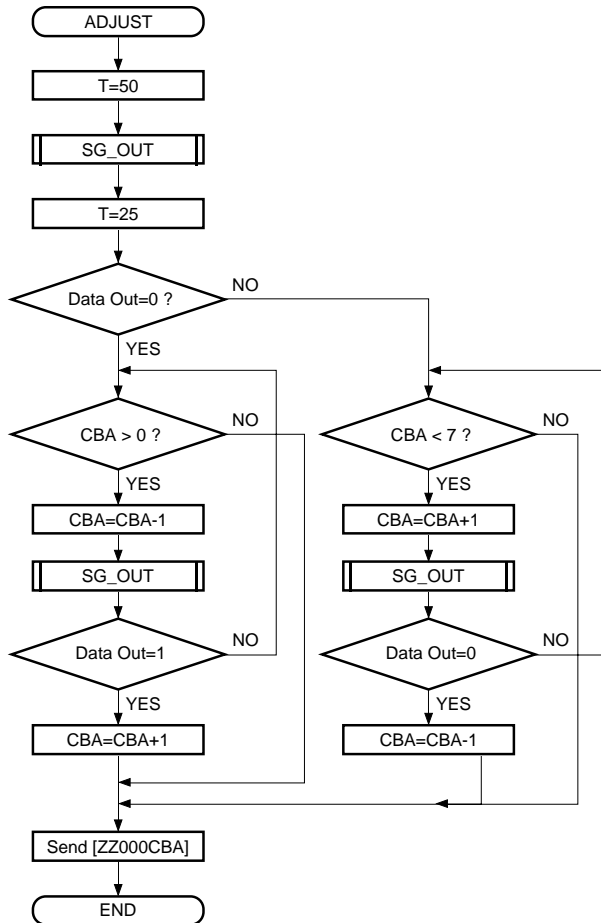

⑦ SG\_OUT

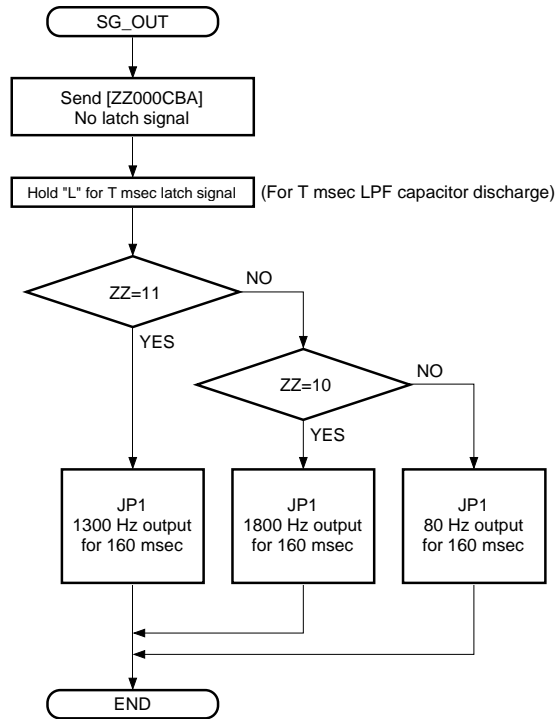

Note: Set the frequency of the adjustment signal according to the system.

**AUTOMATIC ADJUSTMENT CD PREAMPLIFIER SERVO CONTROLLER**

⑧ **Jump control**

The jump control is divided into the following four types according to the track count.

Type	N: Track count (standard)
8-1. SINGLE_JUMP	1 to 5
8-2. SHORT_JUMP	6 to 16
8-3. MID_JUMP	to 100
8-4. LONG_JUMP	to 1000

(Note) Put the check routing of the HFD status in a program. Read the main routine and sub-codes for check, regardless the jump control.

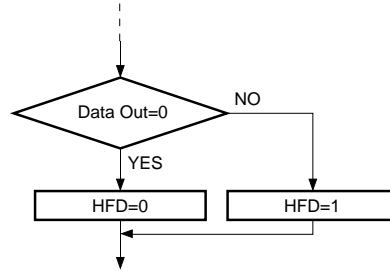

**8-1. SINGLE\_JUMP**

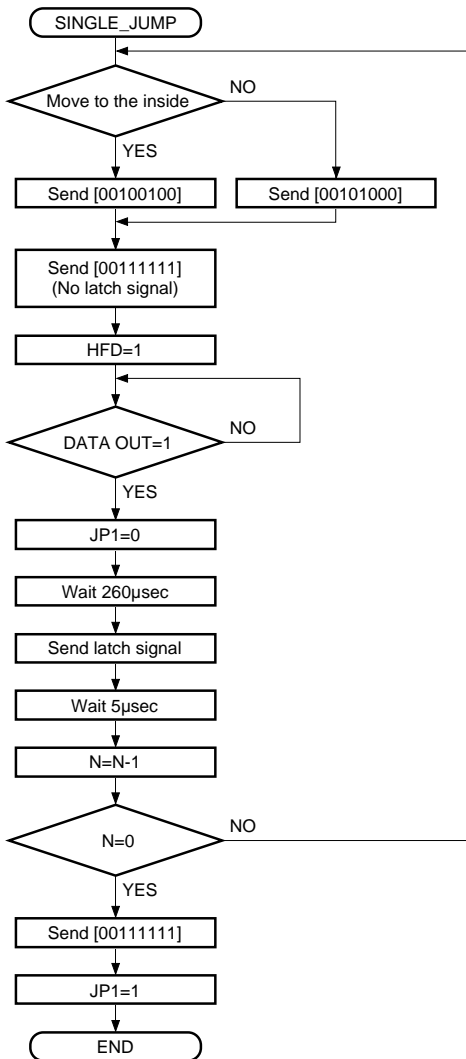

**8-2. SHORT\_JUMP**

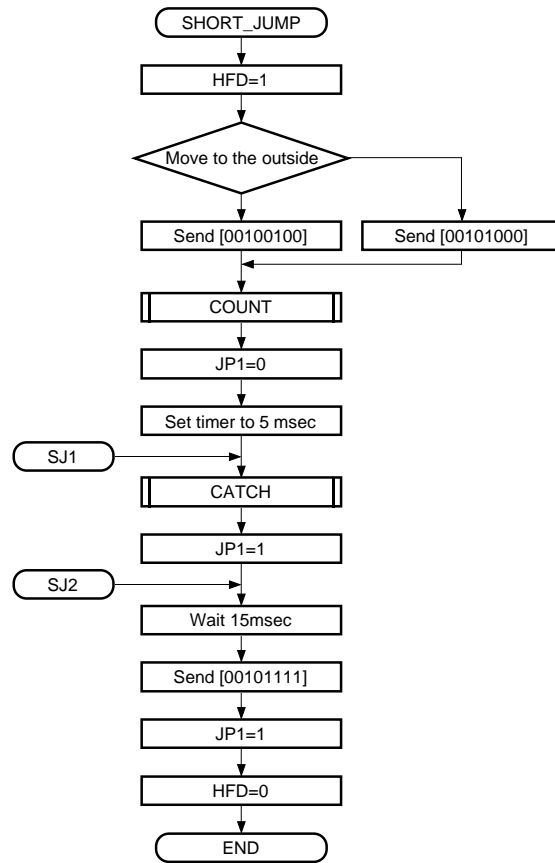

AUTOMATIC ADJUSTMENT CD PREAMPLIFIER SERVO CONTROLLER

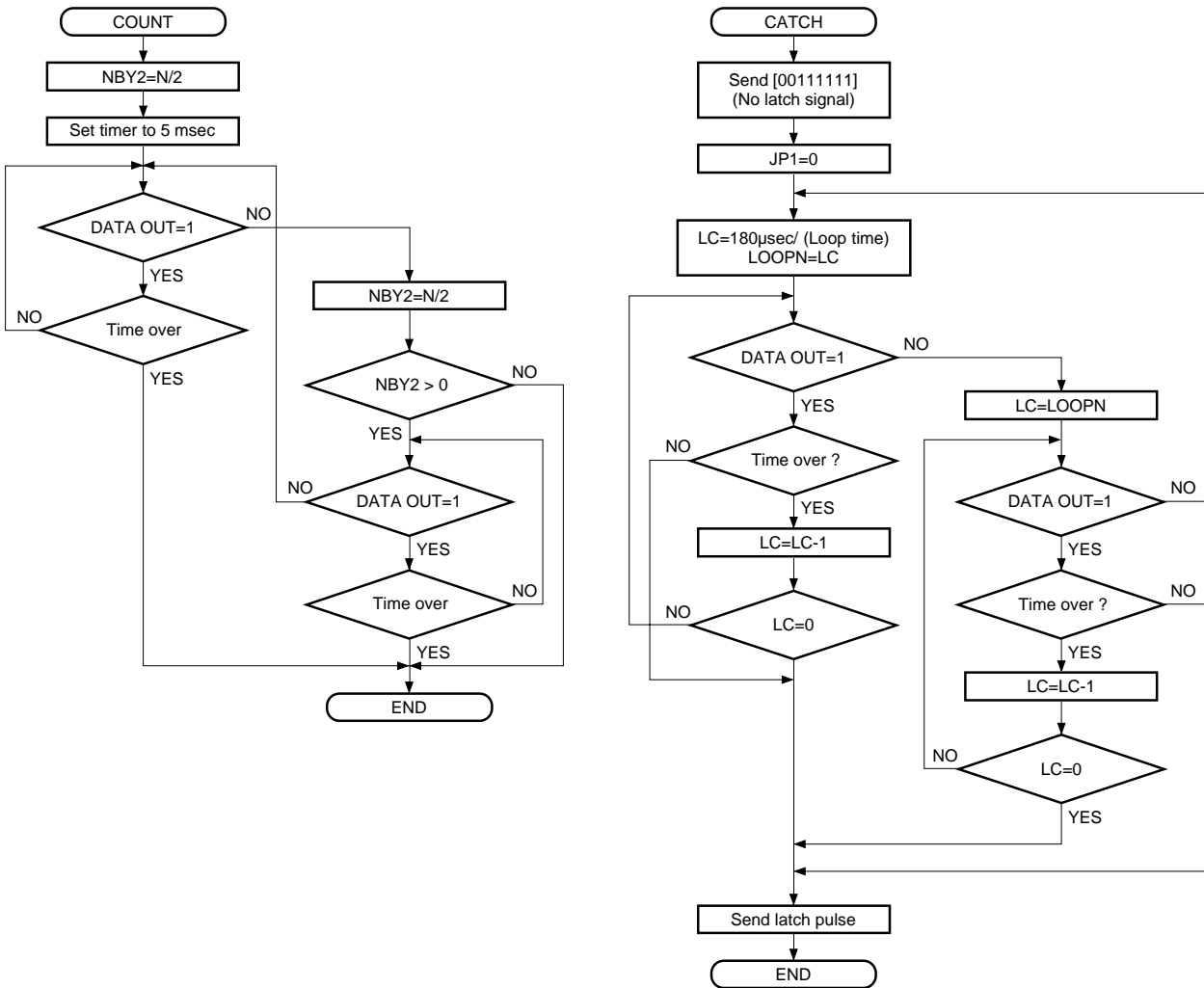



AUTOMATIC ADJUSTMENT CD PREAMPLIFIER SERVO CONTROLLER

8-3. MID\_JUMP

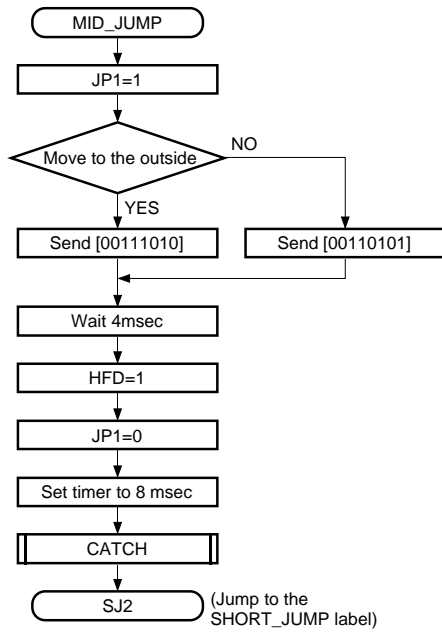

8-4. LONG\_JUMP

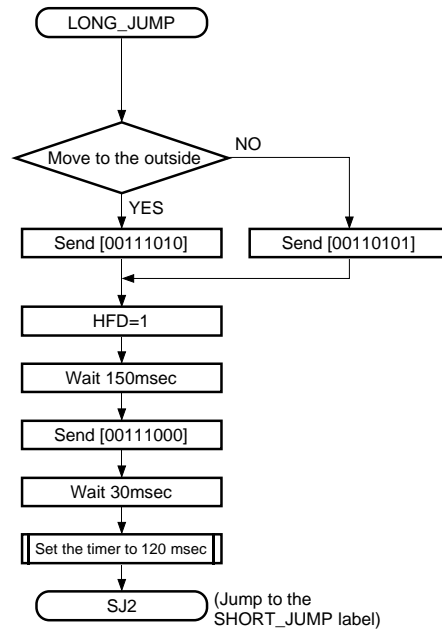

**AUTOMATIC ADJUSTMENT CD PREAMPLIFIER SERVO CONTROLLER**

**TEST CIRCUIT**

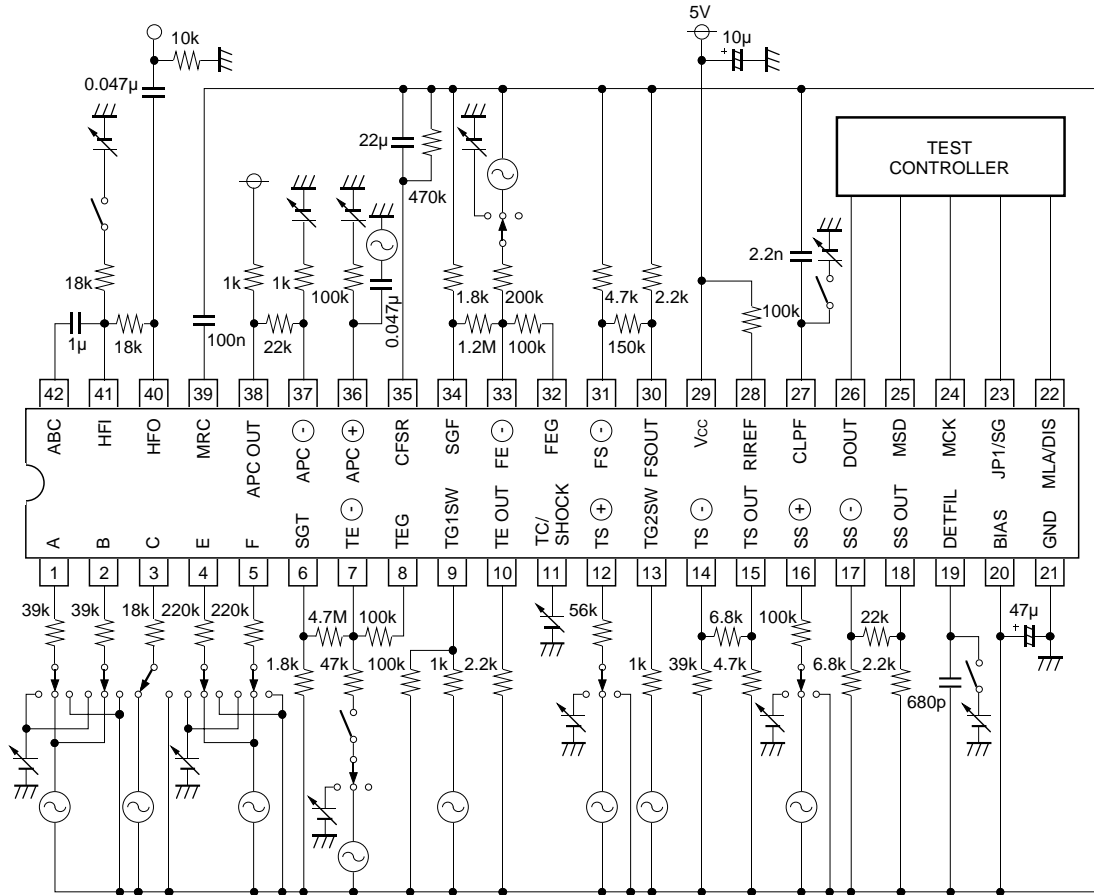

Units Resistance :  $\Omega$   
Capacitance : F

AUTOMATIC ADJUSTMENT CD PREAMPLIFIER SERVO CONTROLLER

TYPICAL CHARACTERISTICS

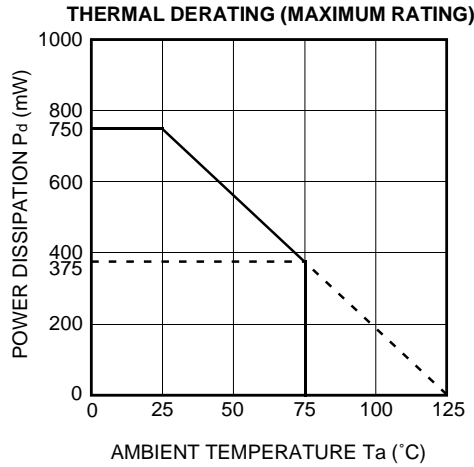

APPLICATION EXAMPLE

